

19



Europäisches Patentamt  
European Patent Office  
Office européen des brevets



11 Publication number : 0 444 621 B1

12

### EUROPEAN PATENT SPECIFICATION

45 Date of publication of patent specification :  
13.09.95 Bulletin 95/37

51 Int. Cl.<sup>6</sup> : G02F 1/136, G02F 1/1345

21 Application number : 91102834.8

22 Date of filing : 26.02.91

54 Liquid crystal display device having a driving circuit.

30 Priority : 27.02.90 JP 18227/90 U  
01.05.90 JP 45085/90 U

43 Date of publication of application :  
04.09.91 Bulletin 91/36

45 Publication of the grant of the patent :  
13.09.95 Bulletin 95/37

84 Designated Contracting States :  
DE FR GB IT NL

56 References cited :  
EP-A- 0 025 250  
FR-A- 2 594 580  
INFORMATION DISPLAY, vol. 5, no. 10,  
October 1989, New York, US, pp. 8-11; B.W.  
FAUGHNAN ET AL.: 'Polysilicon active-matrix  
liquid-crystal displays'

73 Proprietor : CASIO COMPUTER COMPANY  
LIMITED  
6-1, 2-chome, Nishi-Shinjuku  
Shinjuku-ku Tokyo 160 (JP)

72 Inventor : Sawatsubashi, Takeshi, c/o Pat.  
Dep., Dev. Div.  
Casio,  
Computer Co., Ltd.,  
3-2-1, Sakae-cho  
Hamura-machi, Nishitama-gun, Tokyo 190-11  
(JP)

Inventor : Mawatari, Atsushi, c/o Pat. Dep.,  
Dev. Div., Casio  
Computer Co., Ltd.,  
3-2-1, Sakae-cho,  
Hamura-machi

Nishitama-gun, Tokyo 190-11 (JP)

Inventor : Okimoto, Hiroyuki, c/o Pat. Dep.,  
Dev. Div., Casio  
Computer Co., Ltd.,  
3-2-1, Sakae-cho,  
Hamura-machi  
Nishitama-gun, Tokyo 190-11 (JP)

74 Representative : Grünecker, Kinkeldey,  
Stockmalr & Schwanhäusser Anwaltssozietät  
Maximilianstrasse 58  
D-80538 München (DE)

EP 0 444 621 B1

Note : Within nine months from the publication of the mention of the grant of the European patent, any person may give notice to the European Patent Office of opposition to the European patent granted. Notice of opposition shall be filed in a written reasoned statement. It shall not be deemed to have been filed until the opposition fee has been paid (Art. 99(1) European patent convention).

## Description

This invention relates to a liquid crystal display device according to the preamble part of claim 1.

Since the liquid crystal display devices can be made small in size and thin, they are widely used as display devices for word processors, personal computers, television sets and the like.

The liquid crystal display device is used to be connected to separate driving circuits which generate data signals, scanning signals and the like.

From EP-A-025250 a display device is known having a layer of liquid crystal in a space enclosed by a rim of sealing material between two supporting plates. The supply electrodes and connection electrodes are connected to an IC-crystal which is accommodated in a recess in the rim of sealing material of the display device.

From information display Vol. 5, No. 10, 1989, pages 8 to 11, and active matrix liquid crystal display is known using thin film transistors for the matrix element of flat panel displays.

As a material for the thin film transistors hydrogenated amorphous-silicone (a-Si) or poly-crystalline silicone is used which offer the promise of integrating display and drivers on a single substrate.

Recently, in order to meet the requirement in which the display device should be further miniaturized, there has been proposed a liquid crystal display element having a liquid crystal display panel integrally formed with the above-mentioned driving circuit. The structure of the liquid crystal display panel of this type is shown in Figs. 1 and 2.

The panel has two glass substrates 1 and 5. On one glass substrate 1 are formed pixel electrodes 2, thin film transistors 3 connected to the respective pixel electrodes 2, and gate lines  $G_1$  to  $G_m$  and drain lines  $D_1$  to  $D_n$  connected to the transistors 3. An aligning film 4 is formed on the pixel electrodes 2 and the transistors 3. On the other glass substrate 5 is formed a transparent common electrode 6 which is covered with an aligning film 7. Both glass substrates 1 and 5 are arranged to face each other and are fixed by means of a seal member 8. Liquid crystal 9 is filled in the space defined between both glass substrates 1 and 5 through a hole 10. After filling the liquid crystal 9 the hole 10 is sealed by a seal member 11 so that the liquid crystal 9 is kept in the space between the opposed glass substrates 1 and 5. Each pixel is constituted by one of the pixel electrodes 2, the portion of the common electrode 6 which faces the same and the portion of the liquid crystal 9 which is disposed therebetween in such a manner that a plurality of pixels similarly formed are arranged in a matrix form.

A driving circuit comprises drain line driving circuits 12 for supplying data signals to the pixel electrodes 2 and gate line driving circuits 13 for controlling the thin film transistors associated with the respec-

tive pixel electrodes 2 in response to image data to be displayed. Each of the drain line driving circuits 12 and the gate line driving circuits 13 comprises an integrated circuit including a plurality of thin film transistors directly formed on a substrate. The driving circuits 12 and 13 are arranged on the peripheral portions of the glass substrate 1 disposed outside of the seal member 8. The output terminals of the driving circuits 12 and 13 are connected to the drain lines  $D_1$  to  $D_n$  and the gate lines  $G_1$  to  $G_m$ , respectively. The drain line driving circuits 12 and the gate line driving circuits 13 are connected to signal lines 14 which supply control signals and image data signals and are also connected to a terminal 15 provided on the glass substrate 1.

Image data signal and control signals such as clock signals are input to the liquid crystal display device of the active matrix type. The gate signals produced by the gate line driving circuits 13 are supplied to the gate lines  $G_1$  to  $G_m$  in succession and each gate signal selects the corresponding one of the gate lines  $G_1$  to  $G_m$ . The data signals produced by the drain line driving circuits 13 in synchronism therewith at the time interval of the selection of the gate lines are supplied to the drain lines  $D_1$  to  $D_n$ .

The transistors 3, which are connected to one gate line selected by the gate signal, turn on. Each data signal is supplied to the pixel electrode through the turned-on transistors 3. An electric field is produced between the pixel electrode 2 to which the gate signal is supplied and the common electrode 6 to which a common signal is supplied. The liquid crystal 9 disposed between both electrodes 2 and 6 is made active by means of the electric field so as to display image data.

Since the driving circuit is integrally formed with the liquid crystal display panel in the liquid crystal display device as explained above, the display device is made small in size. No process is required to connect the driving circuit to the panel by means of lead wires or the like, leading to the simplified manufacturing process.

However, the above-mentioned driving circuit is mounted on the portions of the liquid crystal panel which is disposed outside of the seal member 8. Thus, the outer peripheral portions of the substrate 1 require a large area. In other words, the liquid crystal display panel has a large peripheral area which is not associated with the image display and this peripheral area surround the display area in which the pixels are arranged in a matrix form and which is effective for image display. Accordingly, this liquid crystal display device has a problem that it requires a large area.

The object of this invention is to provide a small sized liquid crystal display device which overcomes the problem as mentioned above.

This object is attained by a liquid crystal display device comprising the features of patent claim 1.

Since at least a portion of the driving circuit for supplying driving signals to the drain lines and the gate lines is provided between the inner edges of the seal member and the outer edges of the display region, the gate lines and the drain lines can be shortened so that the resistances of the lines are lowered and the potential drops of the gate lines and the drain lines are reduced. Accordingly, the display can be made evenly throughout the display region.

This invention can be more fully understood from the following detailed description when taken in conjunction with the accompanying drawings, in which:

Fig. 1 is a general plan view illustrating the structure of a conventional liquid crystal display device having a driving circuit;

Fig. 2 is a cross-sectional view along line II-II of Fig. 1;

Fig. 3 is a general plan view illustrating the structure of a liquid crystal display element according to an embodiment of this invention;

Fig. 4 is a cross-sectional view along line IV-IV of Fig. 3;

Fig. 5 is a block diagram of a driving circuit for the liquid crystal display device of Fig. 3;

Fig. 6 is an enlarged plan view of a pixel portion of the liquid crystal display device of Fig. 3 when TFTs are used as active elements;

Fig. 7 is a cross-section view along line VII-VII of Fig. 6;

Fig. 8 is a general plan view of a liquid crystal display device according to another embodiment of this invention;

Fig. 9 is an enlarged plan view of a pixel portion of Fig. 8 when TFTs are used as active elements;

Fig. 10 is a cross-sectional view of one of the TFTs as shown in Fig. 9; and

Fig. 11 is a cross-sectional view of a main part of a liquid crystal display device of a further embodiment of this invention.

This invention will be explained by way of preferred embodiments with reference to the accompanying drawings.

In Figs. 3 and 4 are provided a pair of transparent substrates 101 and 102 made of glass, quartz or the like. On one surface of the substrate 101 (the lower substrate in Fig. 4) are arranged a plurality of pixel electrodes 103 for display and thin film transistors for pixels (hereinafter referred to as "TFTs"), each of which is connected to the respective pixel electrode 103 and selectively drives the same so that the electrodes 103 and the TFTs 104 are arranged in a matrix form. As shown in Figs. 6 and 7, the TFT 104 comprises a gate electrode 104a, a gate insulating film 104b, a semiconductor film 104c made of amorphous silicon or polysilicon, a source electrode 104d and a drain electrode 104e so that they are laminated and a channel portion is formed in the upper surface of the resultant lamination. Each of the source electrode

104d and the drain electrode 104e comprises an n<sup>+</sup> semiconductor film 104f and a contact metal film 104g. The pixel electrode 103 is connected to the source electrode 104d of the TFT 104. A plurality of gate lines G<sub>1</sub> to G<sub>m</sub> and a plurality of data lines D<sub>1</sub> are formed on the surface of the substrate 101 so as to intersect at right angles with each other. The gate lines G<sub>1</sub> to G<sub>n</sub> are connected to the gate electrodes 104a of the respective TFTs 104, and the data lines D<sub>1</sub> are connected to the drain electrodes 104e of the respective TFTs 104. An aligning film 106 is formed on the TFTs 104.

On one surface of the other substrate 102 (the upper substrate in Fig. 4) is formed an opposed electrode 105. This opposed electrode 105 is integrally formed to oppose all of the pixel electrodes 103 or is formed into a plurality of divided sections to oppose the pixel electrodes 103 arranged in at least one low direction. Aligning films 107 are formed on the surfaces of the substrates 102 on which the opposed electrodes 105 are formed. The paired substrates 101 and 102 are firmly connected together by means of a seal member 108 having a hole 108a so that the surfaces of both substrates 101 and 102 on which the electrodes are formed face each other. Liquid crystal 109 is filled through the hole 108a in a space defined between the substrates 101 and 102 and is sealed by a seal member 110.

In such a way, a pixel is formed by a pixel electrode 103, the portion of the electrode 105 which faces the pixel electrode 103 and the portion of the liquid crystal 109 disposed between the electrodes 103 and 105. A plurality of the pixels having the same structure are arranged in a matrix form to form a display region 111 for displaying a required image.

A driving circuit is provided between the outer edges of the display region defined between the substrates 101 and 102 and the outer edges of the seal member 108. In this arrangement, the driving circuit is provided with drain line driving circuits 112 for supplying data signals to the pixel electrodes 103 and gate line driving circuits 113 for controlling the TFTs 104, each of which is provided for the respective pixel electrode 103.

Each of the drain line driving circuits 112 and the gate line driving circuit 113 comprises an integrated circuit which has a plurality of thin film transistors made of amorphous silicon or a polysilicon semiconductor material. Each of the drain line driving circuit 112 and the gate line driving circuit 113 has an outer edge overlapped with the seal member 108 and has an inner edge extending in the region in which the liquid crystal 109 is sealed.

In the drain lines D<sub>1</sub> to D<sub>n</sub>, the odd numbered drain lines are connected to the upper drain line driving circuit 112 provided above the substrate 101, and the even numbered drain lines are connected to the lower drain line driving circuit 112 on the substrate

101. In the gate lines  $G_1$  to  $G_m$ , the odd numbered gate lines are connected to the gate line driving circuit 113 disposed at the left side portion of the substrate 101, and the even numbered gate lines are connected to the gate line driving circuit 113 disposed at the right side portion of the substrate 101. The drain line driving circuits 112 and the gate line driving circuits 113 are connected together by means of signal lines 114 for supplying control signals, data signals and the like. The signal lines 114 are connected to a terminal 115 through which the control signals, the image data signals and the like are supplied to the driving circuits 112 and 113 from the signal supplying device provided outside of the display device.

As shown in Fig. 5, the drain line driving circuit 112 comprises a data latch circuit 112a having shift registers or the like for memorizing, in turn, every other image data signals supplied from the signal lines 114, and a data signal generating circuit 112b connected to the data latch circuit 112a, for outputting a required voltage signal to the corresponding data line in response to a supplied clock signal when a latched data signal is output. The gate line driving circuit 113 comprises a circulating memory circuit 113a for circulating a data in the shift registers in response to the supplied clock signal, and a gate signal generating circuit 113b for generating gate signals for selecting every other gate lines in response to the outputs from the circulating memory circuit 113a.

In the liquid crystal display device of an active matrix type according to this invention, image data signal, clock signals and the like are transmitted from the terminal 115 to the drain line driving circuits 121 and the gate line driving circuits 113 through the signal lines 114. The gate line driving circuits 113 provided at both sides of the substrate 101 alternately generate gate signals and supply them to the gate lines  $G_1$  to  $G_m$  so that one of the gate lines is selected in response to the corresponding one of the gate signals. At the time interval of the selection of the gate line, the transistors 104 connected to the selected gate line are turned on. A data signal produced in synchronism with the gate signals by the drain line driving circuits 112 is supplied to the drain lines  $D_1$  to  $D_n$ , with the result that the data signal supplied to the drain line is supplied to the pixel electrode 103. As a common signal is applied to the opposed electrode 105, an electric field is produced between the opposed electrode 105 and acts on the portion of the liquid crystal 109 between both electrodes 103 and 105 so that this portion of the liquid crystal displays image data is displayed.

In the above mentioned embodiment, the drain line driving circuits 112 and the gate line driving circuit 113 are disposed in portions defined between the outer edges of the seal member 108 and the outer edges of the display region 111 between the substrates 101 and 102.

When the substrates 101, 102 are connected to each other through the seal member 108 in the conventional device, stress is concentrated on a portion near to the seal member 108 of the substrates 101, 102 so that a strain is produced at the portion. Therefore, the gap between the opposed substrates 101, 102 becomes un-uniform, and a portion near to the seal member 108 and located inside of the seal member 108 becomes a blank region.

The liquid crystal display device according to this invention uses this unusable region very effectively in comparison with the conventional device. A driving circuit assembly (hereinafter referred to as only the "driving circuit") comprising the drain line driving circuits 112 and the gate line driving circuits 113 is provided on the conventionally unusable portion of the substrate 101. In this connection, it is necessary to provide any driving circuits on the outside region of the seal member. This structure renders the outer dimension of the substrate 101 small, resulting in the miniaturizing of the liquid crystal display device.

Further, the drain line driving circuits 112 and the gate line driving circuit 113 are disposed within the region defined within inner edges of seal member 108. This structure shortens the length of the gate lines  $G_1$  to  $G_m$  and the drain lines  $D_1$  to  $D_n$  so as to reduce the wiring resistances and thus lower the potential drops of the gate lines  $G_1$  to  $G_m$ . This enables the display device to exhibit a uniform display over the whole display region.

Fig. 8 shows a second embodiment according to this invention in which the same members as those of the embodiment of Fig. 3 are designated by the same referential numerals, the description thereof being omitted. In the second embodiment, a driving circuit comprising a drain line driving circuit 112 and a gate line driving circuit 113 are provided between the outer edges of a display region 111 of a substrate 101 and the inner edges of a seal member 108. In other words, the driving circuit is disposed outside of the display region 101 and at the region where the driving circuit does not overlap with the seal member 108. Since the seal member 108 is directly fixed to the substrate 101 and a substrate 102, the adhesive force is rendered large, thereby firmly connecting both substrates together. No stresses are applied to the driving circuit when both substrates are connected together by means of the seal member 108 so that no defects appear in the driving circuit due to the stresses, leading to an improved quality of the liquid crystal display device.

In both embodiments, an active element provided for each pixel and a driving circuit for driving each pixel are thin film transistors each using a polysilicon semiconductor film. Alternatively, it is preferred that the active element be a thin film transistor using amorphous silicon semiconductor films and the driving circuit be an integrated circuit made up of a thin

film transistors using polysilicon semiconductor films.

The active element of the liquid crystal display device is not limited to a TFT but may be a non-linear resistance element such as a diode using a thin film semiconductor (hereinafter referred to as the "TFD"). The structure of a liquid crystal device using a TFD is shown in Figs. 9 and 10.

In Fig. 9, a plurality of pixel electrodes 117 are arranged on a substrate 116 in a matrix form. Between the pixel electrodes 117 arranged in column are provided data lines D extending along the corresponding columns. The pixel electrodes 117 and the data lined D are forwardly connected in series by means of a group of forward biased diodes 120 and reversely connected in series by means of a group of diodes 121 comprising a plurality of reversely biased diodes 119 so as to form so-called diode rings.

As shown in Fig. 10, each diode 119 has formed on the substrate 119 an electrically conducting film 119a which comprises a contact metal film 119b, a P-type semiconductor 119c, an I-type semiconductor film 119d, an N-type semiconductor film 119e and a contact metal film 119f superposed on one after another in turn on the electrically conducting film 119a. On the thin film diode 119 is formed an electrically insulating film 122 having a through hole 122a through which an electrically connecting conductor 123 is electrically connected to the contact metal 119f.

The group of the forwardly biased diodes 120 are formed on the extensions from the drain lines D and the electrically conducting films 119a formed separately from each other. Each electrically connecting conductor 123 connects the upper contact metal 119f of the corresponding diode 119 to the electrically conducting film 119a of the adjacent diode 119 and the corresponding pixel electrode 117 to the diode 119 of the corresponding last stage.

The group of reversely biased diodes 121 are formed on parts of pixel electrodes 117 and electrically conducting films 119a formed separately from each other. Each electrically connecting conductor 123 connects the upper contact metal 119f of the corresponding diode 119 to the electrically conducting film 119a of the adjacent diode 119 and the diode 119 of the corresponding last stage to the corresponding drain line D.

In the liquid crystal optical element using the TFDs, voltages are selectively impressed between the pixel electrode 117 and an opposed electrodes 118 which are arranged on an another substrate (not shown) facing the same so as to intersect with the drain lines D at right angles in such a manner that the transmittance of each pixel is controlled so that a required image is displayed.

Needless to say, the liquid crystal display device is not limited to the device of the active matrix type but may be a liquid crystal display device of a simple

matrix type having a pair of opposing substrates formed with electrodes intersecting with each other at right angles. In this case likewise in the case of the above embodiments, the driving circuit for supplying voltages to the electrodes is disposed between the outer edges of the seal member and outer edges of the display region in which pixels comprising intersecting electrodes and liquid crystal interposed between the electrodes are formed in a matrix form.

In the above-mentioned embodiments, the driving circuit is distributed to the four side edge portions of the electrodes, and every other lines of the data lines and the drain lines are driven. However, a single data line driving circuit may be formed on either the upper (in the drawings) edge portion or the lower (in the drawings) edge portion of the substrates, and a single gate line driving circuit may be formed on either the left edge portion or the right edge portion of the substrates so that the data lines and the gate lines are driven by the single data line driving circuit and the single gate line driving line circuit respectively.

Fig. 11 shows a third embodiment according to this invention, in which means for preventing light from being emitted on the driving circuit is provided so that the thin film transistors do not function erroneously. The structure of the third embodiment will now be described. The same parts of the third embodiment as those of the other embodiments are denoted by the same referential numerals, the description thereof being omitted.

As shown in Fig. 11, the liquid crystal display element has a lower substrate 101 having formed thereon a driving circuit including gate line driving circuits 113 and drain line driving circuits 112, and an upper substrate 102 opposing the substrate 101. The liquid crystal display device is further provided with a shading film 124 made of metal such as chromium. The shading film 124 is formed on that portion of the upper substrate 102 on which the driving circuit on the lower substrate 101 faces, and has such an area as is larger than those of the gate line driving circuit 113 and the drain line driving circuit 112 but does not overlaps the display region of the liquid crystal display element. Accordingly, the shading film 124 prevents light beams from being emitted on the driving circuit so that the driving circuit does not function erroneously due to light beams.

In the third embodiment, the driving circuit is disposed such that its outer edges are disposed within the portions of the width of the seal member 108 and its inner edges are positioned between the inner edges of the seal member 108 and the extreme outer edge portions of the liquid crystal sealed region. However, the overall driving circuit may be disposed on such the outer peripheral portions of the liquid crystal sealed portion as are not used as part of the display region.

## Claims

1. A liquid crystal display device, comprising: a first substrate on which at least one first electrode (105, 118) is formed; a second substrate (101, 116) supporting a plurality of second electrodes (103, 117), signal supplying leads ( $D_1$  to  $D_n$ ,  $G_1$  to  $G_m$ ) for supplying driving signals to said second electrodes, and a driving circuit (112, 113) for generating a driving signal on the basis of external input display data and selectively supplying said driving signal to one of said signal supplying leads; said first and second substrates being connected to each other at their peripheral portions by a seal member (108) with a predetermined gap therebetween so that said second electrodes oppose said first electrode, and a liquid crystal material (109) being sealed in the space surrounded by said first and second substrates and said seal member, a plurality of pixels which define a display region (111), whereby each of said pixels is formed by one of said plurality of second electrodes (103, 117), a portion of the first electrode (105, 118) which faces said second electrode and a portion of the liquid crystal material (109) which is interposed between these electrodes, characterized in that at least a part of said driving circuit (112, 113) is provided between the inner edges of said seal member (108) and the outer edges of said display region (111) whereby contacting said liquid crystal material (109).
2. A liquid crystal display device according to claim 1, characterized in that at least part of said driving circuit (112, 113) overlaps with said seal member (108).
3. A liquid crystal display device according to claims 1 or 2, characterized by further comprising active elements (104, 119) each using a thin film semiconductor mounted on said second substrate (101, 116) and electrically connected to a corresponding one of said second electrodes (103, 117) and said signal supplying leads ( $D_1$  to  $D_n$ ,  $G_1$  to  $G_m$ ) at a portion corresponding to said one of said second electrodes.
4. A liquid crystal display device according to claim 3, characterized in that each of said active elements (104, 119) is a thin film transistor made from thin films laminated on said second substrate (101, 116).
5. A liquid crystal display device according to claim 3, characterized in that each of said active ele-

ments (104, 119) is a non-linear resistance element having thin films laminated on said second substrate (101, 116).

6. A liquid crystal display device according to claim 5, characterized in that said non-linear element is a thin film diode (119).
7. A liquid crystal display device according to claim 4, characterized in that the thin film transistor (104, 119) uses thin amorphous silicon films formed by laminating thin films on said second substrate (101, 116) as semiconductor films, and said driving circuit (112, 113) is an integrated circuit constructed by a plurality of thin film transistors formed on said second substrate (101, 116) and using thin polysilicon films as semiconductor films.
8. A liquid crystal display device according to claim 4, characterized in that the thin film transistor (104, 119) uses thin polysilicon films formed by laminating thin films on said second substrate (101, 116) as semiconductor films, and said driving circuit (112, 113) is an integrated circuit constructed by a plurality of thin film transistors formed on said second substrate (101, 116) using thin polysilicon films as semiconductor films.
9. A liquid crystal display device according to claim 4, characterized by further comprising a shielding film (124) formed of light shielding material on a surface of said second substrate (101, 116) which faces said first substrate (102), for shielding light emitted on said driving circuit (112, 113).

## Patentansprüche

1. Flüssigkeitskristallanzeigegerät, umfassend: ein erstes Substrat, auf dem wenigstens eine erste Elektrode (105, 118) ausgebildet ist, ein zweites Substrat (101, 116) zum Haltern einer Vielzahl von zweiten Elektroden (103, 117), Signalversorgungsleitungen ( $D_1$  bis  $D_n$ ,  $G_1$  bis  $G_m$ ) zum Anlegen von Treibersignalen an die zweiten Elektroden, und einer Treiberschaltung (112, 113) zum Erzeugen eines Treibersignals auf der Grundlage von extern eingegebenen Anzeigedaten und zum selektiven Anlegen des Treibersignals an eine der Signalversorgungsleitungen; wobei das erste und zweite Substrat miteinander an ihren Randbereichen mittels einer Dichtung (108) verbunden sind, mit einem vorgegebenen Spalt zwischen ihnen, so daß die zweiten Elektrode der ersten Elektrode gegenüberliegen und ein Flüssigkeitskristallmaterial (109) in dem Raum

dichtend eingebracht ist, der von dem ersten und zweiten Substrat sowie der Dichtung umgeben wird,

eine Vielzahl von Pixeln, die einen Anzeigebereich (111) definieren, wobei jeder der Pixel von einer der Vielzahl von zweiten Elektroden (103, 117), einem Teil der ersten Elektroden (105, 118), welche den zweiten Elektroden gegenüberliegt und einem Bereich des Flüssigkeitskristallmaterials (109) gebildet ist, welches zwischen diesen Elektroden angeordnet ist,

dadurch gekennzeichnet, daß wenigstens ein Teil der Treiberschaltung (112, 113) zwischen den inneren Kanten der Dichtung (108) und den äußeren Kanten des Anzeigebereichs (111) angeordnet ist, wodurch das Flüssigkeitskristallmaterial (109) kontaktiert wird.

2. Flüssigkeitskristallanzeigegerät nach Anspruch 1, dadurch gekennzeichnet, daß wenigstens ein Teil der Treiberschaltung (112, 113) die Dichtung (108) überlappt.

3. Flüssigkeitskristallanzeigegerät nach Anspruch 1 oder 2, dadurch gekennzeichnet, daß das Gerät weiterhin aktive Elemente (104, 119) umfaßt, von denen jedes ein Dünnschicht-Halbleiterelement verwendet, das auf dem zweiten Substrat (101, 116) montiert ist und elektrisch mit einer entsprechenden der zweiten Elektroden (103, 117) und den Signalversorgungsleitungen ( $D_1$  bis  $D_n$ ,  $G_1$  bis  $G_m$ ) verbunden ist, an einem Bereich, der der einen der zweiten Elektroden entspricht.

4. Flüssigkeitskristallanzeigegerät nach Anspruch 3, dadurch gekennzeichnet, daß jedes der aktiven Elemente (104, 119) ein Dünnschichttransistor ist, der aus dünnen Filmschichten hergestellt ist, welche auf dem zweiten Substrat (101, 116) laminiert sind.

5. Flüssigkeitskristallanzeigegerät nach Anspruch 3, dadurch gekennzeichnet, daß jedes der aktiven Elemente (104, 119) ein nicht-lineares Widerstandselement ist, das dünne Filmschichten besitzt, welche auf dem zweiten Substrat (101, 116) laminiert sind.

6. Flüssigkeitskristallanzeigegerät nach Anspruch 5, dadurch gekennzeichnet, daß das nicht-lineare Element eine Dünnschichtdiode (119) ist.

7. Flüssigkeitskristallanzeigegerät nach Anspruch 4, dadurch gekennzeichnet, daß der Dünnschichttransistor (104, 119) dünne amorphe Siliziumfilmschichten verwendet, welche durch La-

minieren von dünnen Filmschichten auf dem zweiten Substrat (101, 116) als Halbleiterfilmschichten gebildet sind, und

daß die Treiberschaltung (112, 113) eine integrierte Schaltung ist, die aus einer Vielzahl von Dünnschichttransistoren aufgebaut ist, welche auf dem zweiten Substrat (101, 116) gebildet sind und unter Verwendung von dünnen Polysiliziumfilmschichten als Halbleiterfilmschichten.

8. Flüssigkeitskristallanzeigegerät nach Anspruch 4, dadurch gekennzeichnet, daß der Dünnschichttransistor (104, 119) dünne Polysiliziumfilmschichten verwendet, die durch Laminiere von Dünnschichten auf dem zweiten Substrat (101, 116) als Halbleiterfilmschichten gebildet werden, und daß die Treiberschaltung (112, 113) eine integrierte Schaltung ist, die aus einer Vielzahl von Dünnschichttransistoren aufgebaut ist, welche auf dem zweiten Substrat (101, 116) ausgebildet sind unter Verwendung der dünnen Polysiliziumfilmschichten als Halbleiterfilmschichten.

9. Flüssigkeitskristallanzeigegerät nach Anspruch 4, dadurch gekennzeichnet, daß es weiterhin eine Abschirmfilmschicht (124) umfaßt, die aus einem lichtabschirmenden Material auf einer Oberfläche des zweiten Substrats (101, 116) ausgebildet ist, welches dem ersten Substrat (102) gegenüberliegt zum Abschirmen von Licht, welches auf die Treiberschaltung (112, 113) fällt.

## Revendications

1. Dispositif d'affichage à cristaux liquides comprenant : un premier substrat sur lequel est formée au moins une première électrode (105, 118) ;

un second substrat (101, 116) supportant plusieurs secondes électrodes (103, 117), des conducteurs de délivrance de signaux ( $D_1$  à  $D_n$ ,  $G_1$  à  $G_m$ ) pour délivrer des signaux d'attaque aux dites secondes électrodes, et un circuit d'attaque (112, 113) pour produire un signal d'attaque sur la base de données d'affichage entrées de l'extérieur et pour délivrer de manière sélective ledit signal d'attaque à l'un desdits conducteurs de délivrance de signaux ;

lesdits premier et second substrats étant reliés l'un à l'autre au droit de leurs parties périphériques par un élément d'étanchéité (108), avec un écartement prédéterminé entre eux, de telle manière que lesdites secondes électrodes soient en face de ladite première électrode, et une matière à base de cristaux liquides (109) étant enfermée dans l'espace entouré par lesdits premier et second substrats et ledit élément

d'étanchéité ;

plusieurs pixels qui définissent une région d'affichage (111), chacun desdits pixels étant formé par l'une desdites plusieurs secondes électrodes (103, 117), une partie de la première électrode (105, 118) qui fait face à ladite seconde électrode et une partie de la matière à base de cristaux liquides (109) qui est interposée entre ces électrodes ;

caractérisé en ce que :

au moins d'une partie dudit circuit d'attaque (112, 113) est située entre les bords intérieurs dudit élément d'étanchéité (108) et les bords extérieurs de ladite région d'affichage (111) en contactant ainsi ladite matière à base de cristaux liquides (109).

2. Dispositif d'affichage à cristaux liquides selon la revendication 1, caractérisé en ce qu'au moins une partie dudit circuit d'attaque (112, 113) est à recouvrement partiel avec ledit élément d'étanchéité (108). 20
3. Dispositif d'affichage à cristaux liquides selon la revendication 1 ou 2, caractérisé en ce qu'il comprend en outre des éléments actifs (104, 119) utilisant chacun un semi-conducteur à couches minces monté sur ledit second substrat (101, 116) et connecté électriquement à l'une desdites secondes électrodes (103, 117) qui lui correspond et auxdits conducteurs de délivrance de signaux ( $D_1$  à  $D_n$ ,  $G_1$  à  $G_m$ ) au droit d'une partie correspondant à ladite une desdites secondes électrodes. 25 30 35
4. Dispositif d'affichage à cristaux liquides selon la revendication 3, caractérisé en ce que chacun desdits éléments actifs (104, 119) est un transistor à couches minces fait de couches minces stratifiées sur ledit second substrat (101, 116). 40
5. Dispositif d'affichage à cristaux liquides selon la revendication 3, caractérisé en ce que chacun desdits éléments actifs (104, 119) est un élément à résistance non linéaire comportant des couches minces stratifiées sur ledit second substrat (101, 116). 45
6. Dispositif d'affichage à cristaux liquides selon la revendication 5, caractérisé en ce que ledit élément non linéaire est une diode à couches minces (119). 50
7. Dispositif d'affichage à cristaux liquides selon la revendication 4, caractérisé en ce que le transistor à couches minces (104, 119) utilise, comme couches semi-conductrices, des couches minces de silicium amorphe formées par stratification de 55

couches minces sur ledit second substrat (101, 116) ; et

en ce que ledit circuit d'attaque (112, 113) est un circuit intégré constitué par plusieurs transistors à couches minces formés sur ledit second substrat (101, 116) et utilisant, comme couches semi-conductrices, des couches minces de silicium polycristallin.

8. Dispositif d'affichage à cristaux liquides selon la revendication 4, caractérisé en ce que le transistor à couches minces (104, 119) utilise, comme couches semi-conductrices, des couches minces de silicium polycristallin formées par stratification de couches minces sur ledit second substrat (101, 116) ; et 10 15

en ce que ledit circuit d'attaque (112, 113) est un circuit intégré constitué par plusieurs transistors à couches minces formés sur ledit second substrat (101, 116) et utilisant, comme couches semi-conductrices, des couches minces de silicium polycristallin.

9. Dispositif d'affichage à cristaux liquides selon la revendication 4, caractérisé en ce qu'il comprend en outre un film de protection (124) formé d'une matière faisant écran à la lumière sur une face dudit second substrat (101, 116) qui fait face audit premier substrat (102), pour faire écran à la lumière émise vers ledit circuit d'attaque (112, 113). 20 25 30 35 40 45 50 55

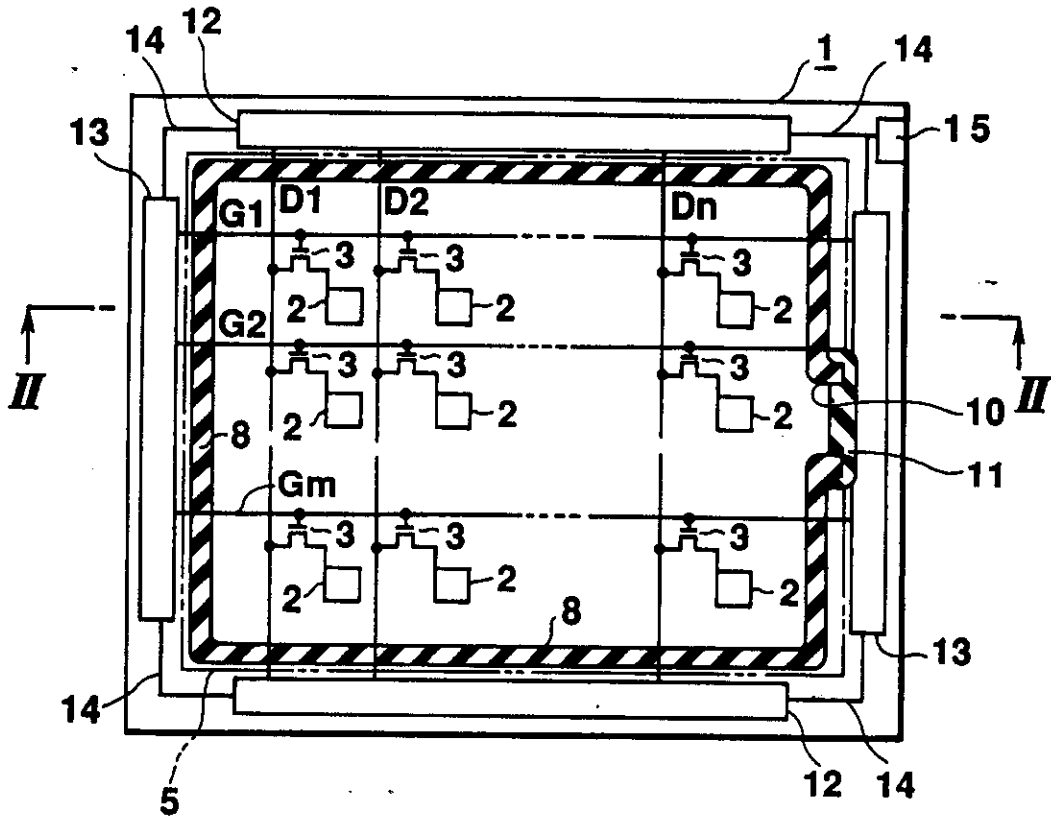

**FIG. 1**  
(PRIOR ART)

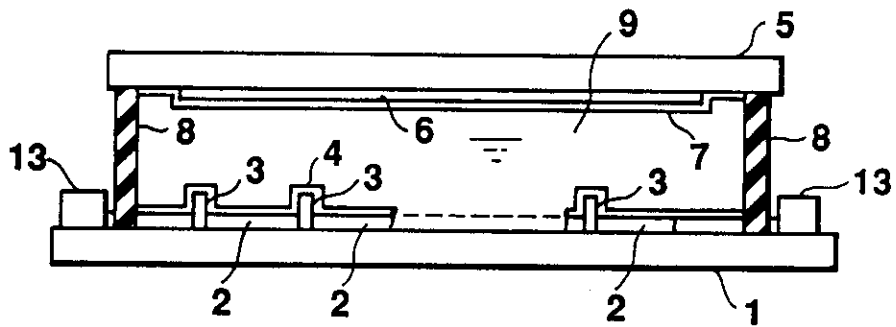

**FIG. 2**  
(PRIOR ART)

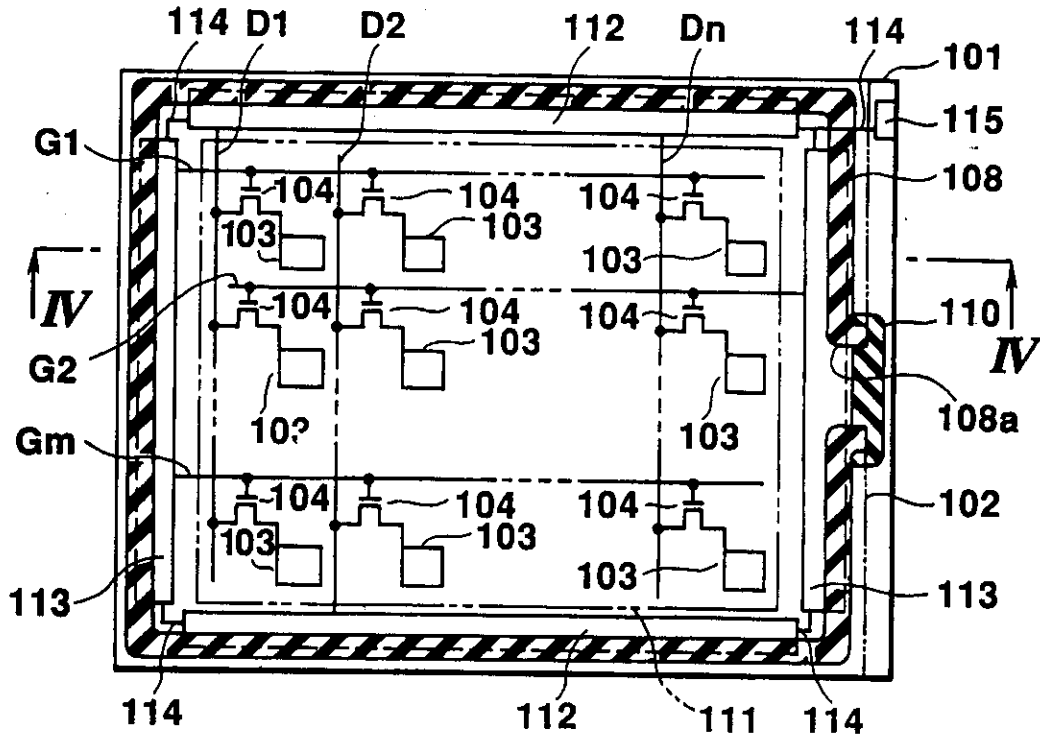

**FIG. 3**

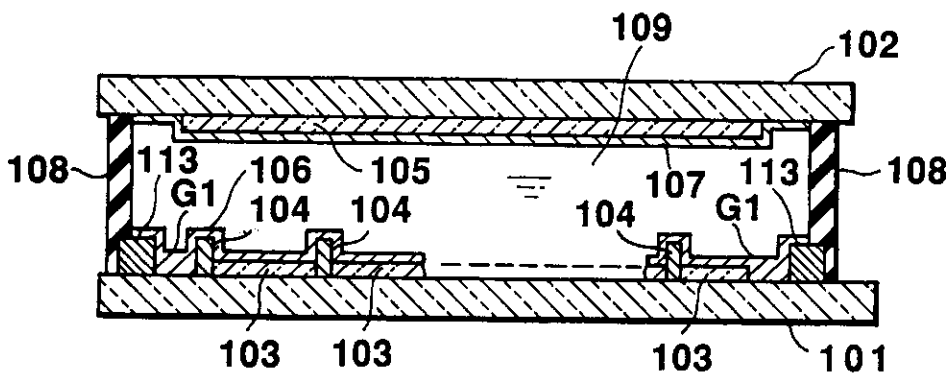

**FIG. 4**

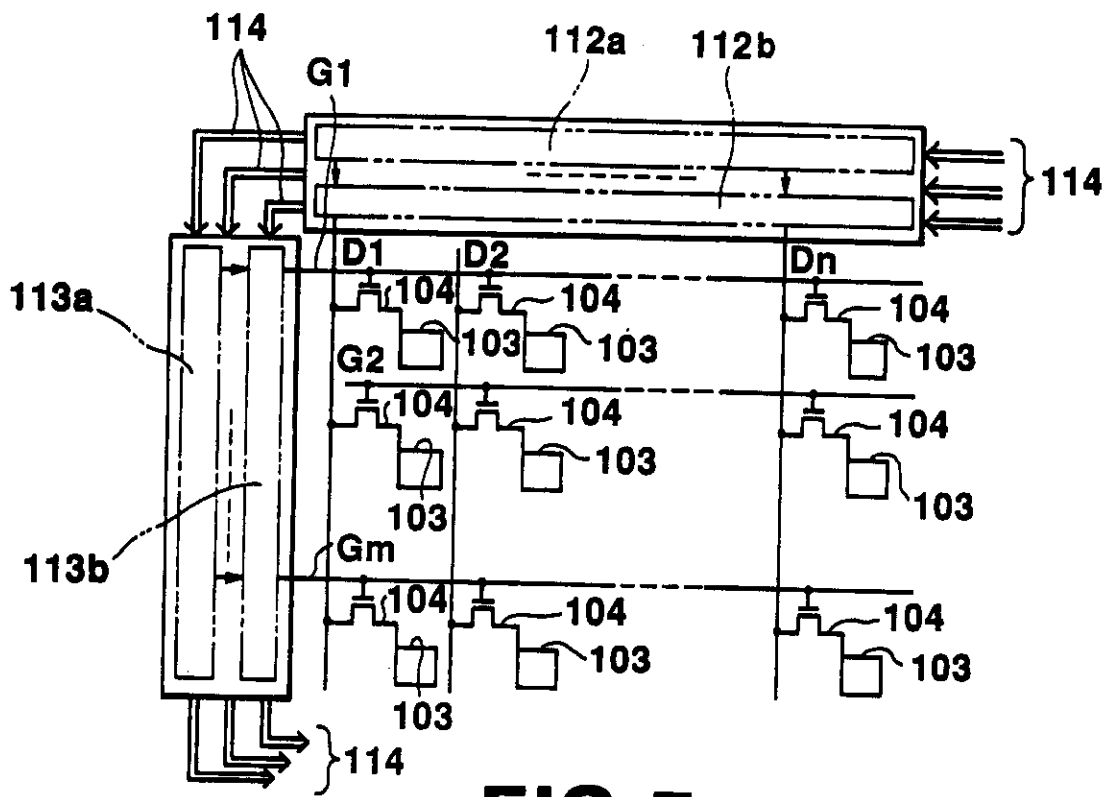

**FIG. 5**

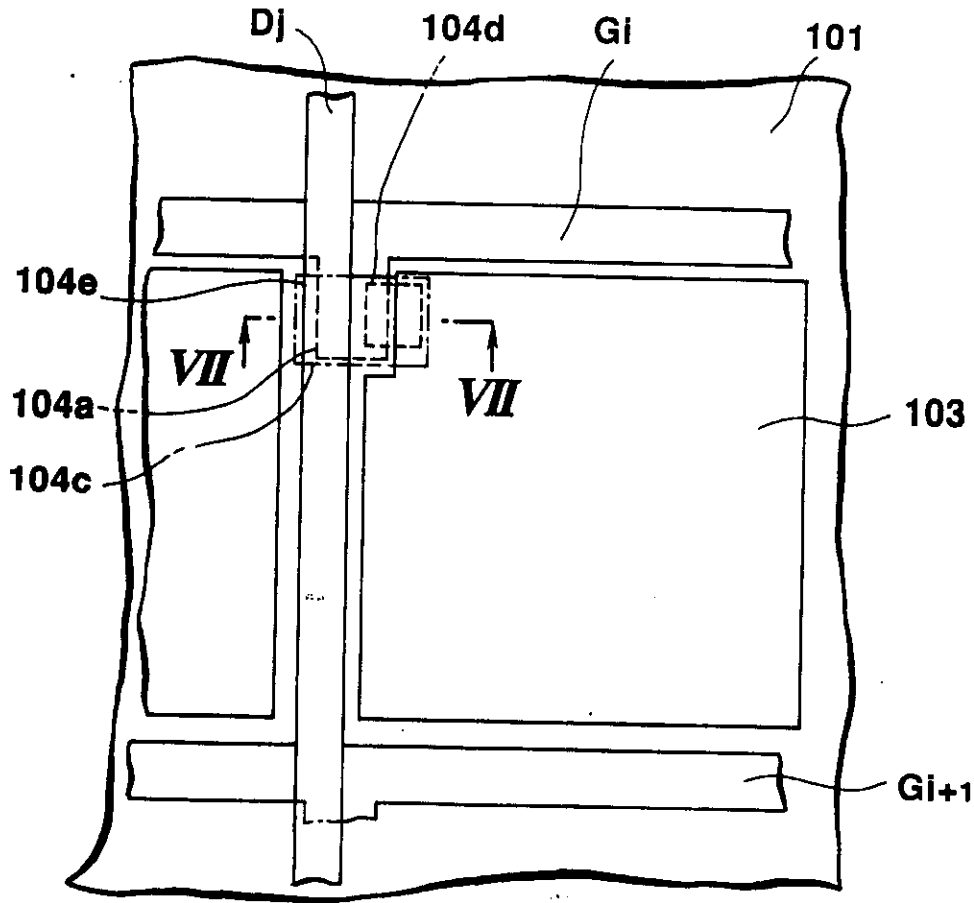

**FIG. 6**

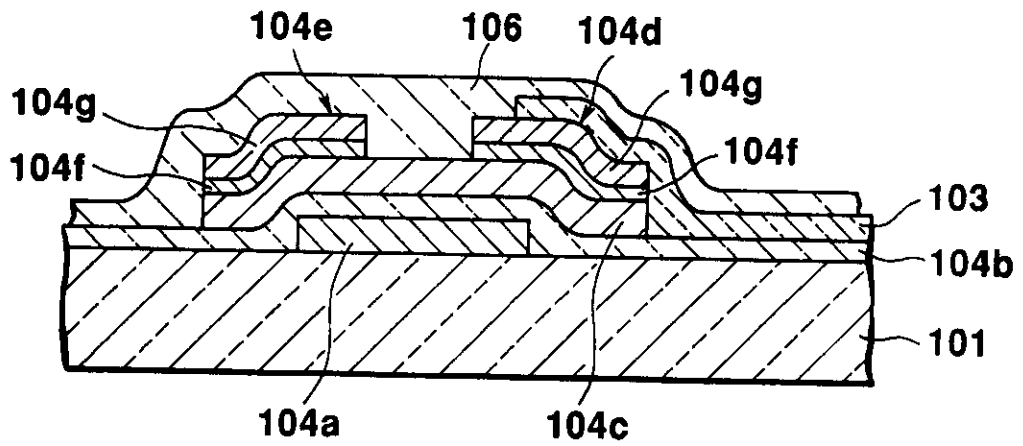

**FIG. 7**

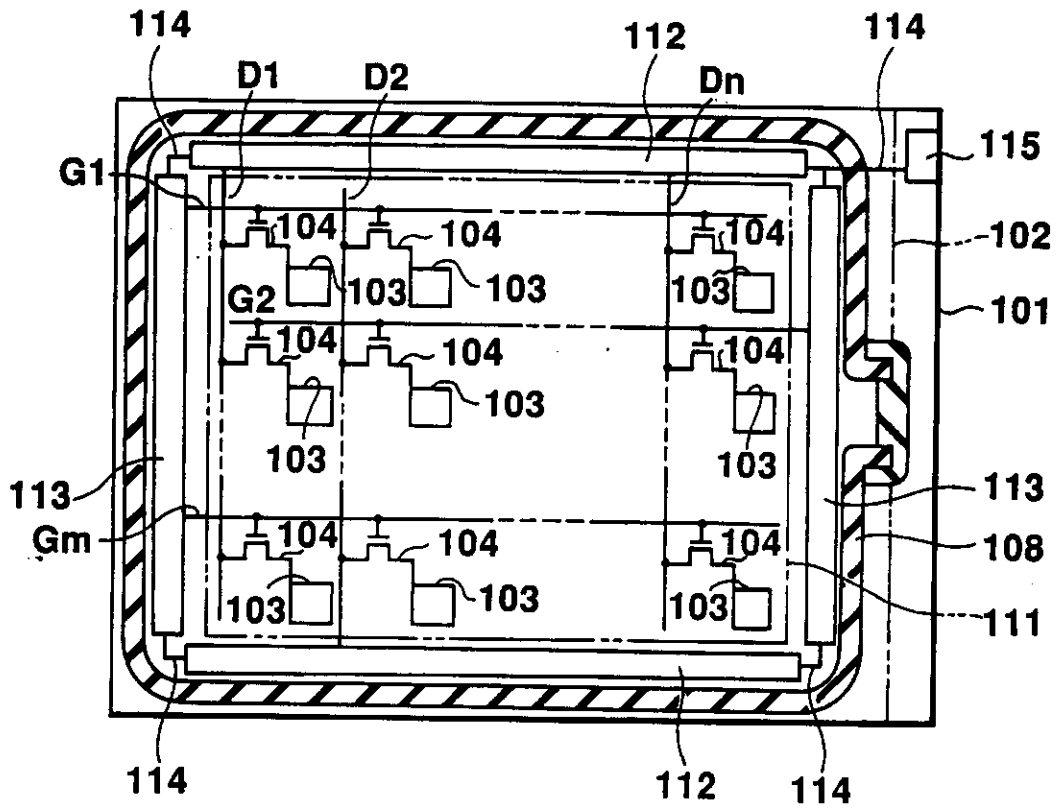

**FIG. 8**

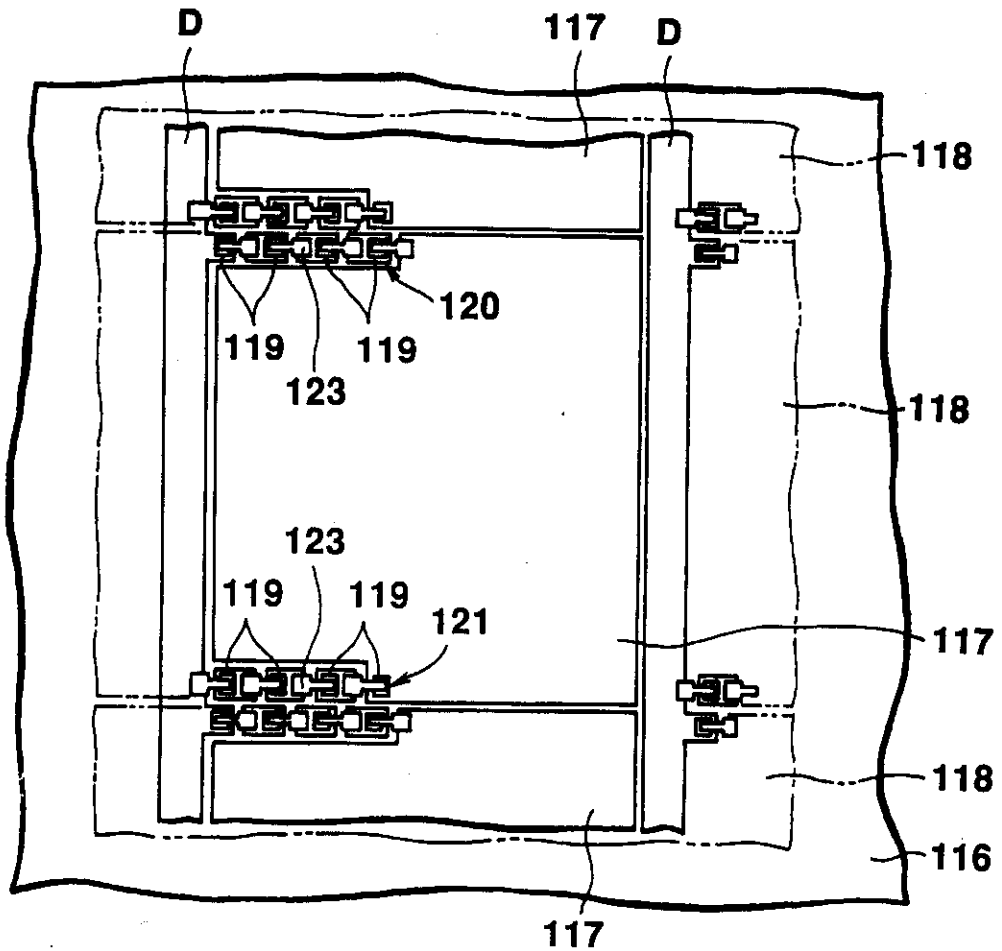

**FIG. 9**

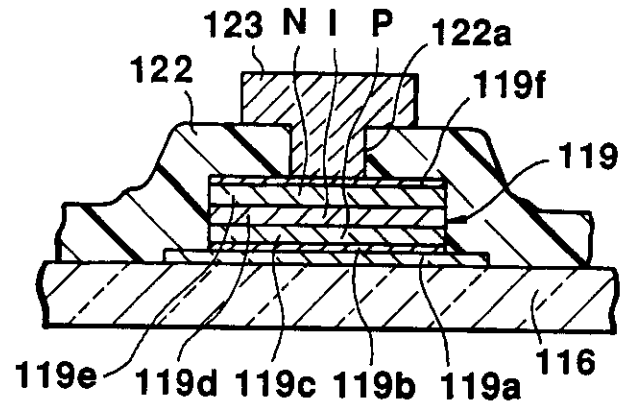

**FIG.10**

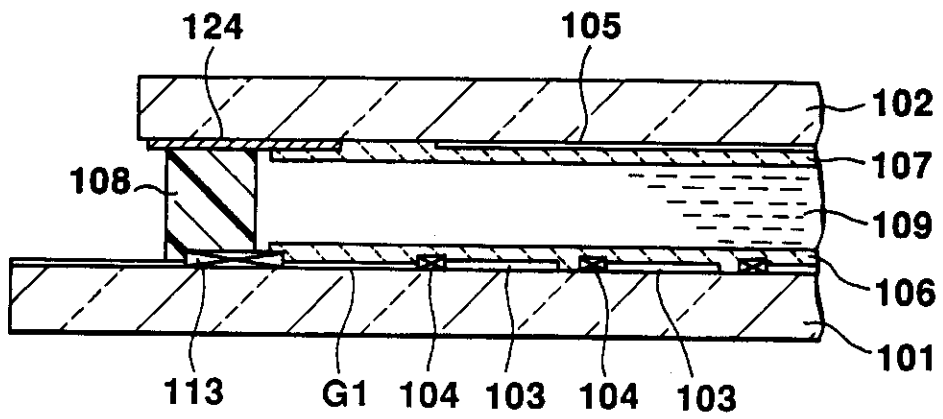

**FIG.11**

REGISTER ENTRY FOR EP0444621

European Application No EP91102834.8 filing date 26.02.1991

Priorities claimed:

27.02.1990 in Japan - doc: 02018227U

01.05.1990 in Japan - doc: 02045085U

Designated States DE FR GB IT NL

Title LIQUID CRYSTAL DISPLAY DEVICE HAVING A DRIVING CIRCUIT.

Applicant/Proprietor

CASIO COMPUTER COMPANY LIMITED, 6-1, 2-chome, Nishi-Shinjuku, Shinjuku-ku  
Tokyo, Japan [ADP No. 50741990001]

Inventors

TAKESHI SAWATSUBASHI, c/o Pat. Dep. Dev. Div., Casio, Computer Co., Ltd.,  
3-2-1, Sakae-cho, Hamura-machi, Nishitama-gun, Tokyo 190-11, Japan  
[ADP No. 58890542001]

ATSUSHI MAWATARI, c/o Pat. Dep. Dev. Div. Casio, Computer Co., Ltd.,  
3-2-1, Sakae-cho, Hamura-machi, Nishitama-gun, Tokyo 190-11, Japan  
[ADP No. 58890559001]

HIROYUKI OKIMOTO, c/o Pat. Dep. Dev. Div. Casio, Computer Co., Ltd.,  
3-2-1, Sakae-cho, Hamura-machi, Nishitama-gun, Tokyo 190-11, Japan  
[ADP No. 58890567001]

Classified to  
G02F

Address for Service

A A THORNTON & CO, Northumberland House, 303-306 High Holborn, LONDON,  
WC1V 7LE, United Kingdom [ADP No. 00000075001]

EPO Representative

PATENTANWÄLTE GRÜNECKER, KINKELDEY, STOCKMAIR & PARTNER, Maximilianstrasse  
58, W-8000 München 22, Federal Republic of Germany [ADP No. 50628205001]

Publication No EP0444621 dated 04.09.1991

Publication in English

Examination requested 26.02.1991

Patent Granted with effect from 13.09.1995/(Section 25(1)) with title LIQUID  
CRYSTAL DISPLAY DEVICE HAVING A DRIVING CIRCUIT.

---

06.04.1992 EPO: Search report published on 06.05.1992

Entry Type 25.11 Staff ID. RD06 Auth ID. EPT

- 11.08.1995 Notification from EPO of change of Applicant/Proprietor details  
from  
CASIO COMPUTER COMPANY LIMITED, 6-1, 2-chome, Nishi-Shinjuku,  
Shinjuku-ku Tokyo, Japan [ADP No. 50741990001]  
to  
CASIO COMPUTER COMPANY LIMITED, 6-1, 2-chome, Nishi-Shinjuku,  
Shinjuku-ku Tokyo 160, Japan [ADP No. 50741990001]  
Entry Type 25.14 Staff ID. RD06 Auth ID. EPT
- 11.08.1995 Notification from EPO of change of EPO Representative details from  
PATENTANWÄLTE GRÜNECKER, KINKELDEY, STOCKMAIR & PARTNER,  
Maximilianstrasse 58, W-8000 München 22, Federal Republic of  
Germany [ADP No. 50628205001]  
to  
GRÜNECKER, KINKELDEY, STOCKMAIR & SCHWANHÄUSSER ANWALTSSOZIETÄT,  
Maximilianstrasse 58, D-80538 München, Federal Republic of Germany  
[ADP No. 50628205001]  
Entry Type 25.14 Staff ID. RD06 Auth ID. EPT

\*\*\*\* END OF REGISTER ENTRY \*\*\*\*

OA80-01  
EP

OPTICS - PATENTS

07/02/97 10:38:15  
PAGE: 1

RENEWAL DETAILS

PUBLICATION NUMBER EP0444621

PROPRIETOR(S)

CASIO COMPUTER COMPANY LIMITED, 6-1, 2-chome, Nishi-Shinjuku,  
Shinjuku-ku Tokyo 160, Japan

DATE FILED 26.02.1991

DATE GRANTED 13.09.1995

DATE NEXT RENEWAL DUE 26.02.1997

DATE NOT IN FORCE

DATE OF LAST RENEWAL 19.02.1996

YEAR OF LAST RENEWAL 06

STATUS PATENT IN FORCE

\*\*\*\* END OF REPORT \*\*\*\*