

(19) World Intellectual Property
Organization
International Bureau



(43) International Publication Date
13 January 2005 (13.01.2005)

PCT

(10) International Publication Number
WO 2005/003569 A1

(51) International Patent Classification⁷: **F04D 29/54**

(21) International Application Number:
PCT/KR2004/001610

(22) International Filing Date: 1 July 2004 (01.07.2004)

(25) Filing Language: Korean

(26) Publication Language: English

(30) Priority Data:
10-2003-0044222 1 July 2003 (01.07.2003) KR

(71) Applicant (for all designated States except US): **HALLA CLIMATE CONTROL CORPORATION** [KR/KR];
1689-1, Sinil-dong, Daedeok-gu, Daejeon-si 306-230 (KR).

(72) Inventors; and

(75) Inventors/Applicants (for US only): **CHO, Kyungseok** [KR/KR]. **PARK, Seyoung** [KR/KR].

(74) Agents: **PARK, Wonyong** et al.; 5 Floor, Shinwon Bldg., 823-14, Yeoksam 1-dong, Gangnam-gu, Seoul 135-933 (KR).

(81) Designated States (unless otherwise indicated, for every kind of national protection available): AE, AG, AL, AM, AT, AU, AZ, BA, BB, BG, BR, BW, BY, BZ, CA, CH, CN, CO, CR, CU, CZ, DE, DK, DM, DZ, EC, EE, EG, ES, FI, GB, GD, GE, GH, GM, HR, HU, ID, IL, IN, IS, JP, KE, KG, KP, KZ, LC, LK, LR, LS, LT, LU, LV, MA, MD, MG, MK, MN, MW, MX, MZ, NA, NI, NO, NZ, OM, PG, PH, PL, PT, RO, RU, SC, SD, SE, SG, SK, SL, SY, TJ, TM, TN, TR, TT, TZ, UA, UG, US, UZ, VC, VN, YU, ZA, ZM, ZW.

(84) Designated States (unless otherwise indicated, for every kind of regional protection available): ARIPO (BW, GH, GM, KE, LS, MW, MZ, NA, SD, SL, SZ, TZ, UG, ZM, ZW), Eurasian (AM, AZ, BY, KG, KZ, MD, RU, TJ, TM), European (AT, BE, BG, CH, CY, CZ, DE, DK, EE, ES, FI, FR, GB, GR, HU, IE, IT, LU, MC, NL, PL, PT, RO, SE, SI, SK, TR), OAPI (BF, BJ, CF, CG, CI, CM, GA, GN, GQ, GW, ML, MR, NE, SN, TD, TG).

Published:
— with international search report

For two-letter codes and other abbreviations, refer to the "Guidance Notes on Codes and Abbreviations" appearing at the beginning of each regular issue of the PCT Gazette.

(54) Title: GUIDE BLADE OF AXIAL-FLOW FAN SHROUD

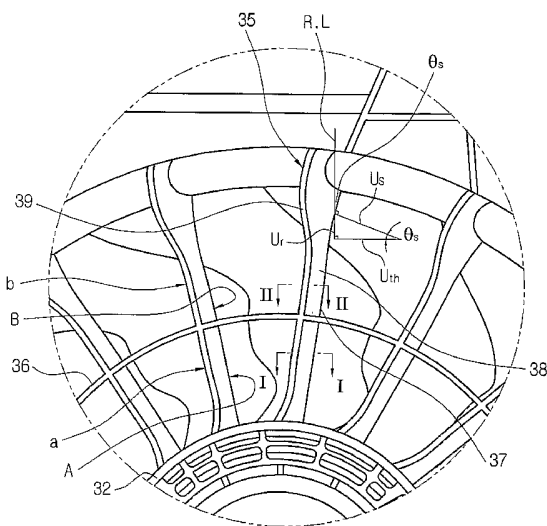

(57) Abstract: The present invention discloses guide blades of an axial flow fan shroud for guiding the air blown by an axial flow fan in an axial direction, and more particularly, to a guide blade structure capable of preventing the backflow of high temperature heat from an engine room toward a condenser. A guide blade 35 of an axial flow fan shroud 30 comprises: a leading edge 37 for introducing the air blown by an axial flow fan 10 including a number of blades 12; a trailing edge 39 extended from the leading edge 37 to downstream; and an air flow guide surface 38 for guiding the blown air between the leading and trailing edges 37 and 39, wherein if a first outlet area a is defined by at a radius r from a root in the total length R of an angle of projection A_{out} of the guide blade 35 and a second outlet area b is defined by the remainder, the angle of projection A_{out} increases as approaching a tip with respect to an axial line in the second outlet area b.

WO 2005/003569 A1

GUIDE BLADE OF AXIAL-FLOW FAN SHROUD

Technical Field

The present invention relates to guide blades of an axial
5 flow fan shroud for guiding the air blown by an axial flow fan
in an axial direction, and more particularly, to a guide blade
structure capable of preventing high temperature heat generated
by an engine room from flowing backward to a condenser.

10 **Background Art**

An axial flow fan is an apparatus for rotating a number
of radially arrayed blades to blow the air in an axial direction,
and includes a shroud which serves to guide the air blew in by
the axial flow fan directly backward.

15 The axial flow fan is used to ventilate a room or to feed
the air into an air-cooled heat exchanger such as a radiator
or condenser of an automobile in order to promote the heat
dissipation thereof.

In the meantime, the shroud includes a number of
20 strip-shaped and fixed guide blades which are arrayed radially
from the central axis of the axial flow fan in order to raise
the blowing efficiency of the axial flow fan. The guide blades
converts the kinetic energy of the air blown from blades of the
axial flow fan into pressure energy to raise static pressure
25 thereby elevating axial blowing efficiency.

Hereinafter the structure of the axial flow fan will be
described in more detail.

FIG. 1 illustrates a rear view of an axial flow shroud
assembly adopted in a conventional condenser for an automobile.

30 As shown in FIG. 1, an axial flow fan 100 includes an annular
fan hub 220 connected to a drive shaft 210 of a motor 200 and

a number of blades 120 arrayed around and integrally with the fan hub 220. In the aspect of blowing efficiency, the axial flow fan 100 is typically installed in the rear of a condenser. Of course, the axial flow fan 100 may adopt a pusher type which
5 is installed in front of the condenser in case that a sufficient installation space is not obtained in the rear of a heat exchanger within an engine room.

In the axial flow fan 100, the motor 200 turns the blades 120 in the rear of the condenser to blow in the air from the
10 front of the heat exchanger through the heat exchanger to introduce the air rearward so that the air blew in by the axial flow fan 100 deprives the hot condenser of heat to cool the same. The axial flow fan 100 is generally made of synthetic resin, and integrally molded so that the fan hub 220 and the blades
15 120 are formed of a single body.

The shroud 300 functions to fix the axial flow fan 100 including the motor 200 with respect to the heat exchanger, and to introduce the air blew in by the axial flow fan 100 directly
20 backward. The shroud 300 includes a substantially rectangular housing 310, a motor support ring 320 provided in the center of the housing 310 and a number of guide blades 330 arrayed substantially radially for supporting the motor support ring 320 with respect to the housing 310.

The guide blades 330 of the shroud 300 are connected to
25 the motor support ring 320, and as shown in FIG. 1, obliquely inclined in the turning direction of the axial flow fan 100 to form air flow guide surfaces 332 of a predetermined area in order to vary the blown air in an axial direction to increase the quantity of the axially blown air.

30 That is, the guide blades 330 are straightly extended from the outer circumference of the motor support ring 320 toward

the housing 310, and inclined at a predetermined angle θ_t with respect to the axial direction as shown in FIG. 2, as a schematic plan view of a single guide blade 330, so that the air flow guide surfaces 332 formed in the rear faces of the guide blades 330 can directly change the flowing direction of the air. As shown in the sectional view, the single guide blade 330 includes a leading edge 331 for introducing the air, a trailing edge 333 for exhausting the air to the outside and an air flowing guide face 332 connecting the leading edge 331 with the trailing edge 333.

The air flowing guide face 332 converts the rotation velocity component of the air into the axial direction to increase the axial velocity of the air thereby raising the blowing efficiency of the axial flow fan 100. That is, because the air blown by the axial flow fan 100 has not only an axial velocity component U_z but also a rotational axial velocity component U_{th} , the rotational velocity component U_{th} may lower the blowing efficiency if left alone. Thus, the rotational velocity component U_{th} is converted into the axial direction to enhance the axial blowing velocity thereby raising the blowing efficiency of the axial flow fan 100.

The operation of the air flow guide surface 332 of the each guide blade will be described in more detail with reference to FIG. 2. Since an air particle in a flow field spaced from the center of gyration at any distance has an axial velocity component U_z and a rotational velocity component U_{th} by the rotational force of the blade 320 with respect to the axial direction, the air particle is blown toward the leading edge 331 of the guide blade 330 in a direction inclined to a specific angle θ_T in a rotating direction with respect to an axial line A.L which is actually parallel with the axial direction.

Regarding the actual blowing direction, the air flow guide surface 332 of the guide blade 330, in view of the section in a breadth direction, is designed into a curve inclined at an angle θ_t ($\theta_t \leq \theta_T$) in the counter-rotating direction of the axial flow fan 100, that is, the air exhausting direction with respect to the axial line A.L. Then, the air flow guide surface 332 refracts the air blown by the axial flow fan 100 in the axial direction thereby to increase the axial velocity of the air. The increase in the axial velocity of the blown air means the enhancement of blowing efficiency. As a result, in the design of the guide blade 330, the air flow guide surface 332 which is inclined in the counter-rotating direction with respect to the axial direction serves to enhance the blowing efficiency of the axial flow fan.

Considering the actual blowing speed, several approaches which can enhance the blowing speed through the variation of the configuration of the guide blade 330 have been studied in various aspects.

United States Patent Serial No. 4,548,548 discloses an invention which substantially limits an inclination angle with respect to an axial line of an air flow guide surface of a guide blade to further enhance the blowing efficiency.

That is, at a point in a flow field that is spaced from the center of gyration at a distance r in a radial direction, a velocity vector of an air particle has an axial velocity component A and a rotational velocity component R by the blade-turning force of the axial flow fan. The velocity vector A_0 has an inclination angle $T = \tan^{-1}(R/A)$ with respect to the axial line. Regarding the inclination angle, the guide blade is so arranged that the normal line of the central portion thereof is inclined at an angle $T/2$ with respect to the axial line, and

the air flow guide surface is curved to have a substantially arc-shaped section. In this way, the air flow guide surface introduces the blown air at the inclination angle $T/2$ in the center, and then refracts the blown air for the inclination angle $T/2$ to the axial direction. As a consequence, the axial velocity of the air blown by the axial flow fan is increased in proportion with the rotational velocity component R which is converted into the axial direction. That is, the air flow guide surface of the guide blade enhances the quantity of the air blown by the flow fan in proportion with the rotational velocity component of the air particle that is converted into the axial direction.

In the meantime, the air blown by the axial flow fan has a radial velocity component U_r by the centrifugal force of the axial flow fan in addition to the axial velocity component U_z and the rotational velocity component U_{th} . An approach for converting the rotational velocity component U_{th} and the radial velocity component U_r into the axial velocity component U_z to enhance the blowing efficiency is disclosed in United States Patent Serial No. 6,398,492 which was filed by the inventor of the present invention.

The guide blade of the present invention is arranged radially with respect to the central axis of the axial flow fan, and bent radially with respect to a radial line so that a leading edge line intersects perpendicularly with a lateral velocity vector U_s that is the sum of the rotational velocity vector U_{th} and the radial velocity vector U_r . Further, the angle of incidence of the guide blade is the same as an air inflow angle $\tan^{-1}(U_s/U_z)$, that is the angle of the air introduced to the guide blade, and the angle of projection of the guide blade is curved at 0° with respect to the axial line.

The prior art as above can enable the use of a low power

motor by enhancing the axial blowing efficiency in order to reduce the power consumption necessary for the air blowing as well as to restrain noises during the air blowing. However, since the angle of projection of the guide blade is 0° with respect to the axial line, the air passing through the axial flow fan is guided toward the engine in the rear in the axial direction of the fan colliding into the engine so that high temperature heat generated by the engine flows backward toward the heat exchanger such as a condenser to elevate the refrigerant pressure of the heat exchanger thereby disadvantageously degrading the performance of an air conditioning system.

Disclosure of the Invention

The present invention has been devised to solve the foregoing problems occurring in the prior art, and it is therefore an object of the present invention to provide a guide blade of an axial flow fan shroud which converts both of rotational and radial velocity components of the air blown by an axial fan into an axial direction to spread in radial and rotational directions to enhance the blowing efficiency in the axial direction as well as to prevent high temperature heat generated by an engine room from flowing backward to a heat exchanger such as a condenser thereby improving the performance of an air conditioning system.

According to an aspect of the invention for realizing the object, there is provided a guide blade of an axial flow fan shroud comprising: a leading edge for introducing the air blown by an axial flow fan including a number of blades; a trailing edge extended from the leading edge to downstream; and an air flow guide surface for guiding the blown air between the leading and trailing edges, wherein if a first outlet area a is defined

by at a radius r from a root in the total length R of an angle of projection A_{out} of the guide blade and a second outlet area b is defined by the remainder, the angle of projection A_{out} increases as approaching a tip with respect to an axial line
5 in the second outlet area b .

Preferably, the second outlet area b has a radial ratio r/R in the range of about 0.4 to 1 with respect to the total length R of the guide blade 35, and the angle of projection A_{out} gradually increases from 0 to about 60° .

10 Preferably, if a first inlet area A is defined by at a radius r from a root in the total length R of an angle of incidence A_{in} of the guide blade 35 and a second inlet area B is defined by the remainder, the second inlet area B has a radial ratio r/R in the range of about 0.4 to 1 with respect to the total
15 length R of the guide blade 35, and the angle of incidence A_{in} gradually increases up to about 90° in the second inlet area B .

Preferably, the air flow guide surface 38 is so curved that the angle of incidence A_{in} is the same as an air inflow angle $\tan^{-1}(U_s/U_z)$ in the first inlet area A , and the angle of
20 projection A_{out} is 0° with respect to the axial line.

Brief Description of the Drawings

FIG. 1 is a rear view of a conventional axial flow fan shroud assembly;

25 FIG. 2 is a schematic plan sectional view of a guide blade at a point spaced from the central axis in a conventional axial flow fan shroud assembly;

FIG. 3 is rear view of an axial flow fan shroud assembly of the present invention;

30 FIG. 4 is a side elevation view of the axial flow fan shroud assembly in FIG. 3;

FIG. 5 is an enlargement of guide blades according to the present invention;

FIG. 6 illustrates velocity components at a point spaced from the central axis of the shroud according to the present invention;

FIG. 7 illustrates an air flow structure of a guide blade seen from the rear in a direction perpendicular to an axial line A.L of FIG. 5;

FIG. 8 is a schematic plan sectional view illustrating a guide blade taken along a line I-I in FIG. 5;

FIG. 9 is a schematic plan sectional view illustrating a guide blade taken along a line II-II in FIG. 5; and

FIG. 10 is a graph for comparing design factors of angles of incidence and projection about a guide blade radius ratio r/R of the present invention with those of the prior art.

Best Mode for Carrying Out the Invention

Hereinafter a preferred embodiment of the present invention will be described in detail with reference to the accompanying drawings.

The same or similar parts are designated with the same or similar reference numerals as in the prior art, and repeated description thereof will be omitted.

FIGS. 3 and 4 illustrate an axial flow fan shroud assembly of the present invention, in which an axial flow fan 10 and a shroud 30 are assembled into an integral unit.

The axial flow fan 10 includes an annular fan hub 11 and a number of blades 12 arrayed along the outer circumference of the fan hub 11 at a predetermined gap. The shroud 30 includes a motor support ring 32, guide blades 35 and a housing 31.

As shown in FIG. 4, the axial flow fan 10 is integrally provided with a fan band 13 which is coaxial with the fan hub

11. The fan band 13 fixedly connects the ends of the blades 12 to restrain vortex at the ends of the blades 12 thereby enhancing the blowing efficiency. The axial flow fan 10 is typically made of synthetic resin into a unitary form, but alternatively may
5 be molded from light aluminum and so on.

In the meantime, the front end of the fan band 13 of the axial flow fan 10 is expanded into the form of a bell mouth and extended into a U-shaped configuration from the rear end of the housing 31 of the shroud 30 to upstream to form an air
10 introduction part 13a to surround the front end of an air guide part 31b.

In the housing 31 of the shroud 30, the front of is rectangular shaped to span the entire rear part of the heat exchanger, and the periphery is projected to a predetermined
15 height to ensure an air flow space between the rear part of the heat exchanger. The housing 31 is reduced to downstream to form a circular vent hole 31a, and has a side section shaped as a bell mouth which is widened to upstream and reduced to downstream.

20 The motor support ring 32 is arranged in the center of the vent hole 31a of the housing 31 so that the axial flow fan 10 is fixed together with the motor 20. The motor support ring 32 has an annular shape as the fan hub 11 of the axial flow fan 10 and the motor 20.

25 As shown in FIG. 3, the guide blades 35 are arrayed radially between the motor support ring 32 and the housing 31 to fixedly support the motor support ring 32 with respect to the housing 31 in the center of the vent hole 31a and to introduce the three-dimensional air, which is blown from the axial flow fan
30 10, into a one-dimensional direction in order to enhance the blowing efficiency of the axial flow fan 10 as well as to restrict

blowing noises.

FIG. 5 illustrates the structure of the guide blades 35 in detail. Each of the guide blades 35 forms an arc having a predetermined area defined by a leading edge 37 placed in the leading end for introducing the air, an air flow guide surface 38 extended to downstream from the leading edge 37 and a trailing edge 39 placed in the rear end of the air flow guide surface 38. Since the arc is curved and obliquely inclined with respect to an axial direction, the air blown by the axial flow fan 10 can be efficiently refracted and introduced to the air flow guide surface 38.

Further, the each guide blade 35 of the present invention is radially curved so that the axial flow fan 10 can efficiently receive and convert the three-dimensional air into the axial direction.

In the meantime, the guide blades 35 are provided integrally with an auxiliary ring 36 which connects and supports the individual guide blades 35. Each of the guide blades 35 is partitioned into a first inlet section A, a first outlet section a, a second inlet section B and a second outlet section b on the basis of the auxiliary ring 36.

Before determining the configuration of the each guide blade 35 of the present invention, the velocity of the air blown by the axial flow fan 10 will be analyzed as the most important factor for determining the configuration.

FIG. 6 illustrates a velocity component of the air at a point P in the vent hole 31a spaced from the center. The air blown by the axial flow fan flows with an axial velocity component U_z , a rotational velocity component U_{th} and a radial velocity component U_r by the centrifugal force of the axial flow fan 10.

Since the air blown by the axial flow fan 10 necessarily

has the axial velocity component U_z , the rotational velocity component U_{th} and a radial velocity component U_r , the actual velocity vector U of an air particle blown at the point P becomes the sum of the axial velocity component U_z , the rotational velocity component U_{th} and the radial velocity component U_r as shown in FIG. 6. In the velocity vector U of the air particle, a lateral velocity vector U_s as the sum of the rotational velocity component U_{th} and the radial velocity component U_r is inclined at a specific angle Θ with respect to an axial line in parallel with the rotation axis, wherein $\Theta = \tan^{-1}(U_s/U_z)$. That is, the air particle blowing in the point P has the lateral velocity component U_s , and thus is biased to the rotational and radial directions of the axial flow fan 10.

With respect to the actual velocity vector U of the air particle blown as above, the guide blade 36 is preferably required to a configuration to:

(1) introduce the lateral velocity vector U_s as the sum of the rotational velocity component U_{th} and the radial velocity component U_r toward the axial direction to enhance the blowing efficiency of the axial flow fan 10, and

(2) spread the air in the rotational and radial directions when the air passes by the guide blade 35 in order to prevent high temperature heat generated from an engine room from flowing back into the heat exchanger such as a condenser.

In order to meet demand as above, the present invention designs the guide blade 35 as follows: According to the radial ratio r/R of the guide blade 35, a portion adjacent to the center of the rotation axis introduces the lateral velocity vector U_s as the sum of the rotational velocity component U_{th} and the radial velocity component U_r in the lateral direction to enhance the blowing efficiency of the axial flow fan 10. In a portion away

from the center of the rotation axis, the guide blade 35 spreads the air in the rotational and radial directions to prevent the collision of the air into an engine and resultant backflow thereof thereby enhancing the performance of an air conditioning
5 system.

As a consequence, it is preferable to divide the guide blade 35 into two sections in order to realize the guide blade 35 which satisfies above conditions.

In addition, for the sake of understanding, when a tangent
10 line contacts the leading and trailing edges 37 and 39 of the guide blade 35, cross angles with respect to the axial line will be referred to as an angle of incidence A_{in} and an angle of projection A_{out} , respectively.

Where a first inlet area A is defined by a radius r from
15 a root in the total length R of the angle of incidence A_{in} of the guide blade 35 and a second inlet area B is defined by the remainder, the angle of incidence A_{in} preferably increases as approaching a tip from the second inlet area B with respect to the axial line.

In the first inlet area A, an r/R as a ratio of the radius
20 r with respect to the total length R of the guide blade 35 preferably corresponds to about 0 to 0.4. In the second inlet area B, an r/R as a ratio of the radius r with respect to the total length R of the guide blade 35 preferably corresponds to
25 about 0.4 to 1.

Further, where a first outlet area a is defined by a radius
 r from a root in the total length R of the angle of projection
 A_{out} of the guide blade 35 and a second outlet area b is defined
by the remainder, the angle of projection A_{out} preferably
30 increases as approaching a tip from the second outlet area b
with respect to the axial line.

In the first outlet area a, an r/R as a ratio of the radius r with respect to the total length R of the guide blade 35 preferably corresponds to about 0 to 0.4. In the second outlet area b, an r/R as a ratio of the radius r with respect to the total length R of the guide blade 35 preferably corresponds to about 0.4 to 1.

According to typical experiment results, in a range up to about $r/R \doteq 0.4$ as the first inlet area A and the first outlet area a that are more adjacent to the center of axis, the blowing area of the air is relatively narrow and the centrifugal force is small. Then, this induces the lateral velocity component U_s as the sum of the rotational velocity component U_{th} and the radial velocity component U_r in the axial direction. In a range from $r/R \doteq 0.4$ as the second inlet area B and the second outlet area b, the centrifugal force acts in larger values as becoming farther away from the center of the axis, and thus the lateral velocity component U_s spreads in both of the rotational and radial directions.

FIG. 7 schematically illustrates an air flow structure of the guide blades taken along a line I-I of FIG. 5, seen in a rear view or from a direction perpendicular to the axial line A.L. In this structure, it is preferable to induce the lateral velocity component U_s as the sum of the rotational velocity component U_{th} and the radial velocity component U_r in the axial direction to obtain the maximum efficiency.

The guide blade 35 maintains an angle perpendicular to the lateral velocity component U_s so that its L.E.L can effectively receive the lateral flow of the air. Since the guide blade 35 is so curved that contact lines of the L.E.L at respective points of the guide blade 35 have an inclination angle θ_s of the lateral velocity component U_s , wherein $\theta_s = \text{Tan-1}(U_r/U_{th})$, it has a

changing curvature in which the center is curved in the rotational direction of the axial flow fan blade 12 when seen in general.

Now discussion will be made with respect to a plan sectional view which maximizes the blowing efficiency at a point P from the center of the axial flow fan in the range up to about $r/R \approx 0.4$ as the first inlet area A and the first outlet area a.

FIG. 8 schematically illustrates the plan view of the blade 12 and the guide blade 35 at a point P from the center of the axial flow fan taken along the line I-I of FIG. 5 for more detailed understanding of the configuration of the plan sectional view.

The air flow guide surface 38 of the guide blade 35 serves to axially refract the air having the lateral velocity component U_s that is obliquely blown by the leading edge 37. In order that the blown air is introduced in parallel to the leading edge 37, the angle of incidence A_{in} is made the same as an angle of projection B_{out} of the blade 12 that is an angle of introduction of the blown air introduced to the leading edge ($A_{in} = B_{out}$). The angle of projection A_{out} is designed at 0° or parallel with the axial line A.L so that the air is blown in the axial direction. The air flow guide surface 38 is curved in the form of an arc to connect between the leading edge 37 and the trailing edge 39.

That is, the air flow guide surface 38 is so curved that the angle of incidence A_{in} becomes the same as an air inflow angle $\tan^{-1}(U_s/U_z)$ in the first inlet area A and the angle of projection A_{out} becomes 0° with respect to the axial line in the first outlet area a.

As a consequence, in the leading edge 37 of the guide blade 35 at the point P spaced from the center of the axis taken along the line I-I, the air blown by the axial flow fan 10 is introduced

in a direction inclined at the angle of projection θ ($\tan^{-1}(U_s/U_z)$) that is defined by the velocity vector U (i.e., a resultant vector of the lateral velocity component U_s and the axial velocity component U_z) and the axial line A.L.
5 Corresponding to the angle of projection θ , the leading edge 37 of the guide blade 35 is obliquely set at the angle of incidence θ with respect to the axial line, and the trailing edge 39 is set parallel with the axial line.

The air flow guide surface 38 between the leading edge 37
10 and the trailing edge 39 has the same radius as a circle which has a center at a point q intersected by normal lines of the leading and trailing edges 37 and 39 and a radius spaced from the point q to the leading edge 37 or the trailing edge 39. The curvature of the arc minimizes the vortex of the air to more
15 smoothly refract the flow of the air along the air flow guide surface 38 and blow the air in the axial direction.

As described hereinbefore, in the range up to about $r/R \leq 0.4$ as the first inlet area A and the first outlet area a that are more adjacent to the center of axis which is less influenced
20 by the centrifugal force, the guide blade 35 has a changing curvature structure in which the center is curved in the rotational direction of the axial flow fan blade 12 when seen in an axial direction and the air flow guide surface 38 is curved when seen in a plan sectional view so that the air blown by the
25 axial flow fan 10 is introduced in parallel to the leading edge 37, refracted smoothly in the axial direction, and blown through the trailing edge 39.

Since the rotational velocity component U_{th} and the radial velocity component U_r being removed by the guide blade 35 and
30 thus the air blown by the axial flow fan 10 is smoothly blown in the axial direction, the axial flow rate of the air is raised

thereby remarkably enhancing the blowing efficiency of the axial flow fan 10.

In particular, in case of a pusher type axial flow fan 10 which is installed in front of the condenser, the blown air has
5 a high transmissivity about heat dissipating fins of a heat exchanger to further enhance the blowing efficiency.

Now discussion will be made with respect to the configuration of a preferable guide blade 35 in the range from $r/R \doteq 0.4$ as the second inlet area B and the second outlet area
10 b in which the influence of contrary wind from the engine room as well as the blowing efficiency will be considered.

When taken along a line II-II in FIG. 5, it is necessary to induce most of the lateral velocity component U_s as the sum of the rotational velocity component U_{th} and the radial velocity
15 component U_r in the axial direction as well as spread the same in both of the rotational and radial directions.

Of course, the guide blade 35 has a changing curvature structure in which the center is curved in the rotational direction of the axial flow fan blade 12 when seen in an axial
20 direction, substantially the same as that shown taken along the line I-I when seen in the axial direction, except for the configuration seen in a plan view.

Accordingly, discussion will be made with respect to a plan sectional view which maximizes the blowing efficiency at a point
25 P from the center of the axial flow fan 10 in the range from about $r/R \doteq 0.4$ to the tip.

FIG. 9 is a schematic plan sectional view illustrating the blade 12 and the guide blade 35 at a point P from the center of the axial flow fan 10 taken along a line II-II in FIG. 5 in
30 order to explain the configuration of the above plan sectional view.

The air flow guide surface 38 of the guide blade 35 serves to axially refract the air having a lateral velocity component U_s that is introduced obliquely in an outer circumferential direction so that the air is introduced to the leading edge 37 at an angle slightly larger than the parallel angle. In this case, $A_{in} (\theta')$ is made larger than $B_{out} (\theta)$, in which $\theta' > \theta$. The angle of incidence A_{in} is formed larger than the angle of projection B_{out} of the air by the blade 12, that is, the inflow angle of the air that is introduced to the leading edge 37. The angle of projection A_{out} is formed at an angle θ so that the blown air has a lateral component. That is, the angle of projection A_{out} is formed to have an inclination oblique with respect to the axial line A.L.

The guide blade 35 is curved into an arc of a large curvature between the leading edge 37 and the trailing edge 39.

As a consequence, in the leading edge 37 of the guide blade 35 at the point P spaced from the center of the axis taken along the line II-II, the air blown by the axial flow fan 10 is introduced in a direction inclined at the angle of projection $B_{out} (\tan^{-1}(U_s/U_z))$ that is defined by the velocity vector U (i.e., a resultant vector of the lateral velocity component U_s and the axial velocity component U_z) and the axial line A.L. Corresponding to the angle of projection B_{out} , the leading edge 37 of the guide blade 35 is obliquely set at the angle of incidence $A_{in} (\theta')$ with respect to the axial line, and the trailing edge 39 is set parallel with the axial line.

The air flow guide surface 38 between the leading edge 37 and the trailing edge 39 has the same radius as a circle which has a center at a point q intersected by normal lines of the leading and trailing edges 37 and 39 and a radius spaced from the point q to the leading edge 37 or the trailing edge 39. The

curvature of the arc has a small curvature in the vicinity of $r/R \approx 0.4$ but increases as approaching the tip up to a substantially unlimited value.

FIG. 10 is a graph for comparing design factors of the angle of incidence and the angle of projection about the guide blade radius ratio r/R of the present invention with those of the prior art.

As shown in FIG. 10, the angle of projection A_{out} of the prior art is maintained 0° to be parallel with the axial line. However, it is apparent that the angle of projection A_{out} of the present invention increases gradually up to about 0 to 60° with respect to the axial line up to 0.4 to 1 of the radial ratio r/R in the second outlet area b of the guide blade 35.

It is also observed that the angle of incidence A_{in} of the prior art is gradually increased up to the radial ratio r/R of the guide blade 0.5 to 1 with respect to the axial line to have about 60° at the tip. However, the angle of incidence A_{in} of the present invention is gradually increased more sharply than in the prior art up to 0.4 to 1 of the radial ratio r/R with respect to the axial line in the second inlet area B of the guide blade 35 and reaches substantially 90° at the tip where the radius ratio r/R is substantially 1 .

In the vicinity of the tip of the guide blade 35 corresponding to $r/R \approx 1$, the angle of incidence is substantially 90° and the angle of projection is substantially 60° .

As set forth above, in proportion to the increase of the ratio r/R , in the range from $r/R > 0.4$ to $r/R \approx 1$ where the influence of the centrifugal force becomes larger as becoming farther away from the center of the axis, the structure of the guide blade 35 has a changing curvature in which the center is curved in

the rotational direction of the axial flow fan blade 12 when seen in the axial direction. When seen in a plan view, the guide blade 35 has a curved structure in which the inclination of the air flow guide surface 38 gradually increases, and the angle of incidence A_{in} and the angle of projection A_{out} gradually increase.

Accordingly, in the air blown by the axial flow fan 10, the axial flow component gradually decreases and the lateral component gradually increases while the air is introduced parallel with the leading edge 37 in the vicinity of $r/R \doteq 0.4$, smoothly axially refracted along the air flow guide surface 38. As approaching the tip, most of the air flows as spread in the rotational and radial directions so that the air can flow bypassing the engine in the rear of the axial flow fan 10 without collision into the engine in order to prevent high temperature heat generated by the engine from flowing back to the heat exchanger.

As described hereinbefore, while it has been described in the present invention that the guide blade 35 is formed integrally with the motor support ring 32 and the housing 31, the present invention is not limited thereto, but the guide blade 35 can be manufactured separately and then additionally coupled with the motor support ring 32 and the housing 31.

25 **Industrial Applicability**

As set forth above, the guide blade of the shroud of the present invention is so designed that the angles of incidence and projection increase gradually up to 0.4 to 1 of the radial ratio r/R to raise the blowing efficiency while preventing high temperature heat generated by the engine from flowing back to the heat exchanger thereby improving the performance of an air

conditioning system.

What Is Claimed Is:

1. A guide blade 35 of an axial flow fan shroud 30 comprising:

5 a leading edge 37 for introducing the air blown by an axial flow fan 10 including a plurality of blades 12;

a trailing edge 39 extended from the leading edge 37 to downstream; and

an air flow guide surface 38 for guiding the blown air between the leading and trailing edges 37 and 39,

10 wherein a first outlet area a is defined by at a radius r from a root in the total length R of an angle of projection A_{out} of the guide blade 35 and a second outlet area b is defined by the remainder, the angle of projection A_{out} increases as approaching a tip with respect to an axial line in the second
15 outlet area b.

2. The guide blade 35 of an axial flow fan shroud 30 according to claim 1, wherein the second outlet area b has a radial ratio r/R in the range of about 0.4 to 1 with respect
20 to the total length R of the guide blade 35.

3. The guide blade 35 of an axial flow fan shroud 30 according to claim 1, wherein the angle of projection A_{out} gradually increases from 0 to about 60° .

25

4. The guide blade 35 of an axial flow fan shroud 30 according to claim 1, wherein a first inlet area A is defined by at a radius r from the root in the total length R of an angle of incidence A_{in} of the guide blade 35 and a second inlet area
30 B is defined by the remainder, the second inlet area B has a radial ratio r/R in the range of about 0.4 to 1 with respect

to the total length R of the guide blade 35, and the angle of incidence A_{in} gradually increases up to about 90° in the second inlet area B.

5 5. The guide blade 35 of an axial flow fan shroud 30 according to claim 4, wherein the air flow guide surface 38 is so curved that the angle of incidence A_{in} is the same as an air inflow angle $\tan^{-1}(U_s/U_z)$ in the first inlet area A, and the angle of projection A_{out} is 0° with respect to the axial line.

10

6. The guide blade 35 of an axial flow fan shroud 30 according to claim 1, wherein the air flow guide surface 38 is curved into the form of an arc between the leading edge 37 and the trailing edge 39.

15

7. The guide blade 35 of an axial flow fan shroud 30 according to claim 4, further comprising an auxiliary ring 36 formed by a radius r from the root of the total length R of the guide blade 35, the auxiliary ring 36 partitioning the first and second inlet areas A and B and the first and second outlet areas a and b.

20

Figure 2

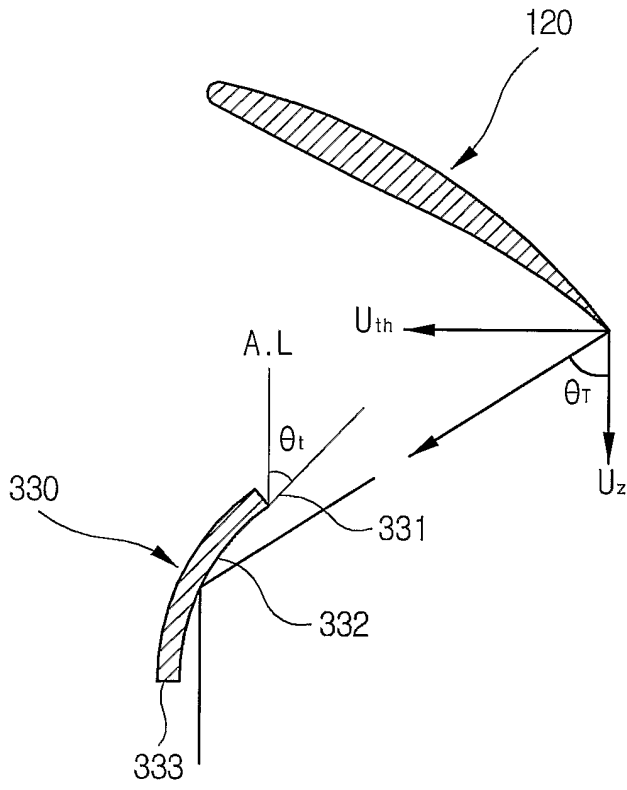

Figure 3

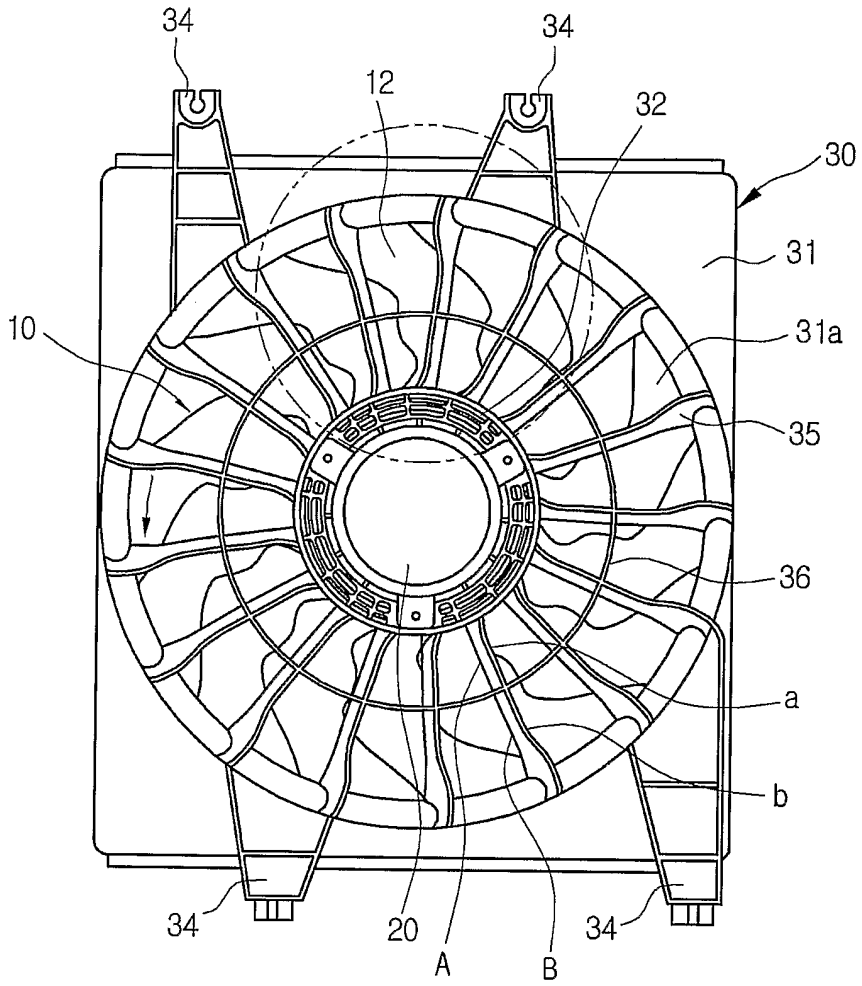

Figure 4

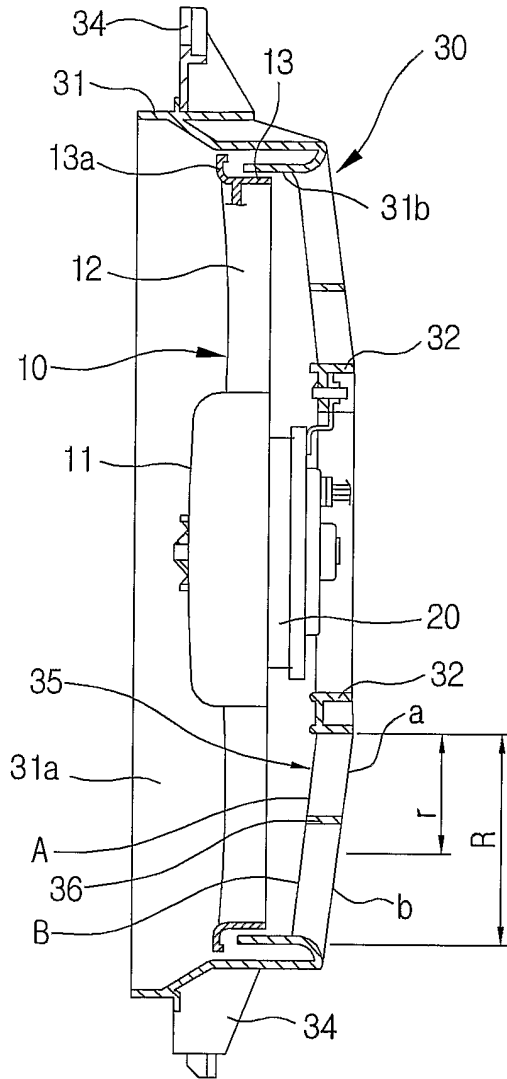

Figure 6

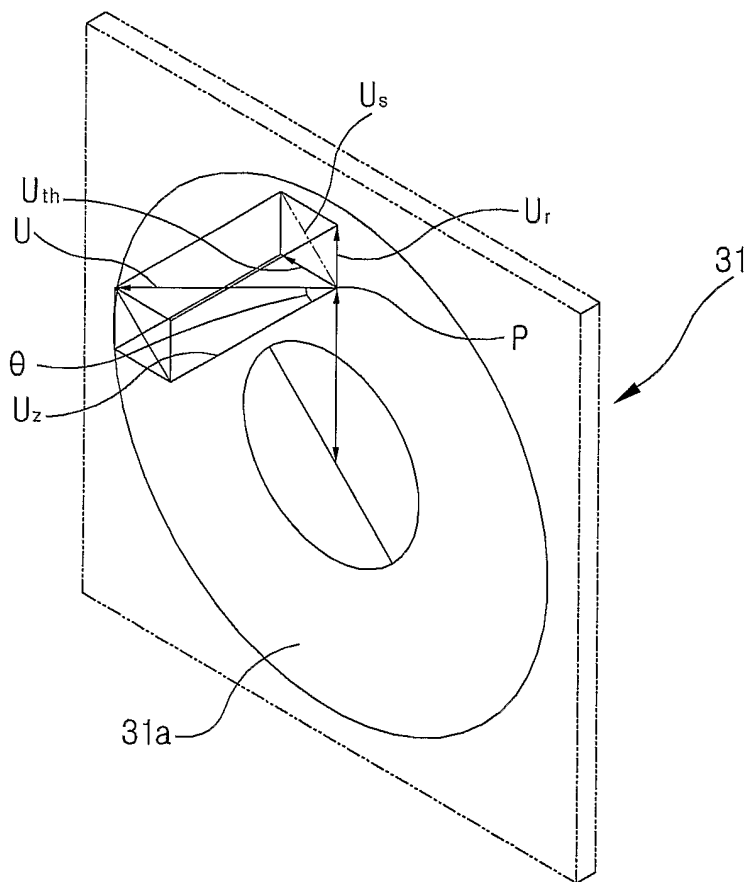

Figure 7

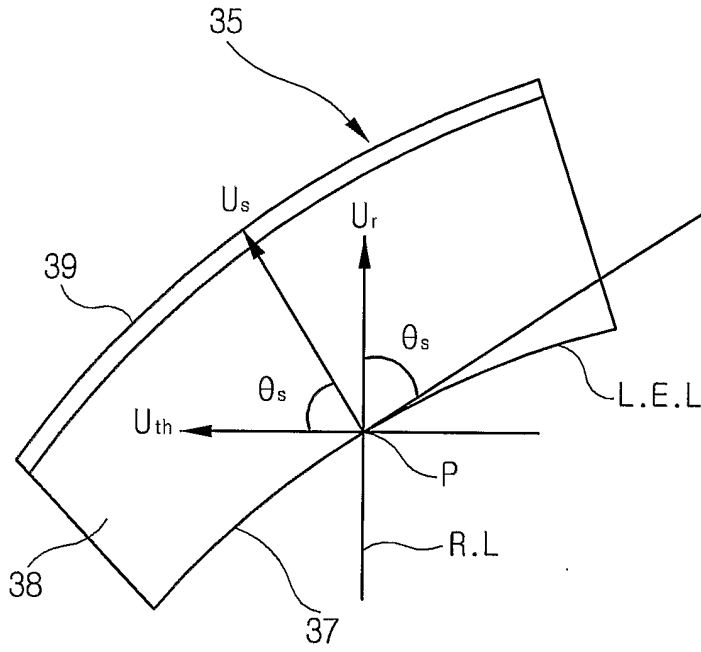

Figure 8

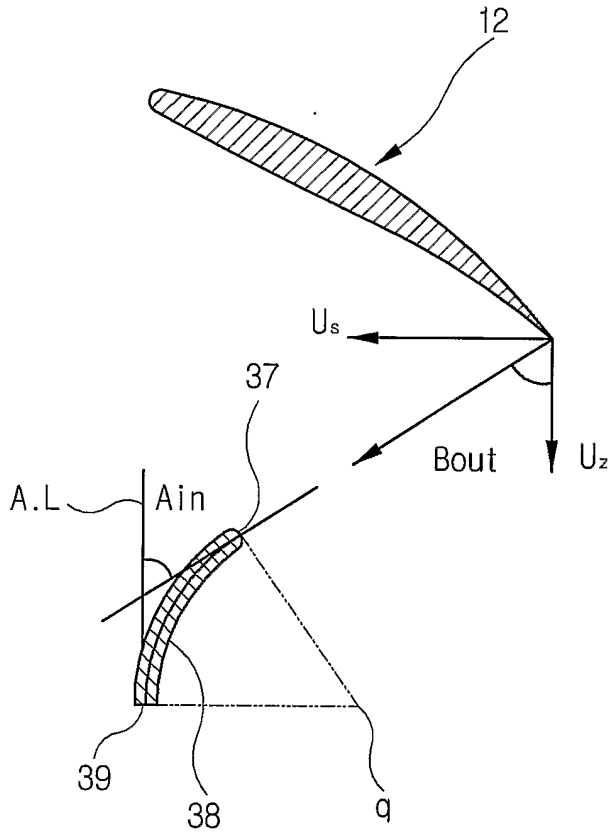

Figure 9

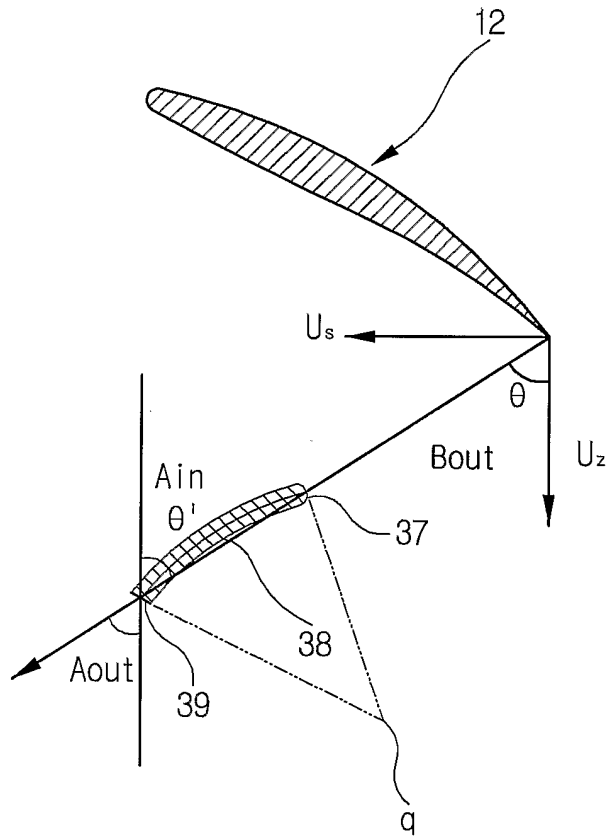
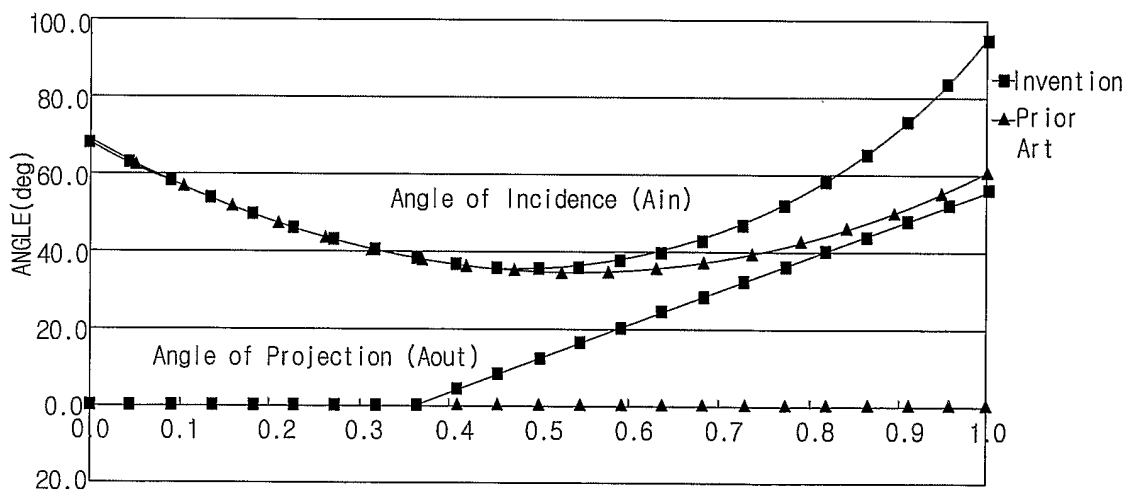

Figure 10



INTERNATIONAL SEARCH REPORT

International application No.
PCT/KR2004/001610

A. CLASSIFICATION OF SUBJECT MATTER

IPC7 F04D 29/54

According to International Patent Classification (IPC) or to both national classification and IPC

B. FIELDS SEARCHED

Minimum documentation searched (classification system followed by classification symbols)

IPC7 F04D. F28F

Documentation searched other than minimum documentation to the extent that such documents are included in the fields searched

KR JP : IPC as above

Electronic data base consulted during the international search (name of data base and, where practicable, search terms used)

C. DOCUMENTS CONSIDERED TO BE RELEVANT

Category*	Citation of document, with indication, where appropriate, of the relevant passages	Relevant to claim No.
A	US 6,398,492 B1 (Halla Climate Control Corp.) 04 JUNE 2002 See the whole document	1-7
A	JP 10-205497 A (Zexel Corp.) 04 AUGUST 1998 See the whole document	1-4
A	US 4,548,548 A (Airflow Research and Manufacturing Corp.) 22 OCTOBER 1985 See the whole document	1
A	JP 02-196197 A (Daikinind Ltd.) 02 AUGUST 1990 See the whole document	1-4

Further documents are listed in the continuation of Box C.

See patent family annex.

* Special categories of cited documents:

- "A" document defining the general state of the art which is not considered to be of particular relevance
- "E" earlier application or patent but published on or after the international filing date
- "L" document which may throw doubts on priority claim(s) or which is cited to establish the publication date of citation or other special reason (as specified)
- "O" document referring to an oral disclosure, use, exhibition or other means
- "P" document published prior to the international filing date but later than the priority date claimed

- "T" later document published after the international filing date or priority date and not in conflict with the application but cited to understand the principle or theory underlying the invention
- "X" document of particular relevance; the claimed invention cannot be considered novel or cannot be considered to involve an inventive step when the document is taken alone
- "Y" document of particular relevance; the claimed invention cannot be considered to involve an inventive step when the document is combined with one or more other such documents, such combination being obvious to a person skilled in the art
- "&" document member of the same patent family

Date of the actual completion of the international search

11 OCTOBER 2004 (11.10.2004)

Date of mailing of the international search report

11 OCTOBER 2004 (11.10.2004)

Name and mailing address of the ISA/KR

 Korean Intellectual Property Office
920 Dunsan-dong, Seo-gu, Daejeon 302-701,
Republic of Korea

Facsimile No. 82-42-472-7140

Authorized officer

PARK, Jong Joo

Telephone No. 82-42-481-5961



INTERNATIONAL SEARCH REPORT

Information on patent family members

International application No.

PCT/KR2004/001610

Patent document cited in search report	Publication date	Patent family member(s)	Publication date
US 6,398,492 B1	04-06-2002	KR 2000047329 A EP 1016790 A2 EP 1016790 A3 JP 2000205194 A2 JP 3385336 B2	25-07-2000 05-07-2000 02-05-2001 25-07-2000 10-03-2003
JP 10-205497 A	04-08-1998	DE 19751042 A1 DE 19751042 G2 US 6024536 A	28-05-1998 25-04-2000 15-02-2000
US 4,548,548 A	22-10-1985	WO 8505408 A1 EP 183787 B1 AT 66284 E DE 3583795 C0 JP 61502267 T2	05-12-1985 14-08-1991 15-08-1991 19-09-1991 09-10-1986
JP 02-196197 A	02-08-1990	NONE	