

FOR THE PURPOSES OF INFORMATION ONLY

Codes used to identify States party to the PCT on the front pages of pamphlets publishing international applications under the PCT.

AT	Austria	FI	Finland	MN	Mongolia
AU	Australia	FR	France	MR	Mauritania
BB	Barbados	GA	Gabon	MW	Malawi
BE	Belgium	GB	United Kingdom	NL	Netherlands
BF	Burkina Faso	GN	Guinea	NO	Norway
BG	Bulgaria	GR	Greece	NZ	New Zealand
BJ	Benin	HU	Hungary	PL	Poland
BR	Brazil	IE	Ireland	PT	Portugal
CA	Canada	IT	Italy	RO	Romania
CF	Central African Republic	JP	Japan	RU	Russian Federation
CG	Congo	KP	Democratic People's Republic of Korea	SD	Sudan
CH	Switzerland	KR	Republic of Korea	SE	Sweden
CI	Côte d'Ivoire	LJ	Liechtenstein	SK	Slovak Republic
CM	Cameroon	LK	Sri Lanka	SN	Senegal
CS	Czechoslovakia	LU	Luxembourg	SU	Soviet Union
CZ	Czech Republic	MC	Monaco	TD	Chad
DE	Germany	MG	Madagascar	TG	Togo
DK	Denmark	MI	Mali	UA	Ukraine
ES	Spain			US	United States of America

HIGH-PERFORMANCE
DYNAMIC MEMORY SYSTEM

FIELD OF THE INVENTION

5 The present invention is related to a memory system, and more particularly to a memory system which can be coupled with different buses to efficiently support both single and multi-processor architectures.

BACKGROUND OF THE INVENTION

10 With the wide use and rapid development of random access memories ("RAM"), especially dynamic random access memories ("DRAM"), the storage capacity of memory devices doubles approximately every two years. In addition, different types of
15 memory devices, such as DRAMS with different storage capacities, are now available in the market. They include DRAMS of sizes 256k x 1, 1M x 1, 4M x 1, 16M x 1, 256k x 4, 1M x 4, 4M x 4, and soon will include wider DRAMS with storage
20 capacity of 256k x 16 and 1M x 16. However, the questions of how to provide a main memory structure which can efficiently support different processor and bus systems, and allow the use of different types of memory devices, have not yet been solved
25 by the prior art. Further, if such a main memory is provided, the next issue is providing a memory controller which can efficiently control the access to such memory in accordance with different processor system requirements.

In order to satisfy different processor system requirements, a variety of different system buses have been introduced having different bandwidths to support different processors. These buses may also have different bus clock frequencies.

One bus available on the market is a bus called M-bus, developed by Sun Microsystems Inc., which is compatible with complementary metal-oxide semiconductor (CMOS) technology. The M-bus is normally classified into two levels. Level 1 supports a single processor system. An example of a uniprocessor system is generally shown in Figure 1A, in which bus 2 is coupled between processor 3 and memory controller 4, the latter connected to memory 5. Another example of a uniprocessor system is shown in Figure 1B, wherein the processor 6 is coupled to a cache 7 which is further coupled to a system bus 8. Level 2 supports multi-processor systems. An example of a multi-processor system 10 is shown in Figure 1C. A plurality of processors 11-12 (only two are shown) share common main memory 17 through bus 15 and memory controller 16, with each processor 11 or 12 is associated with at least one local cache 13 or 14. An example of the level 2 M-Bus is the SPARC M-Bus Level 2 which can support normal read and write transactions plus a number of additional transactions including coherent invalidate transactions, coherent read transactions, coherent write and invalidate transactions, and coherent read and invalidate transactions. Each of these latter transactions requires a local cache be associated with each processor. The system bus may have different bus sizes, such as 32-, 64- and 128-

bit data widths, and different clock frequencies, such as 25 MHz, 33 MHz, 40 MHz, or 50 MHz.

Conventional memory systems are not flexible enough to support a variety of buses which each
5 have different bus sizes and clock rates. In particular, conventional memory systems do not efficiently support bus systems which are coupled to a number of processors, each of which is associated with at least one local cache, and which
10 share a common main memory.

For example, in some processor systems, cache controllers in copyback environments may not have internal buffering allowing them to purge the cache line internally, and then request a read of the
15 main memory (a DRAM), followed by a write of the old cache line back to the main memory. They frequently are required to perform the write to main memory first, followed by the read. This wastes processor cycle time waiting for the missed
20 cache line to be filled. Conventional memory systems have no mechanism to support a cache purge operation. In addition, during a coherent read transaction, conventional memory controllers can only monitor the transaction without being able to
25 convert the inhibited read operation to write operation, thereby implementing a reflective memory.

Some conventional memory controllers are provided with a data buffering member, such as a
30 FIFO, to buffer normal write or read data. However, the configuration of such controllers are generally not suitable for support of the above

mentioned cache purge or reflective read
operations. Further, such controllers cannot
efficiently perform a data transaction between main
memory and the system bus when the data buffering
5 member is occupied by a previous transaction. In
addition, short byte and long burst transactions
normally cannot be performed in an efficient and
reliable manner.

Finally, conventional memory systems are not
10 flexible enough to enhance the timing resolution of
the memory in accordance with different system bus
clock frequencies.

Examples of these conventional memory systems
are disclosed in the following references: U.S.
15 Patent No. 4,954,951 issued on September 4, 1990; a
product specification of Advanced Micro Devices
titled "4M Configurable Dynamic Memory
Controller/Driver", product No. AM29C668, published
in March, 1990; a product specification of SAMSUNG
20 titled "Dynamic RAM Controllers", product
No. KS84C31/32, published in November, 1989; a
product specification of Signetics Fast titled
"Intelligent DRAM Controller", product No. FAST
74F1763, published on March 12, 1989; a product
25 specification of Signetics Fast titled "DRAM and
Interrupt Vector Controller", product No. FAST
74F1761, published on March 5, 1989; and an article
titled "M-Bus Provides Processor - Independent
Bus", published on Microprocessor Report on
30 August 7, 1991.

SUMMARY OF THE INVENTION

Thus, it is an object of the present invention to provide a memory system which has the flexibility for use with different types of system buses which may have different bus sizes and clock frequencies.

It is another object of the present invention to provide a memory system which has a novel memory structure for supporting different processors and bus systems. The memory structure includes a plurality of blocks, each of which can be configured with a different type of memory chip and can have different sizes.

It is yet another object of the present invention to provide a memory system which can efficiently support all M-bus Level 1 and Level 2 transaction types, and cache purge operations along with a coherent read with simultaneous copyback operation.

It is still another object of the present invention to provide a memory system which can support 32-, 64- and 128-bit wide system buses, which includes additional bits for parity generation and checking for data, parity checking on the address, and additional control bits for increased flexibility in supporting multiple processors.

It is still another object of the present invention to provide a memory system which can be coupled with different types of system buses having

different bus clock frequencies and which has enhanced memory timing resolution.

It is still another object of the present invention to provide a memory system which provides a plurality of data channels to allow efficient data transactions.

It is still another object of the present invention to provide a memory system which supports a plurality of blocks in a memory and provides efficient access to one or more banks in one of the blocks depending on bus and data sizes.

It is still further object of the present invention to provide a DRAM controller which can reduce system bus traffic and enhance the efficiency of multiple processors which share a common main memory.

In accordance with the objects of the present invention, a high-performance dynamic memory system is provided having a main memory and a memory controller coupled between a system bus and the main memory.

The main memory includes at least one block which includes a plurality of banks. Each of the banks has a predetermined memory bandwidth. Each block of the main memory is constructed from a DRAM-type memory element.

The system bus can have different bus sizes and different bus frequencies. The system bus is coupled to a plurality of processors, each of which

is associated with at least one local cache so that
the main memory is shared by all the processors.
In a first embodiment of the invention, the system
bus is an extended M-bus which can support
5 different processor systems.

The memory controller includes control
circuitry to receive address and control signals
from the system bus in order to control transfer of
data to and from the system bus, to and from main
10 memory. The controller also includes data sending
and receiving circuitry to send and receive data to
and from the system bus, to and from the main
memory, again under control of the control
circuitry.

15 The control circuitry includes an address
signal path and a control signal path. On the
address signal path, the control circuitry is
provided with a read address path and a write
address path. The write address path is further
20 provided with two write paths. One is used for
providing a path for the first data transaction
address when consecutive write data transactions
occur on the system bus. The other is used for
holding the subsequent data transaction address
25 while the first is completed in the DPAM. On the
control signal path, the control circuitry is
provided with a read control signal path and a
write control signal path. The write control
signal path further includes a first path for a
30 first data transaction control signal and a second
path for holding the subsequent data transaction
control signal.

The control circuitry is configured to provide program information with respect to the structure parameters of main memory, system bus sizes, and system bus frequency multiplication factors, to support different memory types in main memory, different types of system buses which have different bus sizes and bus speeds, and to enhance the timing resolution of main memory.

The data sending and receiving circuitry includes a plurality of data channels, each of which includes a write data path on which there is at least one write first-in-and-first-out member (write FIFO). The write FIFO is to temporarily maintain data received from the system bus to be stored into main memory, and to allow any of the processors to obtain data from the memory at any time without loss of the data previously stored in the FIFOs. Also on the write data path, there is at least one other reflective first-in-and-first-out member (reflective FIFO) to capture data on the system bus which is transferred from a local cache associated with one of the processors, to a local cache of another data requesting processor, such that the data is simultaneously stored in the reflective FIFO and in the local cache of the data requesting processor. Each channel has a predetermined data bus bandwidth which is the same as that of a bank in a block of the main memory.

Each data channel also includes a read data path for transfer of read data between the system bus and main memory. An error detection and correction circuit is provided on the read data path which is used to support correcting data.

In a second embodiment, two data channels are combined into a single data channel unit in the form of an integrated circuit. A data sending and receiving circuit can include two or more of these data channel units.

The control circuitry of the memory controller also includes control logic which can identify and select the proper data channels and channel units. This selection depends on the system bus size, the status of each data channel, and the data sizes to be transferred. During the write of a data burst, the channels in each unit can operate in an alternating fashion, so that more data words within the main memory boundary can be accumulated in the proper channels for efficient transfer into main memory.

In a third embodiment, main memory is structured into plurality of blocks each of which can be configured with a different DRAM type. Each block includes a plurality of banks of an identical DRAM type.

The main memory system also includes a frequency multiplier for multiplying the bus frequency to provide a memory clock for enhancing the main memory timing resolution. The frequency multiplier uses a bus frequency multiplication factor produced by the programmable memory controller.

In a fourth embodiment, the programmable memory controller includes a number of program registers which store programming functions. Among these program registers, there is a command

register which stores a variety of information for control purposes, including programming the number of blocks in main memory, and each block's size and location the processors memory maps, the bus size, the bus frequency multiplication factor and the data bandwidth of the error detection and correction circuit. A timing register is provided to store timing of control signals for the main memory read and write operations with an enhanced timing resolution. The memory controller also includes a status register to store the status of each data channel, such as the status of each FIFO (empty or not empty) on each data channel and the error information occurring during data transactions. There is also a location program register supplied to store location information of the blocks of main memory in overall memory map, which is connected to a comparator to allow correct selection of one of the blocks in the memory when an incoming address matches one of the programmed locations in the location program register. Associated with the location program register, there is a mask register for storing mask bits used to identify which processor's address bits should participate in the address match.

The features and advantages of the present invention, including those mentioned above and others not yet mentioned, will become apparent after studying the following detail description of the embodiments, with reference to the following drawings.

BRIEF DESCRIPTION OF THE DRAWINGS

Figure 1A shows an example of a uniprocessor system.

5 Figure 1B shows another example of a uniprocessor system.

Figure 1C generally shows a multi-processor system in which the cache is used.

10 Figure 2 shows an embodiment of a main memory structure constructed in accordance with the present invention.

Figure 3 shows a block diagram of an embodiment of a control circuit of a memory controller constructed in accordance with the present invention.

15 Figure 4 shows a block diagram of an embodiment of a data sending and receiving circuitry of a memory controller circuitry constructed in accordance with the present invention.

20 Figure 5 shows a block diagram of an embodiment of an error detection and correction device (EDC) used in the data sending and receiving circuitry of the memory controller constructed in accordance with the present invention.

Figure 6A-6E show various embodiments of the data sending and receiving circuitry arrangements for efficiently supporting system buses which have different bus sizes, and data transactions which have different data sizes.

5

DETAILED DESCRIPTION OF THE PREFERRED EMBODIMENTS

The following descriptions are directed to embodiments of a memory system constructed in accordance with the present invention.

5 The memory system includes a DRAM structure and a unique DRAM controller which is suitable for support of a large memory structure and buses having different bus sizes, such as of 32-, 64- or 128-bit data widths, and also having different bus
10. clock frequencies, such as 25Mhz, 33Mhz, 40Mhz or 50Mhz. The memory system is also suitable for support of a number of bus transactions to provide high-performance and high-efficiency memory services to different processor systems. Such
15 processor systems include single processor systems as shown in Figure 1A and 1B, and multi-processor systems as shown in Figure 1C. The DRAM controller includes a DRAM control device (DRAC) and a data sending and receiving device (DSRD). The DRAC is
20 coupled to the DSRD between the system bus and the DRAM. The DSRD is coupled between the system bus and the DRAM. The system bus can be either a single multiplexed address/data bus or contain separate address and data buses. The bus interface
25 is fully synchronous and uses the rising edge of the bus clock. Bus signal definitions are an extension of M-bus standard, so that an M-bus can be used to support additional processor systems.

30 The memory system of the present invention consists of a high-performance address/control path and at least one high performance error detecting and correcting data path. On the address/control

path, the memory controller is provided with a programmable DRAC for efficiently controlling memory accesses for a number of bus systems and data transactions. On the data path, the memory controller is provided with a DSRD which includes FIFO buffers and an error detection and correction mechanism (EDC). The DSRD serves as high-performance data buffers and demultiplexers on writes and as error correctors on reads. The DRAC and DSRD can be respectively made into integrated circuits.

1. MEMORY STRUCTURE

Referring now to Fig. 2, an embodiment of a memory structure constructed in accordance with the present invention is shown. The memory of Fig. 2 is constructed using a plurality of DRAM chips.

The memory of Fig. 2 is organized into 4 blocks (blocks 0-3). Each block consists of 4 banks (banks 0-3). Each bank is 39 bits wide (i.e. 32 data bits and 7 error check bits). Banks 0-3 can be accessed simultaneously as a 156-bit wide block, to achieve maximum memory performance.

The memory has 12 address lines (multiplexed as row and column addresses) connected to the memory side of the memory controller. The memory also has four DRAM Read/Write lines, RW[3-0] (one for each of the 4-39 bit banks in the accessed block), and four each RAS[3:0] and CAS[3:0] control lines connected to the memory side of the memory controller. The memory is written using the early write cycle, i.e. DRAM chips having common I/O will

-15-

be controlled in the same manner as the DRAM chips having separate I/O. External buffers are required to drive the substantial address and control capacitance that exists when using DRAMS in such large configurations.

The memory controller chip set (DSRD and DRAC) is designed to support either 256K X 1 or 4, 1M X 1 or 4, or 4M X 1 or 4 and 16M X 1 DRAM chips. The controller will also support wider 4 Mbit DRAMS (256K X 16) and wider 16 Mbit DRAMS (1M X 16) when these devices become available. The maximum total capacity of the memory system can be extended from four Mbytes using 256K X 1 DRAMS and populating a single block, up to 1 Gbyte using 16M X 1 DRAMS and populating all four blocks. Storage capacity is expandable in binary increments. DRAM chip types remain identical within all four banks comprising a block, however, each block may be populated with a different type of DRAM. The possible configurations of the DRAM structure are given below in Table 1. A multiple frequency clock (2X a 40 or 50 MHz bus clock, 3X a 33 MHz bus clock, or 4X a 25 MHz bus clock) input is provided to control DRAM timing to 10 ns intervals (12.5 ns. for 40 MHz bus clocks).

Each 156-bit block has its data lines connected to the respective data lines of the other blocks. The appropriate block is selected by asserting its RAS and CAS lines. The 156 bits emerging from the selected block will be steered through the DSRD where the data will be checked and corrected if necessary. The error check bits are removed and the data is placed on the bus. The

SUBSTITUTE SHEET

memory can support 32-, 64- or 128-bit wide data paths.

TABLE I

DRAM TYPE	DRAM BANK	DRAM BLOCK	CAPACITY PER BLOCK MBYTES	NUMBER OF BLOCKS	CAPACITY PER SYSTEM MBYTES
256K X 1	256K X 39	4 X 256K	4	1-4	4-6
		X 39			
1M X 1	1M X 39	4 X 1M X	16	1-4	16-4
		39			
4M X 1	4M X 39	4 X 4M X	64	1-4	64-256
		39			
16M X 1	16M X 39	4 X 16M	256	1-4	256-1024
		X 39			
256K X 4	256K X 40	4 X 256K	4	1-4	4-16
		X 39			
1M X 4	1M X 40	4 X 1M X	16	1-4	16-64
		40			
4M X 4	4M X 40	4X 4M X	64	1-4	64-256
		40			

It should be understood that each banks in a block of the main memory can also be configured with other predetermined data width, such as with 64 data bits.

2. BUS STRUCTURE AND DEFINITION

The system bus can comprise different buses, including the M-Bus which is currently available on the market. In accordance with the present invention, the bus signal specification may be reorganized and extended in order to efficiently support multiple processor systems. In one embodiment, a signal specification is provided for support of existing 32-, 64-, and 128-bit data buses, with additional bits for data parity

generation, checking for data, address parity
checking, and control bits for supporting different
processor systems. Separate address and data lines
can be provided to support non-multiplexed system
5 bus applications. The signals can also be
multiplexed to support M-bus compatibility. The
signal specification, in cooperation with the
memory system of the present invention, not only
supports all M-bus Level 1 and Level 2 transaction
10 types including bursts, but also allows premature
termination of burst transactions, provides support
of various burst orders (sequential and Intel style
bursts), provides support of different processor's
burst length requirements (Intel, Motorola, Sparc),
15 and allows write posting of cache data lines into a
FIFO. Additionally, read/write or I/O operations
can be inhibited to allow conversion of data
transactions, such as from read to write or from
write to read, so as to enhance bus transaction
20 speed.

The control signals transferred through the
system bus, as an example, can include address
signals (Ad), address strobe signals (AS*) to
identify the address phase, data strobe signals
25 (DS*) for identifying the data phase, address/data
parity signals (ADP), and data burst last signals
(BLST) for premature termination of bus
transactions. The control signals can further
include interface mode signals (IMD) for
30 identifying bus interface mode, transaction type
signals (TYPE) for specifying transaction type,
transaction size signals (SIZE) for specifying the
number of bytes to be transferred during a bus
transaction, and memory inhibit signals (INH) for

aborting a DRAM read/write or I/O cycle already in progress. Other control signals can include transform cycle signals (TRC) for transforming an inhibited transaction cycle into another, snoop window signals (SNW) for extending the snoop window beyond the timing interval programmed in a timing register, bus acknowledge signals (BACK) for supplying the transaction acknowledge to the bus master, bus error signals (BERR) for indicating a bus error occurrence, and bus request signals (BR) issued by DRAC to hold the bus during reflective read transactions. Still other control signals include bus busy signals (BB) asserted by DRAC for the duration of its bus ownership, bus grant signals (BG), and interrupt out signals (INT) asserted whenever an error condition occurs. Finally, the control signals can include clock signals (CLK) for synchronizing all bus transactions, multiple frequency clock signals (MCLK) for generating an enhanced timing to DRAM, reset-in signals (RSTIN) for resetting DRAM, and identification signals (ID).

The following describes some of these control signals in more detail.

IMD is used to specify the bus type or bus mode which is currently coupled to the main memory system, such as M-bus mode or a generic bus mode.

TYPE specifies the data transaction type during the address phase. The interpretation of the TYPE bits is determined by IMD. For example, when IMD indicates that the bus type is SPARC type, the TYPE bits identify all the data transaction

types of the SPARC M-bus, which include write, read, coherent invalidate, coherent read, coherent write and invalidate, and coherent read and invalidate. When IMD indicates that the bus type is a generic type, the TYPE bits identify various data transaction types of either M-bus or generic applications, which include write, read, read-in-default burst size, write, write-in-default burst size, sequential burst order, non-sequential burst order (such as Intel processors), posted write, posted write in default burst size, position of byte 0 on the bus. Byte 0 appears as either the lowest byte on the bus or as the highest byte on the bus.

SIZE bits are used to specify the transaction size and particular byte or bytes to be enabled. The transaction size may include a byte, a halfword (2 bytes), a word, double words, 16-byte burst, 32-byte burst, 64-byte burst, or a 128-byte burst. The particular byte enable information is added to the original M-bus specification to provide byte enable and misaligned data transfers compatible with processors such as the i486 and 68040. Any combination of byte enables may be asserted simultaneously. Interpretation of transaction size information is a function of a particular one or more bytes' addresses in an address signal, which allows, for example, selection of one or more data channels in the memory controller, or to access one or more bytes in a bank in main memory, or to access one or more banks in main memory.

PMD bits specify the parity computation algorithm and identify those signals that

participate in the parity computation. PMD bits are valid during the entire system bus cycle. The parity modes include parity computation disabled, address parity computed, data parity computed, address and data parity computed, odd parity computed, or even parity computed.

BACK bits supply a transaction acknowledge signal to the master system processor (i.e. the bus master). In the M-bus mode, the acknowledge signal includes M-bus definitions, such as uncorrectable error, valid data transfer, and idle cycle. In the generic mode, the acknowledge signal may include valid data transfer, error exception, and idle cycle.

AS is asserted by the bus master to identify the address phase of the transaction.

DS is asserted by the bus master during the data phase of a transaction. DS is internally pipelined in the DRAC and appears one clock cycle before the clock cycle in which the data is transferred. Data is transferred and BACK is asserted during every system bus cycle after the clock cycle in which DS is asserted (provided that the DRAM controller can acknowledge a transfer). The bus master may use DS to control (suspend) the slave's response on a cycle-by-cycle basis.

BLST is used by the bus master to prematurely terminate bus transactions. BLST is only recognized during clock cycles in which DS is also asserted. Therefore BLST should be asserted one

system bus cycle before the last desired data transfer.

INH is asserted by a cache controller in multi-processing environments to abort a DRAM read/write or register I/O cycle already in progress. When INH is received before the data transfer begins the operation is terminated before any data is transferred. When INH is received after the memory controller has begun to issue bus acknowledges, it is ignored. When the memory is reflective, the read of DRAM is converted into a write. The BACK signal, now originating from the snooping cache that owns the data, is interpreted to provide a write strobe to the FIFO/EDC data path. Inhibited writes may also be converted to reads for ownership.

TRC, when asserted, transforms an inhibited read cycle into a write cycle (reflective) or an inhibited write cycle into a read cycle (read for ownership).

SNW, when asserted, extends the snoop window beyond the interval that results from the values programmed into the DRAM timing register. This signal can be permanently de-asserted if it is not used.

BERR indicates that a bus parity error has occurred during the address or data phase of a data transaction. The signal is asserted asynchronously (i.e. one or more clocks late). This signal is valid one clock cycle after the error occurs and

lasts until cleared. The signal is cleared by writing an appropriate bit to the Command Register.

BR is issued by the DRAC during reflective-read transactions. BR issued by the main memory system is interpreted as the highest priority request for ownership to the system's bus arbitration logic. Additional system bus transactions are suspended until the ongoing write (resulting from the reflective-read) to main memory is complete. The original M-bus specification has no explicit mechanism for a reflective main memory to postpone the next bus transaction while the data being transferred between two caches is simultaneously written to DRAM. Systems having more elaborate protocols for acknowledging data transfers between a requesting cache and a cache data owner can use BR to create a data strobe to prevent the next transaction from overwriting the reflective data path inside the DSRD.

BG is asserted by external arbitration logic in response to a BR to indicate that the DRAC has been granted ownership of the bus.

BB is asserted by the DRAC for the duration of its bus ownership. The DRAC will acquire the bus as it completes the main memory write transaction during reflective read operations.

INT is an open DRAM output which is asserted (if enabled) whenever an error condition occurs. For example, system bus parity errors or memory errors can cause INT to be asserted.

CLK synchronizes all bus data transactions. For example, the maximum clock frequency is 50 Mhz and all data transactions are strobed in at the rising edge of the clock signal.

5 RSTIN is used to reset the DRAC. The signal must be asserted for at least four clocks.

ID bits have two interpretations. When IMD indicates M-Bus mode, ID bits interpretation is strictly M-Bus compatible. In M-Bus mode, the ID
10 field selects various configuration spaces within the M-Bus address space for access to the port register and other I/O registers. When used in non-M-Bus modes, the ID bits are used in conjunction with address signals to define the
15 nature of the bus transaction and select I/O registers or DRAM memory. A match is required between the ID bits and the fixed values for defined generic (non M-Bus) operations.

In a second embodiment, the system bus
20 specification is an extension of the M-bus standard (called EM-Bus) which can support more processor systems including SPARC, i860, i486, and Motorola 68040, 88000 series and MIPS R3000 and R4500 series. In EM-Bus, some of the M-Bus signals are
25 reserved, some of the M-Bus signals are redefined and enhanced, and some new signals are added.

All EM-Bus transactions are split into an address phase followed by a data phase. The address phase is identified by the assertion of the Address Strobe signal (AS*) and lasts for one
30 EM-Bus cycle. The data phase immediately follows the

address phase and may last for one or more clock
cycles. The data phase is identified by the Bus
Master's assertion of Data Strobe (DS*) and
simultaneous de-assertion of AS*. The Bus Master
5 may temporarily interrupt data transactions by de-
asserting DS*. DS* may be permanently asserted for
systems that do not require its use. The EM-Bus
extension allows multiplexed address and data
busses, however they are not mandatory as in M-Bus.
10 When multiplexing to create AD[0:63], as in M-Bus,
the address (and attributes that form AD[36:63])
will be asserted simultaneously with AS* and the
data will be asserted simultaneously with DS*.

EM-Bus signals are summarized in the following Table 2:

TABLE 2

SIGNAL	DESCRIPTION	SOURCE	TYPE	EXT	DRC
A[0:35]	ADDRESS	MASTER	TRI-STATE	R	X
5 AP[0:3]	ADDRESS PARITY	MASTER	TRI-STATE	X	
D[0-63]	DATA	MASTER/SLAVE	TRI-STATE	R	X
D[64-127]	DATA	MASTER/SLAVE	TRI-STATE	X	O
DP[0:15]	DATA PARITY	MASTER/SLAVE	TRI-STATE	X	O
10 TYPE[0:5]	TRANSACTION TYPE	MASTER	TRI-STATE	R	X
SIZE[0:7]	TRANSACTION SIZE	MASTER	TRI-STATE	R	X
C	DATA CACHEABLE	MASTER	TRI-STATE	DM	
LOCK	BUS LOCK INDICATOR	MASTER	TRI-STATE	DM	
MBL	BOOT MODE/LOCAL BUS	MASTER	TRI-STATE	DM	
VA[12:19]	VIRTUAL ADDRESS	MASTER	TRI-STATE	DM	
15 RESERVED	FOR FUTURE EXPANSION	MASTER	TRI-STATE	DM	
SUP	SUPERVISOR ACCESS INDICATOR	MASTER	TRI-STATE	DM	
MID[0:3]	MODULE IDENTIFIER	MASTER	TRI-STATE	DM	
IMD	INTERFACE MODE	MASTER	TRI-STATE	X	X
PMD[0:2]	PARITY MODE	MASTER	TRI-STATE	X	O
20 AS*	ADDRESS STROBE	MASTER	TRI-STATE		X
DS*	DATA STROBE	MASTER	TRI-STATE	X	O
BLST*	BURSTLAST	MASTER	TRI-STATE	X	O
SH*	SHARED	BUS WTCHR	OPENDRAIN		
25 INH*	MEMORY INHIBIT	MASTER	TRI-STATE		O
SNW*	SNOOP WINDOW	BUS WTCHR	TRI-STATE	X	O
TRC*	TRANSFORM CYCLE	MASTER	TRI-STATE	X	O
RSTIN*	RESET IN	RST LOGIC	BI-STATE		X
RSTOUT*	RESET OUT	ANYONE	BI-STATE		
30 BACK[0:2]*	BUS ACKNOWLEDGE	SLAVE	TRI-STATE		X
BERR*	BUS ERROR	ANYONE	OPENDRAIN		O
BR*	BUS REQUEST	MASTER	BI-STATE		O
RG*	BUS GRANT	ARBITER	BI-STATE		O
BB*	BUS BUSY	MASTER	TRI-STATE		O
35 CLK	CLK	CLK BUFFER	BI-STATE		X
IRL[0:3]	INTERRUPT LEVEL	INT LOGIC	BI-STATE		
ID[0:3]	MODULE IDENTIFIER	SYSTEM	BI-STATE		O

The signals marked with an X in the EXT column are present in the EM-Bus specification, but not the M-Bus specification. The signals marked with

an R (Redefined) are described in M-Bus, but redefined and enhanced in this EM-Bus specification. Those signals marked with a DM (De-Multiplexed) have identical functional definitions as in M-Bus, however they need not be multiplexed with the data lines in EM-Bus. The signals marked with an X in the DRC column are all required inputs to the DRAM Controller chip set. Those marked with an O in the DRC column are options that may be required in various subsystems of the memory system.

During the address phase of the transaction, A[0:35] contains the transaction address. This address is valid during the assertion of AS*. In addition, AP[0:3] reflects the parity of the lowest 32 bits of the transaction's address. Parity is not supported for A[33:35]. These parity bits need only be valid during the assertion of AS* and therefore may be multiplexed with the lowest four data parity bits. The parity's sense (i.e. odd/even and enable/disable) is specified by the PARITY MODE bits, PM[0:2]. Parity is assigned as shown in Table 3:

TABLE 3

AP[3]	AP[2]	AP[1]	AP[0]
A[31:24]	A[23:16]	A[15:8]	A[0:7]

During the data phase of the transaction, D[0:63] contains the lowest 64 bits of the transaction. The SIZE bits that specify the individual byte enables are specified as Transaction Attributes. Data is only transferred during the assertion of DS*. D[0:63] may be

multiplexed with the address and transaction signals to maintain compatibility with the original M-Bus definition. The byte ordering convention is defined by the TYPE bits.

5 During the data phase of the transaction, D[64:127] contains the upper 64 data bits of the transaction. The SIZE bits that specify the individual byte enables are again specified as Transaction Attributes, and data is again only
10 transferred during the assertion of DS*. Note that the D[64:127] bits are optional. The byte ordering convention is defined by the TYPE bits.

 During the data phase of the transaction, DP[0:15] specifies the parity of the data bus. The
15 parity's sense (i.e. odd/even and enable/disable) is specified by the PARITY MODE bits, PMD[0:2]. These parity bits need only be valid during the assertion of DS*. DP[0:3] may therefore be multiplexed with AP[0:3]. DP[0:15] are assigned as
20 illustrated in Tables 4 and 5:

TABLE 4

DP[0:7]							
DP[7]	DP[6]	DP[5]	DP[4]	DP[3]	DP[2]	DP[1]	DP[0]
D[63-56]	D[55-48]	D[47-40]	D[39-32]	D[31-24]	D[23-16]	D[15-8]	D[7-0]

25

TABLE 5

DP[8:15]							
DP[15]	DP[14]	DP[13]	DP[12]	DP[11]	DP[10]	DP[9]	DP[8]
D[127-120]	D[119-112]	D[111-104]	D[103-96]	D[95-88]	D[87-80]	D[79-72]	D[71-64]

30 The M-Bus specification identifies a number of transaction attributes that appear as MAD[36:63] during the address phase of every transaction. In

contrast, the EM-Bus extension breaks these transaction attribute signals out separately and specifies them as enhancements. The TYPE and the SIZE definitions are extended to handle processor protocols other than SPARC. For Sparc processors, the TYPE and SIZE bits retain their interpretation as in the M-Bus specification. For Intel or Motorola processors, these bits are redefined to handle the idiosyncracies of their respective bus interfaces.

The interpretation of TYPE and SIZE is specified by the EM-Bus IMD bit. The relationship between the original M-Bus signals AD[0:63], and EM-Bus A[0:35] and transaction attributes are defined in the following Table 6:

TABLE 6

EMBUS SIGNAL	MBUS SIGNAL	SIGNAL DESCRIPTION
A[0:35]	MAD[0:35]	PHYSICAL ADDRESS FOR CURRENT TRANSACTION
TYPE[0:3]	MAD[36:39]	TRANSACTION TYPE
SIZE[0:2]	MAD[40:42]	TRANSACTION SIZE
C	MAD[43]	DATA CACHEABLE (A)
LOCK	MAD[44]	BUS LOCK INDICATOR (A)
MBL	MAD[45]	BOOT MODE/LOCAL BUS (A)(O)
VA[12:19]	MAD[46:53]	VIRTUAL ADDRESS (O) LEVEL 2
RESERVED	MAD[54:58]	RESERVED FOR FUTURE EXPANSION
SUP	MAD[59]	SUPERVISOR ACCESS INDICATOR (A)(O)
MID[0:3]	MAD[60:63]	MODULE IDENTIFIER
TYPE[4:5]		TRANSACTION TYPE (EXTENSION)
SIZE[3:7]		TRANSACTION TYPE (EXTENSION)

All of these transaction attributes are valid while AS* is asserted during the address phase.

The TYPE and SIZE definitions are also extended to handle different processors bus

characteristics. These extended definitions support processor systems including SPARC, i860, i486 and Motorola 68040, 88000 series, and MIPS R3000 and R4000 series.

5 During the address phase, TYPE[5:0] specify the Transaction Type. The interpretation of the TYPE bits (either SPARC M-Bus compatible or generic interface) is determined by the IMD bit, as shown in Tables 7 and 8.

10

TABLE 7

MBUS, IMD = 0

TYPE 5	TYPE 4	TYPE 3	TYPE 2	TYPE 1	TYPE 0	DATA SIZE	TRANSACTION TYPE
0	0	0	0	0	0	ANY	WRITE
0	0	0	0	0	1	ANY	READ
0	0	0	0	1	0	32 BYTES	COHERENT INVALIDATE
0	0	0	0	1	1	32 BYTES	COHERENT READ
0	0	0	1	0	0	ANY	COHERENT WRITE & INVALIDATE
0	0	0	1	0	1	32 BYTES	COHERENT READ & INVALIDATE
0	ALL OTHER COMBINATIONS						RESERVED

15

20

TABLE 8

GENERIC, IMD = 1

TYPE 5	TYPE 4	TYPE 3	TYPE 2	TYPE 1	TYPE 0	DATA SIZE	TRANSACTION TYPE
0	0	X	X	X	0	ANY	WRITE
0	X	X	X	X	1	ANY	READ
1	0	X	X	X	0	DEFAULT BRST	WRITE
1	X	X	X	X	1	DEFAULT BRST	READ
0	X	X	X	0	X	--BUS WIDTH	SEQUENTIAL BURST ORDER
0	X	X	X	1	X	--BUS WIDTH	INTEL BURST ORDER
0	X	X	0	X	X	ANY	SIZE[2:0] ARE SIZE BITS
0	X	X	1	X	X	--BUS WIDTH	SIZE[7:0] ARE BYTE ENABLES
0	X	0	X	X	X	ANY	LITTLE ENDIAN BUS
0	X	1	X	X	X	ANY	BIG ENDIAN BUS
0	1	X	X	X	0	ANY	POSTED WRITE
1	1	X	X	X	1	DEFAULT BRST	POSTED WRITE

25

30

35

The functions of each bit of TYPE[5:0] in the generic mode (IMD = 1) are explained in the following:

TYPE[0] identifies READ and WRITE. When 0
5 this bit indicates the transaction is a read. When
1 this bit indicates the transaction is a write.

TYPE[1] identifies the BURST ORDER, such as
sequential or non-sequential burst. When TYPE[1]=0
the burst order is sequential. When TYPE[1]=1 the
10 burst order is non-sequential. Given a system bus
of width N bytes (N=4, 8 or 16), any transaction of
SIZE S>N constitutes a burst (where $S=kN$, $k=2^i$, i an
integer=>1, and $Nk \leq 128$ bytes).

TYPE[2] bits have two alternative
15 interpretations. When TYPE[2]=0, the transaction
length in bytes is given by the value of SIZE[2:0].
When TYPE[2]=1, the byte(s) that are enabled in the
transaction are specified when their respective
size bits are asserted low (e.g. SIZE[N]* means
20 BYTE[N] participates in the transaction). For
elaboration see the SIZE[7:0] definition.

TYPE[3] specifies LITTLE ENDIAN AND BIG
ENDIAN. Processors may define the position of BYTE
0 on the bus in either of two ways. Either BYTE 0
25 appears as the lowest byte on the bus (D[7:0] -
little endian, TYPE[3]=0) or BYTE 0 appears as the
highest byte on the bus (big endian - D[M:M-7],
where $M = B_w - 1$, B_w is the bus width bits,
TYPE[3]=1). For elaboration see the definition of
30 the SIZE[7:0] bits.

TYPE[4] relates to WRITE POSTING. When TYPE[4]=1, the write data is posted into the write fifo, where it remains until the next read is completed. This can be used to postpone the actual dram write until after the dram read is completed, thereby speeding cache line fills.

TYPE[5] specifies DEFAULT BURST MODE. When TYPE[5]=0, the transaction's size is specified by the SIZE[7:0] (which are interpreted according to TYPE[2]). When TYPE[5]=1, the transaction's size is specified by the default burst size programmed into the command register.

SIZE[7:0] are provided to tell the memory system the data TRANSACTION SIZE. During the address phase, SIZE[2:0] specify the number of bytes to be transferred during a bus transaction. SIZE[7:3] was added to the original MBus specification to offer byte enabled and misaligned data transfers compatible with the i486 and 68040 processors. The interpretation of SIZE is determined by TYPE[2] as shown in Tables 9-13:

TABLE 9

SIZE INTERPRETATION WITH TYPE[2]=0, SIZE[7:3]=XXXX

SIZE 3	SIZE 2	SIZE 1	SIZE 0	TRANSACTION SIZE
0	0	0	0	BYTE
0	0	0	1	HALF-WORD (2 - BYTES)
0	0	1	0	WORD (4 - BYTES)
0	0	1	1	DOUBLE WORD (8 - BYTES)
0	1	0	0	16 BYTE BURST
0	1	0	1	32 BYTE BURST
0	1	1	0	64 BYTE BURST
0	1	1	1	128 BYTE BURST

TABLE 10

SIZE INTERPRETATION WITH TYPE[2]=1

SIZE 7	SIZE 6	SIZE 5	SIZE 4	SIZE 3	SIZE 2	SIZE 1	SIZE 0	TRANSACTION	TRANSACTION
(BY7*)	(BY6*)	(BY5*)	(BY4*)	(BY3*)	(BY2*)	(BY1*)	(BY0*)	BIG ENDIAN	LITTLE ENDIAN
X	X	X	X	X	X	X	0	BYTE D[63:54]	BYTE D[7:0]
X	X	X	X	X	X	0	X	BYTE D[55:48]	BYTE D[15:8]
X	X	X	X	X	0	X	X	BYTE D[47:40]	BYTE D[31:24]
X	X	X	X	0	X	X	X	BYTE D[39:32]	BYTE D[31:24]
X	X	X	0	X	X	X	X	BYTE D[31:24]	BYTE D[39:32]
X	X	0	X	X	X	X	X	BYTE D[23:16]	BYTE D[47:40]
X	0	X	X	X	X	X	X	BYTE D[15:8]	BYTE D[55:48]
0	X	X	X	X	X	X	X	BYTE D[7:0]	BYTE D[63:54]

Any combination of Byte Enables may be asserted simultaneously. Processors generally require their byte enable signals to be contiguous. No checking is performed to distinguish invalid combinations from valid combinations.

TABLE 11

SIZE INTERPRETATION WITH TYPE[2]=0 AS FUNCTION OF ADDRESSES
32, 64 & 128 BIT SYSTEM BUS SIZES, TYPE[3]=0 (LITTLE ENDIAN), SIZE[7:3]=X

5	SIZ[2:0]=0	SIZ[2:0]=0	SIZ[2:0]=0	SIZ[2:0]=0	SIZ[2:0]=0	SIZ[2:0]=0	SIZ[2:0]=0	
	A[2:0]=111	A[2:0]=110	A[2:0]=101	A[2:0]=100	A[2:0]=011	A[2:0]=010	A[2:0]=001	
	AD[63:56]	AD[55:48]	AD[47:40]	AD[39:32]	AD[31:24]	AD[23:16]	AD[15:8]	
	BYTE 7	BYTE 6	BYTE 5	BYTE 4	BYTE 3	BYTE 2	BYTE 1	
	SIZ[2:0]=001		SIZ[2:0]=001		SIZ[2:0]=001		SIZ[2:0]=001	
	A[2:0]=11X		A[2:0]=10X		A[2:0]=01X		A[2:0]=00X	
10	HALFWORD 3		HALFWORD 2		HALFWORD 1		HALFWORD 0	
	SIZ[2:0]=010				SIZ[2:0]=010			
	A[2:0]=1XX				A[2:0]=0XX			
	WORD 1				WORD 0			

TABLE 12

SIZE INTERPRETATION WITH TYPE[2]=0 AS FUNCTION OF ADDRESSES
32 BIT SYSTEM BUS SIZES, TYPE[3]=1 (BIG ENDIAN), SIZE[7:4]=X

15	SIZ[2:0]=0	SIZ[2:0]=0	SIZ[2:0]=0	SIZ[2:0]=0
	A[1:0]=00	A[1:0]=01	A[1:0]=10	A[1:0]=11
	AD[31:24]	AD[23:16]	AD[15:8]	AD[7:0]
20	BYTE 0	BYTE 1	BYTE 2	BYTE 3
	SIZ[2:0]=001		SIZ[2:0]=001	
	A[1:0]=00X		A[2:0]=01X	
	HALFWORD 0		HALFWORD 1	
25	SIZ[2:0]=010			
	A[2:0]=0XX			
	WORD 0			

TABLE 13

SIZE INTERPRETATION WITH TYPE[2]=0 AS FUNCTION OF ADDRESSES
64 & 128 BIT SYSTEM BUS SIZES, TYPE[3]=1 (BIG ENDIAN), SIZE[7:3]=X

30	SIZ[2:0]=0	SIZ[2:0]=0	SIZ[2:0]=0	SIZ[2:0]=0	SIZ[2:0]=0	SIZ[2:0]=0	SIZ[2:0]=0	
	A[2:0]=000	A[2:0]=011	A[2:0]=010	A[2:0]=011	A[2:0]=100	A[2:0]=101	A[2:0]=110	
	AD[63:56]	AD[55:48]	AD[47:40]	AD[39:32]	AD[31:24]	AD[23:16]	AD[15:8]	
	BYTE 0	BYTE 1	BYTE 2	BYTE 3	BYTE 4	BYTE 5	BYTE 6	
	SIZ[2:0]=001		SIZ[2:0]=001		SIZ[2:0]=001		SIZ[2:0]=001	
35	A[2:0]=00X		A[2:0]=01X		A[2:0]=10X		A[2:0]=11X	
	HALFWORD 0		HALFWORD 1		HALFWORD 2		HALFWORD 3	
	SIZ[2:0]=010				SIZ[2:0]=010			
	A[2:0]=0XX				A[2:0]=1XX			
	WORD 0				WORD 1			

ID[3:0]. The ID bits identification have two interpretations. When IMD=0 the ID interpretation is strictly M-Bus compatible, as shown in Table 14. Then the ID field selects various configuration spaces within the M-Bus address space for access to the Port Register and other I/O registers. When used in non-M-Bus applications (IMD=1), the ID bits are used in conjunction with address signals to define the nature of the bus transaction and select I/O registers or dram memory. A match is required between ID[3:0] and the fixed values shown in the Table 15 for the defined generic (non M-Bus) operations.

TABLE 14

15 ID[3:0] WHEN IMD=0, MBUS APPLICATIONS

MBUS CONFIGURATION SPACE	ID[3:0]
F/F000/0000(h) to F/F0FF/FFFF(h)	0(h) reserved for boot prom
F/F100/0000(h) to F/F1FF/FFFF(h)	1(h)
• •	•
F/Fn00/0000(h) to F/Fn00/0000(h)	n(H)
• •	.
F/FE00/0000(h) to F/FEFF/FFFF(h)	E(h)
F/FF00/0000(h) to F/FFFF/FFFF(h)	F(h)

20

TABLE 15

25 ID[3:0] WHEN IMD=1, GENERIC APPLICATIONS

ID[3]	ID[2]	ID[1]	ID[0]	DRAM MODULE SELECTION
M/IO*=0	D/C*=0	X	X	NOT SELECTED
M/IO*=0	D/C*=1	1	0	INDIRECT ADDRESS REGISTER
M/IO*=0	D/C*=1	0	1	I/O REGISTERS
M/IO*=1	D/C*=X	X	X	MEMORY

30

The Parity Mode bits PMD[0:2] specify the parity computation algorithm and identify those signals that participate in the parity computation.

They are valid during the entire system bus cycle.
 These bits are defined as shown in Table 16:

TABLE 16

	PM[2]	PM[1]	PM[0]	PARITY MODE
5	X	0	0	PARITY COMPUTATION DISABLED
	X	0	1	ADDRESS PARITY COMPUTED
	X	1	0	DATA PARITY COMPUTED
	X	1	1	ADDRESS & DATA PARITY COMPUTED
	0	X	X	ODD PARITY COMPUTED
10	1	X	X	EVEN PARITY COMPUTED

DS* is asserted by the bus master during the data phase of the transaction. Data is transferred and BACK[0:2]* is valid during every cycle that DS* is asserted. The master can use DS* to control (slow) the slave's response on a cycle-by-cycle basis. Note that M-Bus does not have a DS* signal.

The default burst length is specified by SIZE[0:3] during the address phase of every transaction. BLST* may be used by the bus master to override the default burst length, prematurely terminating bus transactions during the cycle asserted. BLST* is only recognized during cycles in which DS* is also asserted.

DRPA* is provided by the bus master to indicate that the next main memory access will occur within the same DRAM page as the previous access. The main memory subsystem can use this signal to avoid an unnecessary RAS precharge to the DRAM array. This signal is only used in a single processor system.

BACK[0:2]* are identical to MRDY*, MRTY* and MERR* in M-Bus. The following Tables 17 and 18 summarize their function:

TABLE 17

5

When IMD = 0

BACK[2] (MERR*)	BACK[1] (MRDY*)	BACK[0] (MRTY*)	DEFINITION
0	0	0	RETRY
0	0	1	ERROR3 - UNCORRECTABLE
10 0	1	0	ERROR2 - TIMEOUT
0	1	1	ERROR1 - BUS ERROR
1	0	0	UNDEFINED (L1) OR RESERVED (L2)
1	0	1	VALID DATA TRANSFER
1	1	0	RELINQUISH AND RETRY
15 1	1	1	IDLE CYCLE

TABLE 18

20

WHEN IMD=1

BACK[2] ERR*	BACK[1] ACK*	BACK[0] RTY*	DRC DEFINITION	GENERIC DEFINITION
1	0	1	VALID DATA TRANSFER	VALID DATA TRANSFER
0	0	1	UNCORRECTABLE	ERROR EXCEPTION
1	1	1	IDLE CYCLE	IDLE CYCLE

3. DRAC STRUCTURE

25

30

An embodiment of a DRAM control device (DRAC) 50, constructed in accordance with the invention, is shown in Fig. 3. Recall that all bus transactions are divided into an address/control phase followed by a data phase. During the address/control phase specified by AS*, the control signals are routed over the system bus into DRAC 50 through a control input buffer 52 and stored in a pipeline register 53. In addition, address signals AD [35:0] and address parity signals ADP [3:0] are

routed into DRAC 50 from the system bus through address and address parity input buffer 91 and are synchronously clocked into pipeline register 92.

Also during the address/control phase, address
5 signals AD[35:0] contain the transaction address.
This address remains valid during the assertion of
AS*. The address parity is checked by address
parity check circuit 95 after the address enters
DRAC 50. A single parity bit is computed for each
10 byte of the address signal and checked against the
four address parity bits of the address parity
signal ADP [3:0]. ADP[3:0] reflects the parity of
the lowest 32 bits of the transaction address. The
address parity may be optionally multiplexed with
15 the data parity. Address parity is not supported
for bits [35:33] in the AD[35:0]. The parity's
sense (i.e. odd/even and enable/disable) is
specified by PMD. The nature of the parity
computation is specified every bus cycle by PMD.

20 When an address parity error occurs, the
transaction is terminated and bus error signal BERR
is asserted. An address bus parity error bit is
set in a status register 76 in DRAC 50. BERR also
indicates the bus parity error condition during the
25 data phase of a transaction. This signal is
asserted asynchronously (i.e. one or more clocks
late), and is valid one clock after the error
occurs and lasts until cleared. The signal is
cleared by writing the appropriate bit in command
30 register 73 in DRAC 50.

All synchronous inputs from the system bus are
assumed to be valid at the rising edge of the

clock. Some of the synchronous control inputs are rendered valid by the assertion of AS* during the address phase of a bus cycle. These latter control inputs include the signal IMD for identifying the bus type, the signal TYPE for specifying data transaction type, and the signal SIZE for specifying data transaction size.

In accordance with the present invention, the address path and control path of DRAC 50 are respectively split so that cache purge operations can be supported. The address path includes a read address path for read transaction (including all standard M-bus read transactions), and a write address path. The write address path further includes a first path for the first of two consecutive write transaction addresses, and a second path for the second of two consecutive write transaction addresses which follow the first write transaction. A write address register 112 is provided in the second path to hold the second address signal. It should be mentioned that processors normally have no mechanism to hold data transaction address until the address is acknowledged. The configuration of the DRAC 50 of the present invention allows more efficient data transactions. The control path includes a read control signal path for normal and reflective- read control signals, and a write control signal path. The write control signal path is also provided, with a first path for the first of two consecutive write control signals and a second path for the second of two consecutive write control signals which are associated with a second transaction immediately following a first write transaction. A

write control register 62 is provided in the second path to hold the second control signal.

Multiplexers 63 and 113 are used respectively to select write address/control signals from the normal write and posted-write address/control signals. The selected write control signals and write address signals are respectively sent to write control register 65 and write burst counter 114. The read control signals and the read address signals are respectively stored in read control register 64 and read burst counter 116. The contents of write and read control registers 64 and 65 are selected by control source multiplexer 68 along with a refresh control signal from refresh control circuit 85. The selected signal from control source multiplexer 68 is then sent to status and timing control logic 72. The address from the uppermost portions of read and write address burst counters 114 and 116 are multiplexed, by address source multiplexer 121, with the address from a refresh address counter in refresh circuit 85. The address for the DRAM operation will originate from one of these three sources. The particular source is determined by status and timing control logic 72. Write address burst counter 114 supplies the address during writes, read modify writes (that are writes of byte(s) less than a word), inhibited DRAM writes, and posted writes that allow a conversion from normal writes to reads for ownership cycles. Read address burst counter 116 supplies the address during normal read and reflective-read, the latter being a conversion from a normal read to a coherent read with a synchronous write of the read data into main memory.

When a read is occurring and a posted write signal was asserted on the previous write operation, the contents of address pipeline register 92 are compared by comparator 108 with the posted write address in write address register 112. If the two addresses match, the posted write precedes the read operation. Otherwise, the incoming read occurs immediately with the posted write occurring after the read is completed. The lowest seven bits of the address bus are excluded from the comparison. Therefore, a posted write's burst address span can overlap (or contain or be contained within) the read's burst address span while still maintaining coherency in DRAM 50.

The output of address multiplexer 121 flows into row/column multiplexer 125 which includes a row/column pre-multiplexer and row/column address multiplexer. In the row/column pre-multiplexer the address signal is divided into a row address and column address, depending on the size of the DRAM chips in the accessed block of the DRAM structure which is selected by address block comparator 105. The divided address then flows into row/column address multiplexer 125 which creates the actual address for the DRAM under control of RAS/CAS generation circuit 87.

Write and read address counters 114 and 116 are each split into two overlapping portions. The lower portion of each counter controls the burst over the system bus. The upper portion of each counter controls the burst into main memory. Further, the upper and lower portions of each counter overlap at address bits 2 and 3, with these

bits used to identify the channels in the DSRD to that specify the selected bank or banks within the memory by the DRAC 50. The interpretation of the counter's address outputs depends on the system bus size such as 32-, 64- or 128-bits and the EDC's width in the DSRD such as 32- or 64-bits and the data transaction size information.

The definition of a burst-type transaction is as follows. Given a system bus of width N bytes ($N=4, 8$ or 16), any transaction of SIZE $S > N$ constitutes a burst (where $S=kN$, $k=2^i$, i an integer $\Rightarrow 1$, and $Nk \leq 128$ bytes). During bursts the lowest $\log_2 N$ bits of the address, $A[\log_2 N - 1 : 0]$, bus are fixed at 0 (the alignment constraint). The next $\log_2 k$ bits, $A[(\log_2 k + \log_2 N - 1) : (\log_2 N)]$ form the burst counter for the transaction. When the TYPE bits indicate that the burst order is sequential, subsequent addresses are generated by sequentially incrementing these $\log_2 k$ bits of the address. After reaching the address in which all $\log_2 k$ bits are 1's the counter wraps around to 0, where all $\log_2 k$ bits are low. High-order addresses $A[35 : \log_2 k + \log_2 N]$ remain fixed.

When $TYPE[1] = 1$ the burst counter increments in the non-sequential fashion characteristic of Intel processors. The lowest $\log_2 N$ bits are again fixed at 0 (the alignment constraint). The next $\log_2 k$ bits, $A[(\log_2 k + \log_2 N - 1) : (\log_2 N)]$ form the burst counter for the transaction. These bits are incremented in the following fashion:

-42-

	An+2	An+1	An
	An+2	An+1	An*
	An+2	An+1*	An
	An+2	An+1*	An*
5	An+2*	An+1	An
	An+2*	An+1	An*
	An+2*	An+1*	An
	An+2*	An+1*	An*

10 In the embodiment of the EMBus in accordance with the present invention, TYPE[1] identifies the burst order, i.e. sequential or non-sequential.

15 When a system burst occurs the data transfer begins at the programmed address. During normal operation, subsequent addresses will be generated by incrementing the system bus burst counter modulo the burst length. The counter's address will wrap around when it reaches the highest value for a given programmed burst length. Bursts must terminate after the programmed burst length or may
20 terminate early with the assertion of BLST. Burst addresses are not always incremented sequentially.

25 The Intel 486 processor requires a special burst order for addressing. This order is supported by specifying the Intel burst mode. Even during bursts using Intel's non-sequential order, the counter will not increment outside of the address boundary specified by the burst length. System burst read and write transfers occur on
30 N bit aligned boundaries for systems using bus widths of N bits (N=32, 64, or 128).

An inhibited line is provided to instruct the DRAC 50 to abort an ongoing read request which

allows reflective-read transactions and coherent read transactions. This signal is asserted by the owner of the cache block in a multi-processing environment, so that it can supply data to the requesting cache while main memory access is inhibited. This input can also be used in multi-processing environments to convert inhibited DRAM read operations to write operations, thereby implementing a reflective memory. When a snooping cache determines that it owns the valid copy of the data, it supplies that data over the bus to the requesting cache. The main memory is updated simultaneously.

When a processor attempts to write data in a multi-processing environment, its local cache must determine the status (cacheable or write-through, hit or miss) of the data line in question. When the write operation occurs to a line that is cacheable, a hit may occur in a second snooping cache that has previously modified the same line and contains the only valid copy. The DRAM controller inhibits the ongoing write operation when the snooping cache supplies data to the requesting cache. When a valid copy of the data is not present in a snooping cache, the write operation into DRAM can be inhibited and converted to a read operation at the same address.

During read or write operations, the snoop window is extended until CAS is asserted. These time intervals are programmable in conjunction with all the other DRAM timings. Alternatively, an external input is provided to extend the window

until all other devices on the system bus have completed their snoop cycles.

Memory refresh requirements vary depending on the density and organization of the memory chips comprising main memory. However, rows must
5 refreshed at the same time interval (in this case a read operation followed by scrubbing). All banks of a given block are scrubbed simultaneously at a particular address.

10 Status and timing control logic 72 includes a bus status circuit which produces bus transaction type identification signals (FET) to the data sending and receiving device (DSRD), and a memory status circuit to produce memory cycle identifica-
15 tion signals (FEDRT) to DSRD.

In accordance with the present invention, the timing control logic 72 includes several programmable registers which are used to program system set-up and status information to support
20 different system requirements. The following tables are provided to better understand these programmable registers. In the tables, the first row lists the bit number. The second row lists the name of the bit. The third row gives the values assigned to the bit after system reset is asserted.
25 The fourth row lists the lowest 4 nibbles of the register byte's address. The highest addresses will depend on the interface mode specified by IMD. All values listed are given in binary or hex (h).
30 All signals are active high.

Each register (except M-Bus specific port registers) is spaced 16 bytes apart in the address space so that its contents will be accessible on the lowest 8 bits of the data bus regardless of system bus width.

Programmable (read and write) command register 73 includes four bytes, for example, which are respectively defined in Tables 19-22.

TABLE 19

10	CR7	CR[6:0]
	CIE	RFD[5:0]
	0	3F(h)
Address 0000(h)		

RFD[6:0] is a Refresh Counter Divisor. These bits divide CLK down to 1 Mhz.

CIE is a Coherent Invalidate Acknowledge Enable. When this bit is set high it enables M-Bus to Coherent Invalidate cycles. BACK is generated 2 clocks after the address phase in which the Type bits specify this cycle. Systems requiring different acknowledge delays should set CIE=0 and use an external PLD to generate the acknowledge.

TABLE 20

25	CR[15]	CR[14]	CR[13:12]	CR11	CR[10:9]	CR8
	SPARE	INIT	SBS	ES	BLKS[1:0]	IE
	0	0	00	0	00	0
Address 0010(h)						

IE enables the interrupts to the system bus.

BLKS[1:0] defines the number of blocks in binary. The value in binary is one less than the number of blocks, e.g. 0(h)=1 blocks, 3(h)=4 blocks.

5 ES specifies the number of data bits in each EDC packet, or EDC size. 0 specifies 32 Bits, while 1 specifies 64 Bits.

SBS specifies the number of data bits in the system bus, or alternatively, the system bus size. 00 specifies 32 Bits, while 01 specifies 64 Bits. 10 Likewise, 10 specifies 128 Bits.

INIT triggers an initialization of the DRAM memory and its check bits.

TABLE 21

15	CR[23:20]	CR[19:18]	CR[17:16]
	SPARE	PLL[1:0]	DFB[1:0]
	0	0	0
Address 0020(h)			

20 DFB[1:0] indicates the default burst length for cache line read/writes. These bits are defined in a similar way to the input SIZE bits. The bus executes burst transactions with this default length when the appropriate TYPE bit is asserted during the address phase of a transaction. They are interpreted as follows:

25 DFB[1:0] Default Brust Length

00	16 Bytes
01	32 Bytes
10	64 Bytes
11	128 Bytes

PLL[1:0] programs the multiplication factor from the incoming bus clock (CLK) to MCLK. The PLL bits are defined as follows:

	PLL[1:0]	MCLK
5	00	UNUSED
	01	X2 (40 or 50 MHz bus clock)
	10	X3 (33 MHz bus clock)
	11	X4 (25 MHz bus clock)

The multiple frequency clock input is provided by a bus frequency multiplication circuit to set the memory timing to 10 ns (except 12.5 ns for 40 MHz bus) regardless of system bus clock frequency. This result is achieved by the use of programmable timing register 74. The bus frequency multiplication circuit can be a phase locked loop (PLL) circuit which is preferably incorporated inside the memory controller chip (not shown). Under this arrangement, the memory timing is controlled internally, not externally.

20 TABLE 22

CR31	CR30	CR29	CR28	CR27	CR26	CR25	CR24
CBERR	EDC	EDBP	EABP	ESEW	EMEW	ERMW	ETME
0	0	0	0	0	0	0	0
Address 0020(h)							

25 ETME Enables the interrupt indicating that the error log FIFO in the DSRD is full.

ERMW Enables the interrupt indicating that a multiple error has occurred on a Read-Modify-Write Cycle.

EMEW Enables the interrupt indicating two or more errors in a single word.

ESEW Enables the interrupt indicating that a single correctable error has occurred in a single word.

5 EABP Enables the interrupt indicating that one of the address bytes has a parity error.

EDBP Enables the interrupt indicating that one of the data bytes has a parity error.

10 EDC Enables the correction of single bit errors in the data path.

CBERR Clears the condition asserting BERR on the system bus.

15 Programmable (read and write) DRAM timing register 74 includes eight bytes, for example, which store the timing of various control signals for DRAM operations under enhanced timing resolution. These timing signals are defined in tables 23 and 24.

TABLE 23

20

DT3[7:0]		DT2[7:0]		DT1[7:0]		DT0[7:0]	
tRIN	tDC	tCP	tRPR	tCPW	tMAC	tRAM	tAR
F(h)	F(h)	F(h)	F(h)	F(h)	F(h)	F(h)	F(h)
Address 00F0(h)		Address 00E0(h)		Address 00D0(h)		Address 00C0(h)	

TABLE 24

25

DT3[7:0]		DT2[7:0]		DT1[7:0]		DT0[7:0]	
SPARE	SPARE	SPARE	SPARE	SPARE	SPARE	SPARE	tENR
F(h)	F(h)	F(h)	F(h)	F(h)	F(h)	F(h)	F(h)
Address 00F0(h)		Address 00E0(h)		Address 00D0(h)		Address 00C0(h)	

All timing values are set with 4-bit values. The time intervals are specified to 10 ns. accuracy when MCLK is running at 100 Mhz (12.5 ns for 40 MHz bus clock). All timings may be resolved to 1/n of tP, where n is the PLL multiplier (e.g. 50 MHz systems having a PLL multiplier of 2 with tP = 20 ns can have DRAM timing resolutions defined to 10 ns). Therefore, unless the timing values are constrained, the DRAM read data could arrive at the DSRD on a 10 ns boundary rather than a 20 ns boundary of the bus clock.

The following defines the programmable time intervals that are available.

'AR programs the time interval between start of address signal and RAS assertion.

'RAM programs the time interval between start of RAS and the multiplexed address.

'MAC programs the time interval between start of the multiplexed address and CAS assertion.

'CPW programs the CAS pulse width.

'RPR programs the RAS precharge width.

'CP programs the CAS precharge width.

'DC programs the FIFO data delay to CAS assertion.

'RIN programs the RAS completion during non-reflective Inhibit.

'ENR programs the Enable delay of FESTRB on read.

'ACC programs the DRAM access time (determined by DRAM chips).

5 'CLZ programs the DRAM CAS to Output Low Z
(determined by DRAM chips).

'P programs the Bus CLK period.

10 DRAC 50 of the present invention is also provided with programmable (read and write) block placement register 102 which includes eight bytes, for example, for storing locations of the blocks of the DRAM in the overall memory map and population code or size of each block of the DRAM. The arrangement of block placement register 102 is defined in Table 25.

TABLE 25

B3PR[15:0]		B2PR[15:0]		B1PR[15:0]		B0PR[15:0]	
P3[1:0]	BA3[35:22]	P2[1:0]	BA2[35:22]	P1[1:0]	BA1[35:22]	P0[1:0]	BA0[35:22]
0(h)	0(h)	0(h)	0(h)	0(h)	0(h)	0(h)	0(h)
Address	Address	Address	Address	Address	Address	Address	Address
170(h)	160(h)	150(h)	140(h)	130(h)	120(h)	110(h)	100(h)

5
 10
 BA(N) [35:22] indicates Block N Location (0<=N<=3), which specifies the location of Block N of the Memory in the overall memory map. Block N is selected when the incoming address bits A[35:22] match the BA(N) [35:22] bits. Any bits in the BA(N) field can be masked and therefore not considered in the comparison. Comparisons do not begin until the Init Bit is set in the Command Register.

15
 P(N) [1:0] indicates Population Code (0<=N<=3), which specifies the DRAM chip size installed in all banks of Block N. The population codes are defined as follows:

- 00 256K depth (i.e. 256K x 1 or 256K x 4)
- 20 01 1M depth (i.e. 1M x 1 or 1M x 4)
- 10 4M depth (i.e. 4M x 1 or 4M x 4)
- 11 16M depth (i.e. 16M x 1)

Programmable (read and write) block mask register 104 is associated with block placement register 102, which includes eight bytes. Block mask register 104 is used, for example, for masking certain bit(s) in block placement register 102. The masked bits in the register 102 will not be considered in a memory map address comparison. The arrangement of register 104 is shown in Table 26.

TABLE 26

B3MR[15:0]		B2MR[15:0]		B1MR[15:0]		B0MR[15:0]	
SPARE	BM3[35:22]	SPARE	BM2[35:22]	SPARE	BM1[35:22]	SPARE	BM0[35:22]
0(h)	0(h)	0(h)	0(h)	0(h)	0(h)	0(h)	0(h)
Address	Address	Address	Address	Address	Address	Address	Address
1F0(h)	1E0(h)	1D0(h)	1C0(h)	1B0(h)	1A0(h)	190(h)	180(h)

BM(N) [35:22] means Block N Mask ($0 \leq N \leq 3$), which indicates whether a particular bit in the Block Placement Register is considered during memory map address comparison. Summarizing the mask definition:

BM(N) [X] = 0:Ignore Bit X when comparing AD[35:22] against BA(N) [35:22].
 BM(N) [X] = 1:Include Bit X when comparing AD[35:22] against BA(N) [35:22].

Address block comparator 105 is coupled with pipeline register 92 and block placement register 102 for comparing an incoming system bus address with the locations of the 4 blocks stored in placement register 102. When a match occurs the incoming address is transferred to write address register 112 (which holds the address when the write FIFOS in the DSRD are occupied from a previous transfer, or during posted writes), or to read or write burst address counters 114 and 116 under control of status and timing control logic 72.

In accordance with the present invention, DRAC 50 is also provided with status register 76 to store status information from DSRD. For example, this information includes the status of write and read FIFOS and the status of errors happening during operations. Status register 76 allows status and timing control logic 72 to select proper channels and set interruptions of the system in an efficient manner.

DRAC 50 may further include two or more read-only error log FIFO and check bits registers (inside FEDC), each of which can have four bytes for respectively storing syndrome bits reflecting EDC syndrome bits on an error condition, syndrome FIFO empty flag bits, and check bits reflecting the EDC check bits that were present during the previous read operation.

DRAC 50 may also be provided with an M-Bus port register (not shown) for storing vendor codes for M-Bus compatible devices, revision levels for

M-Bus compatible devices, and device number specifying a vendor specific M-Bus device present at this port. DRAC 50 may further be provided with an indirect address register for storing the addresses of other registers inside DRAC 50, and an error location register for storing the address of the most recent error.

Asynchronous inputs RSTIN are used to reset or initialize DRAC 50 after initial power up. RSTIN signals are asserted for at least four clock cycles. After RSTIN is asserted, all bits in command register 73 and status register 76 are initialized to predetermined values. After RSTIN is deasserted, the host programs command register 73 with correct values of the system and set initialization bit (INIT). RSTIN is synchronized to the CLK inside DRAC 50 and the DSRD. The memory controller will respond by clearing the entire DRAM and appropriately initializing the EDC bits in the DSRD.

Non-multiplexed system busses interface to DRAC 50 with address lines only. The control and status registers inside DRAC 50 must be accessible via the system's data bus. An additional eight-bit data path is provided between the FEDCs and DRAC 50 to facilitate programming DRAC 50 control registers and reading status. All I/O transactions occur through the FEDC into DRAC 50 on a byte wide basis.

The following three signals are used to control the system bus, preventing FIFO overflow, while reflective memory operations are being completed. The DRAM controller requests the bus by

asserting BR one clock cycle after receiving an inhibit in reflective memory systems. The system arbitration logic asserts BG, granting the use of the bus to the main memory controller which, in
5 turn, responds with BB indicating a bus busy condition as soon as the current bus master releases its hold on BB. BR is given the highest priority by the arbitration logic in an M-Bus reflective memory system.

10 Other systems may implement reflective memories using alternative protocols. Many arbitrate the next system bus operation while the present operation is being executed (overlapping arbitration). Reflective memory systems must not
15 begin overlapping arbitration cycles until one clock after inhibits occur, to allow time for the DRAM controller to respond with BR.

DRAC 50 uses the information in the programmable registers and in other related
20 registers, and information from the system bus and DSRD's status information, to provide various control signals to its internal circuits and the DSRD. This allows DRAC 50 to efficiently support a particular system bus and processor system, and to
25 provide support for different data transaction requirements. Control signals to DSRD and status responses from the DSRD pass through a DSRD interface and an I/O buffer circuit 128. These signals will be discussed below.

30 The DRAM control signals include RAS[3:0], CAS[3:0], and WR[3:0]. RAS[N] and CAS[N] are externally buffered and connected to all DRAM

memory banks contained in Block [N]. Each of the write enable lines WR[M] are externally buffered and connected to Bank [M] in every occupied block.

5 The particular control architecture employed treats bit wide organized DRAMS and nibble-wide organized DRAMS identically. When bit-wide DRAMS are used, the data in and data out pins are tied together. When nibble-wide DRAMS are used their OE pins are always tied to ground (enabled). Both
10 types of DRAMS are then written using the Early Write Cycle mode. This mode requires their R/W lines to be set at the appropriate levels before assertion of CAS.

15 The occurrence of the RAS and CAS signals with respect to the address, as well as their pulse widths (including precharge widths), can be programmed by setting the appropriate bits in a DRAM Timing Control Register. When MCLK runs at
20 100 Mhz these values can be programmed to a resolution of 10 ns.

The RAS/CAS signals, and the address signals of the DRAC, are respectively sent into the RAS/CAS drivers and address drivers. The RAS[3:0] and CAS[3:0] are generated by RAS/CAS generation
25 circuit 87 and comprise the memory's RAS and CAS timing pulses for all blocks. RAS[N] and CAS[N] are wired to all banks within Block N. The address signals can be formed into 12-bit multiplexed row/column address for the memory which can span 16
30 Mbits of the memory.

4. FEDC UNIT STRUCTURE

In accordance with the present invention, the data sending and receiving device (DSRD) of the memory controller preferably includes a plurality
5 of data channels, each of which is a FIFO/error detection and correction circuit (FEDC 30).

Fig. 4 shows an embodiment of FEDC unit 30, constructed in accordance with the invention, which is part of the memory controller. FEDC unit 30
10 includes two groups of FIFO/error detection and correction logic arrays (FEDCs) to provide two 32-bit data channels. Two of these units can efficiently support either 32-bit or 64-bit system buses. FEDC 30 provides a read and a write data
15 path. In this embodiment, FEDC 30 has a 32-bit data bus interfacing to the system bus and a 64-bit data bus which is subdivided into two complete 32-bit data paths interfacing to the DRAM. Each 32-bit data bus on the DRAM side is associated with
20 seven error check bits. In accordance with the present invention, four FEDC units 30 can be connected to efficiently support 32-, 64- and 128-bit system buses.

FEDC unit 30 is coupled to DRAC 50 through
25 control buffers 175 and output buffer 162 to receive control signals from DRAC 50, and to send status signals back to DRAC 50. FEDC unit 30 is also coupled between a system bus and the DRAM
memory through input and output buffer arrays 130,
30 162, 168, 169, 170, 172, and 174, to send and receive data to and from the system bus, to and from the DRAM under control of DRAC 50.

All data flow between the DSRD and the system data bus is assumed to be aligned with the bus width. When a system bus transaction crosses these aligned boundaries, the processor or cache
5 controller will split the transaction into multiple operations and issue an address phase for each portion. Thus, these misaligned transactions cannot be bursts.

The memory controller stores data into memory
10 on a predetermined memory boundary, depending on the memory structure. In the present embodiment, the memory alignment is 128-bits wide. Burst transactions of 4, 8, or 16 bytes are assumed to be aligned on a 16-byte boundary. In this case, the
15 memory boundary is 128-bit wide data. Burst transactions mis-aligned to the storage boundary will involve 4-, 8-, or 12-byte transfers between the DSRD and main memory during the first cycle of the burst. The memory address will be wrap around
20 within the burst length as more data is transferred. The final data transfer will include the banks omitted during the first cycle of the memory transfer. The nature of the misalignment depends on the defined burst order, such as
25 sequential or Intel.

In accordance with the present invention, FEDC unit 30 includes two groups of FEDC arrays which form two independent data write and read channels. Each channel has 32-bit data width and can access
30 one bank in the memory. The two channels or FEDCs in a FEDC unit 30 can access two banks simultaneously. All write data is steered to one of the two channels. The data path through one of

the two channels is selected during the data phase by the control signals from DRAC 50, depending on the bus size and/or status of the two channels. During a burst write, the two channels can run in an alternating fashion so that all data can be accumulated for transfer into the DRAM.

Each FEDC or data channel includes a write first-in-and-first-out buffer (write FIFO) 145 or 147 for use during normal write transactions. As an advantage of the present invention, write FIFO 145 or 147 is also used for posted write transactions in which the data to be stored is posted in write FIFO 145 or 147. This function is achieved due to the split configuration of the address/control path in DRAC 50.

Each FEDC is further provided with reflective read first-in-and-first-out member (reflective FIFO) 146 or 148 for exclusive use during reflective read transactions, in which a coherent read and a copyback for updating the main memory occur simultaneously. Each FIFO can have a 32-byte depth to support data bursts in different lengths. Bus burst operations are supported up to the full write FIFO depth. Under this configuration FEDC unit 30, in cooperation with split configuration of the address/control paths of DRAC 50 as discussed above, allows posted write transactions, reflective read transactions, and supports various M-Bus Level 1 and Level 2 transaction types.

To abort a write and convert the write to a read for ownership operation in multiprocessing environments, write FIFO 145 and 147 is cleared to

prepare for the next write cycle. DRAC 50 issues a special command to FEDC device 30 to clear FIFO 145 and 147 when writes are inhibited.

5 Certain control signals are also stored in
FIFOs 145-148. These signals include parity
status, bank write status and burst last status.
During writes, these status bits and the FIFO sta-
tus (FIFO empty) are reported by FEDC unit 30
10 through output buffer 162 to DRAC 50 during every
data phase clock cycle. DRAC 50 uses this status
information to complete the write transaction.

During write transactions, system bus data is
stored in system bus pipeline register circuit 136
inside FEDC unit 30 before being transferred into
15 the appropriate write FIFOs. Byte wide parity is
computed on the data by parity checking logic 140
as it flows from register circuit 136 into the
FIFO. This is optionally checked against the bus
parity which is applied simultaneously with data
20 over the system bus into FEDC unit 30 through input
and output buffer 174. A bus parity mode signal
(PMD) is supplied from the system bus to determine
the parity mode. The parity computation is
qualified by the system bus byte enables. If a
25 data bus parity error occurs, a bus error signal
(BERR) is asserted.

The data from FIFOs 145-147 or 146-148 and
output register circuit 193, and all zeros used to
initialize the memory check bits, flow into data
30 multiplexer circuit 156 or 157 which and are
multiplexed under control of DRAC 50. The selected
data signals flow into write polynomial generation

circuits (WPG) 164 or 166 which generate seven additional bits for use by the error correction circuitry. If each FEDC or channel is arranged to handle 32-bit wide data, the width of a single word emerging from a channel through input and output buffers 168-169 or 170-172 will be 39 bits.

The FEDC unit 30, in accordance with the present invention, can support various data transactions having different data lengths, which include byte transactions which are less than the data bit width of a bank of the memory. Also included are multiple word transactions within the memory boundary (sub-burst transaction which are less than the data width of a block of the memory), multiple word transactions which are the same as the data bit width of a block of the memory, and multiple word transactions which exceed the data bit width of a block of the memory.

Byte enable signals from control signal buffer 175 are respectively sent to registers 149-152. These enable signals are then sent to multiplexer circuit 156 and 157 for byte(s) selection.

During a write having less than the data width of a bank in a block of the memory, DRAC 50 executes a read-modified write cycle. The data is first read from a bank of the memory through input and output buffer 168 or 170 and pipelined through pipeline register circuit 179 or 180. Then, the read-out data passes through error detection and correction circuit (EDC) 185 or 188 into data out register circuit 193 or 194. EDCs 185 or 188 detect and correct the errors of the read-out data.

- 62 -

during the read modified-write cycle. The data bytes to be stored, which are buffered in a write or reflective FIFO, are combined with the old read-out data from register circuit 193 or 194 under control of the byte select signals in data multiplexer circuit 156 or 157. The combined write data then flows into write polynomial generation circuit (WPG) 164 which generates new check bits. The modified single word is finally written into the memory under control of appropriate control signals from DRAC 50. Whenever an error occurs in the read-out data, the detected error information will be saved in a read error log FIFO (log FIFO) 200 or 201. The error information can be used to determine which bit was defective.

During writes of a data sub-burst, the data passes into FEDC unit 30 where WPG 164 or 166 appends check bits to the data. A single block in the memory is created, however, not all of the extra long word is written. Only the write strobes and data output enables for the words in the original sub-burst are asserted. CAS is asserted for the selected entire block. The data is written into the appropriate portions of the selected block using an early write cycle. The portions of main memory block that are not updated (write is not asserted) undergo a dummy read operation. This dummy data is discarded.

For a burst of length equal to the block data bit width, the data words are sequentially pipelined over the data bus and demultiplexed by FEDC unit 30. All write strobes are asserted

SUBSTITUTE SHEET

simultaneously updating all bits in a block bandwidth with an early write cycle.

When the burst length exceeds the memory boundary, the accessed block's RAS[x] is maintained low and sequential reassertions of CAS[x] occur writing multiple memory pages (in other words, a page mode-type access occur). In this transaction, the address may be misaligned to the memory page boundary. When this occurs, data appearing simultaneously at write FIFO 145-148 may not be destined for the same memory page. Write strobes emanating from FEDC unit 30 are associated with each bank. The write strobes and FIFO status are selectively enabled, and the write FIFO selectively unclocked, by control signals originating inside DRAC 50. This essentially realigns the central portion of long bursts to a memory data boundary. The final memory page's write strobes, FIFO status and FIFO unclocks are also selectively enabled, completing the storage of the remainder of misaligned data into main memory. If a FIFO empty condition occurs in the middle of a burst write, DRAC 50 waits for more FIFO data to finish the burst into main memory. When DRAC 50 receives a burst-last indication, the transaction is immediately terminated after completing the current cycle, regardless of the burst length that was specified by the SIZE bits during the address phase.

Should a system bus data parity error occur in the middle of a burst, any data inside write FIFO 145-148 from portions of burst transfer that preceded the parity error will be stored in main

memory. The data containing the parity error is ignored on a block basis. In other words, whenever one or more bytes within a block contains a parity error, the entire word with the block width is discarded. After discarding the word that contains a parity error, FIFOs 145-158 may still contain valid data from the portion of the burst transaction that occurred subsequent to the discarded block. This remaining data is stored successfully. An interrupt will be generated and the appropriate status bit set (assuming that data parity error interrupts are enabled) indicating that a parity error has propagated through write FIFOs 145 148. This error will already have resulted previously during a BERR assertion.

During read operations, all bits of the accessed block are read simultaneously. All the bits are strobed in parallel into data pipeline register circuits 179 and 180. The data in the two channels simultaneously flows through EDCs 185 and 188 for error detection and correction, and to data out register circuits 193 and 194. The corrected or uncorrected data in each channel are selected by respective multiplexers 195 and 196. The appropriate data is then selected by data out multiplexer circuit 206 and supplied to the system bus via input and output buffer 130. Byte-wide parity is appended to the data by parity generation circuit 176 as it exits FEDC unit 30 through input and output buffer 174. Under normal conditions, the data will not require correction and is presented via data out multiplexer 206 to the system bus. When the data requires correction, the system bus acknowledge, along with all remaining

data in the burst, is delayed by one clock cycle. Even when multiple words within a burst contain a single bit error, incorrect data will not reach the system bus.

5 The misalignment of a read data burst exceeding a main memory data boundary is fully supported as in writes. Such misaligned transactions will begin with a full memory block read. Only a fraction of that block will be sent
10 over the data bus. The memory access will continue with one or more additional complete blocks being transferred over the system bus. The final access of the burst will return to the original block where one or more untransferred data banks remain.
15 When the burst line length exceeds the bandwidth of main memory, the DRAC 50 maintains the selected block's RAS[x] and reasserts CAS[x] to read the next block (a page mode-type access occurs).

20 Whenever an error occurs during system access or scrubbing, the detected error information will be saved in read error log FIFOs 200 and 201. The error information can be used to determine which bit was defective. Error log FIFOs 200 and 201 are designed to store the results of the longest burst
25 transfers defined for the bus. Error log FIFOs 200 and 201 can fill up due to consecutive errors in the longest defined bus burst. When this occurs, further errors will not be logged. Error log FIFOs 200 and 201 are only intended to capture errors
30 from a single burst. Prior to the next burst, they should be cleared by the host processor.

Status multiplexer 160 is provided to multiplex the status bits from the write and reflective read FIFOS and from error detection circuit 186. The multiplexed signals will be sent to DRAC 50 through output buffer 162.

Fig. 5 shows an embodiment of an EDC circuit 185 or 188. EDC 185 or 188 includes read polynomial generator (RPG) 220 used to catch the read-out data and produce check bits. Syndrome generator 222 compares the check bits from main memory and RPG 220. If the two check bits are identical, no errors have occurred in the data. Should the comparison shows a difference in the two check signals, error detector 224 decodes the syndrome, identifying the type of error. The appropriate error status bits are reported to DRAC 50. An interrupt is also generated to the processor. Simultaneously, error position decoder 226 receives the signal from the syndrome generator to create a 32 bit word that identifies the bit position of the error in response to decoded signal from error detector 226. Inside error corrector 228, these decoded 32-bits are exclusive-OR'd with 32-bit data which does not come through the EDC to, invert the defective bit position. When an error occurs, the error information from the syndrome generator is sent to error log FIFO's 200 or 201.

In accordance with the present invention, FEDC unit 30 can be made into an integrated circuit (IC). Multiple IC's can be arranged in parallel to form a FEDC device or DSRD to support system buses having a wide bus bandwidth and with narrower bandwidth.

It should be understood that the particular configuration of two channels in FEDC unit 30 is only an example to show the present invention's principles. FEDC unit 30 may also be constructed
5 in only one channel or multiple channels. In addition, each channel in FEDC unit 30 may also have a different data bit handling ability, as discussed below.

5. COMBINATION OF FEDC UNITS

10 One important feature of the present invention is that the DSRD of the memory controller includes a plurality of FEDC units 30 or data channels which can be easily set up to efficiently support different bus sizes and processor systems and
15 efficiently utilize memory sources. This is achieved by combining two or more FEDC unit 30 chips to form an FEDC device.

During the address phase, DRAC 50 interprets the address/control information and selects the
20 appropriate channel and FIFOs inside each FEDC unit 30 during every cycle of the data phase. Channel selection depends on the length of the burst, the burst order, and the system bus size. When a write transaction is a data burst, the channels in each
25 FEDC unit 30 are clocked in an alternating fashion. That is, one channel inside each FEDC unit 30 is selected on the first cycle of the data phase and the other channel is selected on the next cycle of the data phase. This process continues
30 demultiplexing and storing data from the incoming system bus until 128 data bits are accumulated or the burst is terminated. This data is then

transferred to DRAM 50. When the INH signal is asserted in a reflective memory, the data is routed into the appropriate reflective FIFOs.

5 During a system bus read transaction, 4 x 32 bits of data and 4 x 7 check bits (156 bits in all) are read in parallel from DRAM 50. Each channel handles 32 bits of data.

10 Figs. 6A and 6B show an embodiment of FEDC device 31 which can efficiently support 32- or a 64-bit system buses. FEDC device 31 includes two FEDC units 32 and 33, each of which have two FEDC channels 34-35 and 36-37. Each channel can handle 32-bit data and can access one bank in a selected block 12 of main memory 10. An example of the
15 connection from FEDC device 31 to blocks 1-4 of main memory is illustrated.

20 A portion of an address signal from write and read burst counters 114 and 116 is used to identify an FEDC unit and channel number, to allow the data to access the proper bank or banks in data transactions which have different data lengths. DRAC 50 provides selection signals to select the proper FEDC units and proper FEDC channels. The lower bits A[3:0] in the address signal and their
25 identification functions for a 32-bit system bus and a 64-bit system bus are, respectively, listed in Tables 28 and 29.

TABLE 28

DRAM BRST	DRAM ADDRESS	BANK#			
ADDRESS	A[27:4]	A3	A2	A1	A0
BUS BRST		CH#	FEDC	BYTE	

5

TABLE 29

DRAM BRST	DRAM ADDRESS	BANK#			
ADDRESS	A[27:4]	A3	A2	A1	A0
BUS BRST		CH#	FEDC(A2) BYTE		
			(A[2:0])		

For 32- and 64-bit system buses, A2=0 identifies FEDC unit 32 and A2=1 identifies FEDC unit 33. A3=0 identifies channels 34 and 36, and A3=1 identifies channels 35 and 37. In a 32-bit bus system, during system bus transactions of 32 bits or larger, A[1:0] will be ignored to allow all bytes to be enabled. In a 64-bit bus system, during system bus transactions of 64 or larger, A[2:0] is ignored and all bytes are enabled.

Figure 6C shows FEDC device 38 which includes four FEDC units 39-42 to support a 128 bit system bus. Each FEDC unit can handle 32 bits of data. Identification functions of A[3:0] are listed in Table 30.

TABLE 30

DRAM BRST	DRAM ADDRESS	BANK#			
ADDRESS	A[27:4]	A3	A2	A1	A0
BUS BRST		FEDC	BYTE		
		PAIR			

25

In this embodiment, combination of A2 and A3 is used to select one of FEDC units 39-42. A3=0 and A2=0 identifies FEDC unit 39. A3=0 and A2=1

identifies FEDC unit 40. A3=1 and A2=0 identifies
FEDC unit 41. A3=1 and A2=1 identifies FEDC unit
42. During system bus transactions of 128 bits or
larger, A[3:0] is ignored and all bytes are
5 enabled.

Figures 6D and 6E show another embodiment of
an FEDC device 43 which includes two FEDC units 44
and 45 to support a 64- or 128-bit system or
smaller system buses. In this embodiment, each
10 FEDC unit 44 or 45 includes only one FEDC or one
FEDC channel which can handle 64 bit data. A3=0
identifies FEDC unit 44, while A3=1 identifies FEDC
unit 45. For a 64 bit system as shown in Figure
6D, during system transactions of 64 bits or larger
15 A[2:0] is ignored, and all bytes are enabled. For
a 128 bit system bus as shown in Figure 6E, during
system transactions of 128 bits or larger A[3:0] is
ignored, and all bytes are enabled.

6. MULTI-PROCESSING SUPPORT

20 The DRAM Controller has complete support for
multi-processing environments. Read operations are
inhibited by the assertion of INH when a snooping
cache supplies data to a requesting cache. When
the TRC input is asserted, these reads are
25 considered reflective and the data transferred over
the bus is captured by the Reflective Write FIFO.
The incoming BACK signal will be used by DRAC 50 to
create FEDS for the FEDC to strobe data into the
Reflective Write FIFO. The BR signal will be
30 asserted by the DRAM controller until the data is
written into the DRAM. This signal can be used to
disable further reads (which could be reflective

until the Reflective Write FIFO is empty). This disabling could occur in one of two ways. Either the BR signal could make the highest priority request of the multi-processing bus arbitration logic keep other hosts off the bus until the transfer is completed, or the snooping cache might have a mechanism to slow down bus transfers (e.g. its own data strobe).

During write cycles the INH signal can be used to abort writes by changing them to a read for ownership. When no snooping cache reports a hit on the requested line, the system will assert TRC and the DRAM will convert the aborted write to a read.

The DRAM controller architecture requires that all processors in a multi-processor system have the same status on a cache line stored in main memory. No provision is made to merge data that results from a write through operation (non-cacheable) from processor A, with a modified line (cacheable) from snooping processor B's cache.

INH and TRC arrive at the DRAM controller before data is transferred to/from memory if the transfer is to be successfully inhibited. The positions of the data strobe controlling the memory transfer can be programmed along with the rest of the DRAM timings. Alternatively the transfer can be positioned by extending the SNW input (snoop window). Systems not requiring a snoop window can permanently de-assert the SNW signal.

7. COOPERATION BETWEEN DRAC and FEDC DEVICE

During a data transaction, DRAC 50, and especially the status and timing control logic 72 of DRAC 50, generates a number of control signals to FEDC 30. These control signals are discussed in the following paragraphs.

After recognizing a memory operation during the address phase of a transaction, DRAC 50 interprets the command and forwards control information to FEDC 30. During the data phase, these control signals are updated by DRAC 50 and FEDC 30 responds with a status signal to DRAC 50 which, in turn, responds over the system bus with a composite acknowledge signal.

For example, the control signals generated by DRAC 50 include FIFO transaction strobe signals (FEDS), FEDC address or chip selection signals (FECS) which select one or more FEDCs for participation in the operation, and FEDC address signals (FEA) for selecting one of the two FEDCs in a FEDC unit or I/O path. Additional signals include FEDC transaction type signals (FET), FEDC byte enable signals (FEBE), and DRAM cycle type signals (FEDRT). Finally, DRAC 50 generates long burst strobe enable signals (FESTEN), FEDC read strobe signals (FESTRB), and I/O data enable signals (IODTA).

FEDS serves as the data strobe during all transactions into FEDC's FIFOs.

FECS is used to select and enable individual FEDC units. It selects one or more FEDCs for participation in a data transaction.

5 FEA is used with FET to define the particular bus transaction. During memory accesses, FEA selects an FEDC within each FEDC unit. On memory writes, FEA selects the appropriate channel or channels depending on the data length and the bus size. On memory reads FEA enables the correct data
10 word onto the system bus.

For example, during write of a long burst, FEA selects one channel in each FEDC unit to accumulate the burst data on a memory boundary, and then selects the other channel in each unit to
15 accumulate the following burst data. The channels in each FEDC unit run in an alternating fashion so that burst data can be efficiently stored into memory.

FET specifies the nature of the transaction in
20 conjunction with FEA. For example, during DRAM read/write operations, FET defines bus transaction types which may include read data, write data, reflective write, clear write FIFOs. During system bus I/O operations, FET bits are used to control
25 the I/O data path from DRAC 50 to FEDC 30. These bits also control reading of I/O registers in DRAC 50, and reading of syndrome and check bits in FEDC 30, along with the reading of M-Bus port registers in FEDC 30.

30 FEBE bits are interpreted as versions of the transaction size. FEBE bits are distributed among

the multiple FEDCs, and reflect the individual bus byte enables in SIZE and along with the transaction's length. These signals are decoded so that they are identical to the SIZE bits.

5 FEDCT is used to identify the appropriate memory cycles which include write EDC check bits, write with EDC, INIT DRAM and check bits, reflective write with EDC, read uncorrected path read corrected path read syndrome FIFOs.

10 FESTEN bits are used to support memory burst transfers that cross 128-bit boundaries. This signal is used to qualify FESTRB and to validate the status bits returned by the memory on a 32-bit basis.

15 FESTRB acts as the read data strobe during memory read operations and the FIFO unlock signal during memory write operations. It is used to store data in FEDC read data pipeline registers 177-180. During writes this signal is asserted by
20 DRAC 50 to access the next data from the appropriate write FIFO.

IODTA bits carry the data between FEDC 30 and the registers inside DRAC 50. They are only used during I/O operations. During memory operations
25 they are disabled.

FEDC unit 30 also generates signals (FEST) back to DRAC 50 to inform it of the status of transactions. Each FEDC unit 30 contributes certain bits to DRAC 50. All FEDC units have their
30 respective FEST signals interconnected at the DRAC

inputs. In an embodiment, the status information includes uncorrectable data error (UNC), two bit data error (DBIT), single bit data error (SBIT), syndrome FIFO empty (EFE), and syndrome FIFO full (EFF). Additional signals include current FIFO data being the last transfer in a prematurely terminated burst (BLST), data parity error (DPE), data FIFO channel 0 being now empty (DFE0), data FIFO channel 1 being now empty (DFE1), reflective data FIFO channel 0 being now empty (RFE0), reflective data FIFO channel 1 being empty (RFE1). These signals are associated with the different memory cycles.

8. REFRESH OPERATION

Refresh requirements vary depending on the density and organization of the DRAM chips in the system. However, rows must be refreshed (in this case a read operation followed by scrubbing) at the same time interval (approximately every 16 μ s). The refresh requests are generated by two cascaded counters (timers) which are a part of refresh circuit 83 of DRAC 50. A programmable 7-bit counter divides CLK down to create a 1 MHz clock signal. This clock is further divided by a 4 bit, modulo 15 counter, to generate a refresh request every 15 usec. These refresh requests are synchronously arbitrated with memory requests by a refresh status control circuit in refresh circuit 83. System bus requests will receive priority over a refresh request, however, the refresh will be inserted before another bus request can occur.

A Refresh/Initialization Address Counter is a part of refresh circuit 83 of DRAC 50, which is connected to address source multiplexer 121. This counter is advanced by one row every refresh request. The column address forms the next most significant portion of the refresh address. After all rows are refreshed and scrubbed at the same column address, the column count advances and all rows are then refreshed at the next column address. The row and column address counters are each 12 bits long spanning 16 Mbits.

All four banks of a given block are scrubbed simultaneously at a particular address. The four error correction channels in FEDC 50 are used in parallel. While one of the four DRAM blocks is scrubbed, the other 3 blocks undergo normal refresh. The 2-bit Scrub Block Counter advances after all rows and columns in a particular block are refreshed so that the next block can be scrubbed. When an error is detected during scrubbing, the correction address will be copied from the Refresh Address Counter to the Error Location Register. During read operations data is always corrected at the system bus (providing EDC is enabled). When an error occurs the corrected data is not written back into the memory array. Data is corrected inside the DRAMs during scrubbing cycles only. When an error occurs during a refresh cycle (i.e. a read to check for errors) is turned into a scrub cycle (i.e. Read Modify Write to correct the errors).

Each block of memory may be populated with different sized DRAM components, however, all banks

within a given block must be populated with the same size device. For simplicity, the Refresh Address Counter treats every block as if it were populated with DRAMS of maximum (16 Mbit) capacity.

5 When refreshing smaller memories, the same address location will be scrubbed multiple times before the counter advances to the next location. The scrub repetition count can be expressed as

$$R = 2^{(12-M)}$$

10 Where R is the repetition count in this expression and M is the log₂ of the square root of the smaller memory's size.

15 While the preferred embodiments of the present invention have been shown and described, it will be apparent to those skilled in the art that many more modifications are possible without departing from the spirit and scope of the invention. For example, the memory may be configured with different number of blocks. The memory system or

20 principles can also be used with system buses other than M-Bus. FEDC 30 can be constructed with a different number of channels and the channel data width may also vary depending on system requirements.

WHAT IS CLAIMED IS:

1. A memory system coupled to a system bus which is further coupled to a plurality of processors, each of said plurality of processors associated with at least one data cache, said memory system comprising:
- memory means for storing said data;
 - control means for receiving address and control signals from said system bus and for controlling transfer of said data to and from said memory means to and from said system bus, said control means including an address separating means for separating read address signals from write address signals, and a write control signal separating means for separating write control signals from read control signals; and
 - sending and receiving means coupled between said system bus and said memory means and under control of said control means, said sending and receiving means for sending and receiving said data to and from said system bus to and from said memory means, said sending and receiving means including at least one write first-in-and-first-out (FIFO) buffer means for temporarily storing data received from said system bus during a cache purge operation, and for allowing said data cache to obtain data from said memory means, at any time, without loss of said data previously stored in said write FIFO buffering means, so that efficiency of said data transfers between said processors and said memory means is enhanced.

2. The memory system of claim 1, wherein said address separating means further comprises a

first write address path for a first write transaction address signal, and a second write address path including a write address register means for holding a second write transaction address signal, and wherein said write control separating means further includes a first write control path for first write control signal, and a second write control path including a write control register means for holding a second write transaction control signal.

3. The memory system of claim 2 further comprising a first multiplexing means for selecting a write address signal from one of said two write address paths, and a second multiplexing means for selecting a write control signal from one of said two write control paths.

4. The memory system of claim 1, wherein said write FIFO buffer means is further used for buffering normal write data, including all M-Bus write transactions.

5. The memory system of claim 1, wherein said sending and receiving means further comprises at least one first-in-and-first-out (FIFO) means for capturing data on said system bus, said captured data being transferred from one of said data caches associated with one of said processors to another of said data caches associated with a data requesting processor, such that said captured data is simultaneously stored in said capturing FIFO means and in said data cache of said data requesting processor.

6. The memory system of claim 1 or 5,
wherein said control means further comprises
control register means for storing system
information including system bus size and memory
5 structure information.

7. The memory system of claim 5, wherein
said control means further comprises an address
comparator means for comparing said write address
and said read address to determine priority of
10 access to said memory means.

8. A memory system coupled to a system bus,
comprising:

memory means for storing data;
control means for receiving address and
15 control signals from said system bus, and said
control means for controlling transfer of said data
to and from said memory means, said control means
including an address path means for transferring
said address signals and a control path means for
20 transferring said control signals, said address
path means further including a read address path
and a write address path, said write address path
further including a first write address path and a
second write address path, and said control path
25 means further including a read control path and a
write control path, said write control path further
including a first write control path and a second
write control path; and

means for sending and receiving said data
30 to and from said system bus to and from said memory
means, said sending and receiving means including
at least one write first-in-and-first-out (FIFO)
means for temporarily storing said data received

from said system bus whose address is provided by one of said first or second write address paths.

9. The memory system of claim 8, wherein said address path means further comprises a write address register means located in said second write address path for holding a first write transaction address signal from said second address path, and said control path means further comprises a write control register means located on said second write control path for holding a second control signal from said second write control path.

10. The memory system of claim 8 further comprising an address comparator means for comparing a write address through said write address path and a read address through said read address path, to determine priority of access to said memory means.

11. A memory system coupled to a system bus which is further coupled to a plurality of processors, each of said plurality of processors associated with at least one data cache, said memory system comprising:

- memory means for storing said data;
- control means for receiving address and control signals from said system bus and for controlling transfer of said data to and from said memory means to and from said system bus; and
- sending and receiving means coupled between said system bus and said memory means and under control of said control means for sending and receiving said data to and from said system bus to and from said memory means, said sending and

receiving means including at least one reflective
read first-in-and-first-out (FIFO) buffer means for
capturing said data on said system bus, said
captured data being transferred from one of said
5 data caches associated with one of said plurality
of processors to another of said data caches
associated with a data requesting one of said
plurality of processors, such that said data is
simultaneously stored in said reflective-read FIFO
10 means and in said cache associated with said data
requesting processor.

12. A memory system coupled to a system bus
which is coupled to a plurality of processors, each
of said plurality of processors is associated with
15 at least one data cache, said plurality of
processors for processing data, said memory system
comprising:

memory means for storing said data;
sending and receiving means for sending
20 and receiving said data to and from said system bus
to and from said memory means, said sending and
receiving means including at least one data channel
means which has a write data path and a read data
path, said data channel means further including a
25 write first-in-and-first-out (FIFO) means located
on said write data path for buffering said data
among a normal write data and a cache purge write
data during a cache purge operation, and said data
channel means further including a reflective first-
30 in-and-first-out (FIFO) means located on said write
data path for capturing said data when said system
bus is executing a coherent-read operation, said
sending and receiving means further including an
error detection and correction (EDC) means located

on said read data path for detecting errors and
correcting detected errors during read operations;
and

control means for providing control
5 signals to said memory means and to said sending
and receiving means.

13. The memory system of claim 12, wherein
said EDC means is further used for detecting and
correcting read-out data errors during a write
10 which has a data length less than a word, said
corrected data being sent to said write data path
to be combined with said write data bytes.

14. The memory system of claim 12, wherein
said memory means is a dynamic random access memory
15 (DRAM).

15. A memory system coupled to a system bus,
comprising:

memory means for storing data, said
memory means including at least one block, and said
20 block including a plurality of banks, each of said
plurality of banks can be accessed simultaneously,
and each of which has the same predetermined
bandwidth;

sending and receiving means for sending
25 and receiving data to and from said system bus to
and from said memory means, said sending and
receiving means including a plurality of data
channel means for respectively providing a data
channel which can access at least one of said
30 plurality of banks in said at least one block of
said memory, each of said data channel means
further including a buffering means for buffering

said data to be stored in said memory means, and said data channel means further including a read means for correctly transferring read data to said system bus; and

5 control means for receiving address and control signals from said system bus means, said control means for controlling transfer of said data to and from said memory means to and from said system bus means, said control means including a
10 bus size programing means for programing bus size information, and said control means further including a means for selecting at least one of said data channel means during a memory operation depending on bus size of said system bus programmed
15 in said bus size programing means, and depending on data size to be transferred.

16. The memory system of claim 15, wherein said buffering means further comprises a write FIFO means for buffering write data among a normal write
20 data and a cache purge write data during a cache purge operation, and said buffering means further includes a reflective FIFO means for capturing data during a coherent-read operation.

17. The memory system of claim 15, wherein
25 said read means comprises an error detection and correction (EDC) means for detecting errors and correcting said detected errors during read operations.

18. The memory system of claim 17, wherein
30 said EDC means is also used for detecting and correcting read-out data errors during a write operation which have a data length less than a

word, said corrected data being sent to said write data path to be combined with the write bytes.

19. The memory system of claim 15, wherein each of said banks in said memory means has a 32-bit data width.

20. The memory system of claim 15, wherein each of said data channel means has a 32-bit data width, which can access one of said plurality of banks in said memory means.

21. The memory system of claim 15, wherein each of said data channel means has a 64 bit data width, which can access at least one of said plurality of banks in said memory means.

22. The memory system of claim 23, wherein two of said plurality of data channel means are combined into a single unit and made into a monolithic integrated circuit.

23. The memory system of claim 22, wherein said sending and receiving means further comprises at least two of said units depending on the maximum bus size of said system bus that said memory system is designed to support.

24. The memory system of claim 23, wherein said control means further comprises means for selecting one or more of said units in a memory operation depending on said bus size of said system bus and on data size to be transferred.

25. The memory system of claim 15, wherein
said control means further comprises a means for
programming a number of said blocks in said memory
means and selecting correct block in said memory
5 means.

26. The memory system of claim 15, wherein
said control means further comprises a means for
programming data width of said data channel means.

27. The memory system of claim 15, wherein
10 said control means further comprises frequency
multiplication means for providing a multiplied
memory clock frequency derived from a system bus
clock frequency, and for enhancing the timing
resolution of said memory system, and said control
15 means further comprises means for providing
frequency multiplication factors to said frequency
multiplication means depending on said system bus
clock frequency of said system bus.

28. The memory system of claim 15, wherein
20 said memory means is a dynamic random access memory
(DRAM).

29. The memory system of claim 15, wherein
said system bus is an M-Bus, said M-Bus can support
a plurality of processors, each of which is
25 associated with at least one data cache.

30. The memory system of claim 15, wherein
said memory means further comprises a plurality of
said blocks, each of said plurality of blocks are
configured with different DRAM types, said DRAM
30 types have different sizes, all of said plurality

of banks in one of said blocks being configured with an identical DRAM type.

31. The memory system of claim 19, wherein each of said plurality of banks in said memory means also comprises a plurality of parity check bits.

32. The memory system of claim 27, wherein said frequency multiplication means is a phase locked loop (PLL) multiplier.

33. The memory system of claim 15, wherein said system bus is one of 32-, 64- or 128-bit data wide system buses.

34. The memory system of claim 15, wherein said control means further comprises a program register means for storing timing control signals for said memory means under enhanced timing resolution.

35. The memory system of claim 16, wherein said write FIFO means and said reflective FIFO means are structured to accommodate 16 data words to support long burst data transfers.

36. A memory system coupled to a system bus, comprising:

memory means for storing data;
control means for controlling transfer of said data between said system bus and said memory means, said control means comprising:
program register means for storing information regarding bus clock frequency of said

system bus and frequency multiplication factor of said bus clock frequency; and

5 memory frequency multiplier means for providing a high memory clock frequency in response to said multiplication factor to support different bus speeds and to enhance timing resolution of said memory means.

10 37. The memory system of claim 36, wherein said control means further comprises a timing program means for programming timing control signals for said memory means.

38. A memory system coupled with a system bus, comprising:

15 memory means for storing data, said memory means including a plurality of blocks; control means for controlling access to said memory means, said control means comprising:

20 command program means for storing information with respect to the number of said plurality of blocks of said memory means;

location program means for programming locations of said blocks of said memory means in a overall memory map;

25 mask program means for programming mask bits to allow masking certain bits of said programmed locations in said location program means; and

30 comparator means for comparing an incoming address with said programmed locations of said memory means in said location program means to allow selection of one of said blocks of said memory means.

39. The memory system of claim 38, wherein each of said plurality of blocks comprises a plurality of banks formed by same type of memory devices, each of said plurality of banks have the same predetermined bandwidth, such that said memory means can support different bus sizes.

40. The memory system of claim 39, wherein said predetermined bandwidth of each of said plurality of banks further comprises a plurality of data bits and a plurality of parity check bits.

41. The memory system of claim 38, wherein said control means further comprises means for selecting proper banks depending on bus size of said system bus.

42. The memory system of claim 38, wherein said plurality of blocks of said memory means comprises different memory types which are further comprised of different memory sizes.

43. The memory system of claim 38, wherein said memory means is a dynamic random access memory (DRAM).

44. A memory system coupled to a system bus, comprising:

memory means for storing data, said memory means including at least one block, said at least one block further including a plurality of banks, each of said plurality of banks having the same predetermined bandwidth to support different bus sizes and different data transaction sizes; and control means for controlling data flows between said memory means and said system bus, said

control means including means for selecting proper one of said at least one block and means for programming bus size information, and means for selecting at least one of said plurality of banks depending on said bus size of said system bus and data size to be transferred.

45. The memory controller of claim 44 further comprising means for supporting different system bus speeds and means for enhancing timing resolution of said memory means.

46. The memory system of claim 45, wherein said supporting means further comprises a means for programming multiplication factors to a frequency multiplier based on incoming bus clock frequency.

47. The memory system of claim 44 further comprising a timing signal program means for programming timing of control signals of said memory means under enhanced timing resolution.

48. A memory system coupled to a system bus, comprising:

memory means for storing data, said memory means including at least one block which further includes a plurality of banks;

sending and receiving means for sending and receiving said data to and from said system bus to and from said memory means, said sending and receiving means including a plurality of data channel means for respectively providing a data channel, said data channel means for accessing at least one of said plurality of banks of said memory

means, and each of said data channel means further including a data buffer means for buffering said data to be stored in said memory means and a read means for transferring said data from said memory means to said system bus; and

5 control means for receiving address and control signals from said system bus and controlling transfer of said data to and from said memory means to and from said system bus, said
10 control means including means for selecting proper channels to support data transactions of different data lengths.

49. The memory system of claim 48, wherein said plurality of data channel means operate in an
15 alternating fashion during a long burst write to accumulate data in respective data buffer means to enhance data transfer efficiency.

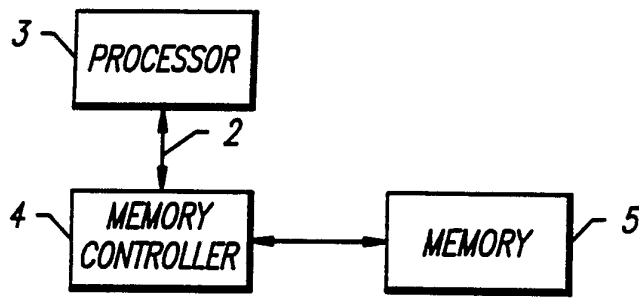

FIG. 1A

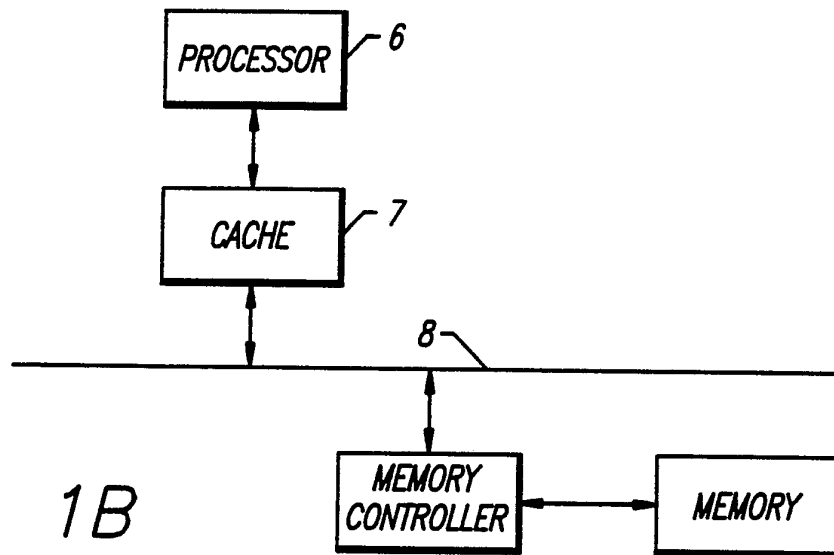

FIG. 1B

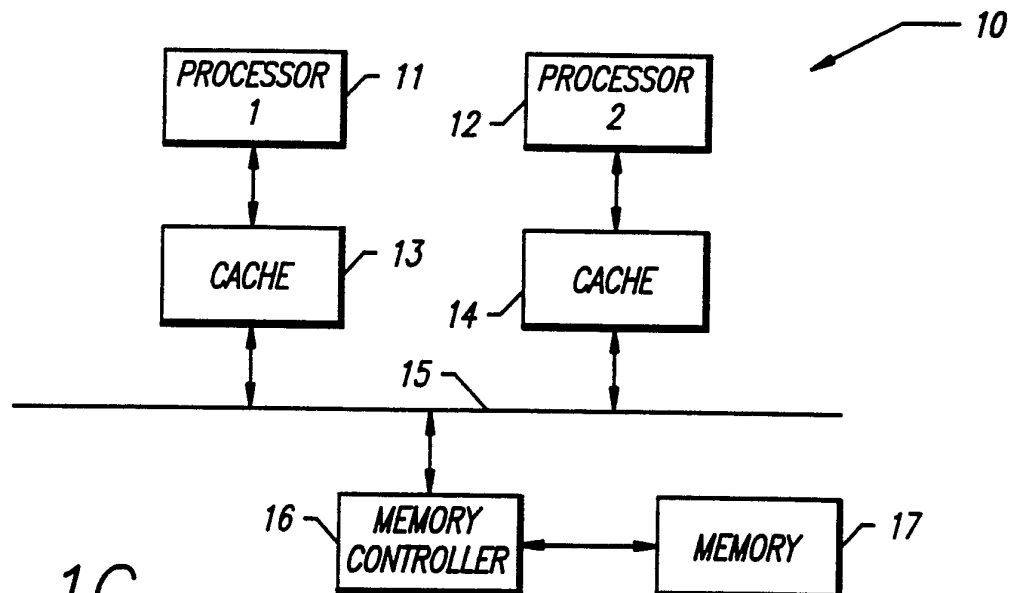

FIG. 1C

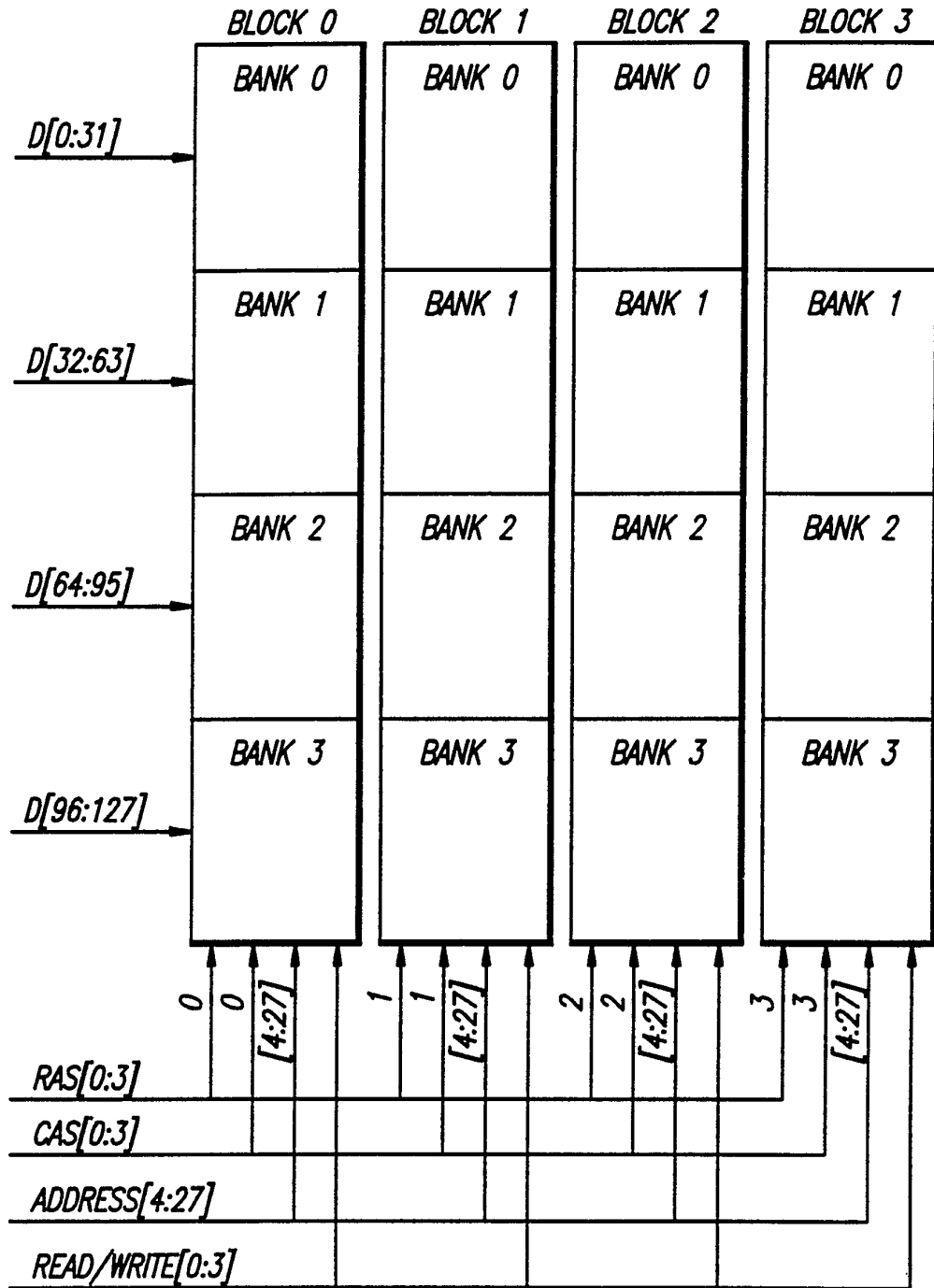

FIG. 2

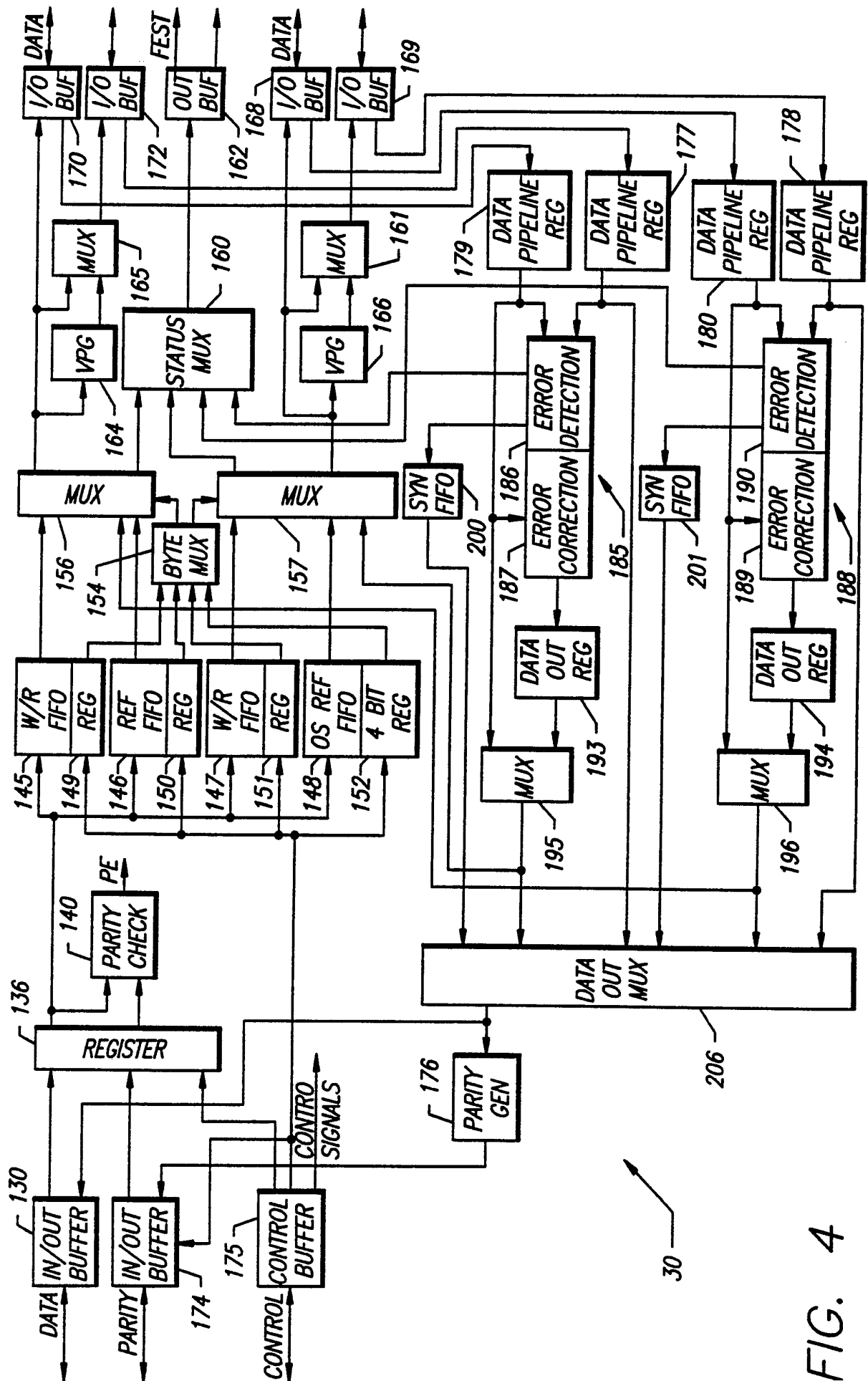

FIG. 4

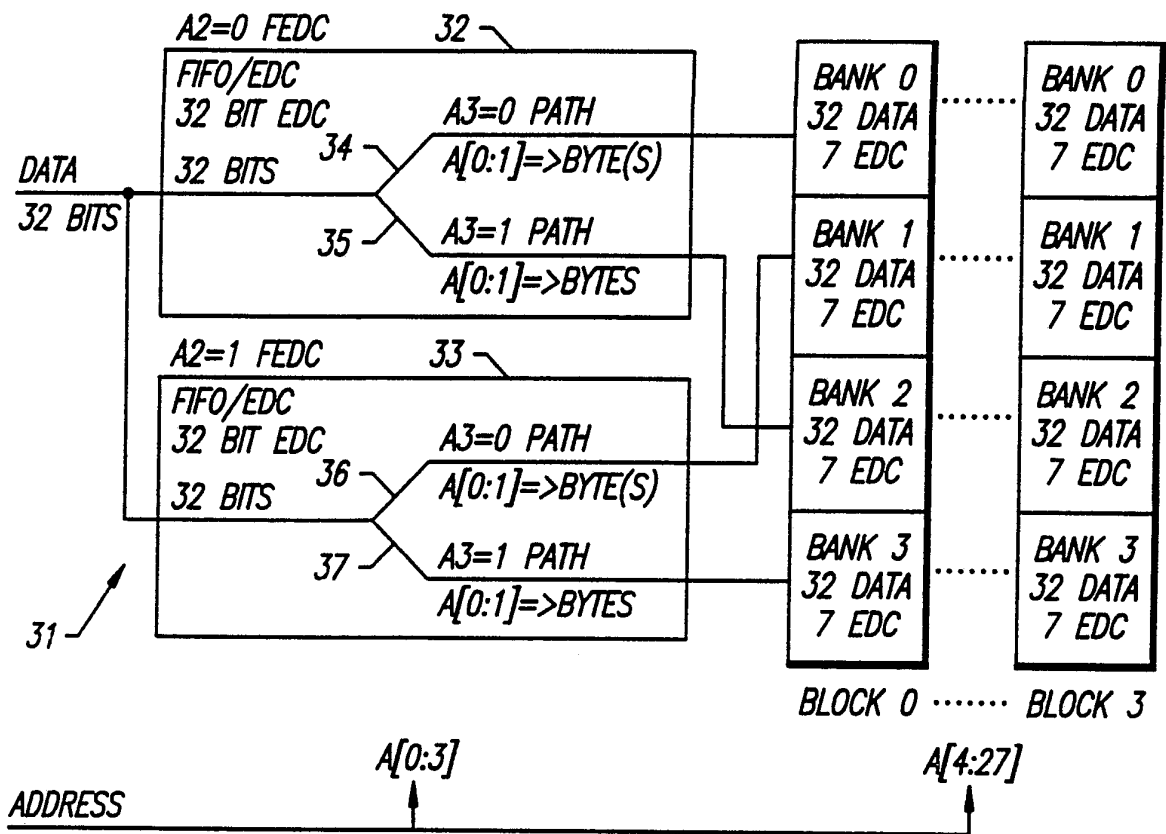

FIG. 6A

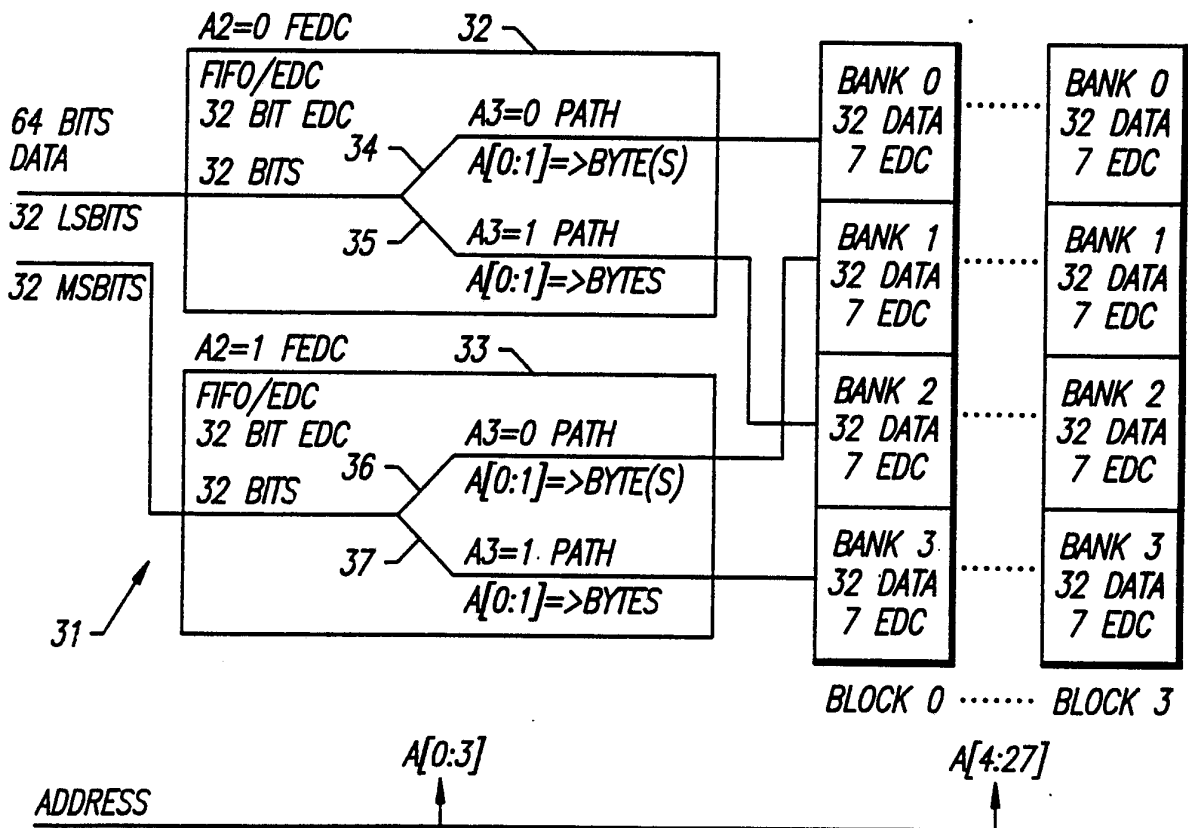

FIG. 6B

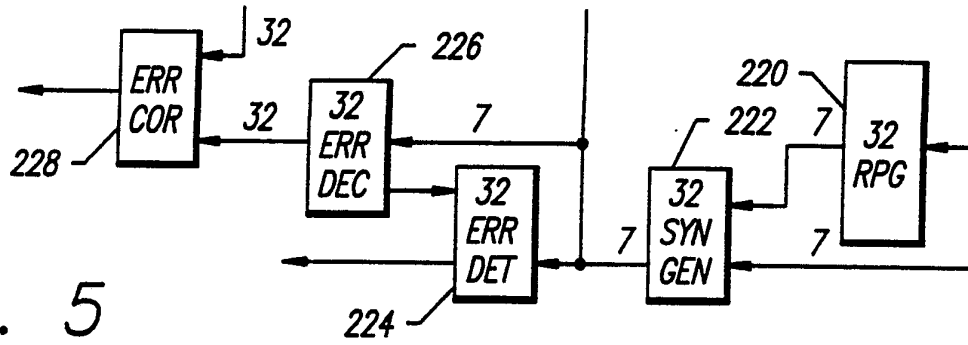

FIG. 5

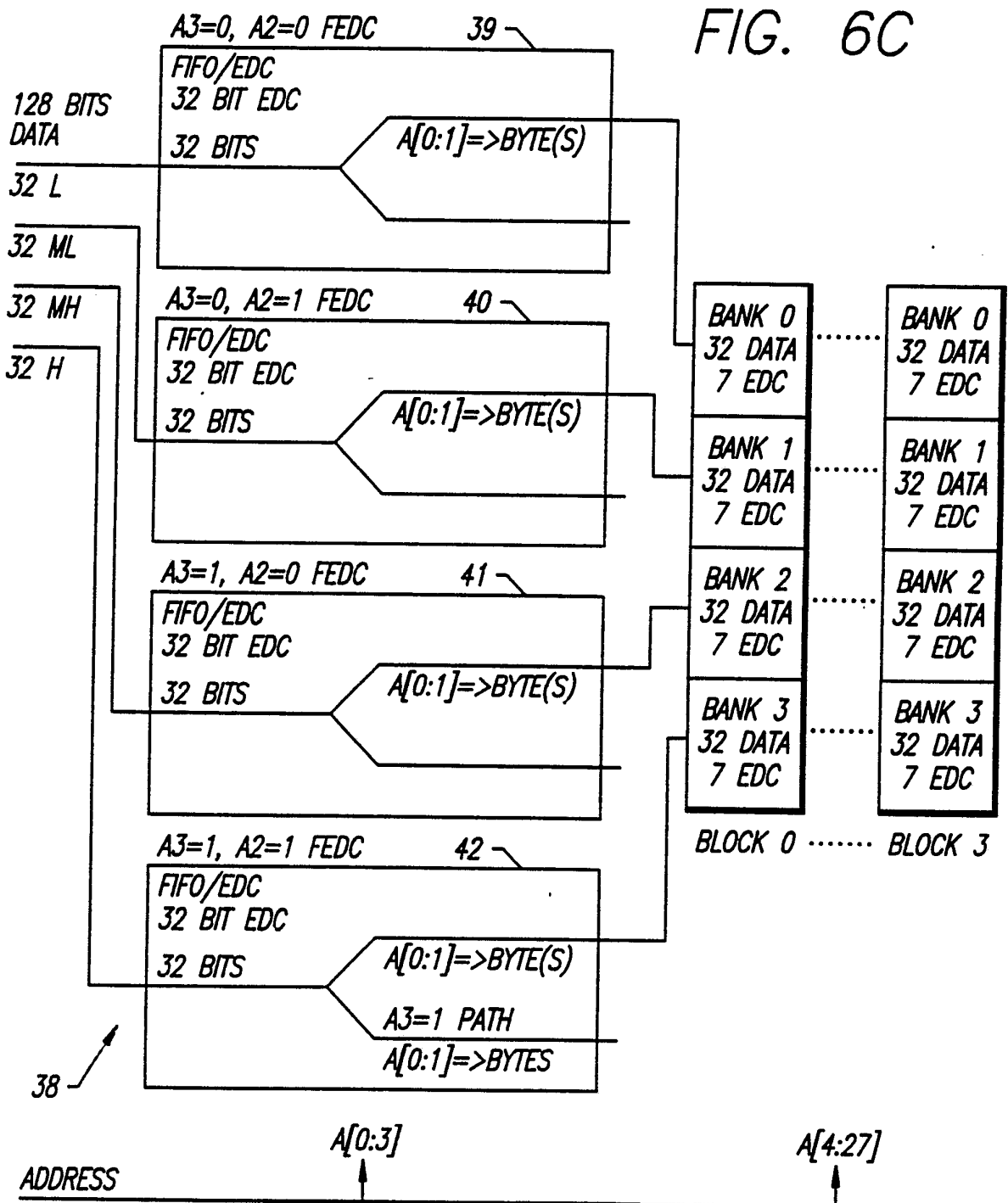

FIG. 6C

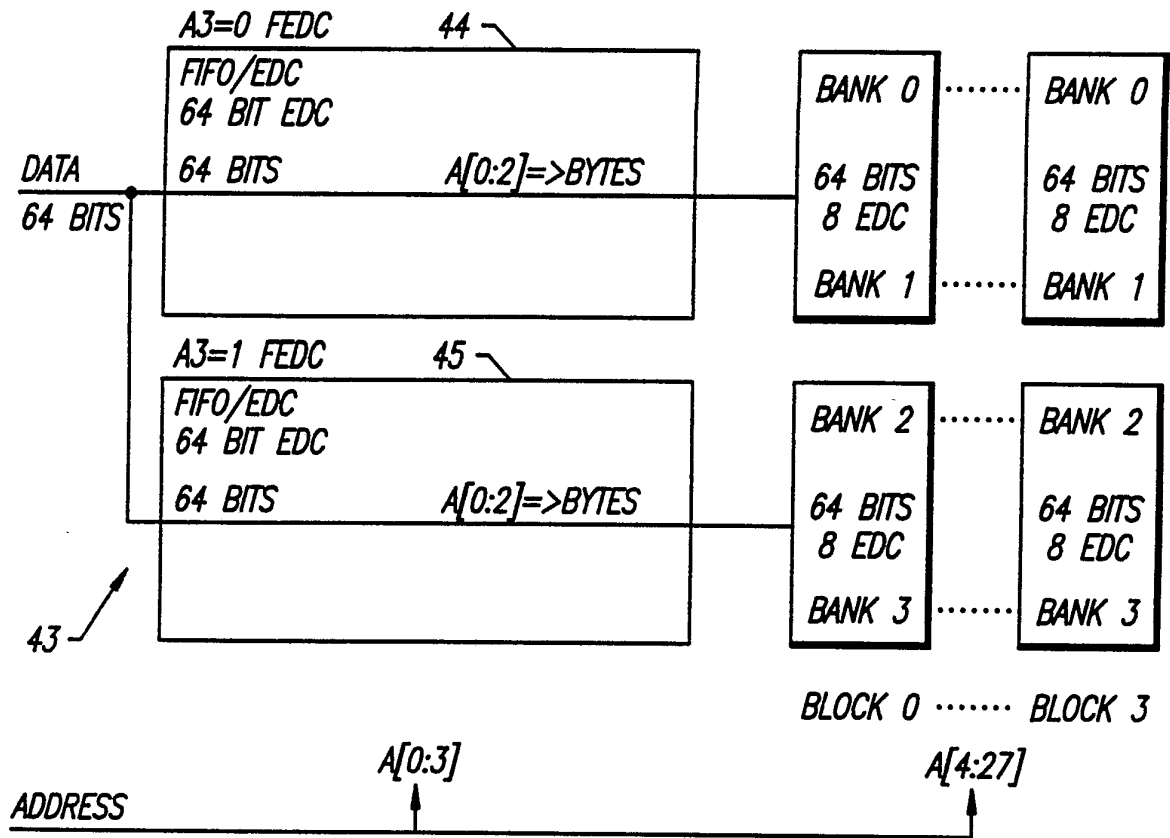

FIG. 6D

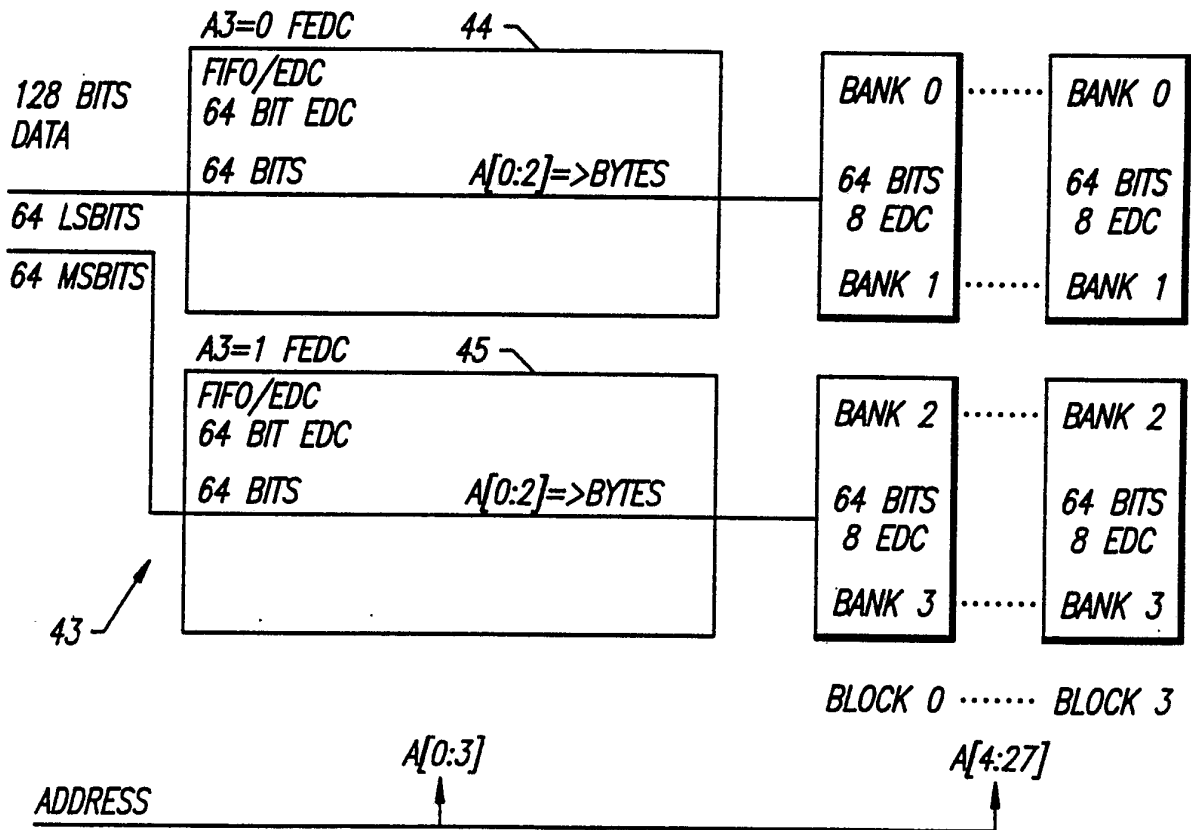

FIG. 6E