

Fig. 3

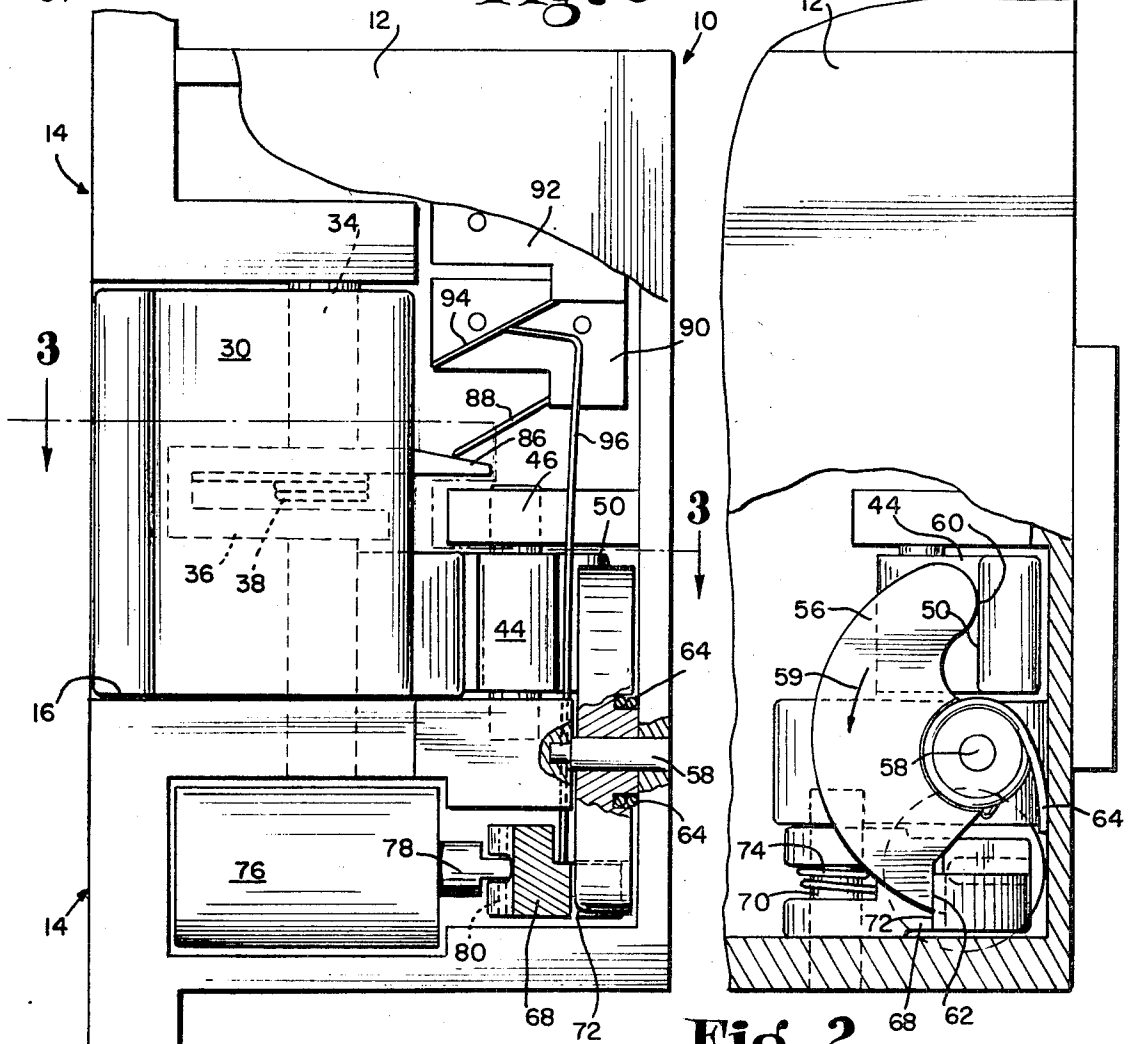

Fig. 2

Fig. 1

INVENTOR.

GEORGE Z. ZAWADZKI

BY MAKSIMILJAN GODEC

Hood, Gust, Irish Lundy & Coffey

ATTORNEYS

ELECTRIC LATCH STRIKE

It is an object of the present invention to provide, for use with a conventional latch bolt, an electrically operated strike assembly comprising a strike lip which is mounted for movement between its closed position effective to block the latch bolt and an open position which permits movement of the latch bolt and electrically operated locking means arranged selectively to permit movement of the lip from its closed position to its open position. Our strike assembly can be placed on a remote door frame and then operated from a centralized control panel to release the strike lip for movement by the latch bolt engaged therewith. It will be appreciated that our electrical strike assembly may be placed on each of several door frames located at remote points and then controlled from a central location.

It is an object of our present invention to provide a simple and inexpensive means for electrically releasing a strike lip, which means is extremely effective for the purpose intended. Our system is such that a locking member is moved electrically, i.e., by a solenoid, to permit the strike lip to be moved manually to its open position by the latch bolt which engages the strike lip. Our preferred strike lip is spring urged to its closed position. Thus, whenever the door is closed, the latch bolt must be retracted to pass the lip in its closed position. Conventionally, latch bolts are spring urged to their projected position so that they can be cammed inwardly to their retracted position to pass the strike lip.

Our preferred strike assembly includes switch means for indicating the position of the locking cam so that a person observing a control panel at a remote location will know whether or not entry can be made through the access opening on which the assembly is mounted. Another switch means is used to sense the presence of the latch bolt in its projected position relative to the strike assembly, this switch means being arranged to sound an alarm or otherwise to notify interested personnel when the latch bolt is moved.

Other objects and features of our present invention will become apparent as this description progresses.

To the accomplishment of the above and related objects, our invention may be embodied in the form illustrated in the accompanying drawings, attention being called to the fact, however, that the drawings are illustrative only, and that change may be made in the specific construction illustrated and described, so long as the scope of the appended claims is not violated.

In the drawings:

FIG. 1 is an elevational view, partially cut away, of the strike assembly showing the strike lip in its closed and locking position as it will appear from the outside of the door frame on which the assembly is mounted;

FIG. 2 is a fragmentary end view taken from the right-hand end of FIG. 1 and partially cut away and sectioned; and

FIG. 3 is a fragmentary sectional view taken from FIG. 1 generally along the line 3-3 and showing a conventional latch bolt engaged with the strike lip.

Referring now to the drawings, our preferred strike assembly, indicated generally at 10, will be discussed. The assembly 10 comprises a housing 12 which may be suitably conventionally formed by metal casting or other metal working processes, the housing providing an outer edge or surface 14 and several rigid bearing portions which will be mentioned hereinafter. The housing 12 is mounted in a door frame (not shown) so that the outer surface 14 is flush with the surface of the frame normally carrying the conventional strike plate and keeper. This surface 14 provides an access opening 16 into which the conventional latch bolt 18 (FIG. 3) extends.

In the illustrative embodiment of FIG. 3, the latch bolt 18 is shown mounted on a vertically extending pin 20 for pivotal movement with a conventional clevis 22, only a small portion of which is shown, pivotally connected to the latch bolt by means of a pin 24. Conventionally, the latch bolt 18 is pivotally movable about the pin 20 as indicated by the arrow 26 from its projected position illustrated in FIG. 3 to its retracted position (not shown) flush with the edge of the par-

tially illustrated door 28. Conventionally, the latch bolt 18 is yieldably biased by a spring (not shown) toward its projected position so that it can be cammed inwardly from its projected position to its retracted position. In FIG. 3, the latch bolt 18 is shown at the distal edge of the door 28 which, when opened, moves in the direction of the arrow 29.

Our strike assembly 10 includes a strike lip 30 which, when electrically released, is pivotally movable in the direction indicated by the arrow 32 in FIG. 3. In the illustrative embodiment, the strike lip 30, the lip portion of which engages and blocks the latch bolt 18, is mounted for pivotal movement by a vertically extending trunnion 34, the ends of which may be conventionally secured in rigid portions of the housing 12. Intermediate the ends of the trunnion 34 and in a suitable cavity formed in the lip 30, a trigger 36 is mounted to be pivotally movable about the trunnion 34. This trigger 36 serves a function which will be discussed hereinafter.

In FIGS. 1 and 3, we show spring means 38 to illustrate means for yieldably biasing the strike lip 30 to its closed position and the trigger 36 in a counterclockwise direction relative to the trunnion 34 as viewed in FIG. 3. It will be appreciated that one or more springs arranged in any conventional manner may be used to urge the lip 30 to its closed position and the trigger 36 in a counterclockwise direction.

The lip 30 provides a first abutment surface 42 extending outwardly relative to the axis of the trunnion 34, this abutment surface 42 being formed by a rigid portion of the lip as best seen in FIG. 3. We provide what we refer to as a load cam 44 which is mounted on a trunnion 46 extending generally parallel to the trunnion 34, the ends of this trunnion 46 also being conventionally secured in rigid portions of the housing 12. This load cam 44 provides a second abutment surface 48 and a third abutment surface 50, both of which extend outwardly relative to the axis of the trunnion 46. As clearly seen in FIG. 3, the abutment surface 42 and the abutment surface 48 are engaged so that pivotal movement of the lip 30 in the direction of the arrow 32 produces a pivotal movement of the cam 44 in the direction of the arrow 52.

Our assembly 10 also includes what we refer to as a connection cam 56 which is mounted on a trunnion 58 (FIGS. 1 and 2) for pivotal movement in the direction of the arrow 59 (FIG. 2) when the cam 44 moves in the direction of the arrow 52 (FIG. 3). This connection cam 56 provides a fourth abutment surface 60 which engages the third abutment surface 50 and another abutment surface 62. It will be appreciated that both abutment surfaces 60, 62 extend outwardly from or relative to the axis of the trunnion 58. In the illustrative embodiment, we provide a spring 64 which urges the connection cam 56 in a clockwise direction as viewed in FIG. 2, i.e., the abutment surface 60 against the abutment surface 50.

Referring to FIGS. 1 and 2, it will be seen that our assembly 10 includes what we refer to as a locking cam 68, but which may be considered as a blocking cam or simply as a locking member. This cam 68 is mounted for pivotal movement between a first position and a second position on a trunnion 70, the ends of which are also conventionally secured in rigid portions of the housing 12. Illustratively, we show a spring 74 conventionally arranged to urge the locking cam 68 to its first position. The cam 68 provides a sixth abutment surface 72 which extends outwardly relative to the axis of the trunnion 70 and which, when the cam 68 is in its first position, engages the fifth abutment surface 62 to prevent movement of the connection cam 56 in the direction of the arrow 59. In order selectively to move the locking cam 68 from its first position to its second position, we provide a solenoid 76, the armature 78 of which is pivotally connected as indicated at 80 to the cam 68. Thus, when the solenoid 76 is energized, the locking cam 68 is pulled in opposition to the spring 74 from its first position to its second position to permit the connection cam 56 to move in the direction of the arrow 59. When the solenoid is deenergized, the spring 74 will move the cam 68 to its first position and the armature 78 to its projected position.

With the above description in mind, it will be appreciated that the strike lip 30 is positively locked against movement in the direction of the arrow 32 by the engagement of the sixth abutment surface 72 with the fifth abutment surface 62. That is, unless and until the connection cam 56 can move in the direction of the arrow 59, the load cam 44 cannot move in the direction of the arrow 52 to permit movement of the strike lip in the direction of the arrow 32. As stated previously, the solenoid 76 can be operated from a remote control system to release the cams 56, and 44 for movement about their respective axes, thereby to permit movement of the strike lip 30. As soon as the door 28 is opened, the strike lip 30 will be moved to its closed position as illustrated in FIG. 3 by the spring means 38 discussed previously. Then, the spring 64 will be effective to return the cam 56 in the direction opposite to the arrow 59 to return the cam 44 in the direction opposite to the arrow 52 so that, when the solenoid 76 is deenergized, the locking cam 68 can be moved by its spring 74 to its first position. Thus, the first position of the locking cam 68 corresponds to the closed and locked condition of the lip 30 and the second position of the locking cam 68, i.e., the position to which it is moved by the solenoid 76, corresponds to the unlocked condition of the lip 30.

When the door 28 is moved to its closed position and the lip 30 is in its closed position, the latch bolt 18 will engage the strike and move to its retracted position against its own spring until the latch bolt is in its position illustrated in FIG. 3. Specifically, the latch bolt 18 is provided with a cam surface 82 which engages the outer rounded surface 84 of the lip 30 and the action of these two surfaces engaging causes the latch bolt to move to its retracted position.

It will be appreciated that the trigger 36 is engaged with the latch bolt 18 so that, if the latch bolt is moved, for any reason, the trigger 36 will be moved. A portion 86 (FIG. 1) of the trigger 36 engages an actuator arm 88 of a conventional microswitch 90 in such a manner that, when the trigger 36 is moved a predetermined amount about the trunnion 34, the switch 90 is operated to establish a predetermined circuit condition which is effective to sound an alarm or to turn on a signal light or the like. Thus, any efforts by an intruder to manipulate the latch bolt 18 can be detected. It will be appreciated that only a slight movement of the trigger 36 is necessary to operate the switch 90.

We propose to provide another switch 92, the actuator arm 94 of which is operatively connected by a linkage 96, for instance, to the cam 68 so that a predetermined electrical condition can be established when the cam 68 is in its second position, i.e., the position which will permit movement of the strike lip 30 to its open position. Thus, a proper control panel at a remote location can show the situation existing in the strike assembly 10.

Summarizing the above description, it will be appreciated that the assembly 10 comprises a strike lip 30, first means 34 mounting the lip for pivotal movement about a first axis between its closed position and its open position, the lip providing a first abutment surface 42 extending outwardly relative to this first axis. The assembly also includes a load cam 44, second means 46 mounting the load cam for pivotal movement about a second axis, this load cam providing second and third abutment surfaces extending outwardly relative to the second axis. The load cam drives a connection cam 56 and third means 58 is provided for mounting said connection cam for pivotal movement about the third axis. Finally, the assembly 10 includes a locking cam and fourth means 70 mounting the locking cam for pivotal movement about a fourth axis. It will be appreciated that the first, second and fourth axes are parallel and that the said third axis is perpendicular to the said first, second and fourth axes. In the illustrative embodiment, the first axis extends vertically, the second axis is parallel to the first axis, the third axis extends horizontally and perpendicular to the first and second axes, and the fourth axis extends vertically and parallel to the first and second axes.

Because of the use of cams 44 and 56 to change direction, we have provided an extremely compact strike assembly 10 which is extremely durable. The locking mechanism is designed to stand great forces against the lip 30, yet the solenoid 76 may be comparatively small and weak because its sole function is to move the locking cam 68 from its first position to its second position to release the mechanism.

It will be appreciated that the locking cam 68 acts as a hook in that, for the most part, forces directed against the abutment surface 72 by the connection cam 56 are applied through the center of the trunnion 70 and, therefore, do not tend to pivot the cam 68 about its axis.

Rigid stop means (not shown) is provided by the housing 12 to limit movement of the strike lip 30 clockwise as viewed in FIG. 3, such stop means establishing the closed position of the lip 30. The spring means 38 urges the lip 30 toward and against this stop means.

What is claimed is:

1. For use with a latch bolt, an electrically operated strike assembly comprising a strike lip, first means mounting said lip for movement between its closed position effective to block said latch bolt and an open position, solenoid means, a locking cam movable between a first position corresponding to the closed position of said lip and a second position, means providing an operative connection between said locking cam and said solenoid means to move said locking cam from its first position to its second position when said solenoid means is operated, and cam means drivingly associated with said lip to be moved thereby when said lip moves from its closed position to its open position, said locking cam being effective to prevent movement of said cam means by said lip when said locking cam is in its said first position.

2. The invention of claim 1 including switch means arranged to establish a predetermined circuit condition when said locking cam is moved from its first position to its second position.

3. For use with a latch bolt, an electrically operated strike assembly comprising a strike lip, first means mounting said lip for pivotal movement about a first axis between its closed position and its open position, said lip providing a first abutment surface extending outwardly relative to said first axis, a load cam, second means mounting said load cam for pivotal movement about a second axis, said load cam providing second and third abutment surfaces extending outwardly relative to said second axis, said first abutment surface engaging said second abutment surface so that pivotal movement of said lip toward its open position produces pivotal movement of said load cam, a connection cam, third means mounting said connection cam for pivotal movement about a third axis, said connection cam providing fourth and fifth abutment surfaces extending outwardly relative to said third axis, said fourth abutment surface engaging said third abutment surface so that pivotal movement of said load cam by said lip moving toward its open position produces pivotal movement of said connection cam, a locking cam, fourth means mounting said locking cam for pivotal movement about a fourth axis between a first position and a second position, said first position corresponding to the closed position of said lip and said second position corresponding to the open position of said lip, said locking cam providing a sixth abutment surface extending outwardly relative to said fourth axis, said fifth abutment surface engaging said sixth abutment surface when said locking cam is in its said first position, and solenoid means for selectively moving said locking cam from its first position to its second position to permit pivotal movement of said connection cam by said lip through said load cam.

4. The invention of claim 3 in which said first axis extends vertically, said second axis is parallel to said first axis, said third axis extends horizontally and perpendicular to said first and second axes, and said fourth axis extends vertically and parallel to said first and second axes.

5. The invention of claim 3 in which said first, second and fourth axes are parallel and said third axis is perpendicular to said first, second and fourth axes.

5

6

6. The invention of claim 5 including a first spring yieldably biasing said lip to its closed position, a second spring yieldably biasing said locking cam to its first position, and a third spring yieldably biasing said connection cam against said load cam.

7. The invention of claim 6 including a trigger mounted for pivotal movement about said first axis and positioned and arranged to engage the latch bolt cooperating with said strike assembly, and switch means operatively connected to said trigger and arranged to establish a predetermined circuit con-

dition when the latch bolt is moved relative to said trigger.

8. The invention of claim 7 including a spring yieldably urging said trigger against the latch bolt.

9. The invention of claim 3 including switch means having an actuator arranged to establish a predetermined circuit condition when said solenoid means is operated to permit movement of said strike lip to its open position.

* * * * *

10

15

20

25

30

35

40

45

50

55

60

65

70

75