



- (51) International Patent Classification:  
*H03L 7/06* (2006.01)    *H03L 7/07* (2006.01)
- (21) International Application Number:  
PCT/US2014/062057
- (22) International Filing Date:  
23 October 2014 (23.10.2014)
- (25) Filing Language: English
- (26) Publication Language: English
- (30) Priority Data:  
61/895,024    24 October 2013 (24.10.2013)    US
- (71) Applicant: **MARVELL WORLD TRADE LTD.**  
[BB/BB]; L'horizon, Gunsite Road, Brittons Hill,  
BB14027 St. Michael (BB).
- (72) Inventor: **WINOTO, Renaldi**; 8 Rainbow Circle, Dan-  
ville, California 94506 (US).
- (74) Agent: **CHO, Steve Y.**; 6100 219th Street SW, Suite 580,  
Mountlake Terrace, Washington 98043 (US).
- (81) Designated States (unless otherwise indicated, for every  
kind of national protection available): AE, AG, AL, AM,

AO, AT, AU, AZ, BA, BB, BG, BH, BN, BR, BW, BY, BZ, CA, CH, CL, CN, CO, CR, CU, CZ, DE, DK, DM, DO, DZ, EC, EE, EG, ES, FI, GB, GD, GE, GH, GM, GT, HN, HR, HU, ID, IL, IN, IR, IS, JP, KE, KG, KN, KP, KR, KZ, LA, LC, LK, LR, LS, LU, LY, MA, MD, ME, MG, MK, MN, MW, MX, MY, MZ, NA, NG, NI, NO, NZ, OM, PA, PE, PG, PH, PL, PT, QA, RO, RS, RU, RW, SA, SC, SD, SE, SG, SK, SL, SM, ST, SV, SY, TH, TJ, TM, TN, TR, TT, TZ, UA, UG, US, UZ, VC, VN, ZA, ZM, ZW.

- (84) Designated States (unless otherwise indicated, for every kind of regional protection available): ARIPO (BW, GH, GM, KE, LR, LS, MW, MZ, NA, RW, SD, SL, ST, SZ, TZ, UG, ZM, ZW), Eurasian (AM, AZ, BY, KG, KZ, RU, TJ, TM), European (AL, AT, BE, BG, CH, CY, CZ, DE, DK, EE, ES, FI, FR, GB, GR, HR, HU, IE, IS, IT, LT, LU, LV, MC, MK, MT, NL, NO, PL, PT, RO, RS, SE, SI, SK, SM, TR), OAPI (BF, BJ, CF, CG, CI, CM, GA, GN, GQ, GW, KM, ML, MR, NE, SN, TD, TG).

**Published:**  
— with international search report (Art. 21(3))

WO 2015/061622 A1

(54) Title: SAMPLE-RATE CONVERSION IN A MULTI-CLOCK SYSTEM SHARING A COMMON REFERENCE

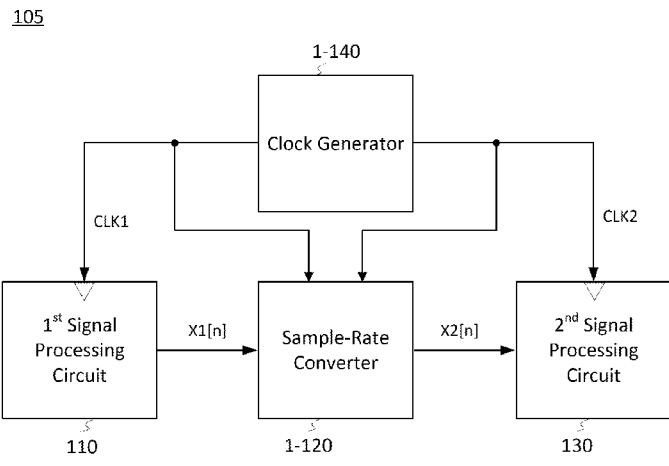

FIG. 1B

(57) **Abstract:** A method comprises determining a reference ratio based on a first division ratio of a first phase-locked loop (PLL) and a second division ratio of a second PLL, and converting a first discrete sequence to a second discrete sequence based on a sequence of multiples of the reference ratio. The first and second PLLs operate under a locked condition and share a common reference oscillator. An apparatus includes comprises a clock generator including first and second phase-locked loops (PLLs) and configured to generate first and second clock signals, respectively, and a sample-rate converter configured to convert a first discrete sequence to a second discrete sequence based on a sequence of multiples of a reference ratio. The reference ratio is determined based on a first division ratio of the first PPL and a second division ratio of the second PLL.

## SAMPLE-RATE CONVERSION IN A MULTI-CLOCK SYSTEM SHARING A COMMON REFERENCE

### CROSS REFERENCE TO RELATED APPLICATION

[0001] This present disclosure claims the benefit of U.S. Provisional Application No. 61/895,024, filed on October 24, 2013, which is incorporated by reference herein in its entirety.

### BACKGROUND

[0002] Electronic devices that transmit and receive different types of signals, such as telecommunication systems, may include a plurality of signal processing circuits. When one signal processing circuit using a first sampling frequency transmits a digital signal to the other signal processing circuit using a second sampling frequency, sample-rate conversion is desirable to change the sampling rate of the digital signal from the first sampling frequency to the second sampling frequency.

[0003] A conventional approach to sample rate conversion includes converting a digital signal to an analog signal, and then re-sampling the analog signal at a new sampling rate to obtain a new digital signal. However, this approach usually uses a digital-to-analog converter (DAC) and an analog-to-digital converter (ADC), and thus often results in undesirable signal distortion and expensive manufacturing cost.

[0004] Another conventional approach to sample rate conversion includes upsampling a digital signal sampled at a first sampling frequency to an intermediate conversion frequency that corresponds to a least common multiple of the first sampling frequency and a second sampling frequency, and then downsampling the upsampled digital signal to the second sampling frequency. However, when a ratio of the first and second sampling frequencies is not a whole number, the intermediate conversion frequency is high, and as a result the sample-rate conversion is computationally inefficient.

### SUMMARY

[0005] In an embodiment, a method comprises determining a reference ratio based on a first division ratio of a first phase-locked loop (PLL) and a second division ratio of a second PLL, and converting a first discrete sequence to a second discrete sequence based on a sequence of

multiples of the reference ratio. The first and second PLLs operate under a locked condition and share a common reference oscillator.

[0006] In an embodiment, the method further comprises writing the first discrete sequence in a storage device in response to a first clock signal and reading out the first discrete sequence from the storage device in response to a second clock signal.

[0007] In an embodiment, the storage device is a memory device and the memory device is an asynchronous first in first out (FIFO) buffer.

[0008] In an embodiment, the method further comprises accumulating the reference ratio to generate the sequence of multiples of the reference ratio.

[0009] In an embodiment, converting the first discrete sequence to the second discrete sequence includes converting the first discrete sequence to an upsampled discrete sequence. The upsampled discrete sequence has a sampling frequency higher than the first discrete sequence.

[0010] In an embodiment, the sampling frequency of the upsampled discrete sequence is a multiple of the sampling frequency of the first discrete sequence.

[0011] In an embodiment, the sampling frequency of the upsampled discrete sequence is no more than fifteen times of the sampling frequency of the first discrete sequence.

[0012] In an embodiment, converting the first discrete sequence to the second discrete sequence further includes selecting two consecutive values of the upsampled discrete sequence. A multiple of the reference ratio lies between sampling times of the consecutive values of the upsampled discrete sequence.

[0013] In an embodiment, converting the first discrete sequence to the second discrete sequence further includes interpolating the consecutive values of the upsampled discrete sequence to generate a value of the second discrete sequence.

[0014] In an embodiment, the consecutive values of the upsampled discrete sequence are linearly interpolated.

[0015] In an embodiment, the common reference oscillator includes a crystal oscillator.

[0016] In an embodiment, the reference ratio is an integer or a fixed precision fractional number.

[0017] In an embodiment, an apparatus comprises a clock generator including first and second phase-locked loops (PLLs) and configured to generate first and second clock signals, respectively, and a sample-rate converter configured to convert a first discrete sequence to a second discrete sequence based on a sequence of multiples of a reference ratio. The reference ratio is determined based on a first division ratio of the first PLL and a second division ratio of the second PLL. The first and second PLLs operate under a locked condition and share a common reference oscillator.

[0018] In an embodiment, the sample-rate converter includes an asynchronous first in first out (FIFO) buffer.

[0019] In an embodiment, the sample-rate converter includes an accumulator configured to accumulate the reference ratio to generate the sequence of multiples of the reference ratio.

[0020] In an embodiment, the sample-rate converter further includes first and second interpolators configured to generate two consecutive values of a upsampled discrete sequence, respectively. The upsampled discrete sequence has a sampling frequency higher than the first discrete sequence.

[0021] In an embodiment, the sample-rate converter further includes a third interpolator configured to interpolate the consecutive values of the upsampled discrete sequence to generate a value of the second discrete sequence. A multiple of the reference ratio lies between sampling times of the consecutive values of the upsampled discrete sequence.

[0022] In an embodiment, the third interpolator is a linear interpolator.

[0023] In an embodiment, the common reference oscillator includes a crystal oscillator.

[0024] In an embodiment, the first and second PLLs include an integer-N PLL or a fractional-N PLL.

### BRIEF DESCRIPTION OF THE DRAWINGS

[0025] FIG. 1A shows a block diagram of a communication device according to an embodiment. FIG. 1B is a block diagram of a portion of a digital subsystem shown in FIG. 1A according to an embodiment

[0026] FIG. 2 illustrates first and second discrete sequences corresponding to a continuous signal, according to an embodiment.

[0027] FIG. 3 is a block diagram of a clock generator shown in FIG. 1 according to an embodiment.

[0028] FIG. 4 is a block diagram of a sample-rate converter shown in FIG. 1 according to an embodiment.

[0029] FIGS. 5A and 5B illustrate upsampling and interpolation of a sample-rate converter shown in FIG. 1 according to an embodiment.

[0030] FIG. 6 is a flowchart of a process of sample-rate conversion according to an embodiment.

[0031] FIG. 7 illustrates a process of converting a first discrete sequence to a second discrete sequence according to an embodiment.

### DETAILED DESCRIPTION

[0032] FIG. 1A shows a communication device 100 according to an embodiment. The communication device 100 includes an antenna 101, a duplexer 102, a radio frequency-to-intermediate frequency (RF-to-IF) mixer 103, an analog-to-digital (A/D) converter 104, a digital subsystem 105, a transmitter circuit 106, and a digital-to-analog (D/A) converter 107.

[0033] Upon receiving an RF signal by the antenna 101, the duplexer 102 directs the received RF signal to the RF-to-IF mixer 103, which converts the RF signal into an IF signal. The A/D converter 104 converts the IF signal into a digital signal and outputs the digital signal to the digital subsystem 105 to process the digital signal. The digital subsystem 105 provides an output digital signal to the D/A converter 107 to convert the output signal into an analog signal. The transmitter circuit 106 processes the analog signal for radio transmission via the antenna 101 through the duplexer 102.

[0034] While FIG. 1A shows a wireless communication device 100 coupled to the antenna 101, embodiments are not limited thereto. The device 100 may be any type of a communication device including a digital signal processing system. In an embodiment, the communication device 100 is coupled to a coaxial cable, twisted pair, stripline, printed-circuit board trace, or other form of wired communication channel. In another embodiment, the communication device 100 is coupled to an optoelectronic device, such as a laser diode or optical modulator, which may be coupled to an optical communication channel.

[0035] FIG. 1B is a block diagram of a portion of the digital subsystem 105 shown in FIG. 1A according to an embodiment. The digital subsystem 105 includes a first signal processing circuit 110, a sample-rate converter 1-120, a second signal processing circuit 130, and a clock generator 1-140.

[0036] The first signal processing circuit 110 receives a first clock signal CLK1 and samples a continuous signal at a first sampling frequency of the first clock signal CLK1. The first signal processing circuit 110 transmits a first discrete sequence  $x1[n]$  to a sample-rate converter 1-120. In an embodiment, the first signal processing circuit 110 includes a baseband processor.

[0037] The sample-rate converter 1-120 receives the first discrete sequence  $x1[n]$  and changes the sampling rate from the first sampling frequency to a second sampling frequency of a second clock signal CLK2. As a result, the sample-rate converter 1-120 generates a second discrete sequence  $x2[n]$ , which is a new discrete representation of the continuous signal according to the second sampling frequency.

[0038] The second signal processing circuit 130 receives the second discrete sequence  $x2[n]$  to process the received sequence  $x2[n]$  using the second clock signal CLK2. In an embodiment, the second signal processing circuit 130 includes a circuit element in a radio-frequency (RF) section of a transceiver, which operates at a carrier frequency in a range of 2.4~2.5 GHz.

[0039] The clock generator 1-140 provides a plurality of clock signals including the first and second clock signals CLK1 and CLK2. In an embodiment, the clock generator 1-140 includes a plurality of phase-locked loops (PLLs) that share a common reference oscillator, as will be described in detail with reference to FIG. 3.

[0040] FIG. 2 illustrate first and second discrete sequences  $x1[n]$  and  $x2[n]$  corresponding to a continuous signal  $y(t)$ , according to an embodiment. In FIG. 2, the first sampling time  $t1[0]$  of the first discrete sequence  $x1[n]$  corresponds to the first sampling time  $t2[0]$  of the second discrete sequence  $x2[n]$  for illustrative convenience.

[0041] The first discrete sequence  $x1[n]$  is a sequence of quantized and sampled values of the continuous signal  $y(t)$  with a time spacing equal to a first sampling period  $T_{CLK1}$ , which is a reciprocal of a first sampling frequency  $f_{CLK1}$ . The second discrete sequence  $x2[n]$  is a sequence of quantized and sampled values of the continuous signal  $y(t)$  with a time spacing equal to a second sampling period  $T_{CLK2}$ , which is a reciprocal of a second sampling frequency  $f_{CLK2}$ . In an embodiment, the first sampling frequency  $f_{CLK1}$  is lower than the second sampling frequency  $f_{CLK2}$ , so that the first sampling period  $T_{CLK1}$  is longer than the second sampling period  $T_{CLK2}$  as illustrated in FIG. 2.

[0042] FIG. 3 is a block diagram of a clock generator suitable for use as the clock generator 1-140 of FIG. 1 according to an embodiment. In the embodiment shown in FIG. 3, first and second PLLs 320 and 330 share a common reference oscillator 310. In another embodiment, first and second delay locked loops (DLLs) are used instead of the first and second PLLs 320 and 330.

[0043] The common reference oscillator 310 generates a reference clock signal  $CLK_{ref}$  and transmits the reference clock signal  $CLK_{ref}$  to the first and second PLLs 320 and 330. The reference clock signal  $CLK_{ref}$  has a reference frequency  $f_{ref}$ . In an embodiment, the common reference oscillator 310 is a crystal oscillator.

[0044] The first PLL 320 receives the reference clock signal  $CLK_{ref}$  as an input signal and generates a first clock signal  $CLK1$  as an output signal. Under locked condition, the input signal  $CLK_{ref}$  and the output signal  $CLK1$  of the first PLL 320 bears an exact relationship with each other. As a result, where  $k_1$  denotes a first division ratio of the first PLL 320, the frequency  $f_{CLK1}$  of the first clock signal  $CLK1$  is related to the reference frequency  $f_{ref}$  of the reference clock signal  $CLK_{ref}$  as follows:

$$f_{CLK1} = f_{REF} * k_1 \quad \text{Equation 1.}$$

In an embodiment, the first PLL 320 is an integer-N PLL in which the first division ratio  $k_1$  has an integer value. In another embodiment, the first PLL 320 is a fractional-N PLL in which the first division ratio  $k_1$  is a fractional value  $d_1/n_1$ , where  $d_1$  and  $n_1$  are relatively prime integers.

**[0045]** The second PLL 330 receives the reference clock signal  $CLK_{ref}$  as an input signal and generates a second clock signal  $CLK2$  as an output signal. Under locked condition, the input signal  $CLK_{ref}$  and the output signal  $CLK2$  of the second PLL 330 bears an exact relationship with each other. As a result, where  $k_2$  denotes a second division ratio of the second PLL 330, the frequency  $f_{CLK2}$  of the second clock signal  $CLK2$  is related to the frequency  $f_{ref}$  of the reference clock signal  $CLK_{ref}$  as follows:

$$f_{CLK2} = f_{RE} * k_2 \quad \text{Equation 2.}$$

In an embodiment, the second PLL 330 is an integer-N PLL in which the second division ratio  $k_2$  has an integer value. In another embodiment, the second PLL 330 is a fractional-N PLL in which the second division ratio  $k_2$  is a fractional value  $d_2/n_2$ , where  $d_2$  and  $n_2$  are relatively prime integers.

**[0046]** A reference ratio  $k$  is determined based on the frequencies  $f_{CLK1}$  and  $f_{CLK2}$  of the first and second PLLs 320 and 330, respectively. In an embodiment, the reference ratio  $k$  is a ratio between the frequencies  $f_{CLK1}$  and  $f_{CLK2}$  of the first and second PLLs 320 and 330 and is represented as follows using Equations 1 and 2:

$$k = \frac{f_{CLK1}}{f_{CLK2}} = \frac{k_1}{k_2} \quad \text{Equation 3A.}$$

**[0047]** When the first and second division ratios  $k_1$  and  $k_2$  are the fractional values  $d_1/n_1$  and  $d_2/n_2$ , respectively, the reference ratio  $k$  between the frequencies  $f_{CLK1}$  and  $f_{CLK2}$  of the first and second PLLs 320 and 330 is represented as:

$$k = \frac{f_{CLK1}}{f_{CLK2}} = \frac{k_1}{k_2} = \frac{d_1 \cdot n_2}{d_2 \cdot n_1} \quad \text{Equation 3B.}$$

Thus, in an embodiment, the reference ratio  $k$  is either an integer or a fixed precision fractional number.

**[0048]** In an embodiment, at least one of the first and second frequencies  $f_{CLK1}$  and  $f_{CLK2}$  is generated using a frequency divider in addition to the first and second PLLs 320 and 330,



respectively. The frequency divider divides the frequency  $f_{\text{ref}}$  of the reference clock signal  $\text{CLK}_{\text{ref}}$  by an integer  $N$  to produce an offset frequency  $f_{\text{off}}$  equal to  $f_{\text{ref}}/N$ . The offset frequency  $f_{\text{off}}$  is combined with a multiple  $M$  of the reference clock signal  $\text{CLK}_{\text{ref}}$  to produce a clock frequency equal to  $f_{\text{ref}} * M + f_{\text{ref}}/N$ , a clock frequency equal to  $f_{\text{ref}} * M - f_{\text{ref}}/N$ , or both. A person of skill in the art in light of the teachings and disclosures herein would understand how to calculate a reference ratio  $k$  between the frequencies  $f_{\text{CLK1}}$  and  $f_{\text{CLK2}}$  in such an embodiment.

**[0049]** When either of the first and second PLLs 320 and 330 is susceptible to phase noise or jitter, which may result from PLL components including one or more of a phase detector, a low-pass filter, a voltage controlled oscillator, and a frequency divider, the respective frequencies  $f_{\text{CLK1}}$  and  $f_{\text{CLK2}}$  may vary. On the other hand, when the first and second PLLs 320 and 330 share the common reference oscillator 310 and operate under the locked condition, since the first and second division ratios  $k_1$  and  $k_2$  have fixed values, the reference ratio  $k$  between the division ratios  $k_1$  and  $k_2$  also has a fixed value. The value of the reference ratio  $k$  is used to determine sampling times of an output discrete sequence  $x_2[n]$  of the sample-rate converter 1-120 of FIG. 1, as will be described below in detail.

**[0050]** In an embodiment, one or both of the frequencies  $f_{\text{CLK1}}$  and  $f_{\text{CLK2}}$  of the first and second PLLs 320 and 330, and accordingly the first and second division ratios  $k_1$  and  $k_2$ , may vary. For example, in an embodiment, the first PLL 320 generates a clock for a baseband circuit that has a substantially fixed nominal frequency of 300 MHz, and the second PLL 330 generates a clock for a radio frequency (RF) circuit that has a frequency that varies between 2.412 and 2.482 GHz according to a selection of a channel. As a result, the reference ratio  $k$  may be recomputed when one or more of the first and second division ratios  $k_1$  and  $k_2$  change.

**[0051]** FIG. 4 is a block diagram of a sample-rate converter 4-120 suitable for the sample-rate converter 1-120 shown in FIG. 1 according to an embodiment. The sample-rate converter 4-120 includes an accumulator 440, a two-step interpolator 450, and a first in first out (FIFO) buffer 410.

**[0052]** The accumulator 440 receives a second clock signal  $\text{CLK2}$  and a value of a reference ratio  $k$  between first and second division ratios  $k_1$  and  $k_2$  of first and second PLLs. In response to the second clock signal  $\text{CLK2}$ , the accumulator 440 adds the received value of the reference ratio

$k$  to a value that has been previously stored in the accumulator 440, stores the added value in the accumulator 440, and outputs the added value to the two-step interpolator 450. In an embodiment, the accumulator 440 outputs a sequence  $k[i]$  of multiples of the ratio  $k$ , for example,  $0, k, 2k, 3k$ , and the like.

**[0053]** FIG. 5A illustrates a portion of the first and second discrete sequence  $x1[n]$  and  $x2[n]$  of FIG. 2 as a function of sampling times, which are normalized by the first sampling period  $T_{CLK1}$  of the first discrete sequence  $x1[n]$ . Assuming the first sampling time  $t1[0]$  of the first discrete sequence  $x1[n]$  corresponds to the first sampling time  $t2[0]$  of the second discrete sequence  $x2[i]$ , values of the sequence  $k[i]$  of multiples of  $k$  correspond to the consecutive sampling positions of the second discrete sequence  $x2[i]$  relative to the samples in the first discrete sequence  $x1[n]$ , as illustrated in FIG. 5A.

**[0054]** Referring back to FIG. 4, the two-step interpolator 450 receives the first discrete signal  $x1[n]$  to generate the second discrete signal  $x2[i]$  based on the sequence  $k[i]$  of the accumulator 440. The two-step interpolator 450 includes first and second interpolators 420A and 420B and a linear interpolator 430 (or a third interpolator 430).

**[0055]** The first and second interpolators 420A and 420B receive a plurality of members of the first discrete sequence  $x1[n]$ , a predetermined number  $N$ , and the sequence  $k[n]$  to respectively output first and second selected values  $u1[p]$  and  $u1[p+1]$  of an upsampled discrete sequence  $u1[j]$ , which has a sampling frequency equal to the sampling frequency  $f_{clk1}$  of the first discrete sequence  $x1[n]$  multiplied by a positive integer number  $N$ . The first and second selected values  $u1[p]$  and  $u1[p+1]$  are consecutive values of the upsampled discrete sequence  $u1[j]$ . The received value of the sequence  $k[i]$  indicates a time between the sampling times corresponding to these consecutive values  $u1[p]$  and  $u1[p+1]$  of the upsampled discrete sequence  $u1[j]$ . In an embodiment, the predetermined number  $N$  is a positive integer that is equal to or less than 15. For example, FIG. 5B shows the upsampled discrete sequence  $u1[j]$ , which has the sampling frequency four times (i.e.,  $N=4$ ) higher than the frequency  $f_{clk1}$  of the first discrete sequence  $x1[n]$ .

**[0056]** In an embodiment, the index  $p$  of the first selected value  $u1[p]$  is determined according to the following equation:

$$p = \lfloor N * k[i] \rfloor \quad \text{Equation 4,}$$

where  $\lfloor \cdot \rfloor$  is a floor function, and  $N$  is an upsampling ratio. For example, when the received value of the sequence  $k[i]=0.9$  and the upsampling ratio  $N$  is 4, the index  $p$  of the first selected value  $u1[p]$  is equal to 3 ( $=\lfloor 4 * 0.9 \rfloor$ ). Thus, the first selected value  $u1[p]$  corresponds to the fourth member  $u1[3]$  of the upsampled discrete sequence  $u1[j]$ . As a result, the second selected value  $u1[p+1]$  corresponds to the fifth member  $u1[4]$  of the upsampled discrete sequence  $u1[j]$ .

**[0057]** The first interpolator 420A interpolates the first discrete sequence  $x1[n]$  to generate the first selected value  $u1[p]$ . The second interpolator 420B interpolates the first discrete sequence  $x1[n]$  to generate the second selected value  $u1[p+1]$ . In an embodiment, the first interpolator 420A and the second interpolator 420B have substantially the same configuration. In an embodiment, interpolation is performed using zero-padding and low pass filtering.

**[0058]** The linear interpolator 430 receives the consecutive values  $u1[p]$  and  $u1[p+1]$  of the upsampled discrete sequence and a value of the sequence  $k[n]$  and linearly interpolates the consecutive values  $u1[p]$  and  $u1[p+1]$  to generate the second discrete sequence  $x2[i]$ . In an embodiment illustrated in FIG. 5B, a value of the second member  $x2[1]$  of the second discrete sequence  $x2[i]$  between two consecutive values  $u1[3]$  and  $u1[4]$  of the upsampled discrete sequence is calculated as follows:

$$x2[1] = (1 - \alpha) * u1[3] + \alpha * u1[4] \quad \text{Equation 5,}$$

where  $\alpha$  is a weighting factor for linear interpolation. In this embodiment, the weighting factor  $\alpha$  is calculated according to the following equation:

$$\alpha = N * k[i] - p \quad \text{Equation 6,}$$

where  $N$  is an upsampling ratio and  $p$  is the index of the first selected value  $u1[p]$ . For example, when the received value of the sequence  $k[i]$  is 0.9, the upsampling ratio  $N$  is 4, and the index  $p$  of the first selected value  $u1[p]$  is equal to 3 as illustrated in FIG. 5A, the weighting factor  $\alpha$  is equal to 0.6 ( $=4*0.9-3$ ). As a result, the value of the second member  $x2[1]$  the second discrete sequence  $x2[i]$  is  $0.4*u1[3]+0.6*u1[4]$ . When the received value of the sequence  $k[i]$  is 1.8, the upsampling ratio  $N$  is 4, and the index  $p$  of the first selected value  $u1[p]$  is equal to 7 as

illustrated in FIG. 5A, the weighting factor  $\alpha$  is equal to 0.2 ( $=4*1.8^{-7}$ ). As a result, the value of the third member  $x2[2]$  of the second discrete sequence  $x2[i]$  is  $0.8*u1[7]+0.2*u1[8]$ .

[0059] Referring back to FIG. 4, the FIFO buffer 410 receives the first and second clock signals CLK1 and CLK2 and the first discrete sequence  $x1[n]$  to manage data flow into the two-step interpolator 450. In an embodiment, the FIFO buffer 410 writes the first discrete sequence  $x1[n]$  into the FIFO buffer 410 and reads the same sequence  $x1[n]$  out based on the first and second clock signals CLK1 and CLK2 to prevent data overflow or underflow. A person of skill in the art in light of the teachings and disclosures herein would understand how to implement the FIFO buffer 410.

[0060] FIG. 6 is a flowchart of a process of sample-rate converting according to an embodiment.

[0061] At S610, a reference ratio is determined based on two division ratios of first and second PLLs, which shares a common reference oscillator to respectively generate first and second clock signals under locked condition. Under the locked condition, the reference ratio between the division ratios is maintained substantially constant. In an embodiment, the reference ratio is a ratio between the division ratios.

[0062] At S6-650, a first discrete sequence obtained by sampling a continuous signal at a first frequency of the first clock signal is converted to a second discrete sequence based on a sequence of multiples of the reference ratio between the division ratios of the PLLs. The second discrete sequence is equivalent to a signal obtained by sampling the continuous signal at a second frequency of the second clock signal.

[0063] FIG. 7 illustrates a process 7-650 of converting a first discrete sequence to a second discrete sequence according to an embodiment.

[0064] At S710, writing the first discrete sequence in a storage device (e.g., a memory device) and reading out the same sequence out from the storage device based on first and second clock signals are performed to prevent data overflow and/or underflow. In an embodiment, the storage device a memory device in a form of an asynchronous FIFO buffer.

[0065] At S730, the first discrete sequence is converted to an upsampled discrete sequence, which has a sampling frequency equal to the sampling frequency of the first discrete sequence multiplied by a positive integer number. In an embodiment, the positive integer number is equal to or less than 15.

[0066] At S750, two consecutive values (or first and second selected values) of the upsampled discrete sequence are selected such that the consecutive values correspond to consecutive sampling times of the upsampled discrete sequence between which a multiple of the reference ratio lies.

[0067] At S770, the selected consecutive values of the upsampled discrete sequence are interpolated to obtain a corresponding value of the second discrete sequence. In an embodiment, the selected consecutive values are linearly interpolated.

[0068] Aspects of the present disclosure have been described in conjunction with the specific embodiments thereof that are proposed as examples. Numerous alternatives, modifications, and variations to the embodiments as set forth herein may be made without departing from the scope of the claims set forth below. Accordingly, embodiments as set forth herein are intended to be illustrative and not limiting.

WHAT IS CLAIMED IS:

1. A method comprising:  
determining a reference ratio based on a first division ratio of a first phase-locked loop (PLL) and a second division ratio of a second PLL; and  
converting a first discrete sequence to a second discrete sequence based on a sequence of multiples of the reference ratio,  
wherein the first and second PLLs operate under a locked condition and share a common reference oscillator.
2. The method of claim 1, further comprising:  
writing the first discrete sequence in a storage device in response to a first clock signal; and  
reading out the first discrete sequence from the storage device in response to a second clock signal.
3. The method of claim 2, wherein the storage device is a memory device, the memory device being an asynchronous first in first out (FIFO) buffer.
4. The method of claim 1, further comprising:  
accumulating the reference ratio to generate the sequence of multiples of the reference ratio.
5. The method of claim 1, wherein converting the first discrete sequence to the second discrete sequence includes:  
converting the first discrete sequence to an upsampled discrete sequence, the upsampled discrete sequence having a sampling frequency higher than the first discrete sequence.
6. The method of claim 5, wherein the sampling frequency of the upsampled discrete sequence is a multiple of the sampling frequency of the first discrete sequence.

7. The method of claim 6, wherein the sampling frequency of the upsampled discrete sequence is no more than fifteen times of the sampling frequency of the first discrete sequence.

8. The method of claim 5, wherein converting the first discrete sequence to the second discrete sequence further includes selecting two consecutive values of the upsampled discrete sequence, and

wherein a multiple of the reference ratio lies between sampling times of the consecutive values of the upsampled discrete sequence.

9. The method of claim 8, wherein converting the first discrete sequence to the second discrete sequence further includes:

interpolating the consecutive values of the upsampled discrete sequence to generate a value of the second discrete sequence.

10. The method of claim 9, wherein the consecutive values of the upsampled discrete sequence are linearly interpolated.

11. The method of claim 1, wherein the common reference oscillator includes a crystal oscillator.

12. The method of claim 1, wherein the reference ratio is an integer or a fixed precision fractional number.

13. An apparatus comprising:  
a clock generator including first and second phase-locked loops (PLLs) and configured to generate first and second clock signals, respectively; and  
a sample-rate converter configured to convert a first discrete sequence to a second discrete sequence based on a sequence of multiples of a reference ratio, the reference ratio being determined based on a first division ratio of the first PLL and a second division ratio of the second PLL,

wherein the first and second PLLs operate under a locked condition and share a common reference oscillator.

14. The apparatus of claim 13, wherein the sample-rate converter includes an asynchronous first in first out (FIFO) buffer.

15. The apparatus of claim 13, wherein the sample-rate converter includes an accumulator configured to accumulate the reference ratio to generate the sequence of multiples of the reference ratio.

16. The apparatus of claim 15, wherein the sample-rate converter further includes first and second interpolators configured to generate two consecutive values of a upsampled discrete sequence, respectively, the upsampled discrete sequence having a sampling frequency higher than the first discrete sequence.

17. The apparatus of claim 16, wherein the sample-rate converter further includes a third interpolator configured to interpolate the consecutive values of the upsampled discrete sequence to generate a value of the second discrete sequence, and  
wherein a multiple of the reference ratio lies between sampling times of the consecutive values of the upsampled discrete sequence.

18. The apparatus of claim 17, wherein the third interpolator is a linear interpolator.

19. The apparatus of claim 13, wherein the common reference oscillator includes a crystal oscillator.

20. The apparatus of claim 13, wherein the first and second PLLs include an integer-N PLL or a fractional-N PLL.



100

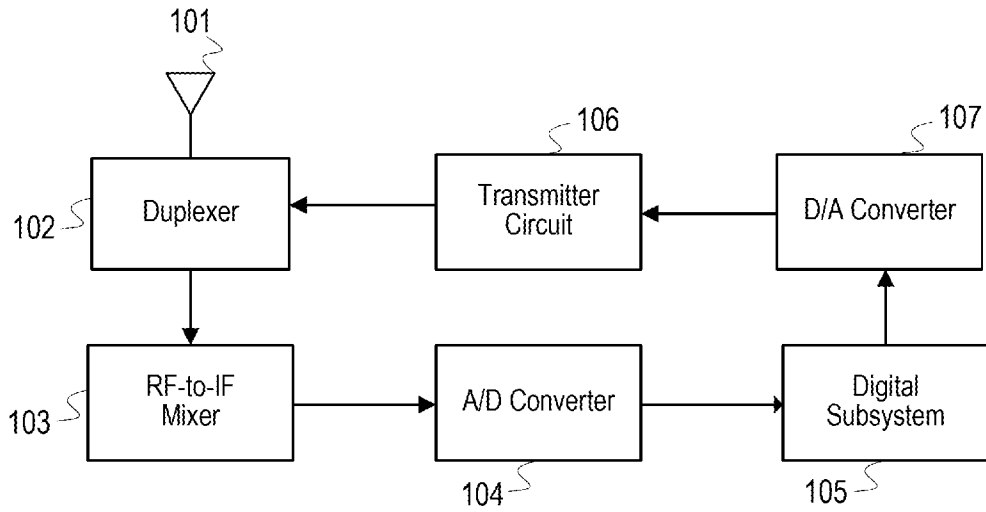

FIG. 1A

105

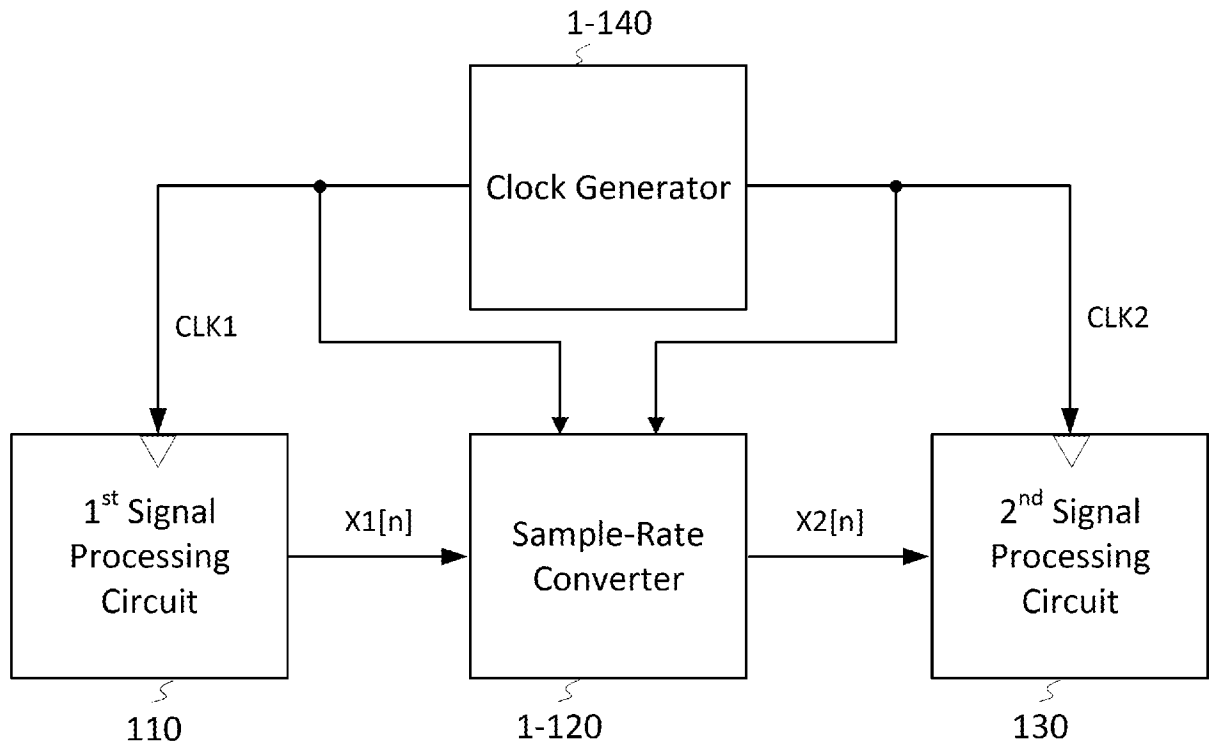

FIG. 1B

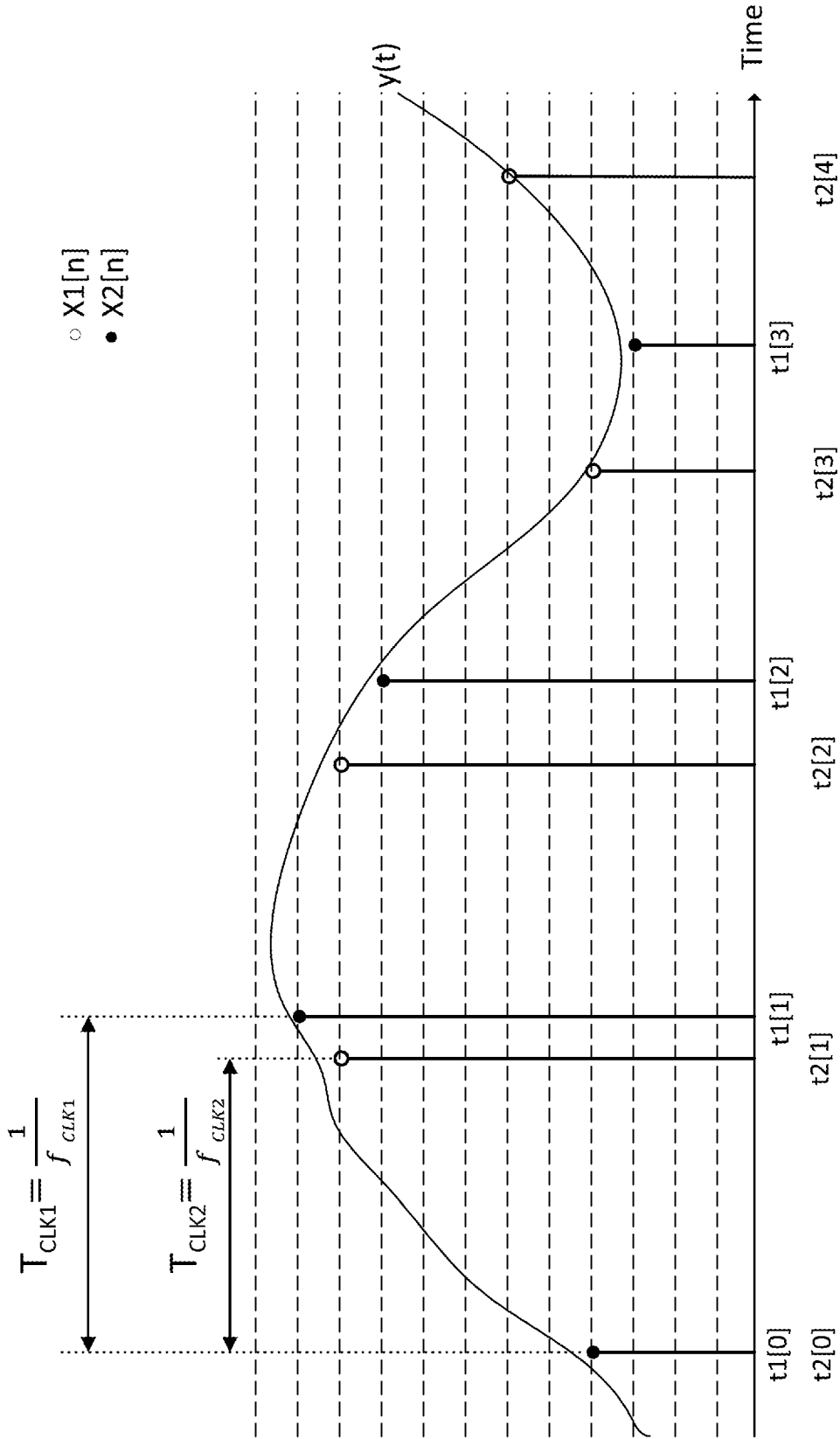

FIG. 2

3-140

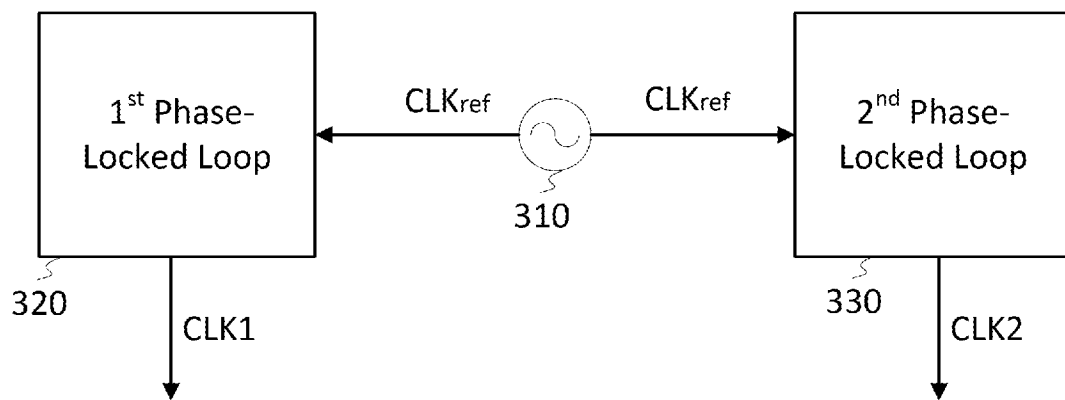
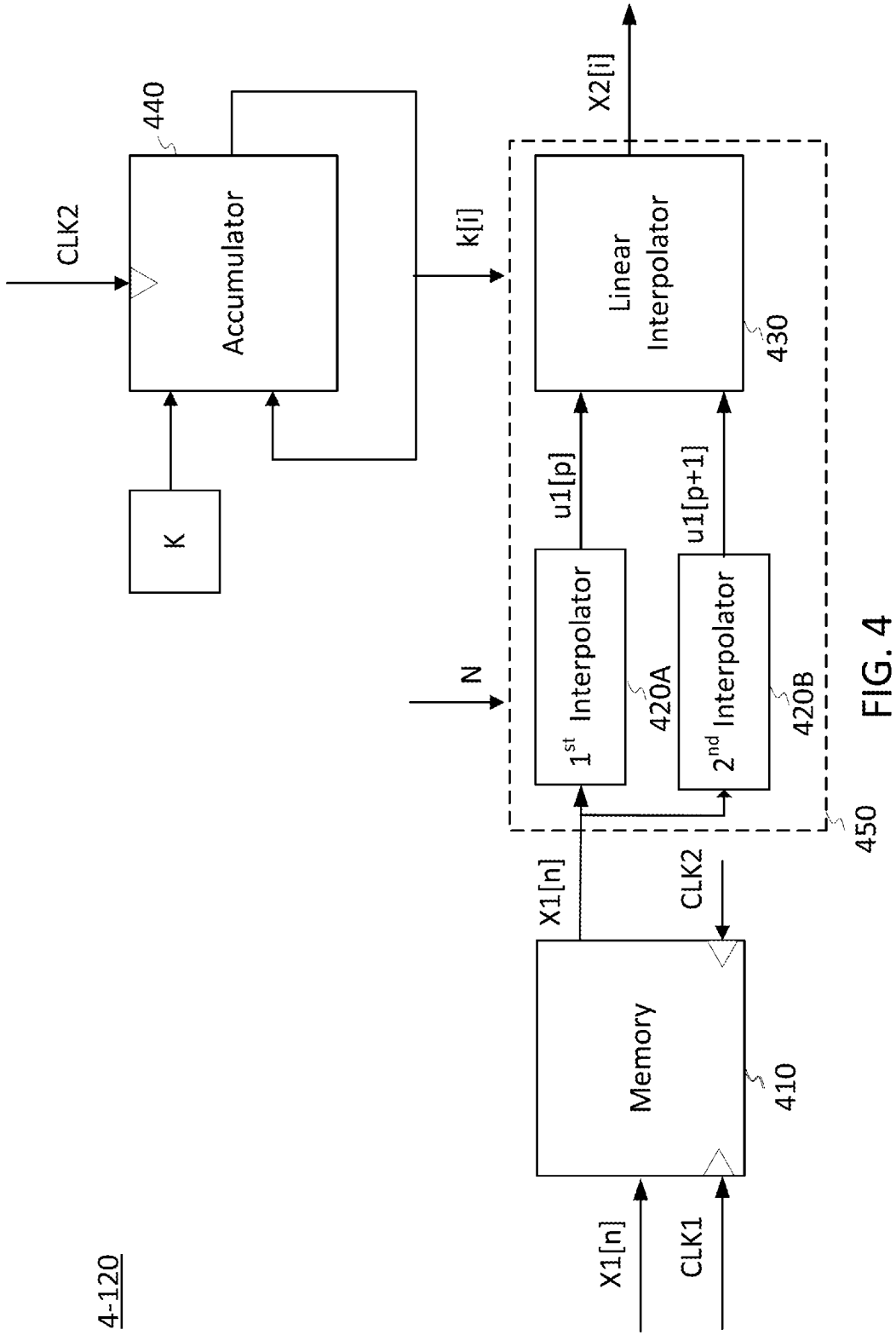

FIG. 3



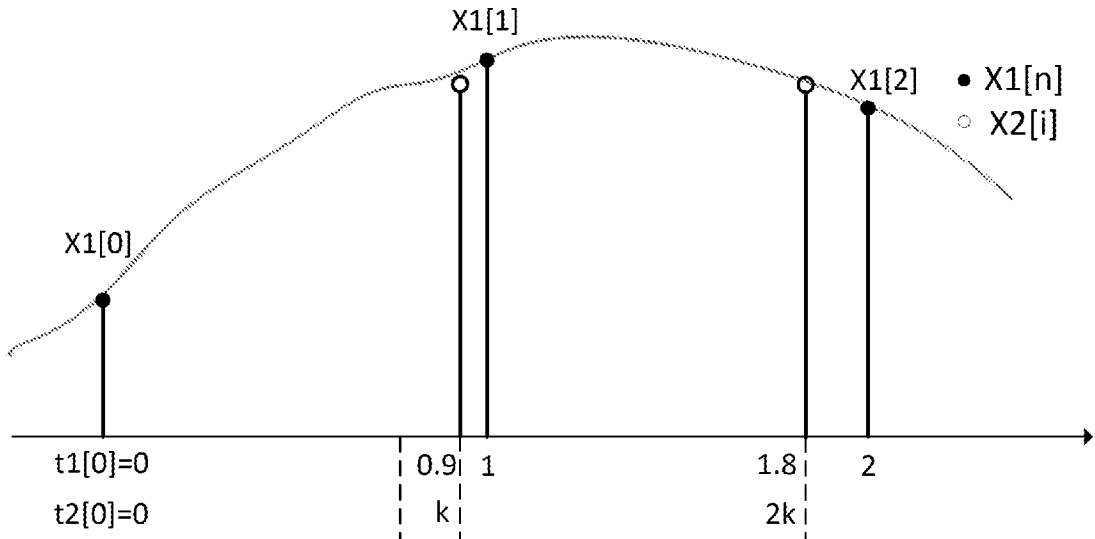

FIG. 5A

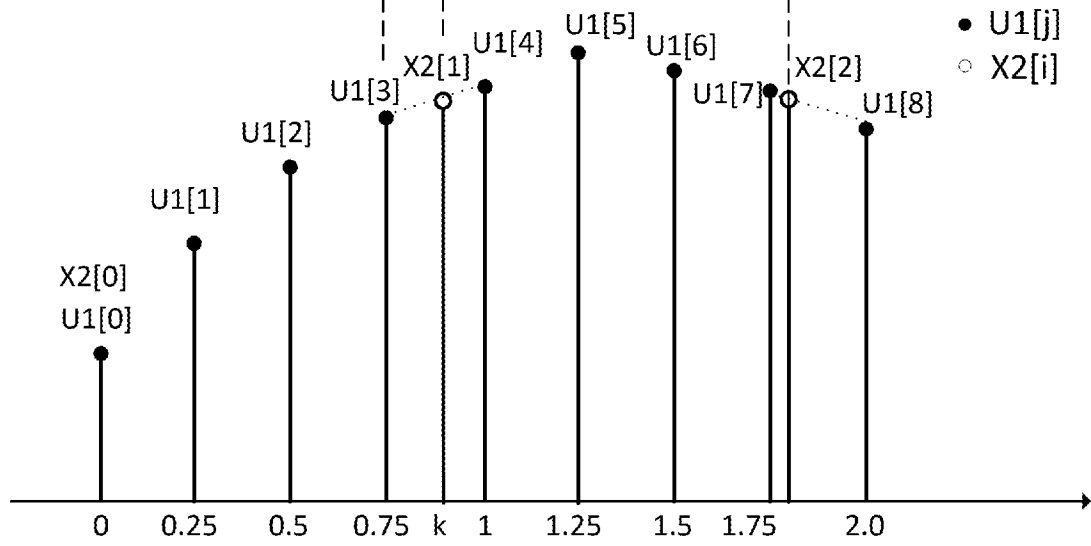

FIG. 5B

600

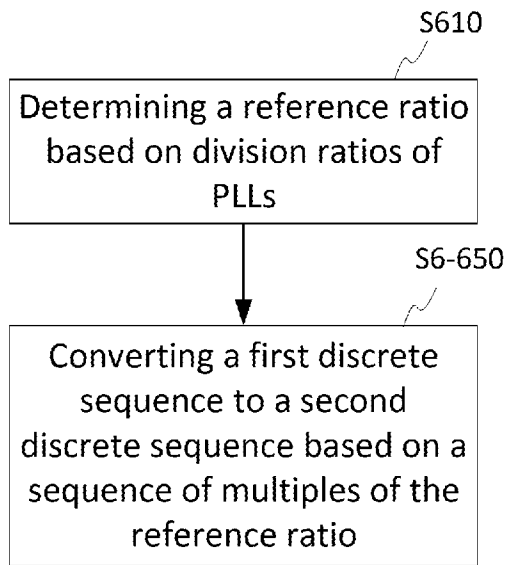

FIG. 6

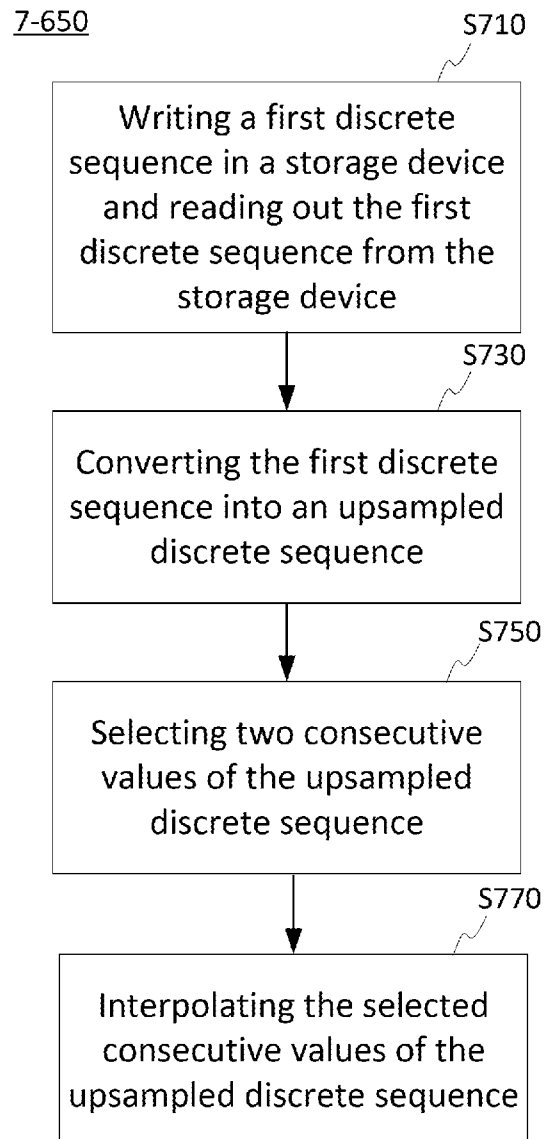

FIG. 7

## INTERNATIONAL SEARCH REPORT

International application No.  
**PCT/US2014/062057****A. CLASSIFICATION OF SUBJECT MATTER****H03L 7/06(2006.01)i, H03L 7/07(2006.01)i**

According to International Patent Classification (IPC) or to both national classification and IPC

**B. FIELDS SEARCHED**Minimum documentation searched (classification system followed by classification symbols)  
H03L 7/06; H03M 3/02; H03K 5/26; H03M 7/00; G06F 17/17; H03L 7/08; H03L 7/07Documentation searched other than minimum documentation to the extent that such documents are included in the fields searched  
Korean utility models and applications for utility models  
Japanese utility models and applications for utility modelsElectronic data base consulted during the international search (name of data base and, where practicable, search terms used)  
eKOMPASS(KIPO internal) & Keywords: sampling, converter, sequence, interpolation, buffer, oscillator, fraction, ratio**C. DOCUMENTS CONSIDERED TO BE RELEVANT**

Category*	Citation of document, with indication, where appropriate, of the relevant passages	Relevant to claim No.
Y	US 2010-0033220 A1 (GANG ZHANG) 11 February 2010 See paragraphs [0019]-[0043] and figures 1-4.	1-20
Y	US 6473475 B1 (BRUNO J. G. PUTZEYS) 29 October 2002 See column 1, lines 30-40, column 3, line 11-column 4, line 50 and figures 1-2.	1-20
A	US 2010-0085090 A1 (I-HSIANG LIN et al.) 08 April 2010 See abstract, paragraphs [0017]-[0041] and figures 1-5.	1-20
A	JP 2003-283338 A (MITSUBISHI ELECTRIC CORP.) 03 October 2003 See abstract, paragraphs [0021]-[0035] and figures 1-6.	1-20
A	US 2013-0038365 A1 (XIANG GAO et al.) 14 February 2013 See abstract, paragraphs [0039]-[0046], claim 1 and figures 7-11.	1-20

 Further documents are listed in the continuation of Box C. See patent family annex.

\* Special categories of cited documents:

"A" document defining the general state of the art which is not considered to be of particular relevance

"E" earlier application or patent but published on or after the international filing date

"L" document which may throw doubts on priority claim(s) or which is cited to establish the publication date of another citation or other special reason (as specified)

"O" document referring to an oral disclosure, use, exhibition or other means

"P" document published prior to the international filing date but later than the priority date claimed

"T" later document published after the international filing date or priority date and not in conflict with the application but cited to understand the principle or theory underlying the invention

"X" document of particular relevance; the claimed invention cannot be considered novel or cannot be considered to involve an inventive step when the document is taken alone

"Y" document of particular relevance; the claimed invention cannot be considered to involve an inventive step when the document is combined with one or more other such documents, such combination being obvious to a person skilled in the art

"&amp;" document member of the same patent family

Date of the actual completion of the international search

22 January 2015 (22.01.2015)

Date of mailing of the international search report

**23 January 2015 (23.01.2015)**

Name and mailing address of the ISA/KR



 International Application Division  
 Korean Intellectual Property Office  
 189 Cheongsu-ro, Seo-gu, Daejeon Metropolitan City, 302-701,  
 Republic of Korea

Facsimile No. ++82 42 472 3473

Authorized officer

KIM, Sung Gon

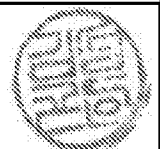
Telephone No. +82-42-481-8746





**INTERNATIONAL SEARCH REPORT**

Information on patent family members

International application No.

**PCT/US2014/062057**

Patent document cited in search report	Publication date	Patent family member(s)	Publication date
US 2010-0033220 A1	11/02/2010	CN 102113217 A	29/06/2011
		EP 2327161 A1	01/06/2011
		JP 05231643 B2	10/07/2013
		JP 2011-530882 A	22/12/2011
		KR 10-1247449 B1	25/03/2013
		KR 10-2011-0038734 A	14/04/2011
		TW 201012071 A	16/03/2010
		US 7759993 B2	20/07/2010
		WO 2010-017274 A1	11/02/2010
		US 6473475 B1	29/10/2002
EP 0998786 A2	10/05/2000		
JP 2002-506603 A	26/02/2002		
WO 99-56427 A2	04/11/1999		
WO 99-56427 A3	27/01/2000		
US 2010-0085090 A1	08/04/2010	CN 102177656 A	07/09/2011
		EP 2345163 A1	20/07/2011
		JP 2012-505609 A	01/03/2012
		KR 10-1268746 B1	04/06/2013
		KR 10-2011-0081837 A	14/07/2011
		TW 201034391 A	16/09/2010
		US 8145171 B2	27/03/2012
		WO 2010-042763 A1	15/04/2010
JP 2003-283338 A	03/10/2003	JP 03828031 B2	27/09/2006
		US 2003-0179116 A1	25/09/2003
		US 6873274 B2	29/03/2005
US 2013-0038365 A1	14/02/2013	US 8395427 B1	12/03/2013
		US 8427209 B2	23/04/2013