

(19)



(11)

**EP 1 728 087 B1**

(12)

**EUROPEAN PATENT SPECIFICATION**

(45) Date of publication and mention of the grant of the patent:  
**28.05.2008 Bulletin 2008/22**

(51) Int Cl.:  
**G01R 33/385 (2006.01) G01R 33/421 (2006.01)**

(21) Application number: **05708970.8**

(86) International application number:  
**PCT/IB2005/050844**

(22) Date of filing: **08.03.2005**

(87) International publication number:  
**WO 2005/091009 (29.09.2005 Gazette 2005/39)**

**(54) MAIN MAGNET PERFORATED EDDY CURRENT SHIELD FOR A MAGNETIC RESONANCE IMAGING DEVICE**

HAUPTMAGNET-PERFORATIONS-WIRBELSTROMABSCHIRMUNG FÜR EINE MAGNETRESONANZ-BILDGEBUNGSEINRICHTUNG

BLINDAGE CONTRE LES COURANTS DE FOUCAULT PERFORE POUR AIMANT PRINCIPAL DANS DISPOSITIF D'IMAGERIE PAR RESONANCE MAGNETIQUE

(84) Designated Contracting States:  
**AT BE BG CH CY CZ DE DK EE ES FI FR GB GR HU IE IS IT LI LT LU MC NL PL PT RO SE SI SK TR**

- **LA GRANGE, Martijn, R.**  
**NL-5656 AA Eindhoven (NL)**
- **BILOEN, David**  
**NL-5656 AA Eindhoven (NL)**

(30) Priority: **15.03.2004 EP 04101051**

(43) Date of publication of application:  
**06.12.2006 Bulletin 2006/49**

(74) Representative: **Cohen, Julius Simon**  
**Philips**  
**Intellectual Property & Standards**  
**P.O. Box 220**  
**5600 AE Eindhoven (NL)**

(73) Proprietor: **Koninklijke Philips Electronics N.V.**  
**5621 BA Eindhoven (NL)**

(72) Inventors:  
• **ROOZEN, Nicolaas, B.**  
**NL-5656 AA Eindhoven (NL)**

(56) References cited:  
**EP-A- 0 737 867 WO-A-99/28757**  
**US-A- 4 725 781 US-A- 5 028 872**

**EP 1 728 087 B1**

Note: Within nine months of the publication of the mention of the grant of the European patent in the European Patent Bulletin, any person may give notice to the European Patent Office of opposition to that patent, in accordance with the Implementing Regulations. Notice of opposition shall not be deemed to have been filed until the opposition fee has been paid. (Art. 99(1) European Patent Convention).

## Description

**[0001]** The present invention relates to a magnetic resonance imaging device, comprising at least a main magnet system for generating a steady magnetic field in a measuring space of the magnetic resonance imaging device, a gradient system for generating a magnetic gradient field in said measuring space, and an eddy current shield system.

**[0002]** US 5,028,872 discloses a magnetic resonance imaging (MRI) system, which includes a main shield member arranged in the cylindrical housing; and a sub shield member which is electrically connected to the main shield member and is arranged outside the housing to cover a region where the object under examination is placed.

**[0003]** The basic components of a magnetic resonance imaging (MRI) device are the main magnet system, the gradient system, the RF system and the signal processing system. The main magnet system is also often called cryostat. The main magnet system comprises a bore hole defining a measuring space and enabling the entry of an object to be analyzed by the MRI device. The main magnet system generates a strong uniform static field for polarization of nuclear spins in the object to be analyzed. The gradient system is designed to produce time-varying magnetic fields of controlled spatial non-uniformity. The gradient system is a crucial part of the MRI device because gradient fields are essential for signal localization. The RF system mainly consists of a transmitter coil and a receiver coil, wherein the transmitter coil is capable of generating a magnetic field for excitation of a spin system, and wherein the receiver coil converts a precessing magnetization into electrical signals. The signal processing system generates images on basis of the electrical signals.

**[0004]** Magnetic resonance imaging (MRI) devices known from prior art usually generate a relatively high acoustic noise level which has to be minimized. On the one hand, acoustic noise is caused by vibrations of the gradient system, and on the other hand acoustic noise is caused by vibrations of the main magnet system (cryostat).

**[0005]** The acoustic noise generated by the gradient system vibrations can effectively be reduced by means of a vacuum chamber. See for example US 6,404,200 and US 5,793,210.

**[0006]** In order to further reduce the acoustic noise of the MRI devices, the acoustic noise generated by the vibrating main magnet system needs to be reduced. The main magnet system vibrations are caused by three excitation mechanisms, firstly by a structural transmission of vibrations from the gradient system to the main magnet system through gradient coil mounts, secondly by a magnetic excitation of the main magnet system due to the varying magnetic gradient-fields causing eddy currents in the wall of the main magnet system, and thirdly by an acoustic excitation of the main magnet system. The third

excitation mechanism is not dominant for most MRI devices.

**[0007]** The first excitation mechanism causing vibrations of the main magnet system can be reduced effectively by using a compliant support for the gradient coils of the gradient system. See for example EP-A-1 193 507.

**[0008]** From US 6,326,788 it is known that the magnetic excitation of the main magnet system can effectively be reduced by means of an eddy current shield system mounted rigidly on the gradient system. However, it is difficult to reduce eddy currents in the flange of the main magnet system by means of an eddy current shield system mounted on the gradient system.

**[0009]** From EP-A-1 193 507 it is known that the magnetic excitation of the main magnet system can effectively be reduced by using a non-conducting main magnet system. This has however drawbacks with respect to a boil-off effect, because heat is generated inside the main magnet system as a result of the fact that the main magnet system is non-conducting.

**[0010]** It is an object of the present invention to provide a magnetic resonance imaging device in which vibrations and acoustic noise caused by said second excitation mechanism, namely by the magnetic excitation of the main magnet system due to the varying magnetic gradient-fields causing eddy currents in the wall of the main magnet system, are reduced in an alternative way.

**[0011]** In order to achieve said object, a magnetic resonance imaging device in accordance with the invention is characterized in that the or each perforated eddy current screen is flexibly connected to the main magnet system.

**[0012]** Preferably, the or each perforated eddy current screen is designed in a way that the degree of perforation is in the range of 0.1% to 95%, most preferably in the range of 10% to 50%.

**[0013]** In accordance with a preferred embodiment of the present invention the or each perforated eddy current screen is designed as a constraining layer structure, wherein the constraining layer structure comprises preferably two perforated plate-like layers, especially made from copper, and one perforated visco-elastic layer made from a visco-elastic material. The visco-elastic layer is sandwiched between the two plate-like layers.

**[0014]** Embodiments of a magnetic resonance imaging device in accordance with the invention will be described in detail hereafter with reference to the drawings, in which

Fig. 1 shows an MRI device according to the prior art; Fig. 2 shows a view onto a lateral flange of an MRI device according to a first embodiment of the present invention;

Fig. 3 shows a cross-sectional view through the MRI device according to the first embodiment of the present invention along the line of intersection III-III in Fig. 2;

Fig. 4 shows the detail IV according to Fig. 3;

Fig. 5 shows the detail V according to Fig. 2;

Fig. 6 shows a partial cross-sectional view through a MRI device according to a second embodiment of the present invention; and

Fig. 7 shows a partial cross-sectional view through a MRI device according to a third embodiment of the present invention.

**[0015]** Figure 1 shows a magnetic resonance imaging (MRI) device 1 known from prior art which includes a main magnet system 2 for generating a steady magnetic field, and also several gradient coils providing a gradient system 3 for generating additional magnetic fields having a gradient in the X, Y, Z directions. The Z direction of the coordinate system shown corresponds to the direction of the steady magnetic field in the main magnet system 2 by convention. The Z axis is an axis co-axial with the axis of a bore hole of the main magnet system 2, wherein the X axis is the vertical axis extending from the center of the magnetic field, and wherein the Y axis is the corresponding horizontal axis orthogonal to the Z axis and the X axis.

**[0016]** The gradient coils of the gradient system 3 are fed by a power supply unit 4. An RF transmitter coil 5 serves to generate RF magnetic fields and is connected to an RF transmitter and modulator 6. A receiver coil is used to receive the magnetic resonance signal generated by the RF field in the object 7 to be examined, for example a human or animal body. This coil may be the same coil as the RF transmitter coil 5. Furthermore, the main magnet system 2 encloses an examination space which is large enough to accommodate a part of the body 7 to be examined. The RF coil 5 is arranged around or on the part of the body 7 to be examined in this examination space. The RF transmitter coil 5 is connected to a signal amplifier and demodulation unit 10 via a transmission/reception circuit 9.

**[0017]** The control unit 11 controls the RF transmitter and modulator 6 and the power supply unit 4 so as to generate special pulse sequences which contain RF pulses and gradients. The phase and amplitude obtained from the demodulation unit 10 are applied to a processing unit 12. The processing unit 12 processes the presented signal values so as to form an image by transformation. This image can be visualized, for example by means of a monitor 8.

**[0018]** The present invention provides a passive shielding to reduce the acoustic noise level generated by magnetic resonance imaging devices due to the magnetic excitation of the main magnet system due the varying magnetic gradient-fields causing eddy currents in the wall of the main magnet system. According to the present invention, the magnetic resonance imaging device comprises an eddy current shield system, wherein the eddy current shield system comprises at least one perforated eddy current screen, and wherein the or each perforated eddy current screen is preferably flexibly connected to the main magnet system.

**[0019]** In the embodiment shown in figures 2 and 3, the magnetic resonance imaging device 1 comprises two eddy current screens 13, 14, wherein at each lateral flange 15, 16 of the main magnet system 2 there is positioned one of said eddy current screens 13, 14.

**[0020]** As already mentioned above, the eddy current screens 13, 14 are designed as perforated eddy current screens. In order to provide good shielding properties of the eddy current screens 13, 14, the degree of perforation should be as low as possible. However, in order to provide good acoustic properties, the degree of perforation should be as high as possible. A high degree of perforation reduces the acoustic radiation of the vibrating eddy current screens 13, 14. It should be noted, that the vibrations of the eddy current screens 13, 14 are caused by eddy currents in the eddy current screens 13, 14 that cause Lorentz forces acting upon the eddy current screens 13, 14.

**[0021]** According to the present invention, the perforated eddy current screens 13, 14 are designed in a way that the degree of perforation is in the range of 0.1 % to 95%, preferably in the range of 10% to 50%. Especially the range of 10% to 50% provides a good compromise between the required shielding properties and acoustic properties of the eddy current screens 13, 14.

**[0022]** Figure 5 shows the enlarged detail V according to figure 2 and illustrates the perforated structure of the eddy current screens 13, 14. The eddy current screens 13, 14 are designed as plate-like elements, a plurality of holes 17 being formed into the plate-like elements of the eddy current screens 13, 14. In the most preferred embodiment, the degree of perforation is approximately 30 %. This would mean that the hole-area of the eddy current screens 13, 14 is approximately 30 % of the total area of the eddy current screens 13, 14.

**[0023]** The eddy current screens 13, 14 are characterized by a thickness being thin enough or small enough in order to minimize radiation of acoustic noise and being thick enough in order to shield the magnetic field radiated by the gradient coils of the gradient system 3 effectively. In order to minimize the radiation of acoustic noise by the eddy current screens 13, 14, the critical frequency  $f_c$  of the eddy current screens 13, 14 should be greater than the frequency of the acoustic noise generated by the magnetic imaging device 1. Magnet resonance imaging devices generate usually acoustic noise dominated around 1000 Hz, ranging from 500 Hz to 2000 Hz. The critical frequency  $f_c$  can be calculated from the formula:

$$f_c = \frac{(c_a)^2}{\pi h} \sqrt{\frac{3\rho}{E}}$$

wherein  $C_a$  is the speed of sound in air, wherein  $\rho$  is the density of the material of the eddy current screens 13, 14, wherein E is the Young's modulus of the material of

the eddy current screens 13, 14 and wherein h is the thickness of the eddy current screens 13, 14.

[0024] In order to provide good magnetic shielding properties of the eddy current screens 13, 14, the skin depth of the eddy current screens 13, 14 should be in a range that magnetic fields for frequencies of 500 Hz and higher are sufficiently shielded. The skin depth can be calculated with the formula:

$$\delta = \sqrt{\frac{2}{\mu\mu_0\sigma 2\pi f}}$$

wherein  $\delta$  is the skin depth,  $\mu$  is the relative permeability,  $\mu_0$  is the permeability of the material from which the eddy current screens 13, 14 are made, wherein  $\sigma$  is the conductivity of the material from which the eddy current screens 13, 14 are made and wherein  $f$  is the frequency of the magnetic field to be shielded. The thickness of the eddy current screens 13, 14 should be in the range of the skin depth, or larger, in order to provide sufficient magnetic shielding.

[0025] Considering the above mentioned criterias the perforated eddy current screens 13, 14 are preferably made from copper having a density of  $\rho = 8960 \text{ kg/m}^3$ , a Young's modulus  $E = 123 \times 10^9 \text{ N/m}^2$ , and a conductivity of  $\sigma = 5,8 \times 10^7 \text{ 1}/\Omega \times \text{m}$ . It is also possible to provide eddy current screens 13, 14 made from Aluminium.

[0026] The thickness of the perforated eddy current screens 13, 14 made from copper are characterized by a thickness in the range of 0,01 mm to 10 mm, preferably in the range of 1 mm to 5 mm. Most preferably the eddy current screens 13, 14 have a thickness of 3 mm.

[0027] As shown in figure 4, the thickness of the eddy current screens 13, 14 is increased in the region in which the eddy current screens 13, 14 are mounted to the main magnet system 2. In these locations, the eddy current screens 13, 14 preferably have a thickness of approximately 8 mm. With the increased thickness of the eddy current screens 13, 14 at the mounting locations, it is possible to improve the isolation of the eddy current screens 13, 14 from the main magnet system 2. An alternative way to improve the isolation is to use an extra mass on the eddy current screens 13, 14 in the region of the mounting locations.

[0028] It should be noted that the eddy current screens 13, 14 are flexibly connected to the main magnet system 2 by elastic mounting means 18. The elastic mounting means 18 are preferably designed as flexible rubber means.

[0029] According to a further improved embodiment of the present invention, the eddy current screens 13, 14 are designed as constraining layer structures figure 4 shows a constraining layer structure of the eddy current screen 13 comprising two plate-like layers 19, 20 preferably made from copper and one visco-elastic layer 21

sandwiched between the two plate-like layers 19, 20. It should be noted that the two plate-like layers 19, 20 and the visco-elastic layer 21 are all perforated according to the present invention. Such a constraining layer structure provides a high amount of the structural damping, and thus a reduced vibration level of the perforated eddy current screen.

[0030] Within the embodiment shown in figures 2 and 3, the eddy current screens 13, 14 are positioned in the region of the two lateral flanges 15, 16 of the main magnet system 2. With such an arrangement it is possible to reduce the eddy currents in the flanges 15, 16 of the main magnet system 2.

[0031] Figure 6 shows a modification of the present invention in which the eddy current screens 13, 14 extend into the bore hole of the main magnet system 2. Within the embodiment of figure 6 the eddy current screens 13, 14 shield the lateral flanges 15, 16 of the main magnet system 2 and in addition the outer ends of the bore hole.

[0032] Within the embodiment shown in figure 7 the eddy current screens 13, 14 shield both lateral flanges 15, 16 of the main magnet system 2 and the complete bore hole. Within the embodiment of figure 7 the eddy current screens 13, 14 are positioned in the region of the two lateral flanges 15, 16 of the main magnet system 2 and in addition in the region of the bore hole, within the bore hole the eddy current screens being positioned between the main magnet system 2 and the gradient system 3.

[0033] It is also possible to have the eddy current screens located only in the region of the bore hole of the main magnet system.

[0034] The present invention provides a magnetic resonance imaging device with a eddy current shield system comprising at least one perforated eddy current screen. With such a perforated eddy current screen the acoustic noise caused by the magnetic excitation of the main magnet system due to the varying magnetic gradient-fields can be efficiently shielded. Perforated eddy current screens provide a passive shielding mechanism.

## Claims

1. A magnetic resonance imaging device, comprising at least:
  - a) a main magnet system (2) for generating a steady magnetic field in a measuring space of the magnetic resonance imaging device;
  - b) a gradient system (3) for generating a magnetic gradient field in said measuring space; and
  - c) an eddy current shield system that comprises at least one perforated eddy current screen (13, 14), **characterized in that** the or each perforated eddy current screen (13, 14) is flexibly connected to the main magnet system (2).

2. A magnetic resonance imaging device according to claim 1, **characterized in that** the or each perforated eddy current screen (13, 14) is designed in a way that the degree of perforation is in the range of 0.1% to 95%.
3. A magnetic resonance imaging device according to claim 2, **characterized in that** the or each perforated eddy current screen (13, 14) is designed in a way that the degree of perforation is in the range of 10% to 50%.
4. A magnetic resonance imaging device according to claim 1, **characterized in that** the or each perforated eddy current screen (13, 14) is designed as a constraining layer structure, wherein the constraining layer structure comprises at least one perforated plate-like layer (19, 20) and at least one perforated visco-elastic layer (21).
5. A magnetic resonance imaging device according to claim 4, **characterized in that** the constraining layer structure comprises two perforated plate-like layers (19, 20) and one perforated visco-elastic layer (21), wherein the visco-elastic layer (21) is sandwiched between the two plate-like layers (19, 20).
6. A magnetic resonance imaging device according to claim 1, **characterized in that** the or each eddy current screen (13, 14) has a thickness being thin enough to minimize radiation of acoustic noise and being thick enough to maximize shielding against the magnetic field radiated by the gradient system (3).
7. A magnetic resonance imaging device according to claim 6, **characterized in that** the or each eddy current screen (13, 14) has a thickness in the range of 0.01 mm to 10 mm.
8. A magnetic resonance imaging device according to claim 7, **characterized in that** the or each eddy current screen (13, 14) has a thickness in the range of 1 mm to 5 mm.
9. A magnetic resonance imaging device according to claim 6, **characterized in that** the or each eddy current screen (13, 14) has an increased thickness in the region in which the eddy current screen (13, 14) is mounted to the main magnet system (2).
10. A magnetic resonance imaging device according to claim 1, **characterized in that** the or each eddy current screen (13, 14) is flexibly attached to the main magnet system (2) by elastic mounting means (18), especially by flexible rubber means.
11. A magnetic resonance imaging device according to

claim 1, **characterized in that** the or each eddy current screen (13, 14) is positioned at least in the region of the two lateral flanges (15, 16) of the main magnet system (2).

5

12. A magnetic resonance imaging device according to claim 11, **characterized in that** the or each eddy current screen (13, 14) is positioned in the region of the lateral flanges (15, 16) of the main magnet system (2) and in addition in the region of the bore hole between the main magnet system (2) and the gradient system (3).

10

15

13. A magnetic resonance imaging device according to claim 1, **characterized in that** the or each eddy current screen (13, 14) is positioned at least in the region of the bore hole between the main magnet system (2) and the gradient system (3).

20

25

14. A magnetic resonance imaging device according to claim 13, **characterized in that** the or each eddy current screen (13, 14) is positioned in the region of the bore hole and in addition in the region of the lateral flanges (15, 16) of the main magnet system (2).

#### Patentansprüche

30

1. Magnetresonanz-Bildgebungseinrichtung, die mindestens Folgendes umfasst:

35

a) ein Hauptmagnetsystem (2) zum Erzeugen eines stationären Magnetfelds in einem Messraum der Magnetresonanz-Bildgebungseinrichtung;

b) ein Gradientensystem (3) zum Erzeugen eines magnetischen Gradientenfeldes in dem genannten Messraum; und

40

c) ein Wirbelstromabschirmungssystem, das mindestens eine perforierte Wirbelstromabschirmung (13, 14) umfasst, **dadurch gekennzeichnet, dass** die oder jede perforierte Wirbelstromabschirmung (13, 14) flexibel mit dem Hauptmagnetsystem (2) verbunden ist.

45

2. Magnetresonanz-Bildgebungseinrichtung nach Anspruch 1, **dadurch gekennzeichnet, dass** die oder jede perforierte Wirbelstromabschirmung (13, 14) auf eine solche Weise entworfen ist, dass der Perforationsgrad im Bereich von 0,1 % bis 95 % liegt.

50

3. Magnetresonanz-Bildgebungseinrichtung nach Anspruch 2, **dadurch gekennzeichnet, dass** die oder jede perforierte Wirbelstromabschirmung (13, 14) auf eine solche Weise entworfen ist, dass der Perforationsgrad im Bereich von 10 % bis 50 % liegt.

55

4. Magnetresonanz-Bildgebungseinrichtung nach Anspruch 1, **dadurch gekennzeichnet, dass** die oder jede perforierte Wirbelstromabschirmung (13, 14) als eine begrenzende Schichtstruktur entworfen ist, wobei die begrenzende Schichtstruktur mindestens eine perforierte, plattenartige Schicht (19, 20) und mindestens eine perforierte viskoelastische Schicht (21) umfasst.
5. Magnetresonanz-Bildgebungseinrichtung nach Anspruch 4, **dadurch gekennzeichnet, dass** die begrenzende Schichtstruktur zwei perforierte plattenartige Schichten (19, 20) und eine perforierte viskoelastische Schicht (21) umfasst, wobei die viskoelastische Schicht (21) zwischen die beiden plattenartigen Schichten (19, 20) eingefügt ist.
6. Magnetresonanz-Bildgebungseinrichtung nach Anspruch 1, **dadurch gekennzeichnet, dass** die oder jede Wirbelstromabschirmung (13, 14) eine Dicke hat, die ausreichend gering ist, um die Strahlung von akustischem Rauschen zu reduzieren, und ausreichend groß ist, um die Abschirmung gegen das durch das Gradientensystem (3) abgestrahlte Magnetfeld zu maximieren.
7. Magnetresonanz-Bildgebungseinrichtung nach Anspruch 6, **dadurch gekennzeichnet, dass** die oder jede Wirbelstromabschirmung (13, 14) eine Dicke im Bereich von 0,01 mm bis 10 mm hat.
8. Magnetresonanz-Bildgebungseinrichtung nach Anspruch 7, **dadurch gekennzeichnet, dass** die oder jede Wirbelstromabschirmung (13, 14) eine Dicke im Bereich von 1 mm bis 5 mm hat.
9. Magnetresonanz-Bildgebungseinrichtung nach Anspruch 6, **dadurch gekennzeichnet, dass** die oder jede Wirbelstromabschirmung (13, 14) eine erhöhte Dicke in der Region hat, in der die Wirbelstromabschirmung (13, 14) an dem Hauptmagnetsystem (2) angebracht ist.
10. Magnetresonanz-Bildgebungseinrichtung nach Anspruch 1, **dadurch gekennzeichnet, dass** die oder jede Wirbelstromabschirmung (13, 14) über elastische Befestigungsmittel 18, speziell über flexible Gummimittel, flexibel mit dem Hauptmagnetsystem (2) verbunden ist.
11. Magnetresonanz-Bildgebungseinrichtung nach Anspruch 1, **dadurch gekennzeichnet, dass** die oder jede Wirbelstromabschirmung (13, 14) mindestens in der Region der beiden lateralen Flansche (15, 16) des Hauptmagnetsystems (2) angeordnet ist.
12. Magnetresonanz-Bildgebungseinrichtung nach Anspruch 11, **dadurch gekennzeichnet, dass** die

oder jede Wirbelstromabschirmung (13, 14) in der Region der lateralen Flansche (15, 16) des Hauptmagnetsystems (2) und zusätzlich in der Region der röhrenförmigen Öffnung zwischen dem Hauptmagnetsystem (2) und dem Gradientensystem (3) angeordnet ist.

13. Magnetresonanz-Bildgebungseinrichtung nach Anspruch 1, **dadurch gekennzeichnet, dass** die oder jede Wirbelstromabschirmung (13, 14) mindestens in der Region der röhrenförmigen Öffnung zwischen dem Hauptmagnetsystem (2) und dem Gradientensystem (3) angeordnet ist.

14. Magnetresonanz-Bildgebungseinrichtung nach Anspruch 13, **dadurch gekennzeichnet, dass** die oder jede Wirbelstromabschirmung (13, 14) in der Region der röhrenförmigen Öffnung und zusätzlich in der Region der lateralen Flansche (15, 16) des Hauptmagnetsystems (2) angeordnet ist.

#### Revendications

1. Dispositif d'imagerie par résonance magnétique, comprenant au moins:
- a) un système d'aimant principal (2) pour générer un champ magnétique constant dans un espace de mesure du dispositif d'imagerie par résonance magnétique,
  - b) un système de gradients (3) pour générer un champ de gradient magnétique dans ledit espace de mesure; et
  - c) un système de blindage contre les courants de Foucault qui comprend au moins un écran perforé (13, 14) pour courants de Foucault, **caractérisé en ce que** l'écran perforé ou chaque écran perforé (13, 14) pour courants de Foucault est relié de façon flexible au système d'aimant principal (2).
2. Dispositif d'imagerie par résonance magnétique suivant la revendication 1, **caractérisé en ce que** l'écran perforé ou chaque écran perforé (13, 14) pour courants de Foucault est conçu d'une manière telle que le degré de perforation soit situé dans l'intervalle de 0,1% à 95%.
3. Dispositif d'imagerie par résonance magnétique suivant la revendication 2, **caractérisé en ce que** l'écran perforé ou chaque écran perforé (13, 14) pour courants de Foucault est conçu d'une manière telle que le degré de perforation soit situé dans l'intervalle de 10% à 50%.
4. Dispositif d'imagerie par résonance magnétique suivant la revendication 1, **caractérisé en ce que**

- l'écran perforé ou chaque écran perforé (13, 14) pour courants de Foucault est conçu comme une structure de contrainte multicouche, ladite structure de contrainte multicouche comprenant au moins une couche du type plaque perforée (19, 20) et au moins une couche viscoélastique perforée (21).
- 5
5. Dispositif d'imagerie par résonance magnétique suivant la revendication 4, **caractérisé en ce que** la structure de contrainte multicouche comprend deux couches du type plaque perforée (19, 20) et une couche viscoélastique perforée (21), ladite couche viscoélastique (21) étant prise en sandwich entre les deux couches du type plaque (19, 20).
- 10
6. Dispositif d'imagerie par résonance magnétique suivant la revendication 1, **caractérisé en ce que** l'écran ou chaque écran (13, 14) pour courants de Foucault a une épaisseur qui est suffisamment mince pour minimaliser le rayonnement du bruit acoustique et suffisamment épaisse pour maximaliser le blindage contre le champ magnétique rayonné par le système de gradients (3).
- 15
7. Dispositif d'imagerie par résonance magnétique suivant la revendication 6, **caractérisé en ce que** l'écran ou chaque écran pour courants de Foucault (13, 14) a une épaisseur comprise située dans l'intervalle de 0,01 mm à 10 mm.
- 20
8. Dispositif d'imagerie par résonance magnétique suivant la revendication 7, **caractérisé en ce que** l'écran ou chaque écran pour courants de Foucault (13, 14) a une épaisseur située dans l'intervalle de 1 mm à 5 mm.
- 25
9. Dispositif d'imagerie par résonance magnétique suivant la revendication 6, **caractérisé en ce que** l'écran ou chaque écran pour courants de Foucault (13, 14) a une épaisseur accrue dans la région dans laquelle l'écran pour courants de Foucault (13, 14) est monté sur le système d'aimant principal (2).
- 30
10. Dispositif d'imagerie par résonance magnétique suivant la revendication 1, **caractérisé en ce que** l'écran ou chaque écran pour courants de Foucault (13, 14) est fixé de manière flexible au système d'aimant principal (2) par des moyens de montage élastiques (18), spécialement par des moyens en caoutchouc souples.
- 35
11. Dispositif d'imagerie par résonance magnétique suivant la revendication 1, **caractérisé en ce que** l'écran ou chaque écran pour courants de Foucault (13, 14) est positionné au moins dans la région des deux joues latérales (15, 16) du système d'aimant principal (2).
- 40
12. Dispositif d'imagerie par résonance magnétique suivant la revendication 11, **caractérisé en ce que** l'écran ou chaque écran pour courants de Foucault (13, 14) est positionné dans la région des joues latérales (15, 16) du système d'aimant principal (2) et, en outre, dans la région du tunnel entre le système d'aimant principal (2) et le système de gradients (3).
- 45
13. Dispositif d'imagerie par résonance magnétique suivant la revendication 1, **caractérisé en ce que** l'écran ou chaque écran pour courants de Foucault (13, 14) est positionné au moins dans la région du tunnel entre le système d'aimant principal (2) et le système de gradients (3).
- 50
14. Dispositif d'imagerie par résonance magnétique suivant la revendication 13, **caractérisé en ce que** l'écran ou chaque écran pour courants de Foucault (13, 14) est positionné dans la région du tunnel et, en outre, dans la région des joues latérales (15, 16) du système d'aimant principal (2).
- 55

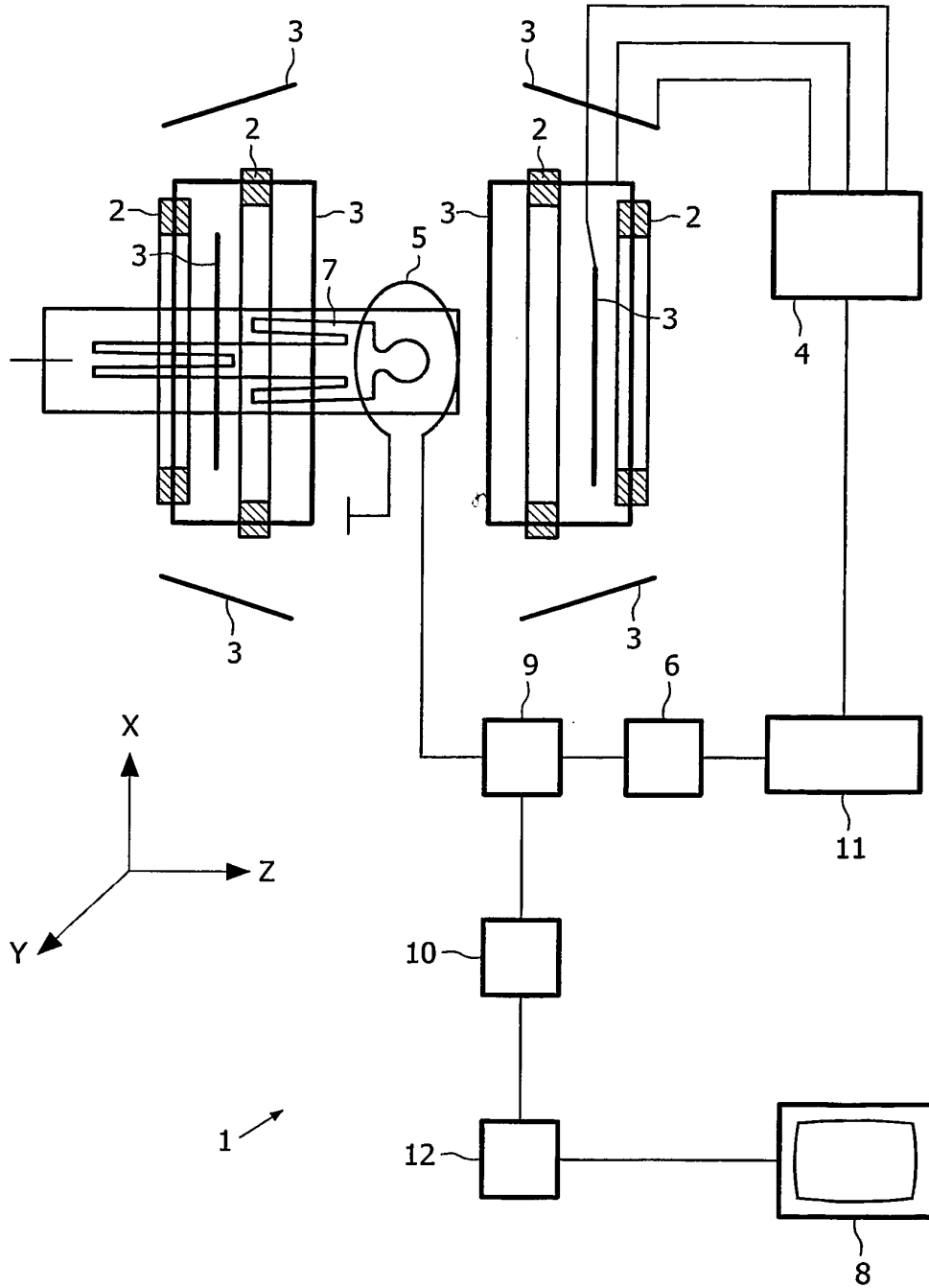

FIG. 1

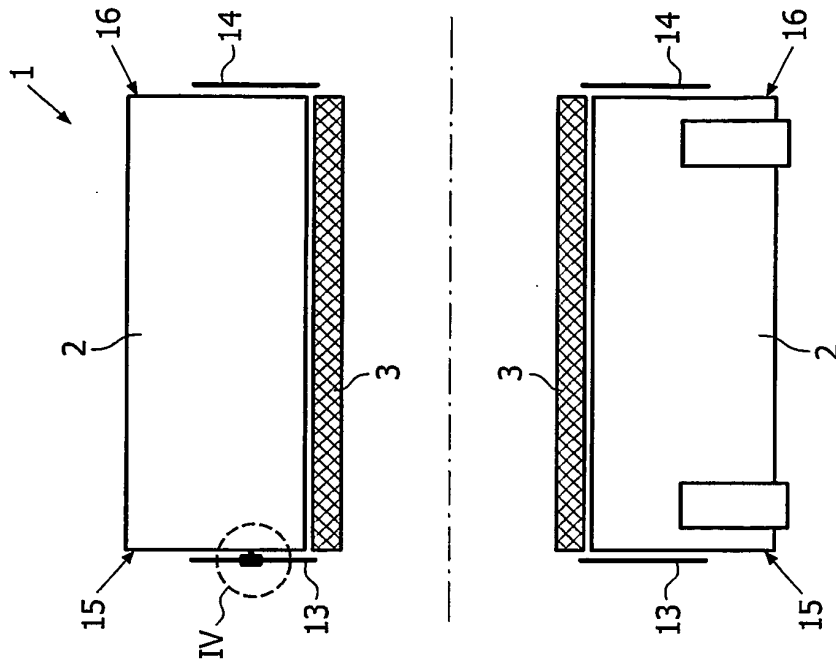

FIG. 3

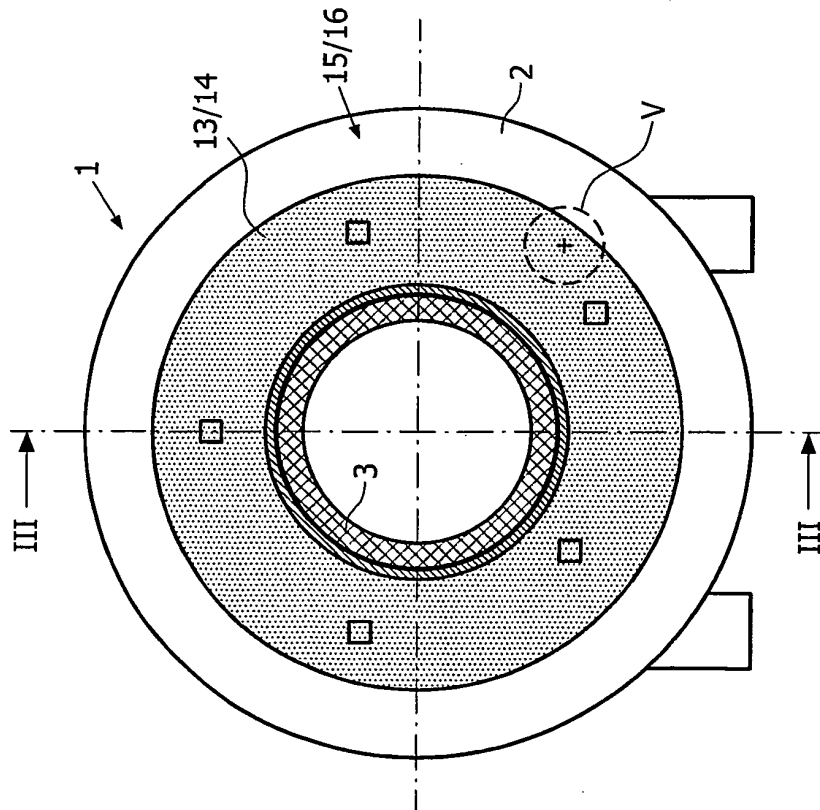

FIG. 2

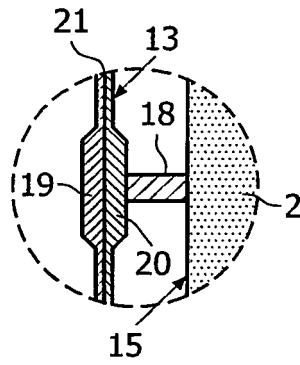

FIG. 4

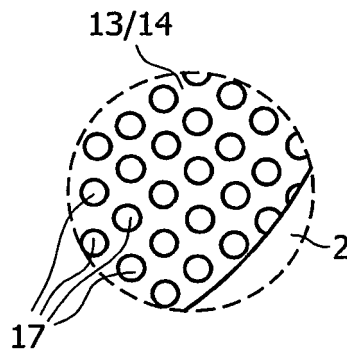

FIG. 5

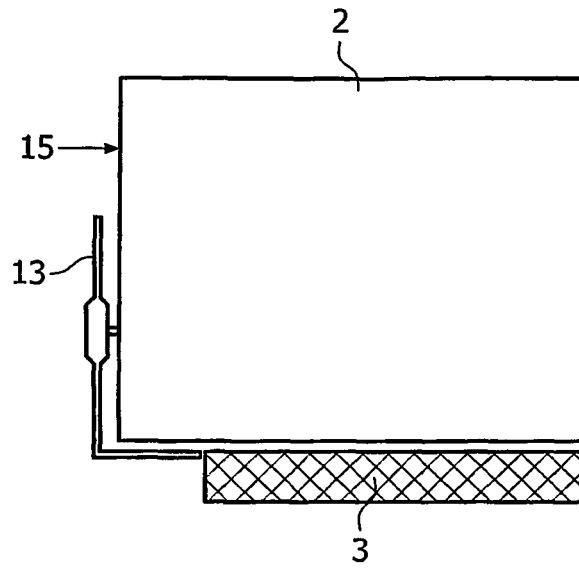

FIG. 6

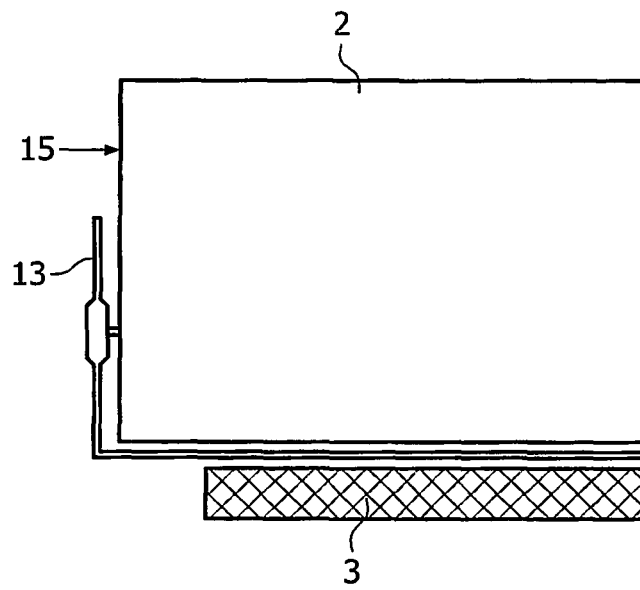

FIG. 7

**REFERENCES CITED IN THE DESCRIPTION**

*This list of references cited by the applicant is for the reader's convenience only. It does not form part of the European patent document. Even though great care has been taken in compiling the references, errors or omissions cannot be excluded and the EPO disclaims all liability in this regard.*

**Patent documents cited in the description**

- US 5028872 A [0002]
- US 6404200 B [0005]
- US 5793210 A [0005]
- EP 1193507 A [0007] [0009]
- US 6326788 B [0008]