

Dec. 18, 1956

A. F. BECKER

2,774,586

FLOOR SCRAPING MACHINE HAVING FLOATING SCRAPER

Filed June 14, 1954

2 Sheets-Sheet 1

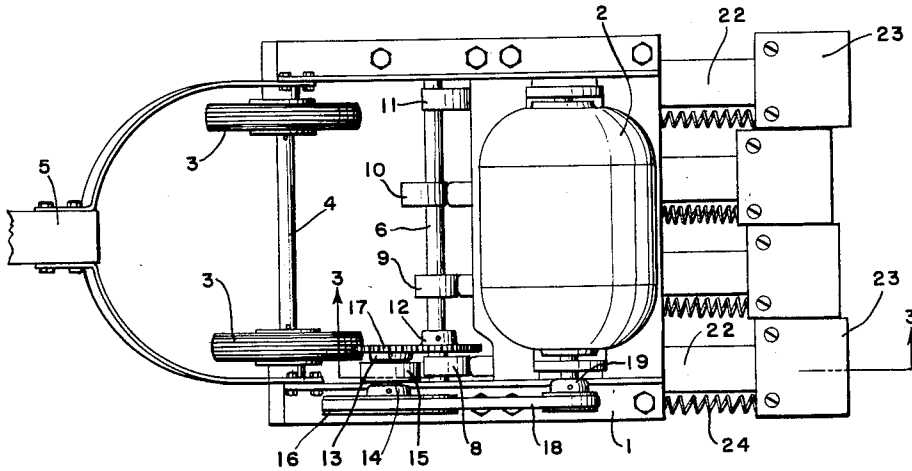

FIG. 1

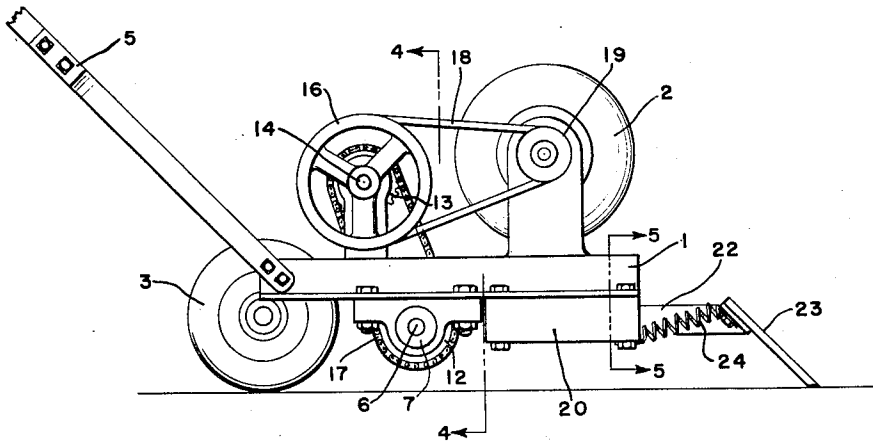

FIG. 2

INVENTOR.
ANTHONY F. BECKER

BY

Ramsden O. Wyatt

ATTORNEY

Dec. 18, 1956

A. F. BECKER

2,774,586

FLOOR SCRAPING MACHINE HAVING FLOATING SCRAPER

Filed June 14, 1954

2 Sheets-Sheet 2

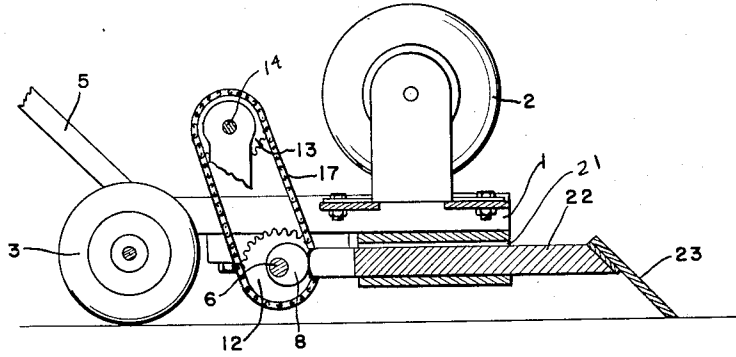

FIG. 3

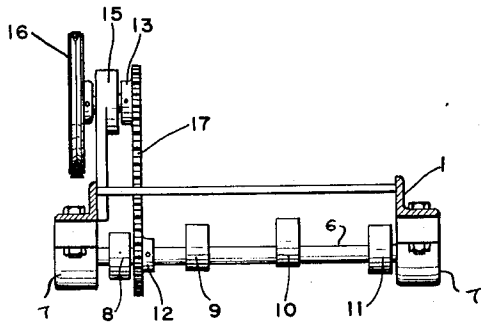

FIG. 4

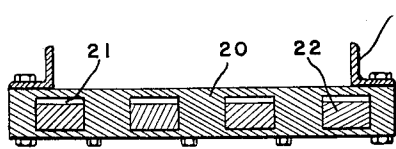

FIG. 5

INVENTOR.
ANTHONY F. BECKER

BY *Russell O. Whyatt*

ATTORNEY

1

2,774,586

FLOOR SCRAPING MACHINE HAVING FLOATING SCRAPER

Anthony F. Becker, Houston, Tex., assignor to The American Floor Surfacing Machine Company, Toledo, Ohio, a corporation of Ohio

Application June 14, 1954, Serial No. 436,510

9 Claims. (Cl. 262-8)

This invention relates to new and useful improvements in a floor scraping machine.

It is an object of this invention to provide a floor scraping machine for cleaning floors, such as are used in removing floor coverings, such as tile, linoleum and the like.

It is another object of this invention to provide a floor covering removing machine for use on floors that will enable the operator to clean a floor close to the walls of the room and in the corners of the room.

It is another object of the invention to provide a floor cleaning machine of light weight and few working parts that will be inexpensive to manufacture and easy to assemble and operate, and that may be useful in any floor cleaning operation.

It is still another object of the invention to provide a floor covering removing machine that will have means for yielding to the contours of the floor and thus removing the covering without damage to the floor.

With the above and other objects in view, the invention has relation to certain novel features of construction and operation more particularly defined in the following specifications and illustrated in the accompanying drawing, wherein:

Figure 1 is a top plan view of the device.

Figure 2 is a side elevational view.

Figure 3 is a side elevational sectional view, taken on the line 3-3 of Figure 1.

Figure 4 is a front elevational sectional view taken on the line 4-4 of Figure 2, and

Figure 5 is a front elevational view, in section, taken on the line 5-5 of Figure 2.

Referring now more particularly to the drawings, the numeral 1 designates a framework, which may be formed of any suitable material, such as steel or the like, and which forms a platform and support for a suitable power means, as the electric motor 2. Suitable means of mobilizing the platform are provided, such as the wheels 3, 3 which are joined by an axle 4, which extends between the side members of the framework 1. A suitable handle, as 5, may be provided, which is anchored to the framework 1.

A cam shaft 6 is transversely mounted on the framework 1 and rotates on suitable bearings 7 in the framework. Staggered eccentric cams, as 8, 9, 10, 11, are mounted on the cam shaft 6. A rotated gear, such as the toothed gear 12, is mounted on the cam shaft 6. A rotated gear 13 is mounted on the axle 14, which is in turn mounted in the bearing 15. A pulley 16 is mounted on the other end of the axle 14. Suitable connecting means, such as the chain 17, imparts rotation from the gear 13 to the gear 12 and suitable connecting means, such as the V-belt 18 imparts rotation from the motor pulley 19 to the pulley 16.

A cutter arm housing 20 is formed on the framework 1 through which a series of transverse cutter arm channels 21 are formed. The channels 21 are positioned directly opposite the respective cams 8, 9, 10, 11 and

2

cutter arms 22 are mounted in said channels 21 and the arms 22 are formed to fit loosely in said channels 21, the channels being sufficiently larger that the arms to permit easy movement of the arms therein and providing ample room for vertical movement of the arms. The forwardly extended ends of the arms 22 are beveled at an approximately forty-five degree angle so that cutter blades 23 mounted thereon will have their cutting edges forwardly and downwardly extended. Suitable springs 24 are provided having one end anchored to the framework 1 and the other end anchored to the upper end of the cutter blade 23. The anchor point on the framework is beneath the anchor point on the cutter blade so that the tension applied by the spring will be directed rearwardly and downwardly. The rearwardly extended ends of the cutter arms 22 abut against and are actuated by the cams 8, 9, 10, 11.

In operation the motor 2 rotates the cam shaft 6 through the pulley 19, pulley 16 and the gears 12, 13. The springs 24 urge the cutter arms 22 rearwardly and the tension on the upper end of the cutter blades tends to soften the cutting action of the blade on the floor surface, and the cutter arm will yield upwardly when an uneven floor is encountered. The operator may tilt the handle 5, placing additional weight on the forward end of the machine, and thus increase the pressure of the cutting blades 23 to effect a closer cut. The rear end of the cutter arms 22 are held in constant contact with the cams on the cam shaft 6, and as the cam shaft 6 rotates, the arms 22 will be moved outwardly and will be moved rearwardly by the springs 24 as the respective cams move past the forwardmost point of their rotation.

The cams 8, 9, 10, 11 are positioned on the cam shaft 6 so that the cutter blades 23 will move forwardly alternately, to facilitate the smooth operation of the machine. The cutter blades 23 are formed of a width to provide a very close fit between the blades, so that a clean path will be cleared from the floor. However, the removal of any blade may be readily accomplished by disconnecting the spring on such blade and withdrawing the blade forwardly through the channel 21. This may be desirable where small paths are desired through the floor covering. The outer edges of the outside blades 23 will be in alignment with the outer margins of the framework 1 so that flooring may be removed along walls and in corners.

While the foregoing is considered a preferred form of the invention, it is by way of illustration only, the broad principle of the invention being defined by the appended claims.

What I claim is:

1. In a floor scraping device, a wheeled framework, a cutter arm housing on said framework, cutter arm channels in said housing, cutter arms loosely mounted in said channels being free to move vertically and longitudinally therein, cutter blades on the forward end of said arms, a rotatable cam shaft mounted on said framework and eccentric cams mounted on said cam shaft, one of said cams being positioned adjacent each of said channels and means for yieldingly maintaining said cutter arms in contact with said eccentric cams and said cutter blades in contact with the floor to be scraped.

2. In a floor scraping device, a wheeled framework, a cutter arm housing on said framework, cutter arm channels in said housing, cutter arms loosely mounted in said channels and being free to move vertically and longitudinally therein, the forward ends of said arms being beveled, cutter blades mounted on the forward end of said arms and extending downwardly and forwardly, a rotatable cam shaft mounted on said framework and eccentric cams mounted on said cam shaft, one of said cams being positioned adjacent each of said channels

3

and means for yieldingly maintaining said cutter arms in contact with said eccentric cams and said cutter blades in contact with the floor to be scraped.

3. In a floor cleaning device, a wheeled framework, a cutter arm housing on said framework, cutter arm channels in said housing, cutter arms loosely mounted in said channels and movable vertically and longitudinally therein, cutter blades on the forward end of said arms, a rotatable cam shaft mounted on said framework and eccentric cams mounted on said cam shaft, one of said cams being positioned adjacent each of said channels, means for yieldingly maintaining said cutter blades in contact with the floor to be scraped and said cutter arms in contact with said eccentric cams and movable forwardly thereby and means on said framework for imparting rotation to said cam shaft.

4. In a floor-covering removing machine, a movable framework, a series of cutter blade arms having cutter blades on the extended ends thereof, mounted on said framework for independent parallel reciprocatory movements relative to the framework and being free to move vertically and longitudinally, means for yieldably maintaining said cutter blades in contact with the floor to be scraped and means in contact with said arms and operable to impart predetermined relative reciprocatory floor-covering stripping movements thereto.

5. In a floor-covering removing machine, a movable framework, a plurality of floating cutter blades mounted on said framework in side by side relation and for reciprocatory cutting movements relative to each other and lengthwise of the framework being free to move longitudinally and vertically, and means carried by the framework and having operable contact with the blades to impart predetermined reciprocatory floor-covering stripping movements thereto and means for urging said blades into contact with said moving means and said cutter blades into yieldable contact with the floor to be scraped.

6. A combination as called for in claim 4 wherein said operating means includes an operating cam for each blade operable to contact said blade and move it in one direction, together with a spring operable to move the blade in the opposite direction to maintain said blade in constant contact with said cam and in yieldable contact with the floor to be scraped.

7. In a floor-covering removing machine, a movable framework, a cutter blade arm mounted on said frame-

4

work for reciprocatory movements forwardly and rearwardly thereof said arm having a cutter blade on one end thereof, and being free to move longitudinally and vertically means for yieldably maintaining said cutter blade in contact with the floor to be scraped and means on the framework maintained in constant friction contact with said arm and operable to impart said movements thereto.

8. In a floor-covering removing machine, a movable framework, channels in said framework a cutter blade mounted in said channels for reciprocatory movements forwardly and rearwardly of said framework, and being free to move vertically and longitudinally in said channels said blade being inclined to the plane of movement of the framework and having its lower edge projecting forward and sharpened for stripping, and means on the framework in contact with the blade and operable to impart said forward movements thereto and means constantly urging said blades rearwardly to maintain a friction contact with said forward moving means and downwardly in yieldable contact with the floor being scraped.

9. In a floor-covering removing machine, a movable framework, a cutter blade arm mounted on said framework and being freely movable longitudinally and vertically for reciprocatory movements in a plane substantially parallel to the plane of movement of the framework and having a cutter blade thereon said blade being inclined downwardly and forwardly and having a lower stripping edge, means carried by the frame and having friction contact with and being operable to impart successive forward strokes to the blade arm and spring means for yieldably urging the blade into contact with the floor being scraped and retracting said arms to maintain constant contact with said forward moving means.

References Cited in the file of this patent

UNITED STATES PATENTS

206,908	Jepson	Dec. 1, 1936
2,236,093	Friend	Mar. 25, 1941
2,245,544	Miller	June 10, 1941
2,279,454	Fischer	Apr. 14, 1942
2,465,192	Booth	Mar. 22, 1949

FOREIGN PATENTS

176,345	Austria	Oct. 10, 1953
413,615	Italy	May 20, 1946