



US 20070158905A1

(19) **United States**

(12) **Patent Application Publication** (10) **Pub. No.: US 2007/0158905 A1**

Fass (43) **Pub. Date: Jul. 12, 2007**

(54) **FUNDRAISING SYSTEM AND METHOD THEREOF**

Publication Classification

(76) Inventor: **Mathew Fass**, Los Angeles, CA (US)

(51) **Int. Cl.**
A63F 3/00 (2006.01)
(52) **U.S. Cl.** **273/243**

Correspondence Address:
PAPARELLA & ASSOCIATES, PLC
930 N. WASHINGTON AVE.
LANSING, MI 48906 (US)

(57) **ABSTRACT**

(21) Appl. No.: **11/417,742**

A fundraising board game for an organization includes a board, the board including a device which supplies an indicia. The indicia corresponds to one or more donation values, wherein the indicia is disposed on a front surface of the board, wherein when the device is activated, the device supplies the indicia corresponding to the one or more donation values, and a user donates the one or more donation values to an organization.

(22) Filed: **May 4, 2006**

Related U.S. Application Data

(63) Continuation-in-part of application No. 11/327,019, filed on Jan. 9, 2006.

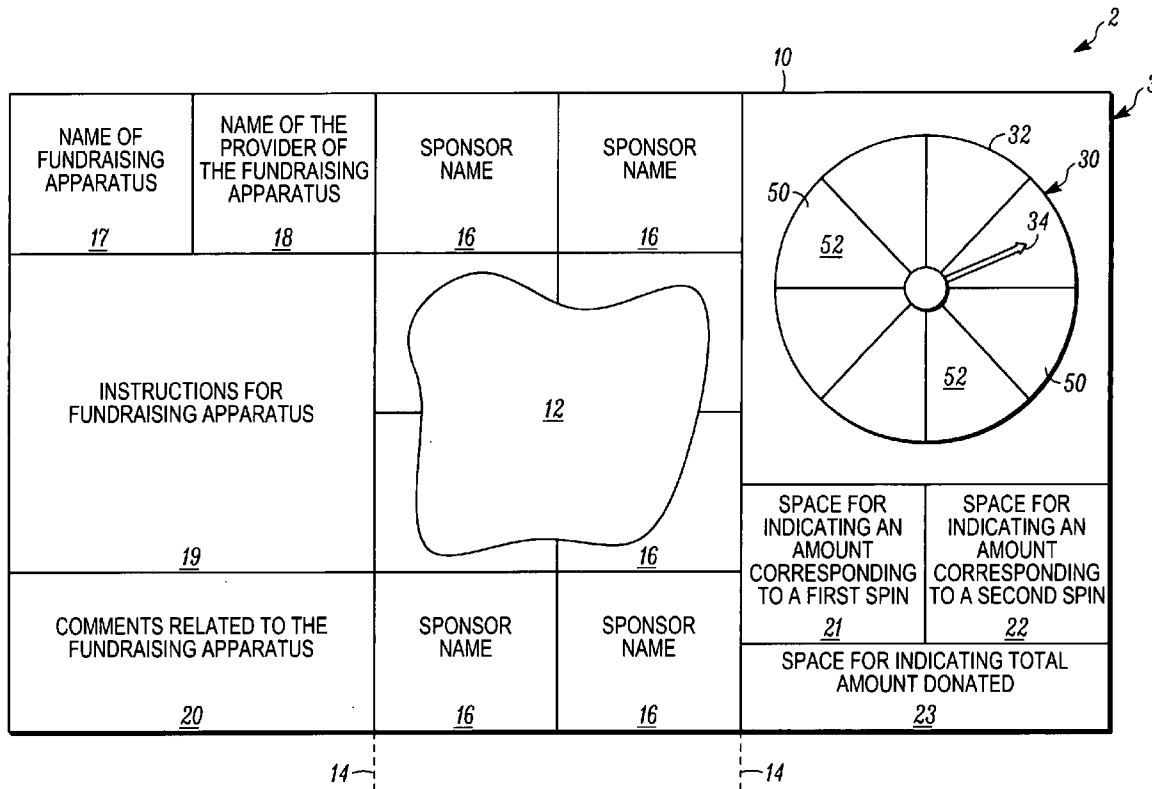

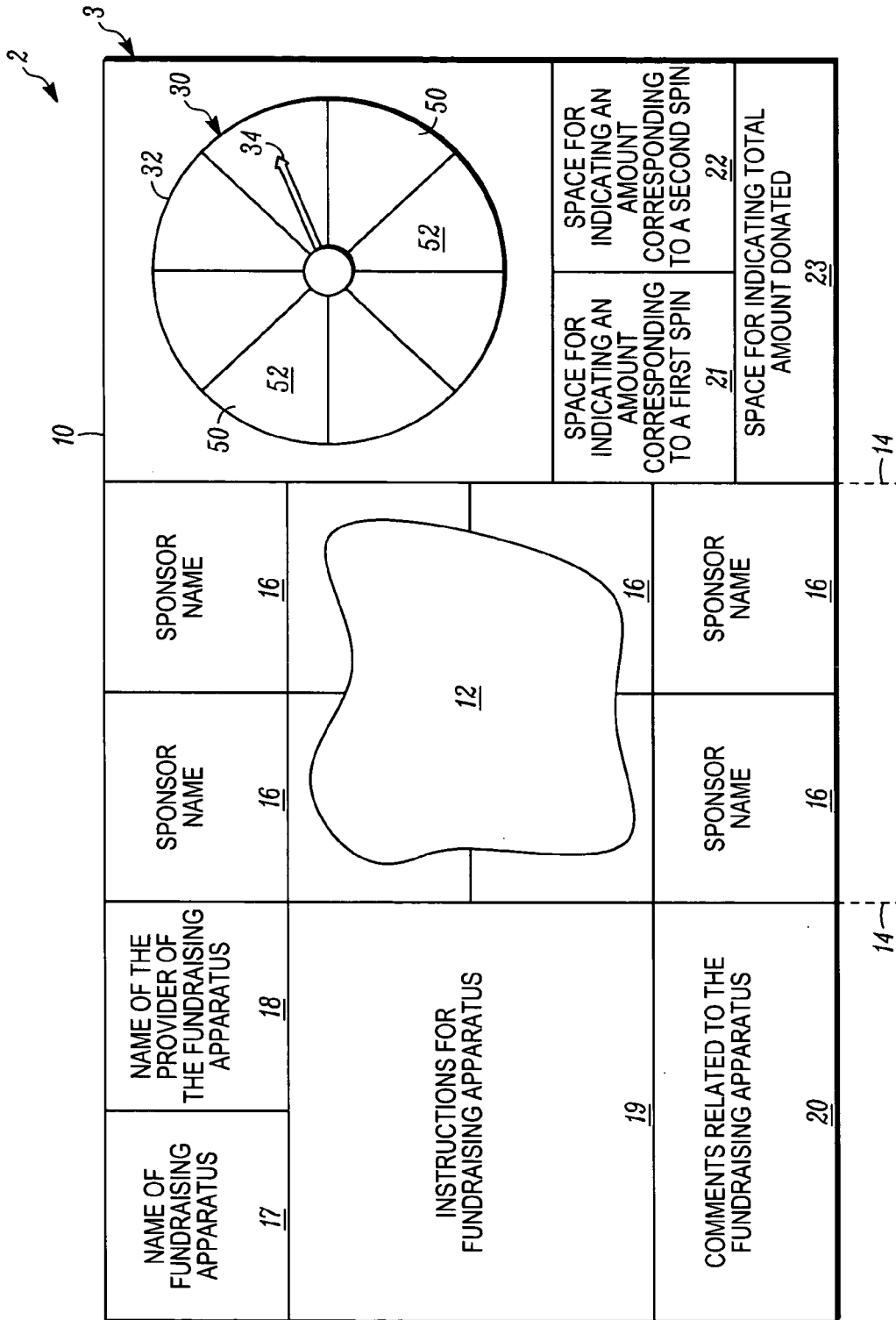

FIG. 1

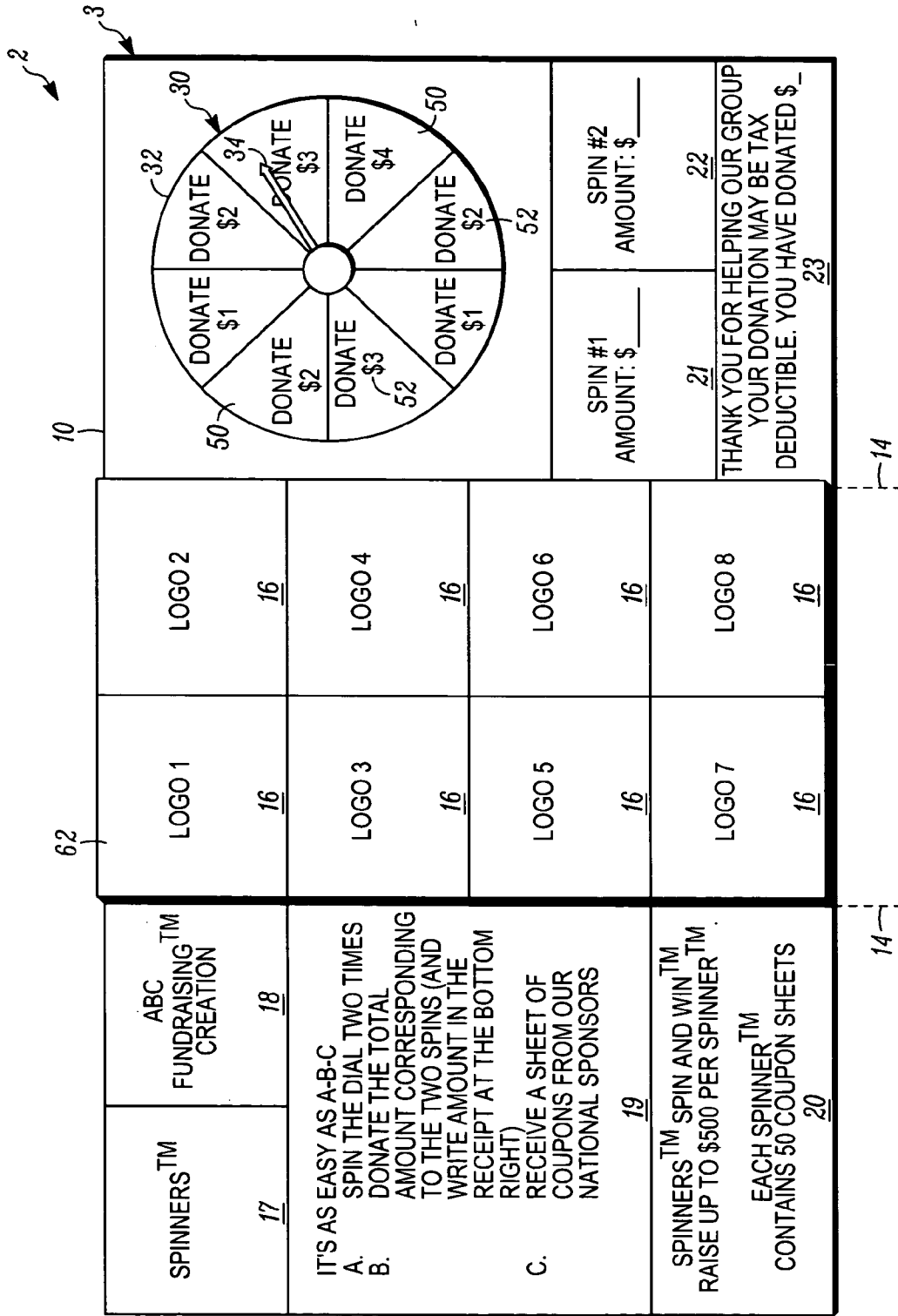

FIG. 2

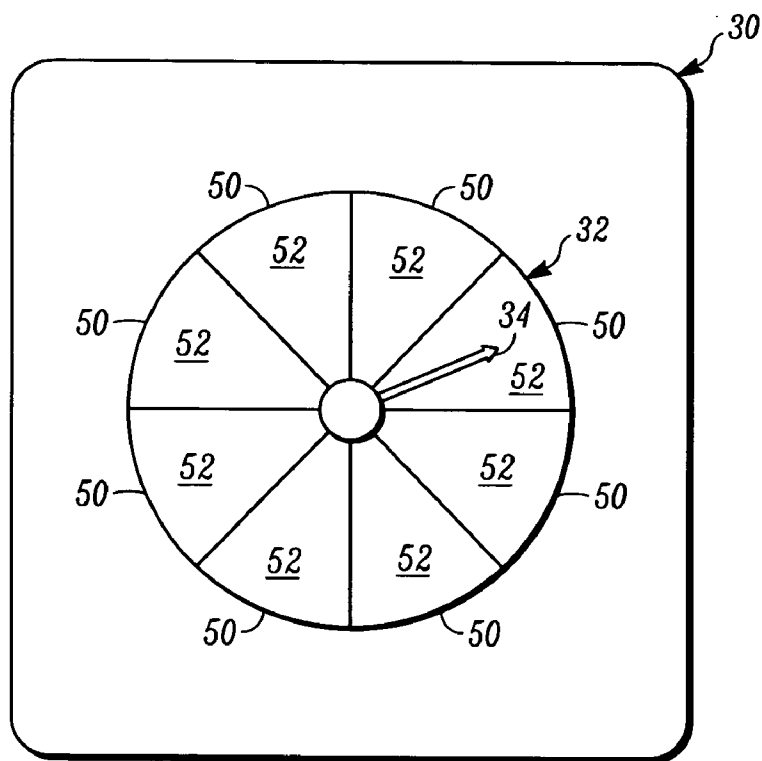

FIG. 3

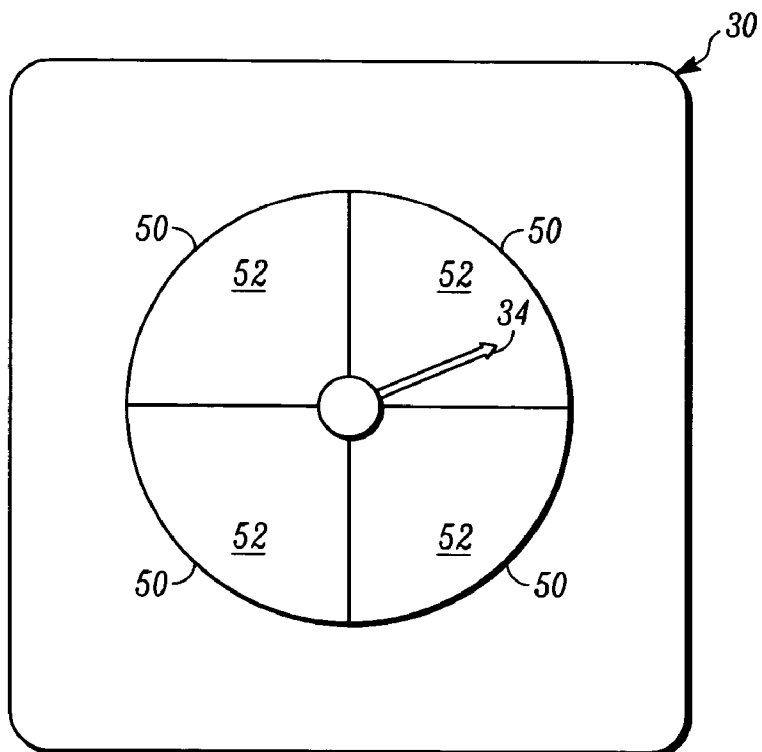

FIG. 4

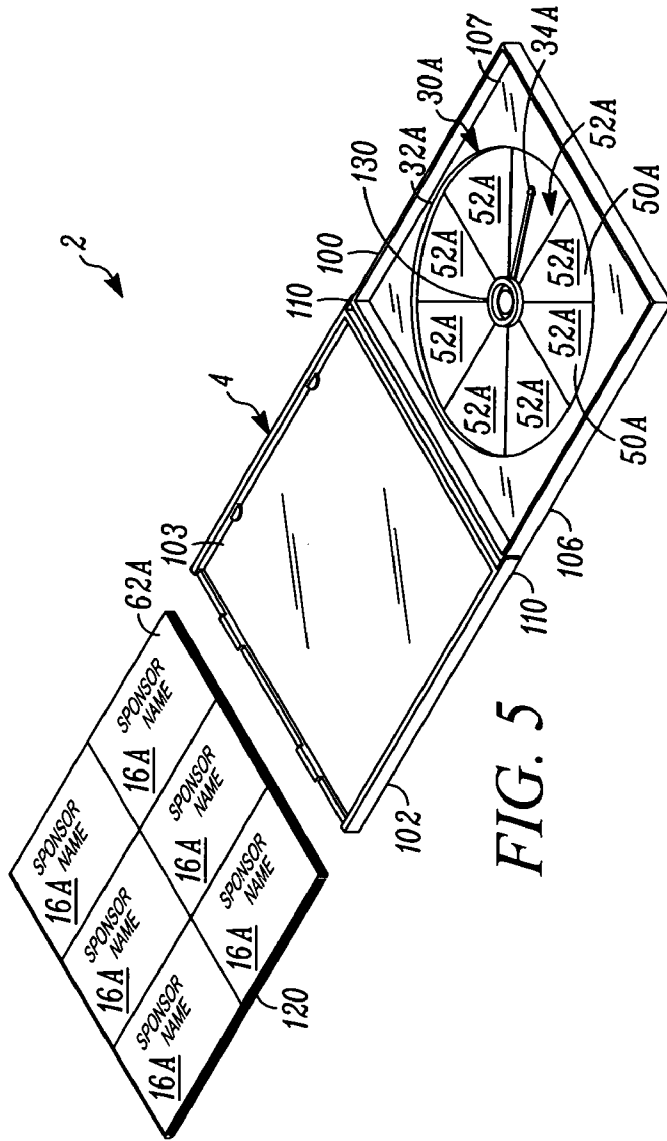

FIG. 5

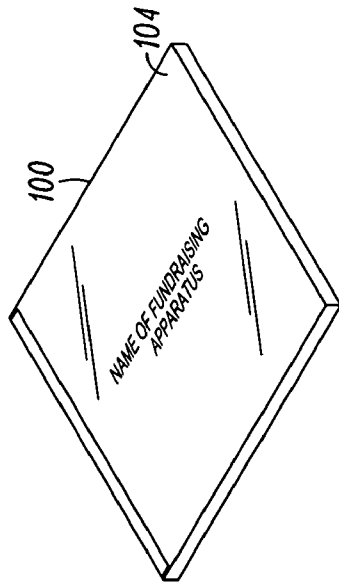

FIG. 6

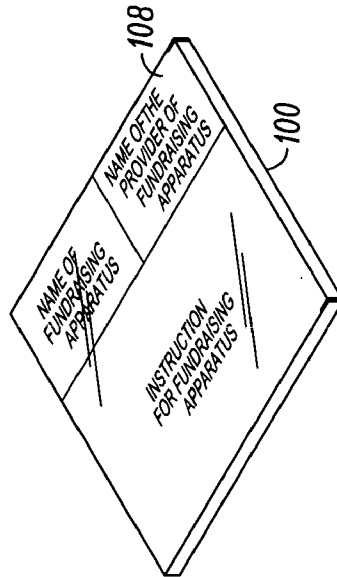

FIG. 7

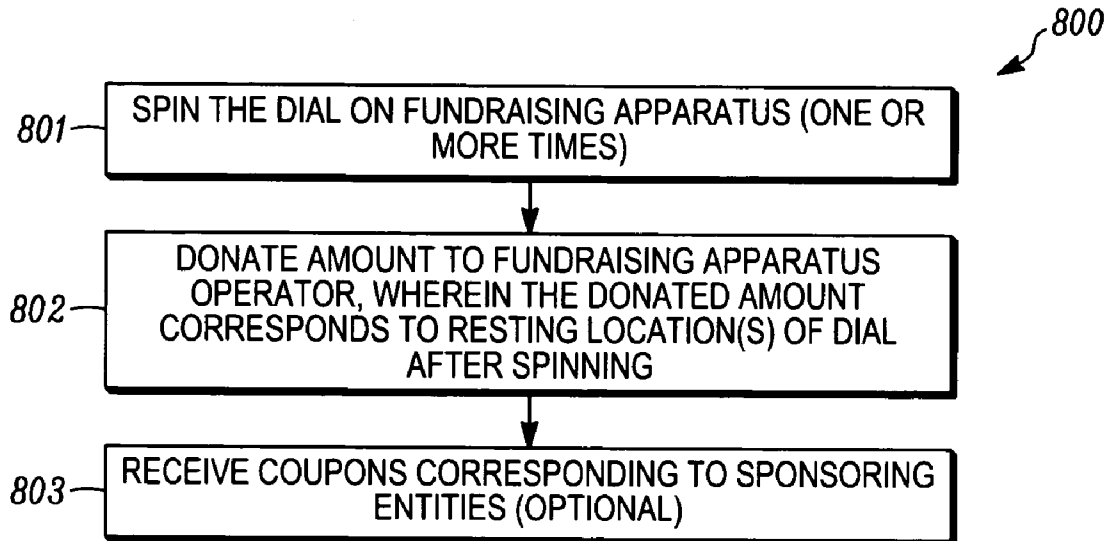

FIG. 8

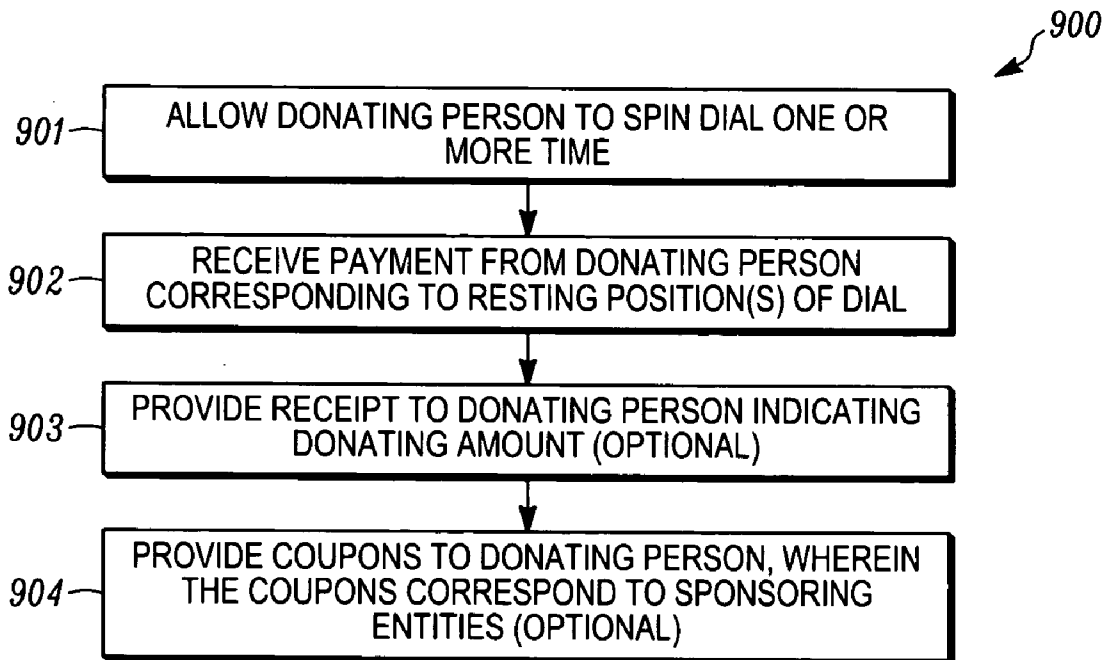

FIG. 9

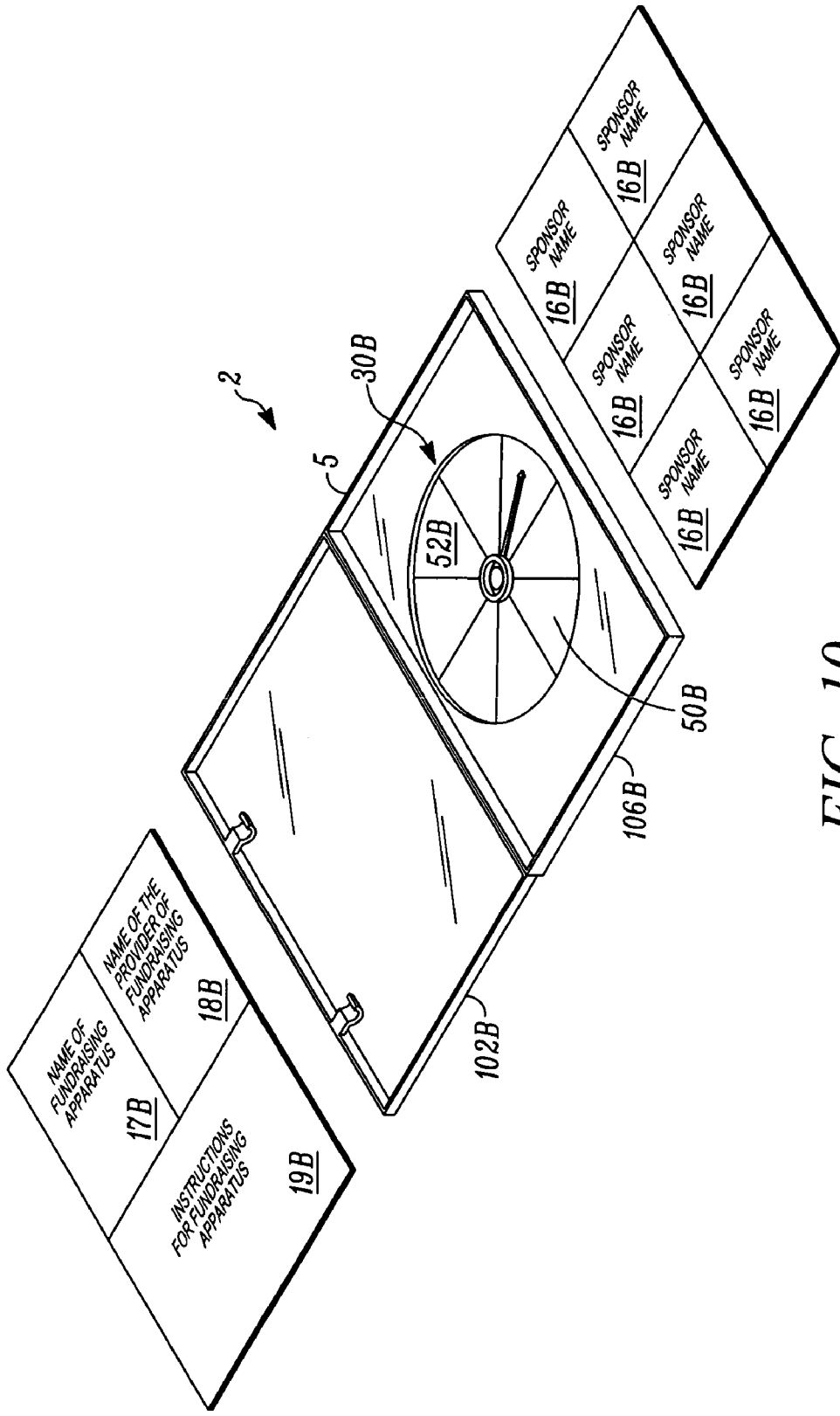

FIG. 10

FUNDRAISING SYSTEM AND METHOD THEREOF

[0001] This application is a continuation-in-part of and claims the benefit of the filing date of U.S. application Ser. No. 11/327,019 entitled "FUNDRAISING SYSTEMS AND METHODS" which was filed on Jan. 9, 2006, and which is incorporated herein by reference.

BACKGROUND OF THE INVENTION

[0002] The present invention pertains to fund-raising generally, and more specifically to systems and methods for soliciting funds.

[0003] Traditionally, funds have been solicited and collected in a variety of ways. These original systems include solicitation through various mediums, and by various methods including, by mail, telephone, radio and television, and of course, one-on-one in-person contact. However, many of the previously developed systems and methods are no longer working, or at least are not working as well. Of course, there are numerous reasons as to why this may be occurring and some of the reasons given have been, because consumers are being more restrictive in their spending, as well as have lower discretionary income. However, another factor is because the average consumer is today being constantly bombarded with information and messages and as such, getting the consumers attention is becoming more difficult. Additionally, more and more consumers are becoming skeptical of the industry as a whole, as well as are becoming increasingly upset with the current tactics of collection. As such, charitable and other fund raising organizations are looking for new and improved systems and methods for soliciting funds from these potential contributors.

[0004] Accordingly, a need exists for novel systems and methods which have, among other advantages, the ability to garner the attention of the consumer, while simultaneously being amusing and entertaining. Therefore, fundraising systems and methods that solve the aforementioned disadvantages and having the aforementioned advantages are desired.

SUMMARY OF THE PRESENT INVENTION

[0005] The aforementioned drawbacks and disadvantages of these former fundraising systems and methods have been identified and a solution is set forth herein by the inventive fundraising system and method which includes a fundraising board game for an organization including a board, wherein the board includes a device which supplies an indicia, wherein further, the indicia corresponds to one or more donation values. The indicia is disposed on a front surface of the board, such that when the device is activated, the device supplies the indicia corresponding to the one or more donation values, and a user donates the one or more donation values to an organization.

[0006] Another aspect of the present invention includes a fundraising system for an organization which includes a case, wherein the case includes a device which supplies an indicia. The indicia corresponds to one or more donation values, and the indicia is disposed on a surface of the case. When the device is activated, the device supplies the indicia corresponding to the one or more donation values, and a user donates the one or more donation values to an organization.

[0007] In another aspect of the present invention, a fund-raising system for an organization is disclosed and includes

an apparatus which comprises a spinnable dial. The spinnable dial is activated by being spun by a user, and after the spinnable dial is spun, the spinnable dial stops spinning to indicate a single donation value, wherein the single donation value corresponds to an amount of money to be donated by the user. The apparatus includes one or more coupons disposed thereon, whereby after the user donates the donation value, the user receives the one or more coupons.

[0008] And still in another aspect of the present invention, a fundraising method for an organization is disclosed which includes: providing a fundraising system comprising a device which supplies an indicia corresponding to one or more donation values, the indicia disposed on a surface of the fundraising system; selecting a user; activating the device, wherein the device supplies the indicia corresponding to the one or more donation values; and receiving the one or more donation values from the user.

[0009] In yet another aspect of the present invention, a method of providing a fundraising system for an organization comprises: providing a fundraising system to a fundraising operator, the fundraising system comprising a device which supplies an indicia corresponding to one or more donation values, wherein the indicia is disposed on a surface of the fundraising system; selecting a user; activating the device, wherein the device supplies the indicia corresponding to the one or more donation values; and receiving the one or more donation values from the user.

[0010] Other objects, advantages, and features of the invention will become apparent upon consideration of the following detailed description, when taken in conjunction with the accompanying drawings. The above brief description sets forth rather broadly the more important features of the present disclosure so that the detailed description that follows may be better understood, and so that the present contributions to the art may be better appreciated. There are, of course, additional features of the disclosures that will be described hereinafter which will form the subject matter of the claims.

[0011] In this respect, before explaining the preferred embodiment of the disclosure in detail, it is to be understood that the disclosure is not limited in its application to the details of the construction and the arrangement set forth in the following description or illustrated in the drawings. The fundraising system of the present disclosure is capable of other embodiments and of being practiced and carried out in various ways. Also, it is to be understood that the phraseology and terminology employed herein are for description and not limitation. Where specific dimensional and material specifications have been included or omitted from the specification or the claims, or both, it is to be understood that the same are not to be incorporated into the claims.

[0012] As such, those skilled in the art will appreciate that the conception, upon which this disclosure is based, may readily be used as a basis for designing other structures, methods, and systems for carrying out the several purposes of the present invention. It is important, therefore, that the claims are regarded as including such equivalent constructions as far as they do not depart from the spirit and scope of the present invention.

[0013] Further, the purpose of the Abstract is to enable the U.S. Patent and Trademark Office and the public generally,

and especially the scientists, engineers, and practitioners in the art who are not familiar with the patent or legal terms of phraseology, to learn quickly from a cursory inspection the nature and essences of the technical disclosure of the application. Accordingly, the Abstract is intended to define neither the invention nor the application, which is only measured by the claims, nor is it intended to be limiting as to the scope of the invention in any way.

[0014] These and other objects, along with the various features, and structures that characterize the invention, are pointed out with particularity in the claims annexed to and forming a part of this disclosure. For a better understanding of the fundraising system of the present disclosure, its advantageous and the specific objects attained by its uses, reference should be made to the accompanying drawings and descriptive matter in which there are illustrated and described the preferred embodiments of the invention.

[0015] While embodiments of the fundraising system are herein illustrated and described, it is to be appreciated that various changes, rearrangements and modifications may be made therein, without departing from the scope of the invention as defined by the claims.

BRIEF DESCRIPTION OF THE DRAWINGS

[0016] FIG. 1 is a front perspective view of an embodiment of the fundraising system of the present invention;

[0017] FIG. 2 is a front perspective view of an embodiment of the fundraising system of FIG. 1;

[0018] FIG. 3 is a front perspective view of an embodiment of a device for supplying an indicia of the fundraising system of FIG. 1;

[0019] FIG. 4 is a front perspective view of another embodiment of a device for supplying an indicia of the fundraising system of FIG. 1;

[0020] FIG. 5 is a front perspective view of another embodiment of the fundraising system of the present invention;

[0021] FIG. 6 is a front perspective view of a front cover of the fundraising system of FIG. 5;

[0022] FIG. 7 is a front perspective view of a rear cover of the fundraising system of FIG. 5;

[0023] FIG. 8 is a flow-chart view of a method of fundraising according to an embodiment of the present invention;

[0024] FIG. 9 is a flow-chart view of yet another method of fundraising according to an embodiment of the present invention;

[0025] FIG. 10 is a front perspective view of yet another embodiment of the fundraising system of the present invention.

DETAILED DESCRIPTION OF THE PREFERRED EMBODIMENT

[0026] The best mode for carrying out the invention is presented in terms of the preferred embodiment, wherein similar referenced characters designate corresponding features throughout the several figures of the drawings.

[0027] For purposes of description herein, the terms “upper”, “lower”, “right”, “left”, “rear”, “front”, “vertical”, “horizontal”, and derivatives thereof, shall relate to the invention as oriented in FIG. 1. However, it is to be understood that the invention may assume various alternative orientations, except where expressly specified to the contrary. It is also to be understood that the specific devices and processes illustrated in the attached drawings and described in the following specification are exemplary embodiments of the inventive concepts defined in the appended claims. Hence, specific dimensions and other physical characteristics relating to the embodiments disclosed herein are not to be considered as limiting, unless the claims expressly state otherwise.

[0028] Reference will now be made in detail to the present preferred embodiments of the invention, examples of which are illustrated in the accompanying drawings. Wherever possible, these same referenced numerals will be used throughout the drawings to refer to the same or like parts. The dimensions illustrated in the drawings (if provided) are included for

[0029] purposes of example only and are not intended to limit the scope of the present invention. Additionally, particular details in the drawings which are illustrated in hidden or dashed lines are to be considered as forming no part of the present invention.

[0030] As used herein, the term board game, is meant to refer to any game played on a premarked surface. Typically, although not required, the game will utilize one or more various dials, counters, pieces, or indicia that are spun, moved or otherwise manipulated in order to provide entertainment. Of course, this is not meant to be limiting in any manner and these board games may take on numerous configurations as is generally known within the art.

[0031] As used herein, the term organization, is meant to refer to one or more individuals or entities having the same or similar shared goals. For example, one or more people, entities, or the like, who represent themselves as belonging to, or being affiliated with a particular group, activity, establishment, or the like. Of course, this is not meant to be limiting in any manner.

[0032] As used herein, the term incentives may be any form of motivation, encouragement or inducement which is designed to increase either the frequency or amount of donation and includes coupons, vouchers, promotional items, and other give-away items regardless of their value. Of course, this is not meant to be limiting in any manner.

[0033] As used herein, the term charitable organization, is meant to refer to any person, group of people, entity, organization or the like which desires to solicit or raise funds including but not limited to organizations as defined by 501(c)(3) of the Internal Revenue Code.

[0034] Traditionally, funds have been solicited and collected in a variety of ways. These original systems include solicitation through various mediums, and by various methods including, by mail, telephone, radio and television, and of course, one-on-one in-person contact. However, many of the previously developed systems and methods are no longer working, or at least are not working as well. Of course, there are numerous reasons as to why this may be occurring, and the reasons given have been, in part, because consumers are

being more restrictive in their spending, as well as have lower discretionary income. Yet another factor is because the average consumer is today being constantly bombarded with information and messages, and as such, getting the consumers attention is becoming more difficult. Additionally, more and more consumers are becoming skeptical of the industry as a whole, as well as are becoming increasingly upset with the current tactics of collection. As such, charitable and other fund raising organizations are looking for new and improved systems and methods for soliciting funds from these potential contributors.

[0035] Accordingly, a need exists for novel systems and methods which have, among other advantages, the ability to garner the attention of the consumer, while simultaneously being amusing and entertaining. Therefore, fundraising systems and methods that solve the aforementioned disadvantages and having the aforementioned advantages are desired.

[0036] The disadvantages and drawbacks of the prior art are overcome through the fundraising systems and methods of the present invention, wherein preferred embodiments of fundraising system 2 are disclosed in FIGS. 1-10. Referring now to FIG. 1, there is shown a fundraising board game 3 for an organization that includes a board 10, wherein board 10 includes a device 30 which supplies an indicia 50. Indicia 50 corresponds to one or more donation values 52 (see generally FIG. 2) and is disposed on a front surface 12 of board 10. When device 30 is activated, indicia 50 is supplied, wherein indicia 50 corresponds to the one or more donation values 52. A user then donates the one or more donation values 52 to the organization.

[0037] In this first embodiment, fundraising system 2 is configured as a fundraising board game 3 and includes board 10 (FIGS. 1 and 2). Board 10 may itself be configured in various embodiments. However, in a first embodiment, board 10 includes a front surface 12, and may be foldable along one or more spines 14. Front surface 12 is the playing surface in this embodiment. Further, spines 14 may be configured so that board 10, when folded, protects front surface 12 by covering it, so as to protect the playing surface. Typically, board 10 is configured to be portable. i.e., transportable and easily carried from one location to another. Board 10 may also include one or more areas 16, disposed on front surface 12, for displaying information on one or more second organizations. For example, the information displayed may include business information, advertisements, logos, and other business related information about the one or more second organizations. These second organizations may be for example, sponsoring organizations that are sponsoring, donating, advertising, or otherwise supporting the first organizations fundraising efforts. Board 10 may also include various other areas or sections disposed on front surface 12 and may include, for example: the name of the fundraising organization, in area 17; the name of the fundraising system provider, in area 18; instructions, in area 19; and comments, in area 20. Additionally, other areas may also be provided that relate to the donation amounts. For example, in one embodiment, areas 21 and 22 and for indicating the donation values 52 corresponding to indicia 50 displayed by device 30, and area 23 may be for a total donation amount that corresponds to the summation of the values in areas 21 and 22. Of course these are merely examples and not meant to be limiting, unless so limited by the claims.

[0038] The specific configuration and various features of board 10 may vary according to specific requirements. In the preferred embodiment, board 10 is generally rectangular in shape and is fabricated in a one-piece configuration from a paper or plastic material. However, the shape of board 10 may vary according to specific requirements, and need not be rectangular in configuration. Further, although one preferred embodiment of board 10 is fabricated from a paper or plastic material, other materials may also be used.

[0039] Device 30 supplies indicia 50, wherein indicia 50 corresponds to one or more donation values 52 (FIGS. 2-4). Device 30 may be a mechanical or electronic device and may display, point out, give, or otherwise indicate indicia 50. In one preferred embodiment, device 30 includes a dial 32 comprising a spinnable indicator 34. In this configuration, spinnable indicator 34 is activated by being spun by the user, wherein after spinnable indicator 34 is spun, spinnable indicator 34 stops spinning on a single donation value 52 (FIG. 2). For example, a donation value corresponding to an amount of money to be donated by the user. In another preferred embodiment, spinnable indicator 34 makes a sound when activated. For example, dial 32 can be made to emit a clicking sound such that when spun, dial 32 sounds like a spinning carnival wheel. Additionally, as illustrated in FIGS. 3 and 4, spinnable indicator 34 may include varied numbers of indicia 50 and donation values 52. Further, it is contemplated that more than one indicator 34 may be provided, either on dial 32, device 30, or on board 10.

[0040] The specific configuration and various features of device 30 may vary according to specific requirements. In the preferred embodiment, device 30 is generally circular in shape and comprises a dial 32 including a spinnable indicator 34. However, the shape of device 30 may vary according to specific requirements, and need not be circular in configuration. Further, although one preferred embodiment of device 30 is mechanical in nature, this is not meant to be limiting, and various electronic devices may also be used.

[0041] Indicia 50 will correspond to one or more donation values 52. For example, donation value 52 corresponds to an amount of money to be donated by the user (FIG. 2). For example, donation value 52 may be a U.S. dollar amount ranging from about \$1 to about \$5. In this manner, device 30, upon activation, supplies indicia 50, corresponding to a particular donation values 52, wherein the user then donates the particular donation value, for example, \$1.00. Of course, other donation values 52 may be utilized, whether of a monetary nature or not. Further, donation values 52 need not be confined to numerical figures.

[0042] Fundraising system 2, and more specifically fundraising board 3, may also include one or more incentives 60, whereby after the user donates the one or more donation values 52, the user receives the one or more incentives 60. Incentives 60 may be any form of motivation, encouragement or inducement which is designed to increase either the frequency or amount of donation. For example, in one embodiment, the incentives include one or more coupons 62. For example, coupons 62 may be releasably attached to front surface 12 of board 10, as illustrated in FIG. 2, whereby after the user donates the one or more donation values 52, the user receives the one or more coupons 62 for use at a later time. In this manner, it becomes apparent that the one or more

second organizations that are sponsoring or otherwise supporting the first organizations fundraising efforts, and which may display or otherwise indicate their sponsorship in the one or more areas 16, may also be the suppliers of the one or more incentives 60. For example, in the preferred embodiment, the same sponsors that appear or are otherwise advertised on area 16 also provide coupons 62. In this manner, as a reward for donating to the first organization, the user is provided with a discount or other valued service by the second organization. The second organization is also rewarded, by the display of the business advertisements and/or gaining prospective clients, in return for their sponsorship. Of course, the providers of the coupons need not be the same as the second organizations sponsoring areas 16.

[0043] While one preferred embodiment has been described, the specific characteristics of fundraising system 2 may be varied to create additional embodiments. One such embodiment includes a fundraising system 4 which includes a case 100 (FIGS. 5-7). Case 100 includes a device 30A which supplies an indicia 50A, the indicia corresponding to one or more donation values 52A, wherein when device 30A is activated, device 30A supplies indicia 50A corresponding to the one or more donation values 52A, as explained previously with respect to fundraising system 3. In one preferred embodiment, fundraising system 4 is similar to fundraising system 3 except that board 10 has been replaced with case 100. As such, for the sake of brevity, case 100 will be described further without references to the similar features that have already been described above.

[0044] As illustrated by FIGS. 5-7, case 100 may include a bi-fold case having left and right case halves 102 and 106, respectively, hingedly connected as at 110. For example, case 100 may be configured similar to a compact disk case (FIG. 5) or a DVD storage case (FIG. 10). In this embodiment, case 100 is opened to reveal device 30A, for example disposed on the inside surface 107 of right half 106. Disposed opposite to device 30A may be a card, booklet, or placard 120. This may be, for example, stored on an inside surface 103 of case half 102 as is known in the art. Placard 120 may include one or more areas 16A for the display of various items, including sponsorship information. Additionally, placard 120 may be configured to be a booklet of removable coupons 62A to provide an incentive 60 for donating as described above. As illustrated, the outside surface or front cover 104 of half 102 may be adorned with various artwork and information, and may include the name of the organization or the name of the fundraising apparatus. Likewise, the outside surface or back cover 108 of half 106 may be adorned with various artwork and information, and may include similar or different information, including directions of use. Additionally, fundraising system 4 may be reused repeatedly, as the case protects device 30A from breakage; and incentives 60A, for example coupon booklet 62A, may be easily replaced when all the coupons have been given away. As such, an economical fundraising system has been developed.

[0045] Although various cases may be utilized, this preferred configuration is such that when case 100 is closed, device 30A, placard 120, and/or coupon booklet 62A are protected and stored therein. Advantageously, the preferred configuration of device 30A, which includes dial 32A and spinnable indicator 34, can be fabricated or retrofitted from an existing CD case (FIG. 5) or DVD case (FIG. 10), or for

example any bi-folding optical disc storage case, as device 30A can be made to fit into the disc storage area, which is the area wherein a normal CD or DVD would fit, and spinnable indicator 34 may be fabricated to work with the existing central holder 130 which is utilized to hold the CD or DVD within the case. In this manner a novel way of retrofitting or using a CD or DVD case to solicit funds has been invented, while reducing the overall costs associated with creating such a game. As described previously FIG. 5 illustrates a fundraising system 4 made from a CD case, and FIG. 10 illustrates a fundraising system 5 made from a DVD case. Like features between the various embodiments utilize similar numerical designations. Where appropriate, the various similar features have been further differentiated by an alphanumeric designation, wherein the corresponding alphabetic designator has been changed.

[0046] The specific configuration and various features of case 100 may vary according to specific requirements. In the preferred embodiment, case 100 is generally rectangular in shape and is fabricated in a bi-folding, hinged configuration from a clear plastic material. However, the shape of case 100 may vary according to specific requirements, and need not be rectangular in configuration. Further, although one preferred embodiment of case 100 is fabricated from a clear plastic, other materials maybe used. Further, yet, other configurations may be used, whether unitary, hinged, or slideably connected.

[0047] In use then, fundraising system 2 includes at least one fundraising apparatus 3, 4 or 5, an apparatus operator, and at least one donating person. Either the operator or the donating person activates device 30, for example by spinning indicator 34, whereupon the donating person waits for spinning indicator 34 to stop spinning on indicia 50, wherein a donation value 52 may be printed, thus signifying, for example, an amount to be donated. This spinning step may be repeated as many times as the game operator or donating person allows, and the subsequent donation amount added, to yield a total amount donated. For example, fundraising system 3, as illustrated by FIG. 1, includes areas 21 and 22 for recording two such spins, wherein area 23 allows the total donation to be recorded.

[0048] FIG. 8 illustrates a flow chart depicting an embodiment of a method 800 which is implemented by a donating person. Herein, the donating person spins a dial 32 (step 801), donates the amount(s) indicated by spinnable indicator 34 to the fundraising apparatus operator (step 802), and receives coupons (step 803) corresponding to the second organization or sponsors of the fundraiser.

[0049] FIG. 9 illustrates a flow chart depicting an embodiment of a method 900 which is implemented by an apparatus operator and includes allowing a donating person to spin a dial one or more times (step 901), receiving a payment from the donating person corresponding to the resting position(s) of dial 32 (step 902), providing a receipt to the donating person indicating the donation amount (optional step 903), and providing coupons 62 to the donating person, wherein coupons 62 correspond to sponsoring entities (optional step 904).

[0050] In yet another embodiment, a fundraising method for an organization includes: providing a fundraising system 2 comprising a device 30 which supplies an indicia 50, the indicia 50 corresponding to one or more donation values 52;

selecting a user; activating device 30, the device 30 supplying indicia 50, after activation, which corresponds to the one or more donation values 52; and receiving the one or more donation values 52 from the user.

[0051] In still yet another embodiment, a method of providing a fundraising system for an organization includes: providing a fundraising system 2 to a fundraising operator, the fundraising system 2 comprising a device 30 which supplies an indicia 50, the indicia 50 corresponding to one or more donation values 52; selecting a user; activating device 30, the device 30 supplying indicia 50 corresponding to the one or more donation values 52; receiving the one or more donation values 52 from the user.

[0052] Advantageously, the fundraising system of the present invention and methods thereof have, among other advantages, the ability to garner the attention of the consumer while simultaneously being amusing and entertaining. Consequently, the embodiments of the preferred invention disclosed herein reveal a fundraising system which is efficiently fabricated, is reusable for maximum profitability, and is more entertaining than existing systems and methods.

[0053] The solutions offered by the invention herein have thus been attained in an economical, practical, and facile manner. To wit, a novel fundraising system which is cost effective, easily installed, strong, and aesthetically pleasing has been invented. While preferred embodiments and example configurations of the inventions have been herein illustrated, shown, and described, it is to be appreciated that various changes, rearrangements, and modifications may be made therein, without departing from the scope of the invention as defined by the claims. It is intended that the specific embodiments and configurations disclosed herein are illustrative of the preferred and best modes for practicing the invention, and should not be interpreted as limitations on the scope of the invention as defined by the claims, and it is to be appreciated that various changes, rearrangements, and modifications may be made therein, without departing from the scope of the invention as defined by the claims.

The invention claimed is:

1. A fundraising board game for an organization comprising:

a board, the board including a device which supplies an indicia;

the indicia corresponding to one or more donation values, the indicia disposed on a front surface of the board;

wherein when the device is activated, the device supplies the indicia corresponding to the one or more donation values, and a user donates the one or more donation values to an organization.

2. The fundraising system of claim 1, wherein:

the fundraising system also includes one or more incentives, whereby after the user donates the one or more donation values, the user receives the one or more incentives.

3. The fundraising system of claim 2, wherein:

the one or more incentives includes one or more coupons disposed on the front surface of the board, whereby after the user donates the one or more donation values, the user receives the one or more coupons.

4. The fundraising system of claim 3, wherein:

the coupons are releasably attached to the front surface of the board.

5. The fundraising system of claim 1, wherein:

the board includes one or more areas, disposed on the front surface of the board, for displaying information on one or more second organizations.

6. The fundraising system of claim 5, wherein:

the fundraising system also includes one or more incentives, whereby after the user donates the one or more donation values, the user receives the one or more incentives;

wherein the one or more second organizations supply the one or more incentives.

7. The fundraising system of claim 1, wherein:

the board is portable and foldable onto itself, thereby protecting the front surface of the board when the board is folded onto itself.

8. The fundraising system of claim 1, wherein:

the device includes a dial comprising a spinnable indicator.

9. The fundraising system of claim 8, wherein:

the spinnable indicator is activated by being spun by the user, and wherein after the spinnable indicator is spun, the spinnable indicator stops spinning on a single donation value, the single donation value corresponding to an amount of money to be donated by the user.

10. The fundraising system of claim 8, wherein:

the spinnable indicator makes sound when activated.

11. The fundraising system of claim 1, wherein:

the one or more donation values corresponds to an amount of money to be donated by the user.

12. The fundraising system of claim 1, wherein:

the organization is a charitable organization.

13. A fundraising system for an organization comprising:

a case, the case including a device which supplies an indicia;

the indicia corresponding to one or more donation values, the indicia disposed on a surface of the case;

wherein when the device is activated, the device supplies the indicia corresponding to the one or more donation values, and a user donates the one or more donation values to an organization.

14. The fundraising system of claim 13, wherein:

the fundraising system also includes one or more incentives, whereby after the user donates the one or more donation values, the user receives the one or more incentives.

15. The fundraising system of claim 14, wherein:

the one or more incentives includes one or more coupons disposed on the case, whereby after the user donates the one or more donation values, the user receives the one or more coupons.

16. The fundraising system of claim 15, wherein:

the case includes two halves pivotably connected, and the coupons are disposed on an inside surface of the case.

17. The fundraising system of claim 13, wherein:
the case includes two halves pivotably connected,
whereby when the case is closed, the device is disposed
therein, and the case is opened to reveal the device.

18. The fundraising system of claim 17, wherein:
the case includes an area for displaying one or more
second organizations information.

19. The fundraising system of claim 17, wherein:
the device includes a dial comprising a spinnable indica-
tor.

20. The fundraising system of claim 19, wherein:
the spinnable indicator is activated by being spun by the
user, and wherein after the spinnable indicator is spun,
the spinnable indicator stops spinning on a single
donation value, the single donation value correspond-
ing to an amount of money to be donated by the user.

21. The fundraising system of claim 20, wherein:
the spinnable indicator makes sound when activated.

22. The fundraising system of claim 13, wherein:
the donation value corresponds to an amount of money to
be donated by the user.

23. A fundraising system for an organization comprising:
a apparatus, the apparatus including a spinnable dial;
wherein the spinnable dial is activated by being spun by
a user, and wherein after the spinnable dial is spun, the

spinnable dial stops spinning to indicate a single dona-
tion value, the single donation value corresponding to
an amount of money to be donated by the user; and
the apparatus includes one or more coupons, whereby
after the user donates the donation value, the user
receives the one or more coupons.

24. The fundraising system of claim 23, wherein:
the apparatus comprises a portable board, the board being
foldable onto itself, thereby protecting a front surface
when the board is folded onto itself.

25. The fundraising system of claim 24, wherein:
the board includes an area, disposed on a front surface, for
displaying one or more sponsoring organizations infor-
mation.

26. The fundraising system of claim 23, wherein:
the apparatus comprises a case including two halves
pivotably connected.

27. The fundraising system of claim 23, wherein:
the spinnable dial is disposed within a bi-folding optical
disc storage case.

28. The fundraising system of claim 26, wherein:
the spinnable dial is disposed within a disc storage area of
the optical disc storage case.

* * * * *