



- (51) International Patent Classification:
B66C 1/12 (2006.01)
- (21) International Application Number:
PCT/US2014/027232
- (22) International Filing Date:
14 March 2014 (14.03.2014)
- (25) Filing Language: English
- (26) Publication Language: English
- (30) Priority Data:
61/789,830 15 March 2013 (15.03.2013) US
- (71) Applicant: **YALE CORDAGE INC.** [US/US]; 77 Industrial Park Road, Saco, Maine 04072 (US).
- (72) Inventors: **YALE, Thomas L.**; 270 Western Avenue, PO Box 317, West Boothbay Harbor, Maine 04575 (US).
HILDEBRAND, Richard W.; 63 Black Point Road, New Gloucester, Maine 04260 (US).
- (74) Agents: **CERNOTA, Andrew P.** et al.; Maine Cernota & Rardin, 547 Amherst St., 3rd Floor, Nashua, New Hampshire 03063 (US).
- (81) Designated States (*unless otherwise indicated, for every kind of national protection available*): AE, AG, AL, AM, AO, AT, AU, AZ, BA, BB, BG, BH, BN, BR, BW, BY, BZ, CA, CH, CL, CN, CO, CR, CU, CZ, DE, DK, DM, DO, DZ, EC, EE, EG, ES, FI, GB, GD, GE, GH, GM, GT, HN, HR, HU, ID, IL, IN, IR, IS, JP, KE, KG, KN, KP, KR, KZ, LA, LC, LK, LR, LS, LT, LU, LY, MA, MD, ME, MG, MK, MN, MW, MX, MY, MZ, NA, NG, NI, NO, NZ, OM, PA, PE, PG, PH, PL, PT, QA, RO, RS, RU, RW, SA, SC, SD, SE, SG, SK, SL, SM, ST, SV, SY, TH, TJ, TM, TN, TR, TT, TZ, UA, UG, US, UZ, VC, VN, ZA, ZM, ZW.
- (84) Designated States (*unless otherwise indicated, for every kind of regional protection available*): ARIPO (BW, GH, GM, KE, LR, LS, MW, MZ, NA, RW, SD, SL, SZ, TZ, UG, ZM, ZW), Eurasian (AM, AZ, BY, KG, KZ, RU, TJ, TM), European (AL, AT, BE, BG, CH, CY, CZ, DE, DK,

[Continued on next page]

(54) Title: MULTI PART SYNTHETIC EYE AND EYE SLING

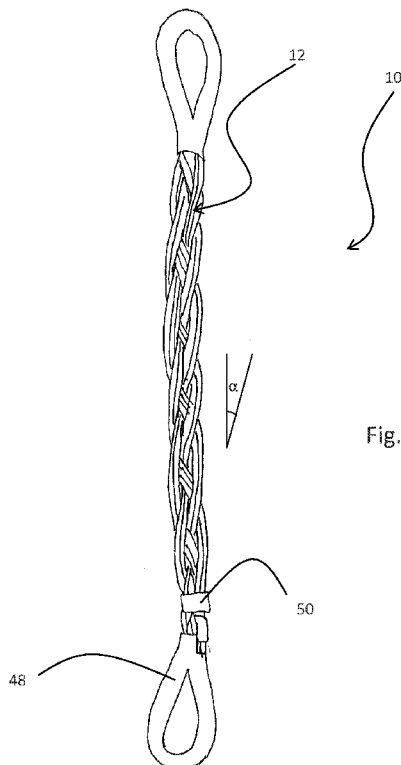

Fig. 1

(57) Abstract: A system for applying a tensile load, the system having: a length of continuous synthetic rope having first and second bitter ends; the continuous synthetic rope being woven with itself to create a sling; the first and second bitter ends of the rope being capable of moving relative to each other and the sling. The system may be configured such that movement of the bitter ends relative to the sling or each other is observable or measurable. Systems may be slings that provide a plurality of wraps of a continuous synthetic rope having loops at opposing ends; the plurality of wraps of continuous synthetic rope having at least three parts and being woven such that the resulting woven sling has at least three picks.

EE, ES, FI, FR, GB, GR, HR, HU, IE, IS, IT, LT, LU,
LV, MC, MK, MT, NL, NO, PL, PT, RO, RS, SE, SI, SK,
SM, TR), OAPI (BF, BJ, CF, CG, CI, CM, GA, GN, GQ,
GW, KM, ML, MR, NE, SN, TD, TG).

— *of inventorship (Rule 4.17(iv))*

Published:

— *with international search report (Art. 21(3))*

— *before the expiration of the time limit for amending the claims and to be republished in the event of receipt of amendments (Rule 48.2(h))*

Declarations under Rule 4.17:

— *as to applicant's entitlement to apply for and be granted a patent (Rule 4.17(ii))*

— *as to the applicant's entitlement to claim the priority of the earlier application (Rule 4.17(iii))*

MULTI PART SYNTHETIC EYE AND EYE SLING

RELATED APPLICATIONS

[0001] This application claims the benefit of U.S. Provisional Application No. 61/789830, filed March 15, 2013. This application is herein incorporated by reference in its entirety for all purposes.

FIELD OF THE INVENTION

[0002] The invention relates to slings, and more particularly, to a synthetic rope multi-cable woven sling.

BACKGROUND OF THE INVENTION

[0003] Eye and eye lifting slings exist in various forms made of metals and synthetics in single element form and in multi part or element form. In metal or wire rope a sling may be formed by utilizing a single length of wire and forming an eye in each end by splicing, swaging, or potting. In synthetic form a sling may be formed similarly by utilizing a single length of rope (of any construction such as 3 strand, single braid, double braid, parallel, plaited, etc.) and forming an eye in each end by splicing, swaging, knotting, potting, etc. Flat synthetic webbing is also widely used to make slings by folding an eye in each end and stitching the bitter end to the standing part of the webbing, thus forming eyes that can be attached between an object to be lifted and to an apparatus designed to exert a lifting force. Synthetic slings are also formed by utilizing a strength element such as a twisted strand of fibers (or braided element) and laying a continuous length in a circular path making multiple laps until a

desired combined strength is achieved and then enclosing these strands within a "sock" of suitable cloth type material.

[0004] Each of these various types of slings has advantages and disadvantages. The biggest difference between wire based slings versus synthetic slings is weight. For a given lift capacity, the synthetic alternative is 4 to 10 times lighter. Wires' principle advantages are high abrasion resistance, high UV resistance, high temperature tolerance, and cheaper initial cost. Its disadvantages are high weight, stiffness, low corrosion resistance, abrasive to other objects, high conductivity, loss of strength in smaller bend diameters, difficulty of inspection (because of weight) and high recoil and spring-back. Synthetic slings (of high strength fibers such as aramids, ultra high molecular weight polyethylene, liquid crystal polymers, etc.) are much lighter to handle, non-corrosive, non-abrasive to other objects, very flexible, easy to store and have better strength retention over small diameter pins and lift hooks, and have low to no conductivity.

[0005] The disadvantages of current synthetic slings are higher cost, lower tolerance to high temperatures, difficult to inspect (sleeve enclosed strength fibers), cannot be pushed (as in under objects), lower tolerance to UV degradation, prone to contamination and moisture penetrating to the strength elements, easily cut and bulky. When wire slings are fabricated for higher lifting capacity, a typical method is to use multiple strands or "parts" of a given size of wire. This is primarily done because of the difficulty of bending a larger single wire rope into a manageable eye size and the associated loss of strength when bent too sharply. Typically, the wire is fabricated into a 3 part (or pass) configuration. Then two or three "matched" sets of the 3 part slings are combined to form a 6 or 9 part sling. The current invention is an improvement over this type of multipart sling utilizing synthetic strength elements configured or fabricated in a more efficient product, such that the advantages of wire style and synthetic style slings are embodied while eliminating or minimizing the disadvantages.

[0006] What is needed, therefore, are techniques for manufacturing synthetic slings of lower cost and higher performance.

SUMMARY OF THE INVENTION

[0007] One embodiment of the present invention provides a system for applying a tensile load, the system comprising: a length of continuous synthetic rope having first and second bitter ends; the continuous synthetic rope being woven with itself to create a sling; the first and second bitter ends of the rope being capable of moving relative to each other and the sling.

[0008] Another embodiment of the present invention provides such a system further comprising markings disposed on the first and the second bitter ends showing movement of the first and second bitter ends relative to each other.

[0009] A further embodiment of the present invention provides such a system further comprising measurement indicia disposed along the continuous synthetic rope showing elongation of the rope.

[0010] One embodiment of the present invention provides a system for applying a tensile load, the system comprising:

[0011] a plurality of wraps of a continuous synthetic rope having loops at opposing ends;

[0012] the plurality of wraps of the continuous synthetic rope having at least three parts and being woven such that the resulting woven sling has at least three picks.

[0013] Another embodiment of the present invention provides such a system wherein each wrap within the plurality of wraps is configured to move relative to other wraps within the plurality of wraps.

[0014] A further embodiment of the present invention provides such a system wherein individual wraps are configured to shift relative to each

other and to conform to a holder and seek an optimal load bearing configuration of the wraps when the sling is placed under load.

[0015] Still another embodiment of the present invention provides such a system wherein the wraps in the plurality move relative to each other to be substantially equally loaded when a load is applied to the sling.

[0016] A still further embodiment of the present invention provides such a system wherein the load approaches a design load of the sling.

[0017] Yet another embodiment of the present invention provides such a system wherein the wraps are configured to decrease movement relative to each other when a load approaching a design load of the sling is applied.

[0018] A yet further embodiment of the present invention provides such a system wherein the inside radius of each wrap forming a portion of the loops is independently assumed in load distribution balance with its neighboring wraps when the sling is placed under load.

[0019] Even another embodiment of the present invention provides such a system wherein the sling is torsionally neutral.

[0020] An even further embodiment of the present invention provides such a system wherein the sling is non-conductive when dry.

[0021] Still yet another embodiment of the present invention provides such a system wherein the sling has a mechanical resonance less than 0.1 that of a steel sling of comparable design load.

[0022] A still yet further embodiment of the present invention provides such a system wherein the wraps are substantially free of sharp edges.

[0023] Even yet another embodiment of the present invention provides such a system wherein the rope comprises a primary strength member and a jacket disposed over the primary strength member.

[0024] An even yet further embodiment of the present invention provides such a system wherein the ratio of the bending strength of the sling divided by its column strength is less than 10% of a steel sling.

[0025] An even still further embodiment of the present invention provides such a system wherein the sling has a pushability such that the sling without external support will vertically support a length of itself not less than about 5 times the circumference of the sling.

[0026] Another yet further embodiment of the present invention provides such a system further providing visual indicia disposed on bitter ends of the rope, such that movement of the bitter ends relative to each other is observable and measurable.

[0027] One embodiment of the present invention provides a pushable woven synthetic sling retaining a high translation, the sling comprising: a synthetic rope disposed in a plurality of wraps; the plurality of wraps being woven in a weave having a weave angle α , the wraps shifting relative to each other such that a load on the sling is distributed evenly among the wraps but the wraps do not unweave, the shifting ability of the wraps being diminished in approximate proportion with the increase of the weave angle α and load applied to the sling.

[0028] The features and advantages described herein are not all-inclusive and, in particular, many additional features and advantages will be apparent to one of ordinary skill in the art in view of the drawings, specification, and claims. Moreover, it should be noted that the language used in the specification has been principally selected for readability and instructional purposes, and not to limit the scope of the inventive subject matter.

BRIEF DESCRIPTION OF THE DRAWINGS

[0029] Figure 1 is a plan view illustrating a synthetic cable sling configured in accordance with one embodiment of the present invention.

[0030] Figure 2 is a diagram illustrating a wrapping of a synthetic cable sling configured in accordance with one embodiment of the present invention.

[0031] Figure 3 is a perspective view illustrating braiding of a synthetic cable sling configured in accordance with one embodiment of the present invention.

[0032] Figure 4 is a perspective view illustrating wrapping an eye of a synthetic cable sling configured in accordance with one embodiment of the present invention with anti-chafing protective material.

[0033] Figure 5 is a perspective view illustrating termination of a synthetic cable sling configured in accordance with one embodiment of the present invention.

[0034] Figure 6 is a perspective view illustrating securing ends of a synthetic cable sling configured in accordance with one embodiment of the present invention having markings or indicia of movement.

[0035] Figure 7 is a flow chart illustrating a method for manufacturing synthetic cable sling configured in accordance with one embodiment of the present invention.

DETAILED DESCRIPTION

[0036] One embodiment of the present invention, illustrated in **Figure 1** provides a sling **10** of braided synthetic rope or cable **12**. Such a sling **10** would have a lighter weight than steel wire or known synthetic round sling of equal lift capacity, with less bulk than the known synthetics. Such a sling **10** would be configured to exhibit very high resistance to UV degradation. One embodiment of the present invention uses higher fiber efficiency than known synthetic sling systems and higher strength retention over small diameters than wire. While this invention has been discussed in regards to lifting, one skilled in the art will appreciate that eye and eye slings are used in a variety of applications, including but not limited to lifting, restraining, stabilizing, pulling, and suspending loads.

[0037] A sling 10 configured in accord with one embodiment of the present invention provides a plurality of wraps of a synthetic rope which are woven together, creating a plurality of picks. A pick count is defined in the industry under International Standard CI1202 as adopted by American Standards for Testing and Materials (ASTM International) as “In a braided rope, the number of strands rotating in one direction in one cycle length divided by the cycle length. Each multiple Strand with multiple yarns should be counted as one strand. Pick count is normally expressed in picks per inch.” *See* International Standard CI1202-03, p.5.

[0038] In one embodiment there are not fewer than three picks. Each pick may be made using a number of parts (i.e. rope segments), at least three such parts are necessary, and while possible, parts in excess of 15 may be of diminished practical value and increase production cost. The angle α of each part within a pick relative to the longitudinal axis of the sling as a whole affects the ability of wraps within the sling to reach equilibrium in load sharing by their relative movement. The design of a sling must, therefore, consider and balance the benefits of increased translation efficiency from lower angles against the consequent diminution

of elongation and energy absorption which could be obtained at higher angles.

[0039] Five functional performance parameters are directly and predictably affected by the change in the weave angle of the invention according to the relationship “Cosine α ”;

- Pushability
- Translation
- Elongation
- Adjustment Potential among the individual wraps
- The Force of Constriction

[0040] Pushability is the ability of one embodiment of the present invention, when vertically disposed, to sustain its own weight without collapse. Pushability increases with an increasing weave angle, offset by an increasing unit weight.

[0041] Translation is the percent of theoretical tensile load achievable divided into the actual tensile load capacity. This percentage diminishes as the angle increases.

[0042] Elongation is the extension potential within the rope itself, i.e. how much the rope can stretch, plus the mechanical extension potential within the woven sling. Both of these potentials increase with the braid angle, but reach their respective limits, of about 3.5% and 4% respectively, before the angle increases much beyond 30 degrees or so. The actual limits and corresponding angles depend upon fiber, rope construction, coatings, and other factors.

[0043] Adjustment potential of the individual wraps with respect to each other also increases but is impeded by increases in friction, among wraps in mutual contact, with an increasing weave angle. Friction is the direct result of the frictional coefficient of the rope surface multiplied by

the “Normal” Force. The Normal Force is the reactionary force to the Force of Constriction created by an applied load to the sling.

[0044] The Force of Constriction rises with an increasing weave angle and is a characteristic of virtually anything stretched and therefore subjected to “Stretcher Reduction”. That is, something with a uniform starting state and which is uniformly stretched will reduce in diameter or girth in direct proportion to its extension. Because the invention is a “composite” device and therefore not entirely uniform, stretcher reduction and its inherent forces are not easily predicted, analytically. Nevertheless, the Force of Constriction and therefore the Normal Force causing friction has a significant impact on wrap adjustment potential.

[0045] Thus, the various embodiments of the present invention utilize the properties listed above to optimize the utility, safety, convenience, and therefore value to the user, and very favorably so in contrast to other competing products.

[0046] A sling **10** configured according to the embodiments of the present invention allows for easier and more thorough inspection. It is configured with sufficient rigidity to be "pushed", under objects and through gaps unlike known synthetic systems which are too limp, while being more flexible and with lower energy recoil than that steel slings. As one of ordinary skill in the art would appreciate, this allows storage in smaller spaces.

[0047] Such a sling **10** would exhibit higher abrasion and cut resistance and higher temperature resistance than known synthetics and be less abrasive and more corrosion resistant than steel systems. In one embodiment, strength elements are sealed from moisture and contaminants.

[0048] One embodiment of the present invention would provide lower point loading than wire slings through broader load spreading. The system would provide low to no conductivity.

[0049] As illustrated in **Figure 1**, one embodiment of the present invention is a sling **10** constructed from a synthetic rope or cable **12** such as UNITREX™ (manufactured by Yale Cordage) synthetic cable. Various embodiments of the invention can utilize an appropriate variety of fiber as the strength member or jacketing material. As an example, the primary load bearing fiber could be an aramid (Kevlar®, Technora®, Twaron®), ultra high molecular weight polyethylene (UHMWPE) (Spectra®, Dyneema®), liquid crystal polymer (Vectran®), PBO (Zylon®), glass, carbon, etc.

[0050] The sling **10** configured in accordance with one embodiment of the present invention is woven into an eye and eye sling by the following method(s):

[0051] As illustrated in **Fig. 2** suitable length of rope **12** is wound in laps **16** around two opposing pins **14**, **18** of appropriate diameter (typically 4 to 12 times the rope diameter) such that 2 laps are needed for a 2 part sling, 3 laps for a 4 part, 4 laps for a 6 part, 5 laps for an 8 part, 6 laps for a 10 part, and so on. In one embodiment that is illustrated in **Figure 2**, a stage in construction of an 8 part sling **10** is shown: A flow chart of the construction is illustrated in **Figure 8**. Five laps **16** are wound around the pins **14**, **18**. One skilled in the art will appreciate that the numbers of wraps **16** are based on the desired number of parts to the sling.

[0052] The eyes on the two pins are taped (or seized) **28** forming four distinct eyes **40** on each end. A first end **42** is temporarily taped to a first lap **30** (top eye) and a second end **44** to a last lap (bottom eye) **36**. Following the groups formed at pin **18** back to pin **14** and tape **28** the groups together at pin **14**. The first group **30** will have 3 elements of rope the middle groups **32** will have 2 elements rope and the last group **36** will have 3 elements rope. The eyes **40** are lifted off of pin **18** and are braided with, in one embodiment, a 4 end braid with the lay length of 26 to 40 times the diameter of the rope **12** (or other element), as illustrated in **Fig. 3**. One skilled art will appreciate that a number of lay lengths is required to ensure that the braid is properly bound to prevent release of the cables

from the braid. It has been found that the number of lay lengths required is not fewer than 3. While the term "braid" has been used to describe the sling, the ropes may be combined through any appropriate combination, including but not limited to weaving, splicing, braiding, tating, or darning to allow for multiple rope lengths interlocking and forming a sling. The throat **46** of bundled eyes **40** at each end are then seized and may be wrapped with an appropriate chafe protection material **48** (**Fig. 4**). As illustrated in **Figure 5**, ends **42** and **44** are then untaped and exposed (short of the start of the eyes at pin **18**) and then paired parallel and trimmed so they are the same length. As illustrated in **Fig. 6** heavy wall "cold shrink" tube **50**, of a length at least 4 times the diameter of the rope **12** is then passed over the two ends **42**, **44** and secured in place by removing the internal coil.

[0053] One skilled in the art will appreciate that the outer cover material could be anyone of these materials to suit a particular purpose such as high heat resistance that would dictate glass, carbon, or Kevlar® fiber.

[0054] The outer material could also be an extrusion to minimize conductivity under wet conditions.

[0055] The two ends **42**, **44** that are held by the cold shrink tubing serve as indicators that the sling elements are not becoming unbalanced. If overloading takes place or if the elements become unbalanced, the 2 ends **42**, **44** will become uneven in length or move relative to surrounding assembly. Similarly, indicia or markings **90** may be made on the whole rope or some part thereof to indicate changes in alignment of the ends relative to themselves or the sling or elongation or distention of some part of the rope in the sling.

[0056] In one embodiment of the present invention, the ends **42**, **44** of the rope are left un-spliced. While it was expected that splicing of the ends would be required to achieve an efficiency of 70%, this was found not to be the case. Not only was it unnecessary to splice them but it was discovered

that the method yields a translation of between 70% to 90%. The method in fact accommodates element equalization to achieve this high conversion. It also has the advantage of providing for an imbalance indicator as well as being less time consuming to fabricate.

[0057] The method as illustrated in the flow chart of **Figure 7** includes: Select two cylinders, typically having a diameter between 4-12 times the diameter of the chosen synthetic fiber **60**. Then the two cylinders are fixed to a flat surface **62**. The number of parts, or stressed lengths of synthetic fiber needed are determined **64** as are the number of “laps,” or complete paths between the two cylinders, that must be completed **66**. Fiber is wrapped around the cylinders **68** and cut **70** approximately where it lines up with the cable starting point, end **42**, forming end **44**. The loops of fibers are separated and fixed **72** on cylinders **14** and **18**, creating distinct loops and bundled or fixed into laps proximate to each cylinder **74**. Loops thus formed are lifted from cylinder **18**, and braided **76**. Loops are aligned and bundled to form eyelets and secured in appropriate anti-chafe material **78**. The ends, **42**, **44** are removed from their tape and trimmed so that the ends are flush or parallel with each other **80**. The ends are then fixed securely to each other **82** by applying a self-amalgamating tape or a cold shrink tube to the ends or another attachment system that allows for secure retention of the ends while allowing the ends to move relative to each other.

The foregoing description of the embodiments of the invention has been presented for the purposes of illustration and description. It is not intended to be exhaustive or to limit the invention to the precise form disclosed. Many modifications and variations are possible in light of this disclosure. It is intended that the scope of the invention be limited not by this detailed description, but rather by the claims appended hereto.

CLAIMS

What is claimed is:

- 1 1. A system for applying a tensile load, the system comprising:
2 a length of continuous synthetic rope having first and second bitter
3 ends;
4 said continuous synthetic rope being woven with itself to create a
5 sling;
6 said first and second bitter ends of said rope being capable of
7 moving relative to each other and said sling.
1 2. The system of claim 1 further comprising markings disposed
2 on said first and said second bitter ends showing movement of
3 said first and second bitter ends relative to each other.
1 3. The system of claim 1 further comprising markings disposed
2 on said continuous synthetic rope showing movement of said
3 first and second bitter ends relative to said sling.
1 4. The system of claim 1 further comprising measurement indicia
2 disposed along said continuous synthetic rope showing
3 elongation of said rope.
1 5. A system for applying a tensile load, the system comprising:
2 a plurality of wraps of a continuous synthetic rope having loops at
3 opposing ends;
4 said plurality of wraps of said continuous synthetic rope having at
5 least three parts and being woven such that the resulting woven
6 sling has at least three picks.
1 6. The system of claim 5 wherein said woven sling is configured
2 such that each wrap in said plurality of wraps moves relative
3 to other wraps within said plurality of wraps.

- 1 7. The system of claim 6 wherein wraps are configured to shift
2 relative to each other and to conform to a holder and seek an
3 optimal load bearing configuration of the wraps when the sling
4 is placed under load.
- 1 8. The system of claim 6 wherein said wraps in said plurality
2 move relative to each other to be substantially equally loaded
3 when a load is applied to said sling.
- 1 9. The system of claim 7 wherein said load approaches a design
2 load of said sling.
- 1 10. The system of claim 6 wherein said wraps are configured to
2 decrease movement relative to each other when a load
3 approaching a design load of said sling is applied.
- 1 11. The system of claim 5 wherein the inside radius of each wrap
2 forming a portion of said loops is independently assumed in
3 load distribution balance with its neighboring wraps when the
4 sling is placed under load.
- 1 12. The system of claim 5 wherein said sling is torsionally neutral.
- 1 13. The system of claim 5 wherein said sling is non-conductive
2 when dry.
- 1 14. The system of claim 5 wherein said sling has a mechanical
2 resonance less than 0.1 that of a steel sling of comparable
3 design load.
- 1 15. The system of claim 5 wherein said wraps are substantially free
2 of sharp edges.

- 1 16. The system of claim 5 wherein said rope comprises a primary
2 strength member and a jacket disposed over said primary
3 strength member.
- 1 17. The system of claim 5 wherein the ratio of the bending strength
2 of the sling divided by its column strength is less than 10% of
3 a steel sling.
- 1 18. The system of claim 5 wherein said sling has a pushability such
2 that said sling will vertically support a length of itself not less
3 than 5 times the circumference of said sling.
- 1 19. The system of claim 5 further providing visual indicia
2 disposed on bitter ends of said rope, such that movement of
3 bitter ends of said continuous synthetic rope relative to each
4 other is observable.
- 1 20. The system of claim 5 further providing visual indicia
2 disposed on said continuous synthetic rope, such that
3 movement of bitter ends of said continuous synthetic rope
4 relative to said woven sling is observable.

1/5

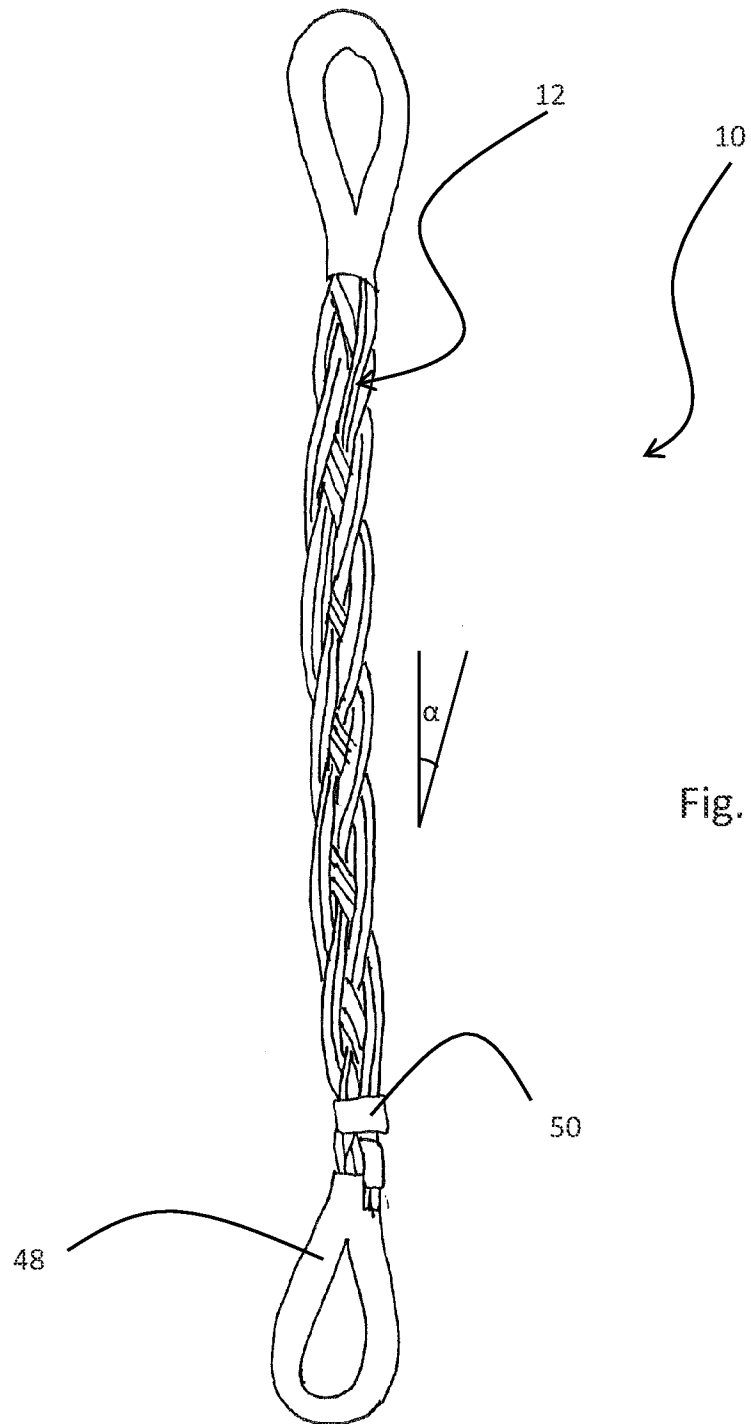

Fig. 1

2/5

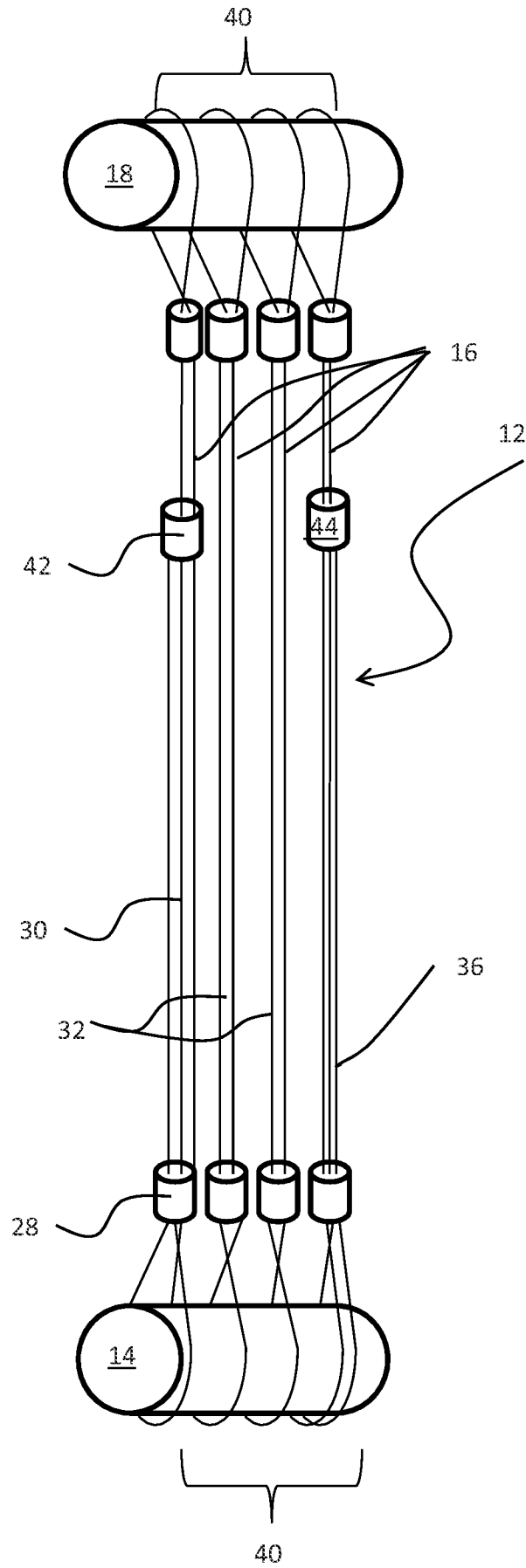

Fig. 2

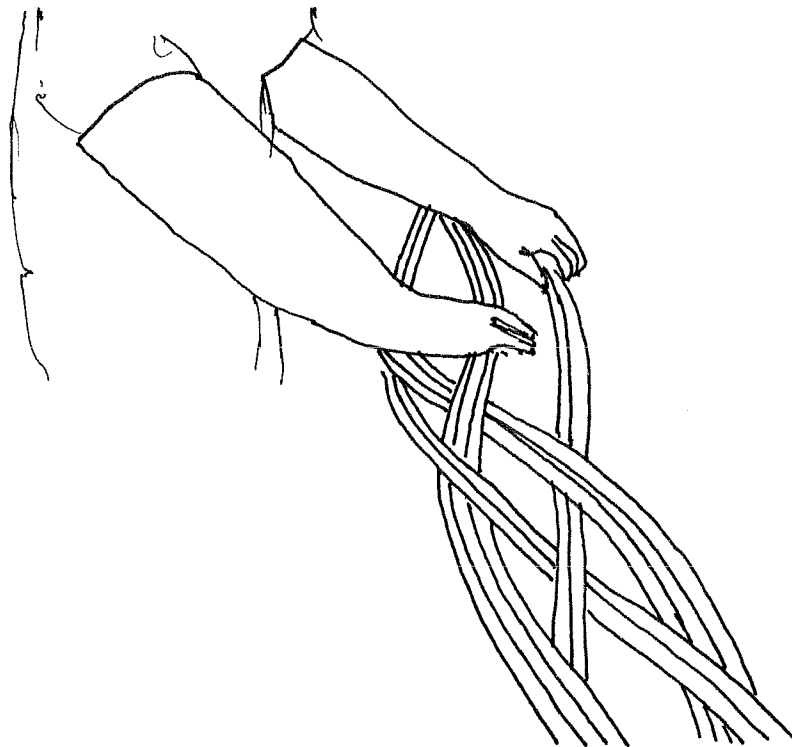

Fig. 3

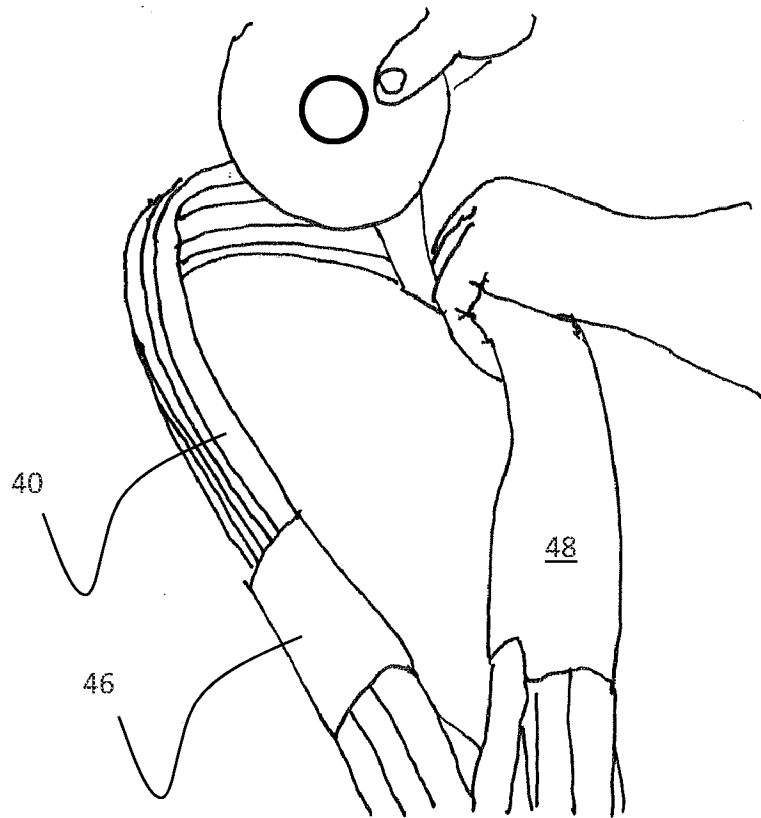
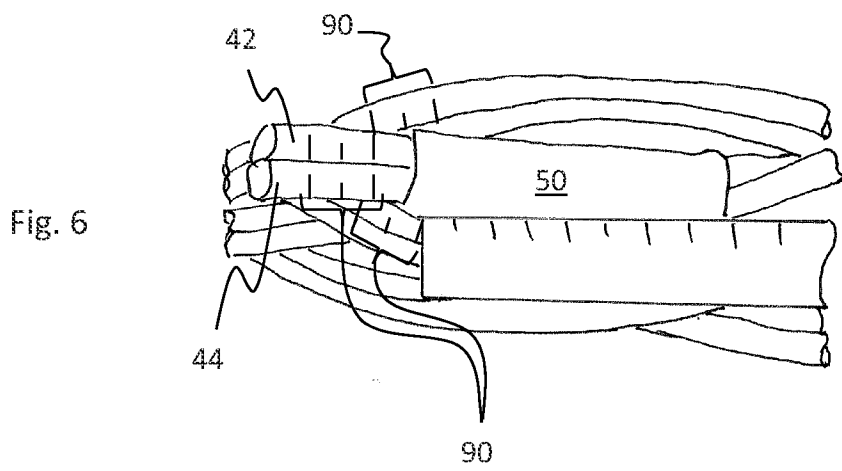
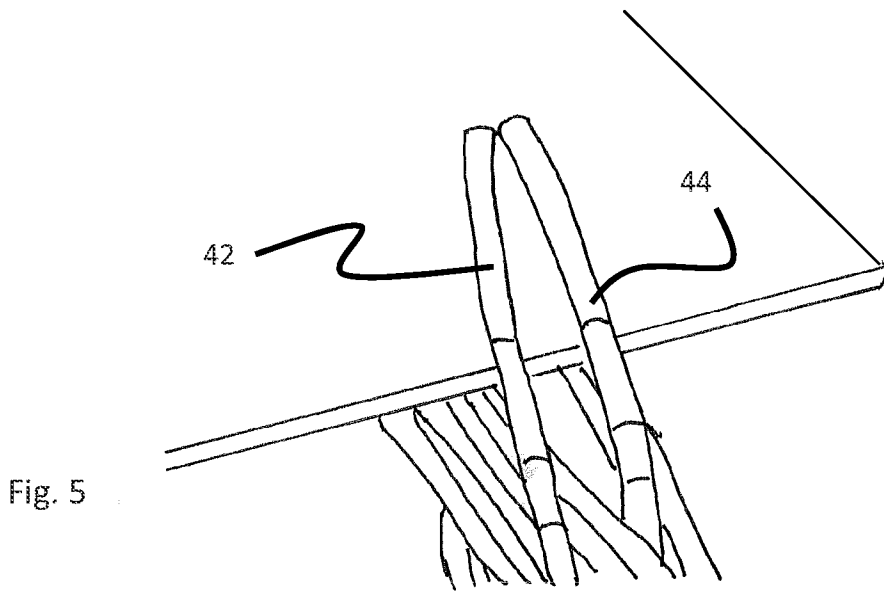

Fig. 4

4/5



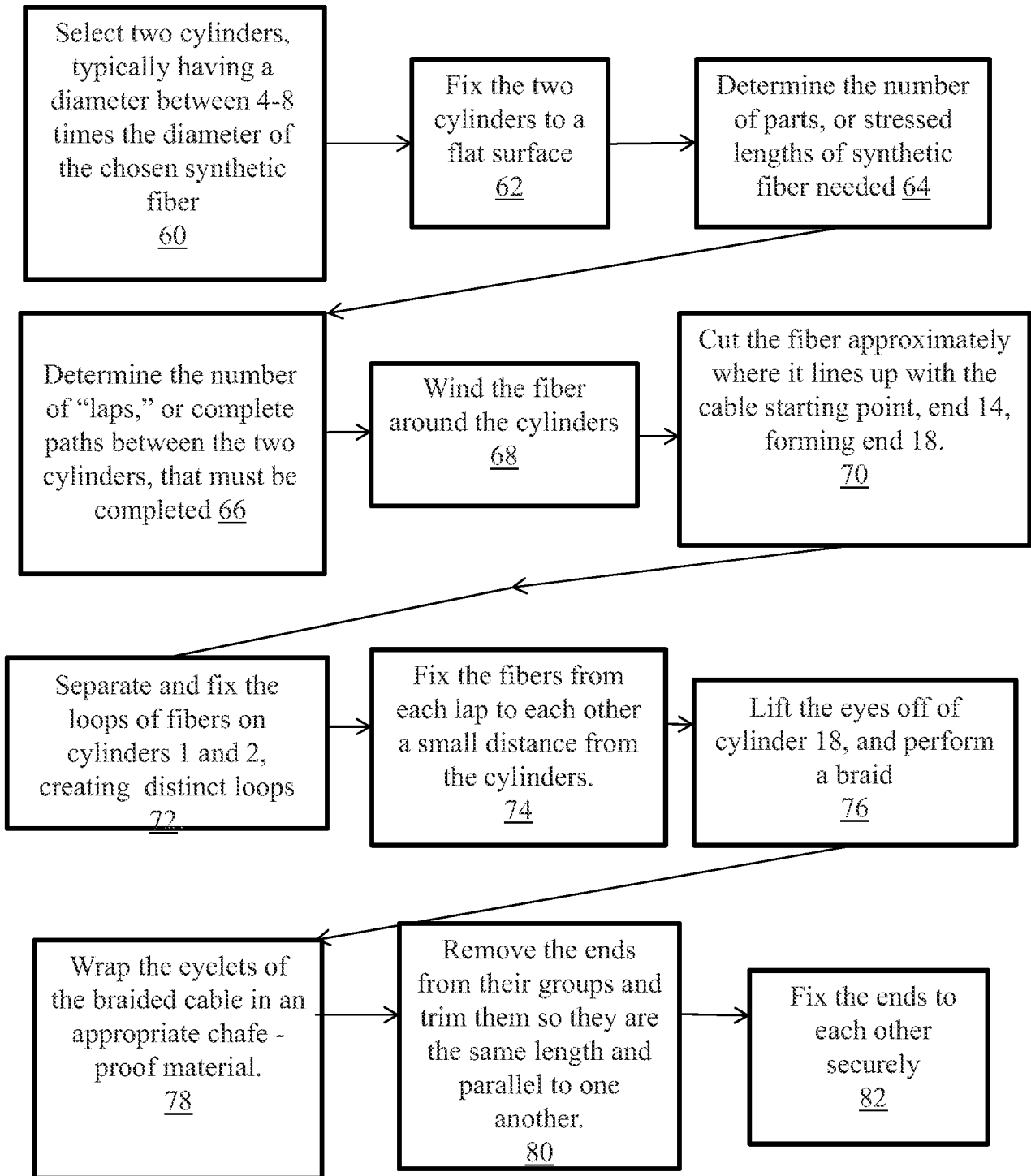

Fig. 7

A. CLASSIFICATION OF SUBJECT MATTER**B66C 1/12(2006.01)i**

According to International Patent Classification (IPC) or to both national classification and IPC

B. FIELDS SEARCHEDMinimum documentation searched (classification system followed by classification symbols)
B66C 1/12; D07B 1/02; B66C 1/18Documentation searched other than minimum documentation to the extent that such documents are included in the fields searched
Korean utility models and applications for utility models
Japanese utility models and applications for utility modelsElectronic data base consulted during the international search (name of data base and, where practicable, search terms used)
eKOMPASS(KIPO internal) & Keywords: sling, woven, loop, wrap, and cover**C. DOCUMENTS CONSIDERED TO BE RELEVANT**

Category*	Citation of document, with indication, where appropriate, of the relevant passages	Relevant to claim No.
X	KR 10-2011-0110414 A (LEE, JAE-HO) 7 October 2011 See abstract, claim 1, and figure 1.	1, 5, 12-14, 17, 18
A		2-4, 6-11, 15, 16, 19, 20
A	US 4043581 A (ST. GERMAIN, DENNIS) 23 August 1977 See abstract, claims 1, 2, and figure 2.	1-20
A	KR 20-2012-0002560 U (JOO, SANG-HYUN) 16 April 2012 See abstract, claim 1, and figure 1.	1-20
A	US 7399018 B1 (KHACHATURIAN, JON E.) 15 July 2008 See abstract, claim 1, and figure 1.	1-20
A	US 4025100 A (BRIDGEHOUSE, SCOTT) 24 May 1977 See abstract, claim 1, and figure 1.	1-20

 Further documents are listed in the continuation of Box C. See patent family annex.

* Special categories of cited documents:

"A" document defining the general state of the art which is not considered to be of particular relevance

"E" earlier application or patent but published on or after the international filing date

"L" document which may throw doubts on priority claim(s) or which is cited to establish the publication date of another citation or other special reason (as specified)

"O" document referring to an oral disclosure, use, exhibition or other means

"P" document published prior to the international filing date but later than the priority date claimed

"T" later document published after the international filing date or priority date and not in conflict with the application but cited to understand the principle or theory underlying the invention

"X" document of particular relevance; the claimed invention cannot be considered novel or cannot be considered to involve an inventive step when the document is taken alone

"Y" document of particular relevance; the claimed invention cannot be considered to involve an inventive step when the document is combined with one or more other such documents, such combination being obvious to a person skilled in the art

"&" document member of the same patent family

Date of the actual completion of the international search

16 July 2014 (16.07.2014)

Date of mailing of the international search report

17 July 2014 (17.07.2014)

Name and mailing address of the ISA/KR

International Application Division
Korean Intellectual Property Office
189 Cheongsu-ro, Seo-gu, Daejeon Metropolitan City, 302-701,
Republic of Korea

Facsimile No. +82-42-472-7140

Authorized officer

KIM, Jin Ho

Telephone No. +82-42-481-8699



INTERNATIONAL SEARCH REPORT

Information on patent family members

International application No.

PCT/US2014/027232

Patent document cited in search report	Publication date	Patent family member(s)	Publication date
KR 10-2011-0110414 A	07/10/2011	None	
US 4043581 A	23/08/1977	None	
KR 20-2012-0002560 U	16/04/2012	None	
US 7399018 B1	15/07/2008	None	
US 4025100 A	24/05/1977	None	