

G. H. CARPENTER.
Millers' Red Staffs.

No. 133,696.

Patented Dec. 10, 1872.

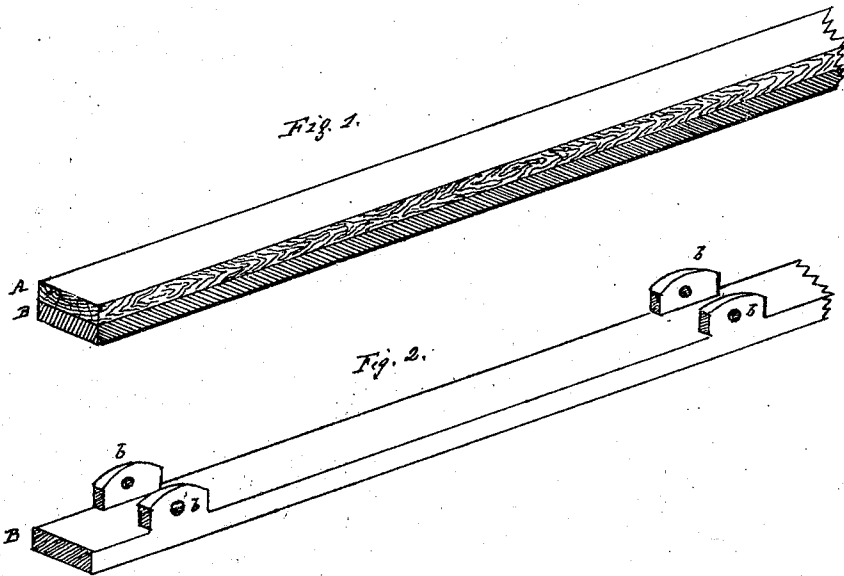

Witnesses.

John Bender
W. B. Wishing

Inventor.

George H. Carpenter
J. Stauffer Att'y.

UNITED STATES PATENT OFFICE.

GEORGE H. CARPENTER, OF WARWICK TOWNSHIP, (NEAR LITIZ,) LANCASTER COUNTY, PENNSYLVANIA.

IMPROVEMENT IN MILLERS' RED STAFFS.

Specification forming part of Letters Patent No. 133,696, dated December 10, 1872.

To all whom it may concern:

Be it known that I, GEORGE H. CARPENTER, of Warwick Township, near Litiz, in the county of Lancaster and State of Pennsylvania, have invented a certain Improvement on a Straight or Red Staff, of which the following is a specification:

The object of this invention is to obviate the necessity and expense incurred in dressing or readjusting the straight or red staff heretofore in use by millers for the purpose of indicating the harder or higher portions on the face of millstones, by carefully moving the colored staff over it so as to leave its mark at those points.

In the drawing, Figure 1 shows an ordinary red-staff, A, with its under side faced with iron, B, which latter is novel and of the greatest utility; and Fig. 2 shows a cast face with side lugs b.

It is well known that in consequence of a difference in the quality of millstones the harder portions require cutting down very frequently so as to give the face its true level. In order to indicate those points which are higher it is customary to have a straight staff, made of specially-selected wood, which has its lower face made red by paint or red keel mixed with water. This staff is then carefully moved in every direction over the stone, and leaves its red markings to indicate the higher points on its face.

It is found that the best wood, when made

wet and used and set aside, will warp more or less, so as to require dressing every time it is brought into requisition. It is further found that particles of sand are ground into the pores of the wood, highly injurious to the plane-bit, so as to make it both tedious and expensive to redress and be readjusted by means of the proof-staff, which is usually made of iron, and especially used as a test or proof staff, and too costly to be used for a red staff. To obviate this tendency to warp and the necessity to redress, as well as to enable me to use any kind of wood suitable for the purpose, I line the under side of the staff with iron—say three-fourths of an inch thick—either wrought-iron affixed with screws, countersunk, or cast with a flange or ears, b, let into the sides of the wood, thus giving it the ordinary size, but provided with a metallic face.

I do not claim a wooden straight or red staff, nor do I claim an iron proof-staff, for such are common; but I am not aware that a red staff faced with iron was ever before known or used. Therefore,

What I claim is—

A marking or so-called red staff faced with iron, substantially in the manner and for the purpose specified.

GEORGE H. CARPENTER.

Witnesses at signing:

JOHN KAHL,
A. B. REIDENBACH.