

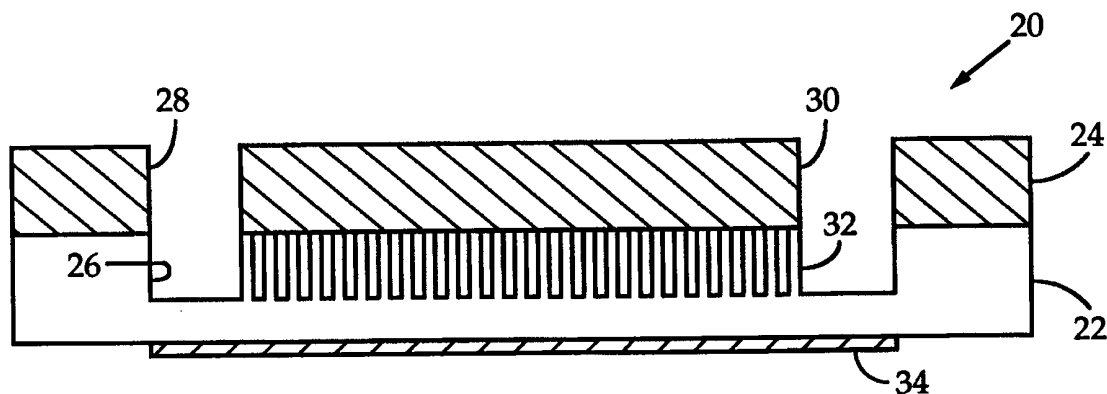

INTERNATIONAL APPLICATION PUBLISHED UNDER THE PATENT COOPERATION TREATY (PCT)

<p>(51) International Patent Classification⁶ : C07H 1/00</p>	<p>A2</p>	<p>(11) International Publication Number: WO 99/09042</p> <p>(43) International Publication Date: 25 February 1999 (25.02.99)</p>
<p>(21) International Application Number: PCT/US98/16870</p> <p>(22) International Filing Date: 13 August 1998 (13.08.98)</p> <p>(30) Priority Data: 08/910,434 13 August 1997 (13.08.97) US 09/115,454 14 July 1998 (14.07.98) US</p> <p>(71) Applicant: CEPHEID [US/US]; 1190 Borregas Avenue, Sunnyvale, CA 94089 (US).</p> <p>(72) Inventors: CHRISTEL, Lee, Allan; 3747 La Donna Street, Palo Alto, CA 95306 (US). KOVACS, Gregory, T., A.; 105 Peter Coutts Circle, Stanford, CA 94305 (US). MCMILLAN, William, A.; 8051 Presidio Drive, Cupertino, CA 95014 (US). NORTHRUP, M., Allen; 923 Creston Road, Berkeley, CA 94708 (US). PETERSEN, Kurt, E.; 3655 Valley Ridge Lane, San Jose, CA 95148 (US). POURAHMADI, Farzad; 41013 Pajaro Drive, Fremont, CA 94539 (US).</p> <p>(74) Agents: CHOW, Y., Ping et al.; Heller Ehrman White & McAuliffe, 525 University Avenue, Palo Alto, CA 94304-1900 (US).</p>		<p>(81) Designated States: AL, AM, AT, AU, AZ, BA, BB, BG, BR, BY, CA, CH, CN, CU, CZ, DE, DK, EE, ES, FI, GB, GE, GH, GM, HR, HU, ID, IL, IS, JP, KE, KG, KP, KR, KZ, LC, LK, LR, LS, LT, LU, LV, MD, MG, MK, MN, MW, MX, NO, NZ, PL, PT, RO, RU, SD, SE, SG, SI, SK, SL, TJ, TM, TR, TT, UA, UG, UZ, VN, YU, ZW, ARIPO patent (GH, GM, KE, LS, MW, SD, SZ, UG, ZW), Eurasian patent (AM, AZ, BY, KG, KZ, MD, RU, TJ, TM), European patent (AT, BE, CH, CY, DE, DK, ES, FI, FR, GB, GR, IE, IT, LU, MC, NL, PT, SE), OAPI patent (BF, BJ, CF, CG, CI, CM, GA, GN, GW, ML, MR, NE, SN, TD, TG).</p> <p>Published <i>Without international search report and to be republished upon receipt of that report.</i></p>

(54) Title: MICROSTRUCTURES FOR THE MANIPULATION OF FLUID SAMPLES



(57) Abstract

The invention presents a microfluidic device and method for separating a desired material, such as nucleic acid, from other materials in a fluid sample. In a preferred embodiment, the device comprises a microfabricated chip (20) having an inlet port (28), an outlet port (30), and an extraction chamber (26) in fluid communication with the ports. The chamber (26) has internal attachment surfaces for capturing the desired material from the fluid sample as the sample flows continuously through the chamber. The captured material may then be eluted by forcing an elution fluid to flow through the chamber (26), thus releasing the material from the internal surfaces into the elution fluid. The flow-through design of the device allows target material from a relatively large volume of fluid sample to be concentrated into a much smaller volume of elution fluid. The internal surfaces are preferably formed by an array of columns (32) integrally formed with a wall of the chamber (26) and extending into the chamber (26). The columns (32) provide a large surface area for capturing the desired material. The device also preferably includes an integrated heater (34) for increasing elution efficiency.

FOR THE PURPOSES OF INFORMATION ONLY

Codes used to identify States party to the PCT on the front pages of pamphlets publishing international applications under the PCT.

AL	Albania	ES	Spain	LS	Lesotho	SI	Slovenia
AM	Armenia	FI	Finland	LT	Lithuania	SK	Slovakia
AT	Austria	FR	France	LU	Luxembourg	SN	Senegal
AU	Australia	GA	Gabon	LV	Latvia	SZ	Swaziland
AZ	Azerbaijan	GB	United Kingdom	MC	Monaco	TD	Chad
BA	Bosnia and Herzegovina	GE	Georgia	MD	Republic of Moldova	TG	Togo
BB	Barbados	GH	Ghana	MG	Madagascar	TJ	Tajikistan
BE	Belgium	GN	Guinea	MK	The former Yugoslav Republic of Macedonia	TM	Turkmenistan
BF	Burkina Faso	GR	Greece			TR	Turkey
BG	Bulgaria	HU	Hungary	ML	Mali	TT	Trinidad and Tobago
BJ	Benin	IE	Ireland	MN	Mongolia	UA	Ukraine
BR	Brazil	IL	Israel	MR	Mauritania	UG	Uganda
BY	Belarus	IS	Iceland	MW	Malawi	US	United States of America
CA	Canada	IT	Italy	MX	Mexico	UZ	Uzbekistan
CF	Central African Republic	JP	Japan	NE	Niger	VN	Viet Nam
CG	Congo	KE	Kenya	NL	Netherlands	YU	Yugoslavia
CH	Switzerland	KG	Kyrgyzstan	NO	Norway	ZW	Zimbabwe
CI	Côte d'Ivoire	KP	Democratic People's Republic of Korea	NZ	New Zealand		
CM	Cameroon		Republic of Korea	PL	Poland		
CN	China	KR	Republic of Korea	PT	Portugal		
CU	Cuba	KZ	Kazakstan	RO	Romania		
CZ	Czech Republic	LC	Saint Lucia	RU	Russian Federation		
DE	Germany	LI	Liechtenstein	SD	Sudan		
DK	Denmark	LK	Sri Lanka	SE	Sweden		
EE	Estonia	LR	Liberia	SG	Singapore		

5

MICROSTRUCTURES FOR THE MANIPULATION OF FLUID SAMPLES**RELATED APPLICATION INFORMATION**

This application claims priority from U.S. application Ser.
10 No. 08/910,434 filed August 13, 1997 and from U.S.
application Ser. No. 09/115,454 filed July 14, 1998.

FIELD OF THE INVENTION

The present invention pertains generally to the processing
15 of fluid samples, and in particular to a novel method and
microfluidic device for the manipulation of materials,
including macromolecules such as proteins, nucleic acids,
and other moieties, in fluid samples.

20

BACKGROUND OF THE INVENTION

In many fields of molecular biology and biomedical
diagnostics, there is a great need for efficient methods and
techniques for extracting, isolating, and concentrating
target materials, such as nucleic acids, from complex
25 biological samples. Examples of these fields include
processing of large volume medical, industrial, and
environmental samples, such as food, water, blood, tissues,
sputum, urine, industrial fluids, and soil. The samples may
be used for genetic analysis, e.g., sequencing, pathogen
30 identification and quantification, nucleic acid mutation
analysis, genome analysis, as in assessment of organ
compatibility for transplantation, gene expression studies,
pharmacological monitoring, generation and verification of
DNA libraries for drug discovery, etc.

35

One conventional bench-top technique for extracting nucleic
acid from a fluid sample involves mixing the sample with
chaotropic salts and silica particles, such as particles of
glass or diatomaceous earth. This technique is described in
40 U.S. Patent 5,234,809 to Boom et al. and U.S. Patent
5,155,018 to Gillespie et al. DNA, RNA, and many proteins
naturally adhere and bind to silica surfaces. The

chaotropes cause the lysis of cells in the sample, enhance the binding of nucleic acids to silica, and denature proteins thereby inhibiting their adhesion to the silica. These salts also moderate the secondary structures of DNA and RNA, thus providing a favorable chemical environment for their adhesion.

The sample containing nucleic acid is mixed with the silica particles creating turbulence in the fluid sample, e.g. by shaking, in order to allow the nucleic acid to adhere to all surfaces. The adhesion of the nucleic acid to the silica particles results in the formation of silica-nucleic acid pellets. These pellets are then physically separated from the liquid, typically by centrifugation and disposal of the supernatant, e.g., by suction. The pellets are then washed to remove contaminants using, e.g., a vortex mixer, and sedimented again. Several additional washing steps may also be performed. Finally, the nucleic acid is eluted from the pellets using an aqueous solution buffer. These steps are typically performed manually on a bench top using a standard reaction vessel, e.g., a 1.5 mL conical tube.

Another bench-top technique for separating and purifying nucleic acid uses hydroxylated silica as the binding matrix. This technique is described in U.S. Patent 5,693,785 to Woodard et al. The hydroxylated silica allows for nucleic acid to be bound in an aqueous solution at room temperature and without the use of chaotropes. According to the method, a DNA-containing solution is incubated with the hydroxylated silica to allow binding of the DNA. The mixture is then centrifuged to obtain a pellet of hydroxylated silica with the bound DNA. The DNA is then eluted from the hydroxylated silica by resuspending the pellet in an eluting solution and heating at a temperature which is not destructive to DNA, typically 37 °C.

As an alternative to conventional bench-top assay techniques, attempts have been made to develop automated, microfluidic devices that perform some of these sample preparation and sample processing functions. As compared to bench-top assays, microfluidic systems have the potential of portability, improved reproducibility, reduced contamination, reduced reagent consumption, decreased operator intervention, and lower assay cost. Micromachining technology, e.g., using semi-conductor substrates, has enabled the manufacture of microfluidic devices for the manipulation, reaction, and detection of microliter to picoliter sample volumes. For example, U.S. Patent 5,639,423 to Northrup et al. discloses a microfabricated reactor for performing biochemical reactions, particularly DNA-based reactions such as the polymerase chain reaction.

Despite advances in microfluidic technology, however, there remains a need for a microfluidic device that can efficiently extract nucleic acid from a relatively large volume of fluid sample and concentrate the nucleic acid into a small volume for subsequent analytical processing. Very often, especially in diagnostic applications, it is necessary to extract and concentrate low concentrations of nucleic acids, for example, pathogenic organisms or cancerous cells, from relatively large sample volumes, e.g., several milliliters or more of fluid sample. This type of procedure is required, for example, in the detection of toxic E. coli O157 in food (toxic at levels of 1 organism/10 grams of food), HIV in blood (<200 viral organisms/ml of blood), anthrax in biowarfare scenarios (<100 organisms/liter of air), cancerous cells in blood or urine (<10 cells/ml of fluid), and sexually transmitted diseases (such as gonorrhea and chlamydia) in urine (<100 organisms/ml of fluid).

35

Unfortunately, currently existing microfluidic devices for the extraction and analysis of nucleic acid have focused on

picoliter, nanoliter, and microliter sample volumes. For example, Anderson et al. disclose such a microfluidic device for sample preparation and sample analysis in an article entitled "*Microfluidic Biochemical Analysis System*",

5 Transducers '97, 1997 International Conference on Solid-State Sensors and Actuators, Chicago, June 16-19, 1997, pg. 477-480.

The device disclosed by Anderson includes a 5 to 20
10 microliter chamber having a glass wall for separating nucleic acid from a fluid sample. In operation, the user first mixes the fluid sample with chaotropic salts to release DNA. The lysed sample is then injected into the chamber and allowed to incubate for 10 to 20 minutes to bind
15 nucleic acid in the fluid sample to the glass wall. Next, the fluid sample is ejected from the chamber, and the chamber is washed several times to remove contaminants. Finally, the nucleic acid is eluted from the chamber by filling the chamber with an elution solution and incubating
20 for 20 minutes at 50 °C.

Other existing microfluidic devices rely upon electrophoretic methods for separating nucleic acid from a fluid sample. Such devices generally include a separation
25 channel or chamber with electrodes disposed on opposite sides of the chamber. The chamber also typically includes an appropriate barrier, such as a filter or membrane, which allows for the passage of electrical current without allowing the passage of nucleic acids or other large
30 molecules. Upon application of an appropriate electric field, the nucleic acid present in a sample migrates toward the positive electrode and becomes trapped on the membrane. Sample impurities remaining free of the membrane are then washed from the chamber. Upon reversal of the voltage, the
35 nucleic acid is released from the membrane in a purer form. Such a microfluidic device for purifying nucleic acid is

described by Anderson et al. in International Publication Number WO 97/02357 published January 23, 1997 and by Sheldon et al. in International Publication Number WO 98/10277 published March 12, 1998.

5

A major disadvantage of the microfluidic devices described above is that they are relatively inefficient for extracting nucleic acid from a fluid sample, and they do not allow the nucleic acid from a relatively large volume of fluid sample
10 to be quickly and efficiently concentrated into a small volume of elution fluid. In particular, currently existing microfluidic devices are limited to a bolus processing approach in which a limited or defined volume of fluid sample is held in a chamber for incubation or

15 electrophoresis. As a result, the volume of fluid which can be processed by such devices is limited to the volume capacity of the chamber, typically picoliter, nanoliter, or microliter quantities.

20 Such small sample volumes are not practical for many realistic diagnostic applications. In particular, the detection of low copy nucleic acid, such as DNA, often requires sample volumes of several milliliters or more for accurate detection. Because existing microfluidic devices
25 are typically limited to processing picoliter, nanoliter, or microliter quantities, they are ineffective for many diagnostic applications involving nucleic acid. Of course, one possible approach is to build larger devices to accommodate larger volumes of fluid sample. If the devices
30 were fabricated using integrated circuit chip technologies, however, the microfabricated devices would have to be extremely large to accommodate the volume of sample needed to detect low concentrations of nucleic acid. Such large chips would not only be expensive, but would also defeat the
35 purpose of miniaturization, especially for many types of disposable medical or environmental diagnostic uses.

OBJECTS AND ADVANTAGES OF THE INVENTION

Accordingly, it is an object of the present invention to provide a microfluidic device and method for efficiently extracting a desired material from other materials in a fluid sample and for providing a highly concentrated eluate of the desired material. In particular, it is an object of the present invention to provide a flow-through device capable of separating nucleic acid from a relatively large volume of fluid sample and concentrating the nucleic acid into a much smaller volume of elution fluid. It is a further object of the invention to provide such a device with an integrated heater for increasing the efficiency of the extraction and elution processes.

These and other objects and advantages of the invention will be apparent upon consideration of the following description and the accompanying drawings.

SUMMARY

The present invention provides a novel method and device for the manipulation of materials in fluid samples. An exemplary use of the device of the present invention is for separating a desired material, such as nucleic acid, from other materials in a fluid sample and for providing a highly concentrated eluate of the desired material. The desired material may be, for example, nucleic acid, target cells, organisms, proteins, carbohydrates, virus particles, bacteria, chemicals, or biochemicals.

According to a first embodiment, the device comprises a body, preferably a microfabricated chip, having formed therein an inlet port for introducing the fluid sample into the body, an outlet port for exit of the fluid sample from the body, and an extraction chamber in fluid communication with the inlet and outlet ports for extracting the desired material from the fluid sample as the sample flows through

the body. The inlet and outlet ports are positioned to permit continuous fluid flow through the extraction chamber. The chamber has internal attachment surfaces having sufficiently high surface area and binding affinity with the desired material, e.g. nucleic acid, to capture the material as the sample flows through the chamber.

A preferred method of using the device to separate a desired material from other materials in a fluid sample includes the step of forcing the fluid sample to flow continuously through the chamber, thereby binding the desired material to the internal surfaces of the chamber. The fluid sample may be forced to flow through the chamber using any suitable fluid motive source, such as a pump, electro-osmotic force, electrophoretic force, pneumatic pressure, vacuum, or gravity. The captured material may then be eluted from the device by forcing an elution fluid to flow through the chamber, thus releasing the material from the internal surfaces into the elution fluid.

In contrast to prior art techniques, the volume of fluid sample forced to flow through the chamber is preferably greater than the volume capacity of the chamber. In particular, the flow-through device of the present invention allows target material from a relatively large volume of fluid sample, e.g., several milliliters or more, to be concentrated into a much smaller volume of elution fluid, e.g., 25 microliters or less. Extraordinary concentration factors from 10 to 100 are easily accomplished. The device also preferably includes a heater, such as a resistor coupled to a wall of the extraction chamber, for heating the chamber. Heating the chamber improves elution efficiency and may optionally be used to facilitate capture of the desired material.

In the preferred embodiment, the internal attachment surfaces for capturing the desired material are formed by an

array of internal microstructures, preferably high aspect ratio columns, integrally formed with at least one wall of the extraction chamber and extending into the chamber. The high aspect ratio columns provide a large surface area to which the desired material binds so that efficient extraction of the material occurs by the fluid sample flowing gently, i.e. by laminar flow, through the chamber. Thus, the microstructures permit a simple one-step extraction procedure. In contrast, some prior art techniques require a two-step procedure where a fluid sample and silica particles are first mixed by creating turbulent flow, such as by shaking, and then physically separated by techniques such as centrifugation. The microstructures of the present invention also provide an extremely efficient thermal interface from the chamber surfaces to the fluid.

The columns are preferably arranged in an array that maximizes fluid interaction with the surfaces of the columns as the fluid flows through the chamber. In the preferred embodiment, the columns are disposed in rows with each of the columns in a row spaced a uniform distance from adjacent columns in the row. In addition, adjacent rows are preferably offset from each other such that the columns in each row are misaligned, even slightly, with the columns in adjacent rows. Furthermore, in the preferred embodiment, the rows are arranged such that the columns in each row are misaligned with the columns in at least two previous or successive rows. The misalignment may be in a pattern of successive rows, where the chamber includes one pattern or a repeated pattern. For example, the pattern may repeat every three to ten rows. In the alternative, the misalignment of columns may be random from row to row. This offsetting of rows increases the interaction between the fluid and the surfaces of the columns by subdividing the fluid stream in such a way that all portions of the stream come within a very small distance of the columns as the fluid passes through the extraction chamber.

In alternative embodiments, the internal attachment surfaces may be formed by a solid support contained within the extraction chamber. Suitable solid supports for capturing target material include, for example, beads, fibers, membranes, glass wool, filter paper, and gels.

To ensure effective capture of the desired material, one or more internal surfaces of the chamber may be coated with a substance having a high binding affinity with the material. Suitable substances include, for example, silicon, silicon derivatives such as silicon dioxide, polymers, polymer derivatives such as polyamides, nucleic acids, certain metals, polypeptides, proteins, polysaccharides, or any other substance having a high binding affinity with the desired material.

The device of the present invention is preferably used in combination with a cartridge having a pre-processing site for the fluid sample and/or a post-processing site for the eluted material. By way of example, the pre-processing site may comprise a cell lysing area, precipitation area, or purification area for the pretreatment of fluid sample, and the post-processing site may comprise a capillary electrophoresis area, an isoelectric focusing area, a nucleic acid amplification area, a hybridization area, or an array of hybridization areas for the eluted material. In these embodiments, the device is constructed to be inserted into the cartridge such that the inlet port is in fluid communication with the pre-processing site and/or such that the outlet port is in fluid communication with the post-processing site.

The cartridge may optionally include or be coupled to one or more fluid motive sources, such as pumps, pneumatic pressure sources, or vacuums, for forcing the fluid sample to flow through the extraction chamber. The cartridge may also

include or be connected to processing electronics, e.g., one or more microprocessors, multiplexers, power control circuits, and sensor circuits, for controlling the operation of the cartridge.

5

BRIEF DESCRIPTION OF THE DRAWINGS

FIGS. 1A-1H are scanning electron micrographs of devices of this invention exemplifying different arrays of microstructures etched in silicon.

- 10 FIG. 1A shows an array of microcolumns disposed in a chamber having inlet and outlet ports.
- FIG. 1B is a magnified view of a portion of the array of microcolumns of FIG. 1A.
- FIG. 1C shows a different array of microcolumns having
15 pointed ends.
- FIG. 1D shows a single row of microstructures forming a filter at one end of a chamber.
- FIG. 1E is a micrograph showing six channels converging into a common channel.
- 20 FIG. 1F shows two channels merging into a common channel having a series of pillars disposed therein.
- FIG. 1G shows another channeled device suitable for liquid phase separation.
- FIG. 1H shows a hydrodynamic focusing device useful for
25 flow cytometry.
- FIG. 2 is a three-dimensional view of a device having two deep channels merging into one common channel for diffusion mixing of two fluids.
- FIG. 3 is a three-dimensional view of another device
30 having two deep channels merging into one common channel for diffusion mixing of two fluids.
- FIG. 4 is a schematic plan view of a device having a network of merging channels providing multiple interdiffusion regions for fluids.
- 35 FIG. 5 is a three-dimensional view of an alternative device having two channels that merge into a

common channel having a series of pillars disposed therein.

FIG. 6 is a schematic, cross sectional view of a flow-through device for extracting a desired material from a fluid sample according to a preferred embodiment of the invention.

FIG. 7 is a bottom plan view of the device of FIG. 6.

FIG. 8 is a three-dimensional view of microcolumns formed in an extraction chamber of the device of FIG. 6.

FIG. 9 is a schematic, plan view of the microcolumns in the device of FIG. 6.

FIG. 10 is a plan view of two adjacent microcolumns in the device of FIG. 6.

FIG. 11 is a schematic view of an etch mask defining a chamber pattern and a column pattern used in the fabrication of the device of FIG. 6.

FIG. 12 is a schematic plan view of a cartridge containing the device of FIG. 6 according to the preferred embodiment of the invention.

FIG. 13 is a schematic, cross sectional view of a flow-through device for extracting a desired material from a fluid sample according to an alternative embodiment of the invention.

FIG. 14 is a schematic, cross sectional view of a flow-through device for extracting a desired material from a fluid sample according to another embodiment of the invention.

FIG. 15 is a schematic, cross sectional view of a flow-through device for extracting a desired material from a fluid sample according to a further embodiment of the invention.

DETAILED DESCRIPTION

The present invention addresses certain aspects of controlling, moving, or otherwise manipulating fluids on a microscale. Microfluidic systems that may be useful for fully automated biochemical analysis require that specific

functionalities such as volume measuring, fluid mixing, heating, liquid phase separation, and others, be incorporated into microfluidic circuits. They must be designed to overcome microscale effects, such as low Reynolds numbers, that make conventional macroscopic design approaches ineffective.

Mixing of fluids is a common and critical event in most biochemical analytical protocols. On a conventional macroscale, there are various effective means, including pipettors, vortexing devices, or aspirating/dispensing robotics, to effect mixing of two or more fluids. However, it is well known that mixing of fluids in microfluidic systems is difficult. The problem stems from the fact that the Reynolds numbers are typically so small (less than 100) in most microfluidic systems, that the flows are virtually always laminar. Reynolds number is $([\text{density} \times \text{velocity} \times \text{channel width}] / \text{viscosity})$. In microfluidic systems, the channel width is so small that the Reynolds number is small. In macroscopic systems, Reynolds number must be above about 2300 before turbulence begins. Since fluid flow is virtually never turbulent in microfluidic systems, mixing occurs almost entirely by diffusion. Mixing by diffusion can be very slow. One example is that of a 300 μm deep by 600 μm wide "zigzagging" channel, which fully mixes fluids only after a flow length of 100 mm.

Besides mixing, other techniques are required in biochemical analysis. For example, one well-accepted technique for extracting proteins and other hydrophobic chemicals from aqueous solutions containing biological compounds is liquid phase separation. Proteins, normally present in high concentration in aqueous biological solutions such as serum, plasma, and tissue homogenates, are structurally composed of both hydrophobic and hydrophilic domains that together determine their secondary and tertiary structure as a

function of the solvent in which they are dissolved. Although the hydrophobic domains are usually much larger than the hydrophilic domains, stable structures are achieved in polar solvents when the hydrophobic domains self-
5 associate in the core of the globular structure and the hydrophilic are exposed to the solvent. This satisfies the difference in Gibbs free energy state between folded and unfolded structures as a function of the solvent properties. However, conditions can be produced in the aqueous phase
10 such that in most cases, limited only by extremes of salt concentration and pH or presence of denaturants or detergents, a lower Gibbs free energy state for the protein can be achieved in non-polar solvents, such as alcohols, various alkanes, and chloroform.

15

The preferential partitioning, migration, or diffusion of proteins from polar to non-polar solvents can be exploited to extract proteins from polar-based biological samples. When a non-polar liquid, for example chloroform, is added to
20 a water-based solution, the fluids will not mix, but will remain in two immiscible phases. The less dense non-polar phase will rise to and remain as a separate layer on top of the polar phase. A small number of proteins in the polar phase can undergo a change in tertiary structure and move
25 across the boundary between the two phases because they favor the lower energy state associated with being dissolved in the non-polar phase. Over a very long period of time, the polar phase becomes depleted of proteins. If the immiscible fluids are vigorously agitated, the solutions
30 will form an emulsion. In such an emulsion, the non-polar phase will form into a large number of small droplets, surrounded by and evenly distributed throughout the polar phase, for example. This dramatically increases the effective surface area between the two phases for the
35 interaction of the proteins with the non-polar phase and their diffusion into the non-polar phase. The rate of movement of proteins into the non-polar phase can also be

enhanced by varying the conditions in the polar phase which decrease their structural stability in the polar phase. The presence of high salt concentration, detergents, phenol, and/or chaotropes can decrease the stability of the folded state of proteins in the polar phase.

After the emulsion is allowed to stand still for some time without agitation, or with assistance by increased relative centrifugal force (if there is a density difference between the two phases), the two phases will eventually separate again, with the non-polar phase forming a layer over the top of the polar phase. Now, the non-polar phase is highly concentrated with proteins and the polar phase is depleted of proteins. If the original protein concentration is very high, residual proteins may still be present in the polar phase due to back diffusion, and fresh non-polar solvent must be added and the separation repeated. Similar phase separation methods have been used to separate proteins from water-based biological solutions for many years.

The present invention provides microdevices suitable for generating very large microfluidic interfaces useful for effecting fast, efficient mixing of fluids or for creating an artificial emulsion that provides a means for performing the same protein extraction function as the traditional agitation-based liquid phase separation methods. For the purpose of generating structures capable of efficient mixing of fluids, new processing technologies have become available for creating micromachined, microfluidic channels. The process known as deep reactive ion etching (DRIE) enables the formation of channels that are very deep, yet surprisingly narrow. With this process, fast diffusion mixing can be realized by causing two fluids to flow in deep, vertical channels and by merging them together, thereby creating two thin vertical sheaths that will mix by diffusion over a much shorter distance than in traditional types of channels.

Microchannel geometries that exploit the DRIE process can be designed to support liquid phase separation processes. As shown in FIGS. 1-5, fluid channels may be formed in a solid substrate in a wide variety of geometries. FIG. 2 shows a device having two deep channels 70 and 72 converging into a common channel 74. The channels are etched in a silicon substrate using DRIE. Each channel has a depth 73 greater than its width 75, providing a surface area ratio of greater than 3:1. Fluids flowing through the separate channels 70 and 72 merge to form two thin fluid sheaths flowing side-by-side in the common channel 74. The large depth of the channels relative to their width provides a large interfacial area between the fluid streams for diffusion mixing of the two fluids. FIG. 1E is a scanning electron micrograph of a similar device having six deep channels that merge into a single common channel. Fluids flowing through the separate channels merge to form six fluid sheaths flowing side-by-side in the common channel.

FIG. 3 shows another device having two deep channels 70 and 72 for carrying two immiscible fluid streams (polar and non-polar solvents). The channels 70 and 72 merge in the contact region 80. Since the fluids are immiscible, they flow alongside each other throughout the region 80, then exit, respectively, into their corresponding channels 76 and 78. During the time the fluids are in the contact region 80, molecules dissolved in one fluid, but which have partition coefficients favoring the other fluid, will diffuse between the fluids even though the two immiscible fluids do not themselves mix.

FIG. 4 illustrates a device having a network of channels 70, 72, 76, and 78 that merge to form multiple contact regions 80, increasing fluid contact time. The increased contact time increases particle diffusion. The region 85 shows the fluid paths making a 180 degree turn to increase the total path length on a single substrate.

The channels of the above devices have an internal/facial surface area ratio greater than 3:1. As used herein, the term "internal surface area" refers to the total surface area of the interior of the channel including the surface area of any internal structures, such as pillars or microcolumns. In its simplest embodiment, the device of the invention comprises a single channel, so that the "internal surface area" is the summation of the surface areas of the two sidewalls and the bottom. In this embodiment, the depth of the channel is at least as great as its width to ensure a minimally high surface area ratio.

As used herein, the term "facial surface area" refers to the area on the face or surface of the substrate which has been removed to create the internal structure. In the example of the single channel, the "facial surface area" is that of the top of the channel. As used herein, the term "substantially greater" as applied to the ratio of the internal surface area to the facial surface area means greater than about 3:1, preferably greater than about 5:1, more preferably greater than about 10:1, and most preferably greater than about 20:1. Typical dimensions for the channels will be 10 to 1,000 μm deep and 5 to 50 μm wide. Although many different methods can be used to form the channels, one preferred method is deep reactive ion etching of a silicon substrate.

The channels are arranged such that two or more separate channels (each carrying one of the immiscible fluids)

intersect and are merged into a single channel. The maximum value for this merged distance will depend on many factors such as the polarity of each of the fluids, the hydrophobicity/hydrophobicity of the inside surfaces of the channels, the degree of immiscibility of the fluids and their surface tensions, the fluid stability of the two thin fluid sheaths flowing side-by-side, their relative flow rates and viscosity, and many other factors. Assuming relatively stable fluid sheaths, turbulent mixing is precluded because of low Reynolds numbers. After this distance, the merged channel is preferably split into two or more channels, allowing the two or more immiscible fluid streams to separate again.

During the time and distance over which the two independent streams are merged and in contact at the interface, proteins and other hydrophobic solutes at the interface will diffuse across the interface into the non-polar fluid stream. When the two streams first make contact, the proteins are uniformly distributed throughout the polar fluid. As the fluids traverse the common channel, however, the protein concentration in the polar fluid at the interface of the two fluid streams begins to decrease as proteins move across the interface into the non-polar fluid, forming a depletion zone in the polar fluid at the interface and a concentration gradient across the width of the polar fluid stream. The rate at which the depletion zone is replenished is a function of the concentration gradient formed and of the solute diffusion coefficients, which can vary for different proteins. Since the width of the polar stream is typically very small, the replenishment rate of the depletion zone is very fast, so that more and more proteins are absorbed into the non-polar stream as the fluids traverse the contact region. After the fluid streams exit the common channel, the proteins remaining in the polar stream will equilibrate toward a uniform distribution again. The total concentration of proteins, however, will have decreased.

If many such diffusion regions are arranged in series, increased levels of proteins will be removed from the polar stream and will be absorbed by and dissolved into the non-polar stream. Very many diffusion regions may be incorporated into a small microfabricated element, such as a silicon chip. For typical geometries indicated here, at least 50 diffusion regions/mm² of chip surface area are possible.

10

Many variations on this concept are possible. For example, depending on the stability of the fluid streams in contact with each other, it may be possible to have a very long diffusion region, with no equilibration regions. In this case, the fluid flow could be "flat" on the surface of the element. On the other hand, if the stability of the fluid streams is very low, it is possible to provide additional very small microcolumns or "pillars" along the contact region (like miniature jail bars) to further reduce the tendency of the fluids to mix or the streams to become unstable. FIG. 5 shows such a device having pillars 91

15

disposed in the common channel to increase the stability of the fluid streams. FIGS. 1F-1G are scanning electron micrographs showing more examples of such devices. It should also be noted that the devices may be used for reverse operation, i.e., to separate fluid flowing in a common channel into multiple, separate fluid streams for further downstream processing. For example, the device of FIG. 1E may be used to separate the fluid flowing in the common channel into six separate fluid streams.

20

25

FIG. 1H shows a hydrodynamic focusing device according to the present invention that is useful for flow cytometry. The device includes an inlet port and two side channels located on opposite sides of the port. The inlet port and side channels merge into a common channel. In operation, a

30

fluid sample may be added to the inlet port and reagents or focusing fluid may be caused to flow through the side channels. The fluid flowing through the side channels forces the fluid sample to flow in a center stream in the common channel, thus focusing the fluid sample. The device
5 may also include an optical detector positioned adjacent the common channel for detecting properties of the fluid sample.

A great degree of flexibility is achieved by the ability to
10 modify the surfaces of the channels in the above devices in order to increase the stability of the fluid streams and prevent physical mixing. For example, if the channel surfaces in the regions intended to carry the non-polar fluid are designed to be hydrophobic, then the tendency of a
15 polar fluid to flow inadvertently into the non-polar fluid, for example, as a result of accumulative small differences in flow rate and viscosity, is greatly reduced.

In addition to devices for liquid phase separation, the
20 present invention also provides methods and devices for separating a desired material from other materials in a fluid sample. The desired material may be, for example, nucleic acid, target cells, organisms, proteins, carbohydrates, virus particles, bacteria, chemicals, or
25 biochemicals.

An exemplary use of the device of the present invention is for the extraction, purification, and concentration of nucleic acid from a fluid sample. As used herein, the term
30 "nucleic acid" refers to any synthetic or naturally occurring nucleic acid, such as DNA, RNA, or PNA, in any possible configuration, i.e., in the form of double-stranded nucleic acid, single-stranded nucleic acid, or any combination thereof. As used herein, the term "fluid
35 sample" includes both gases and liquids, preferably the latter. The fluid sample may be an aqueous solution containing particles, cells, microorganisms, ions, or small

and large molecules, such as proteins and nucleic acids, etc. In a particular use, the fluid sample may be a bodily fluid, e.g., blood or urine, or a suspension, such as pulverized food. The fluid sample may be pretreated, for example, mixed with chemicals, centrifuged, pelleted, etc., or the fluid sample may be in a raw form.

A preferred embodiment of the invention is illustrated in FIGS. 6-12. FIG. 6 shows a schematic, cross sectional view of a microfluidic device 20 for extracting a desired material, e.g. nucleic acid, from a fluid sample and for providing a highly concentrated eluate of the material. The device 20 includes a body having formed therein an inlet port 28, an outlet port 30, and an extraction chamber 26 for extracting the nucleic acid from the fluid sample as the fluid sample flows through the body. The chamber 26 is in fluid communication with the inlet and outlet ports 28 and 30, and the ports are preferably positioned on opposite sides of the chamber 26 to permit continuous fluid flow through the chamber.

The body is preferably a microfabricated chip comprising a base substrate 22 and a top substrate 24 bonded to the base substrate 22. The substrates 22 and 24 may comprise any suitable substrate materials, such as silicon, glass, silicon dioxide, plastics, or ceramics. In the preferred embodiment, the extraction chamber 26 is formed in the base substrate 22, and the fluid ports 28 and 30 are formed in the top substrate 24. In alternative embodiments, however, many different configurations are possible, e.g., the chamber 26 may be partially or completely formed in the top substrate 24, the fluid ports may be formed in bottom or sides of the base substrate 22, etc. Several of these alternative embodiments will be described below.

The extraction chamber 26 has internal attachment surfaces having sufficiently high surface area and binding affinity with the nucleic acid to capture the nucleic acid as the fluid sample flows through the chamber. In the preferred embodiment, the internal attachment surfaces are formed by an array of internal microstructures, preferably high aspect ratio columns 32, integrally formed with a wall of the chamber 26 and extending into the chamber. For simplicity of illustration, only twenty-five columns are shown in the schematic view of FIG. 6. It is to be understood, however, that the device of the present invention may include many more columns. In general, it is preferred to fabricate the device with at least 100 columns, and more preferable to fabricate the device with 1,000 to 10,000 columns. The number of columns depends, *inter alia*, on the amount and concentration of nucleic acid in the sample, the dimensions of the chamber, the spacing of the columns, the flow rate of fluid through the chamber, etc. Specific techniques for fabricating the device are described below.

FIG. 8 shows a portion of the array of columns 32 extending from a bottom wall 23 of the extraction chamber. The columns 32 preferably have an aspect ratio (ratio of height to width or diameter) of at least 2:1, and more preferably have an aspect ratio of at least 4:1. The high aspect ratio columns 32 provide a large surface area for capturing the nucleic acid. As the fluid sample flows through the chamber, the nucleic acid contacts and adheres to the surfaces of the columns 32. To elute the nucleic acid, an elution fluid is forced to flow through the chamber, releasing the nucleic acid from the surfaces of the columns 32 into the elution fluid. In the preferred embodiment, the columns 32 have a height equal to the depth of the

extraction chamber, preferably at least 100 μm . In alternative embodiments, the extraction chamber may have a shallower depth, but depths of less than 100 μm may cause excessively slow fluid flow through the chamber.

5

FIG. 9 shows a schematic view of the array of columns 32 disposed in the chamber 26. Fluid enters the chamber 26 through the inlet port 28 and flows between the columns 32 to the outlet port 30. The columns 32 are preferably arranged in an array that optimizes fluid interaction with the surfaces of the columns as the fluid flows through the chamber 26. The optimization of the column arrangement permits faster flow rates of fluids through the chamber without losing efficiency of extraction.

10

In the preferred embodiment, the columns 32 are disposed in rows, with each of the columns in a row spaced a uniform distance from adjacent columns in the row, i.e. the columns in a row preferably have uniform center to center spacing.

15

For example, FIG.9 illustrates ten horizontal rows of uniformly spaced columns 32. In addition, adjacent rows are preferably offset from each other such that the columns in each row are misaligned with the columns in an adjacent row. For example, each row of columns in FIG. 9 is offset

20

horizontally from an adjacent row.

Also in the preferred embodiment, the rows are offset such that the columns in each row are misaligned with the columns in at least two previous and/or successive rows. The misalignment may be in a pattern of successive rows, where the chamber includes one pattern or a repeated pattern. For example, the pattern may repeat every three to ten rows. In the alternative, the misalignment of columns may be random from row to row.

25

30

35

Generally, any two adjacent rows in the array should not be offset from each other such that the columns in the first row are aligned exactly halfway between the columns in the second row. Instead, it is presently preferred to offset adjacent rows a distance greater than or less than 50% of the center to center spacing between the columns. This arrangement provides for an asymmetrically split flow pattern through the chamber to ensure that each branch of the fluid stream interacts as strongly as possible with the surfaces of the columns.

A specific example of a suitable arrangement of columns will now be given with reference to FIG. 9. In each row, the center to center spacing between adjacent columns is 15 μm . The columns are arranged in a pattern that repeats every five rows. In particular, each of the top five rows is offset 6 μm from a previous/and or successive row. The bottom five rows (the sixth through tenth rows) repeat the pattern of the top five rows, with the sixth row being aligned with the top row, e.g., column **32A** is aligned with column **32B**. Of course, this is just one example of a suitable array of columns and is not intended to limit the scope of the invention. It will be apparent to one skilled in the art from this description that the columns may be arranged in many other patterns, preferably within the general guidelines set forth above.

FIG. 10 shows a top plan view of two adjacent columns **32** in a row. The columns **32** preferably have a cross sectional shape and size which maximizes fluid contact with the surfaces of the columns while still allowing for smooth fluid flow through the chamber. In the preferred embodiment, this is achieved by fabricating columns having a long and thin cross sectional shape, preferably a streamlined shape, such as the hexagonal shapes shown in

FIG. 10. In particular, each column 32 preferably has a ratio of cross sectional length L to cross sectional width W of at least 2:1, and more preferably of at least 4:1. Further, the cross sectional length L is preferably in the range of 2 to 200 μm , and the cross sectional width W is preferably in the range of 0.2 to 20 μm .

The gap distance S between adjacent columns in a row is preferably selected to be as small as possible while still allowing fluid to flow between the columns without excessive resistance. In general, the gap distance S may range from 0.2 to 200 μm , and more preferably, is in the range of 2 to 20 μm . The range of 2 to 20 μm is currently preferred because it provides for substantial fluid contact with the surfaces of the columns without causing excessive resistance to the fluid flow through the chamber. The center to center spacing C between adjacent columns in a row is the sum of the cross sectional width W and gap distance S , and is preferably in the range of 2.0 to 40 μm .

The length of the extraction chamber 26, its vertical dimension in FIG. 9, is preferably in the range of 100 to 5000 μm , and more preferably at least 1000 μm . The width of the extraction chamber 26 is preferably in the range of 100 to 3000 μm . The fluid ports 28 and 30 each preferably have a width or diameter of at least 100 μm . It is presently preferred that the chamber 26 have a minimum length of 1000 μm to allow sufficient room for the array of columns 32 and for the fluid ports 28 and 30. In particular, it is presently preferred to confine the array of columns 32 to the center area of the chamber 26, leaving open space at the

ends of the chamber 26 where the fluid ports 28 and 30 join the chamber. This arrangement increases uniformity of fluid flow into the chamber 26 prior to the fluid flowing between the columns 32.

5

Referring again to FIG. 6, the internal surfaces of the chamber 26, e.g. the columns 32 and chamber walls, may be coated with a substance having a high binding affinity with the nucleic acid. Suitable substances include, for example, 10 silicon, silicon derivatives such as silicon dioxide, polymers, polymer derivatives such as polyamides, nucleic acids, certain metals, polypeptides, proteins, and polysaccharides.

15 The silicate (SiO_2) nature of glass can attract and bind nucleic acids. Silicon, when it becomes oxidized, results in a similar surface chemistry. Non-permanent (non-covalent) attachment (adsorption) to such a surface is typically based on weak dipole, hydrogen bonding, or ionic 20 interactions between the surface and moiety to be captured. These interactions are reversible via changes in the ionic nature of the solvent and/or surface, heat, or other physiochemical means. Many materials can be tailored to have a variety of interactions with solvents and solutes in 25 solution. Polymers can have active surface groups that provide specific interactive forces, and they can have copolymers or dopants that provide ionic or even hydrogen binding capabilities. Some polymers can have reversible polarities or adjustable conductivity. Synthetic and some 30 natural polypeptides and proteins have shown a similar capability to have a variety of interactions with solute molecules. Metals, such as gold, are well known to have the ability to capture DNA, and due to its electronic nature, can change the ionic interactions with solutes.

35

The internal surfaces of the chamber 26 may also be coated with a substance having a high binding affinity with a specifically targeted nucleic acid, e.g., a specific sequence of RNA from a virus or a specific sequence of DNA from a bacteria. This may be accomplished by coating the internal surfaces with a specific nucleic acid sequence complementary to the target nucleic acid sequence. The surfaces may be coated during manufacture of the device or immediately prior to use.

5

The microfluidic device 20 preferably includes a heater for heating the extraction chamber 26. The heater allows for highly efficient elution of the nucleic acid from the chamber so that a large amount of nucleic acid may be released into a small volume of elution fluid. The heater may also be used to facilitate capture of the nucleic acid. One advantage of the use of a heater in a small volume microchamber is that minimal energy is required to heat the device.

10

In general, the heater may comprise any suitable mechanism for heating the chamber 26, including resistive heaters, optical heaters for directing visible or infrared light, or electromagnetic heaters. If the body of the device 20 is fabricated from an electrically conductive material, preferably silicon, the heater may simply comprise a power source and electrodes for applying a voltage across a portion of the body forming the chamber 26. Also, high thermal conductivity of the material allows for fast heating times, reduced power requirements, and highly uniform temperatures. This embodiment is described in greater detail below.

In the preferred embodiment, the heater comprises a resistive heating element 34 coupled to the bottom wall of

15

the chamber 26. As shown in FIG. 8, the resistive heating element 34 is preferably a thin film of metal, carbon, or polysilicon that is patterned on the bottom surface of the substrate 22. Alternatively, the heating element may
5 comprise a laminated heater source, such as an etched foil-heating element, attached to the substrate 22. Electrically conductive bond pads 38A and 38B are also patterned on substrate 22 for electrically contacting opposite ends of the heating element 34.

10

The bond pads 38A and 38B may be connected by electrical leads to a power source for applying a voltage across the heating element 34. Control of the power source is preferably carried out by an appropriately programmed
15 controller, such as a computer, microprocessor, or microcontroller. The controller may be programmed to take the chamber 26 through any number of predetermined time/temperature profiles by varying the amount of power supplied to the heating element 34.

20

The microfluidic device also preferably includes one or more temperature sensors in communication with the controller for measuring the temperature of the extraction chamber 26. In general, the temperature sensor may be any suitable device
25 for measuring temperature, such as a thermocouple, resistance thermometer, thermistor, IC temperature sensor, quartz thermometer, or the like. Alternatively, the temperature coefficient of resistance of the heating element 34 may be utilized as a means to monitor the chamber
30 temperature and to control the heat input by measuring the resistance as indicative of temperature.

In the preferred embodiment, the temperature sensor comprises a strip 36 of electrically conductive material

patterned on the substrate **22**. The strip **36** comprises a material having an electrical resistance dependent on the temperature of the material, so that the temperature of the chamber **26** may be monitored by monitoring the resistance of the strip **36**. Electrically conductive bond pads **40A** and **40B** are also patterned on substrate **22** for electrically contacting opposite ends of the sensor strip **36**.

In an alternative embodiment, the substrate **22** may also have an additional bond pad **42** patterned thereon for providing a bulk contact to the substrate **22**. The bulk contact may be used to charge the internal attachment surfaces of the chamber **26** with a voltage to attract and/or elute nucleic acid. Suitable metals for forming the resistive heating element, sensor strip, and bond pads include aluminum, gold, silver, copper, and tungsten.

The bond pads **40A** and **40B** are connected by electrical leads to the controller, and the controller is preferably programmed to adjust the amount of power supplied to the heating element **34** in dependence upon the resistance of sensor strip **36**. The controller, power source, heating element, and temperature sensor thus form a closed loop temperature control system for controlling the temperature of the chamber **26**. Although a closed loop system is presently preferred, in alternative embodiments the temperature sensor may be eliminated and the device may be operated in an open loop mode. Further, the processing electronics, including e.g., one or more microprocessors, multiplexers, power control circuitry, and sensor circuitry, may be included in the device or located externally to the body of the device and connected thereto.

The microfluidic device of the present invention is preferably used in combination with a cartridge or similar device for the processing and analysis of fluid samples. Suitable cartridges with which the microfluidic device may be used are disclosed in U.S. application Ser. No. 08/998,188 filed December 24, 1997, the disclosure of which is incorporated by reference herein.

FIG. 12 shows an example of a cartridge 101 with which the microfluidic device of the present invention may be used. In this example, the cartridge 101 is designed to process a biological liquid sample and amplify nucleic acids, such as by polymerase chain reaction (PCR). The cartridge 101 includes a sample port 103 for introducing a fluid sample into the cartridge, a storage site 109 for storing a lysing reagent, and a storage site 125 for storing a washing reagent. The cartridge also includes a lysing site 107 for lysing of the fluid sample, a filter site 119 where the fluid sample contacts a filter to remove debris or cells from the sample, and a storage site 127 for storing elution fluid.

The cartridge is preferably fabricated with a well, recess, or depression for housing the microfluidic device 20. The device 20 is inserted into the cartridge 101 such that the inlet port of the device is in fluid communication with one or more pre-processing sites for the fluid sample, such as lysing site 107 and filter site 119. The outlet port of the device 20 is in fluid communication with a waste site 139 and a reagent site 141 which contains PCR reagents. Reagent site 141 is in fluid communication with a PCR reaction site 143 for PCR amplification and detection.

The cartridge **101** preferably includes flow controllers **123**, such as fluid diodes or valves, for controlling the flow of fluid through the cartridge. The cartridge **101** also preferably includes resistive sensors **115** for sensing the presence of fluid in various channels and sites. The cartridge **101** may also include or be coupled to an external fluid motive source for forcing fluid to flow through the cartridge. In general, the fluid motive source may comprise any suitable mechanism for forcing fluid to flow through the cartridge including pumps, pneumatic pressure sources, and vacuums. In the embodiment of FIG. 12, the fluid motive source comprises a plurality of electrolytic pumps or fluid filled pouches emptied by pneumatic, mechanical, or hydraulic pressure positioned in sites **103**, **109**, **125**, and **127**.

The cartridge **101** also includes processing electronics **151**, e.g., one or more microprocessors, multiplexers, power control circuits, and sensor circuits, for controlling the operation of the cartridge and microfluidic device **20**. The processing electronics **151** are connected by electrical leads **147** to various sites, storage areas, pumps, sensors, and channels in the cartridge. In particular, the leads **147** connect the processing electronics **151** to the bond pads of the microfluidic device **20** so that the temperature of the extraction chamber in the device may be precisely controlled.

Although the processing electronics **151** are physically located on the cartridge **101** in FIG. 12, it is to be understood that the processing electronic may be located externally to the cartridge, such as in a larger processing instrument into which the cartridge **101** may be inserted. In

this embodiment, the cartridge 101 preferably includes a thin, card-like section for electrically connecting the cartridge to a mating connector within the instrument, similar to the standard edge connectors used with printed circuit boards. Alternatively, there may be other data links of the cartridge to the instrument, such as radio frequency or infrared links.

In operation, a fluid sample containing nucleic acid is added to the sample port 103 of the cartridge and forced to flow continuously (such as with an electrolytic or mechanical pump) down a channel 105 and into the lysing site 107. Lysing reagents are simultaneously released from the storage site 109 and forced to flow down a channel 111 and into the lysing site 107. Suitable lysing reagents include, for example, solutions containing a chaotropic salt, such as guanidine HCl, guanidine thiocyanate, guanidine isothiocyanate, sodium iodide, urea, sodium perchlorate, and potassium bromide.

The fluid sample and lysing reagents traveling in the channels 105 and 111, respectively, are detected by resistive sensors 115. As the lysing reagent contacts the fluid sample flowing through the lysing site 107, cells present in the fluid sample are lysed. The fluid sample and lysing reagent continue to flow into the filter site 119 where the sample contacts a filter and debris is removed from the fluid sample. The fluid sample and lysing reagent proceed from the filter site 119 down channel 121 and are forced to flow continuously through the microfluidic device 20.

Referring again to FIG. 9, as the fluid sample and lysing reagent flow through the extraction chamber 26, nucleic acid

in the fluid sample binds to the chamber walls and to the surfaces of columns 32 while excess material flows out of the chamber 26 through the outlet port 30. The flow rate of the fluid sample through the chamber 26 is preferably in the
5 range of 0.1 to 50 $\mu\text{L}/\text{sec}$. Referring again to FIG. 12, the fluid sample and lysing reagent exiting the device 20 flow down a channel 135, through a flow controller 41A, and through a channel 136 to the waste site 139. In another
10 embodiment, after flowing through the chamber, the fluid sample may be redirected to recirculate through the chamber additional times.

After the fluid sample is forced to flow through the device 20, the washing reagent in storage site 125 is forced to
15 flow down a channel 129 and through the device 20. The preferred wash flow rate is about 0.5 to 50 $\mu\text{L}/\text{sec}$. Fluid is prevented from flowing upstream in the cartridge by flow controllers 123 in channels 121, 129, and 131. The washing reagent washes residual contaminants, such as chaotropic
20 salts, from the internal attachment surfaces of the device 20. A variety of suitable wash solutions of varying pH, solvent composition, and ionic strength may be used for this purpose and are well known in the art. For example, a suitable washing reagent is a solution of 80mM potassium
25 acetate, 8.3 mM Tris-HCl, pH 7.5, 40 μM EDTA, and 55% ethanol. The washing reagent continues to flow through the flow controller 41A and into the waste site 139.

After washing the device 20, elution fluid from the storage
30 site 127 is forced to flow down channel 131 and through the device 20, thus releasing the nucleic acid from the internal surfaces of the extraction chamber into the elution fluid. At this point, the flow controllers 41A and 41B are

reconfigured to prevent the elution fluid from flowing through the flow controller **41A** and to permit the elution fluid to flow through the flow controller **41B** into the reagent site **141**. The flow rate of elution fluid through the device **20** is preferably in the range of 0.1 to 10 $\mu\text{L}/\text{sec}$. The flow rate of the elution fluid may be relatively slow as compared to the flow rate of the fluid sample to allow for more nucleic acid to be released from the chamber.

10

In general, any suitable elution fluid may be used to elute nucleic acid from the device **20**. Such elution fluids are well known in the art. For example, the elution fluid may comprise molecular grade pure water, or alternatively, a buffer solution, including but not limited to a solution of TRIS/EDTA; TRIS/acetate/EDTA, for example 4mM Tris-acetate (pH 7.8), 0.1 mM EDTA, and 50 mM NaCl; TRIS/borate; TRIS/borate/EDTA; potassium phosphate/DMSO/glycerol; NaCl/TRIS/EDTA; NaCl/TRIS/EDTA/TWEEN; TRIS/NaCl/TWEEN; phosphate buffers; TRIS buffers; HEPES buffers; nucleic acid amplification buffers; nucleic acid hybridization buffers, etc.

Prior to forcing the elution fluid to flow through the device **20**, an intermediate air-gap step may optionally be performed. A gas, preferably air, may be forced to flow through the device **20** after the wash solution flows through the device and before the elution fluid flows through the device. The air-gap step provides for clear separation of liquid phases, and helps at least substantially dry the chamber of any remaining wash solution prior to elution.

The extraction chamber of the device **20** is preferably heated as the elution fluid is forced to flow through the device to increase elution efficiency. The heating is preferably

35

performed by supplying power to the resistive heating element of the device 20 in a closed loop feedback system under the control of processing electronics 151, as previously described. In the preferred embodiment, the internal surfaces of the chamber are heated to a temperature in the range of 60 to 95 °C as the elution fluid flows through the chamber.

Elution fluid containing the nucleic acid exits the device 20 and travels down the channel 135 to the reagent site 141. The elution fluid and nucleic acid contact and reconstitute dried PCR reagents contained in the site 141, and the elution fluid, nucleic acid, and PCR reagents continue to flow into reaction site 143 for PCR amplification and detection. In an alternative embodiment, the elution solution already includes PCR reagents so that the reagent need not be dried in site 141. Vents 145 in communication with the waste site 139 and the reaction site 143 allow release of gases during the process.

One advantage of the flow-through device of the preferred embodiment is that it allows the nucleic acid from a relatively large volume of fluid sample, e.g. several milliliters or more, to be concentrated into a much smaller volume of elution fluid, e.g., 25 µL or less. In contrast to prior art microfluidic devices which limit fluid sample volumes to microliter quantity boluses, the device of the present invention permits extraordinary concentration factors by efficiently extracting nucleic acid from milliliter quantities of fluid sample and eluting the nucleic acid into microliter quantity eluates.

In particular, the ratio of the fluid sample volume forced to flow through the device to the volume capacity of the extraction chamber is preferably at least 2:1, and more

preferably at least 10:1. In the preferred embodiment, the extraction chamber has a volume capacity in the range of 0.1 to 25 μ L, and the volume of fluid sample forced to flow through the device is in the range of 0.5 to 500 mL, enabling concentration factors of 100 or greater. For example, the nucleic acid from 1 mL of fluid sample may be captured in the device and concentrated into 10 μ L or less of elution fluid. These parameters are exemplary of the preferred embodiment and are not intended to limit the scope of the invention. In alternative embodiments, the volume capacity of the extraction chamber and the volume of fluid sample processed may be varied to tailor the device to specific applications.

Another advantage of the microfluidic device of the preferred embodiment is that it allows for rapid and direct heating of the internal attachment surfaces of the chamber. The integral nature and high thermal conductivity of the chamber walls and column structures allow for rapid heat transfer from the heating element directly to the attachment surfaces without necessitating heating of the fluid in the chamber. This improvement in efficiency is significant in terms of the speed, precision, and accuracy of the heating, as well as in the reduction in power required for the heating. In particular, the rapid and direct heating of the internal surfaces to which the nucleic acid is bound greatly increases the degree and efficiency of the nucleic acid elution, and provides a significant improvement over prior art methods and devices.

A further advantage of the microfluidic device of the preferred embodiment is that it includes an array of integrally formed microstructures, preferably high aspect ratio columns, which provide for a high degree of efficiency and control in separating nucleic acid from a fluid sample. In addition to allowing direct and rapid heating of

attachment surfaces, the microstructures greatly increase the effective surface area of the chamber which may be used to capture and elute the nucleic acid. Moreover, the shape and arrangement of the microstructures, as compared to
5 beads, filters, or membranes, decreases the likelihood that any fluid sample or nucleic acid will become trapped in the device during fluid processing.

Further, with regularly spaced columns, the diffusion
10 distances between the columns are consistent and there is uniformity of fluid flow so that every nucleic acid is subjected to the same "micro-environment" as opposed to the random nature of beads and fibers. This uniformity allows for predictability of extraction parameters including the
15 time required for each processing step, flow rates, heating amounts, fluid volumes, etc. In addition, the increased efficiency obtained by using an array of internal microstructures and by rapidly and directly heating attachment surfaces allows for the efficient extraction and
20 elution of nucleic acids with relatively high fluid flow rates through the chamber. This decreases the overall time required for the extraction and elution.

Moreover, a simple variation of the device 20 may be used to
25 selectively extract nucleic acids from a solution or suspension. In essence, a thin silicon-glass based insulator with an underlying conductor serves as the separation device. The insulator thickness may be from about 1 to 1,000 nm. A DC voltage (0.1 to 100 V) is applied
30 to the conductor. Nucleic acids in the fluid sample are selectively attracted to the glass surface from which they may be subsequently eluted.

In one embodiment, the device includes an extraction chamber
35 having vertical columns fabricated from a single substrate so that they are electronically and physically uniform. The columns are coated with a thin layer of silicon dioxide.

The substrate has a bond pad patterned thereon for providing an ohmic contact to the substrate. The ohmic contact functions as a first electrode and the device further includes a second electrode, preferably a wire disposed in the chamber, for electrically contacting the fluid sample. The electrodes are used to charge the internal attachment surfaces of the chamber relative to the fluid sample with a voltage to attract and/or elute nucleic acid.

As the sample flows through the device, a voltage is applied between the electrodes to create a surface charge of controlled density uniformly covering the internal surfaces of the chamber. The composition of the buffer/carrier solutions may be modified to control the charge distributions on the surface of the columns, as well as the net charge of the target macromolecules. For example, the depth and density of the charge at the surface of the microstructures is markedly influenced by fluid pH and ionic strengths. Attachment of target moieties may be enhanced, for example, by using ampholines, zwitterions, and large bulk macromolecules codissolved with the target, or by pulsing the polarity of the applied voltage, such as in dielectrophoresis. The latter method may be used to separate weakly bound non-target compounds from more strongly bound target moieties during the flow of the specimen or wash solutions.

Alternatively, an AC voltage may be tuned to a frequency that facilitates the attraction and retention of DNA, but not other molecules, to the internal surfaces of the chamber. After the entire volume of fluid sample has passed through the device, various rinsing solutions may be introduced into the device to effect the removal of loosely bound, undesired material. Changes in pH, salt concentration, or the use of additives, such as detergents or chaotropes, may be used to enhance such removal.

For elution, a small volume of carrier solution is introduced into the device, the voltage polarity is reversed from positive (which holds the nucleic acid) to negative, and the nucleic acids are released from the internal surfaces and allowed to flow out of the device as a highly concentrated bolus. The efficiency of the release may be enhanced by using dielectrophoresis, in which an AC frequency is selected which drives the nucleic acids away from the internal surfaces.

10

The attachment to, or release of, biological analytes from the structures may also be enhanced by providing means to transmit ultrasonic energy to the device. The structures may be induced to oscillate to increase the frequency of contact between individual molecules and the columns in an extraction process or to cause shearing of the molecules from the structures during the release or elution step. Additionally, a piezoelectric ceramic disk may be bonded to an exterior surface of the device. Application of an AC voltage to the disk will induce flexing and hence flex the array of microstructures. At resonance, the movement of the structure is maximized. The integration of a miniature ultrasonic horn into the device may also achieve this goal.

25

In another embodiment, a separate set of reaction structures comprised of conducting materials may be included in the device. These can serve as electrodes to effect electrophoretic pulses to increase the probability of the macromolecules encountering the non-conducting, but charged, attachment surfaces. They can also be used to facilitate the removal of bound target molecules from the array of non-conducting structures or columns. The latter may be accomplished with or without the concomitant reversal of the voltage polarity of the non-conducting capacitance electrodes and with or without chemically mediated desorption.

30

35

In another aspect of the invention, ligand binding methods can be adapted for use with the structures of the device. Ligand binding entities, such as nucleic acids and proteins, may be attached actively or passively to the surface of the structures to form a specific analyte-capturing surface. 5 Ligand coupling chemistries, such as silane-based chemistries, may be used. Bifunctional linkers, with one functionality binding to the internal surface and the other to a target in the fluid sample may be employed. A sample 10 containing the test analyte may then be passed through the device, and analyte binds to the ligand covered surface. After subsequent washing with one or more wash solutions, the ligand-analyte complexes can be eluted. Alternatively, a secondary anti-analyte molecule conjugated to a reporter 15 molecule may be passed through the device, so that the conjugate is captured by the analyte. This complex may also be eluted.

The devices of the present invention are also useful for 20 combinatorial synthesis of biopolymers such as oligonucleotides and polypeptides. Combinatorial synthesis allows very large numbers of sequences to be synthesized in a device by transporting, concentrating, and reacting monomers, coupling and deblocking reagents, and catalysts at 25 separately addressable reaction/extraction microstructures. This use exploits the ability of the device to insulate selected microstructures from each other and from nearby reagents.

30 The microfluidic device 20 of the preferred embodiment may be fabricated using a variety of techniques, including photolithography and/or micromachining. Fabrication is preferably carried out on silicon or other suitable substrate materials such as glass, silicon dioxide, 35 plastics, or ceramics. A preferred method for fabricating the microfluidic device using deep reactive ion etching (DRIE) will now be described.

A 100 mm, n-type (100), 0.1 to 0.2 ohm-cm, double side polished silicon wafer is used as starting material for the base substrate **22**. The wafer thickness is preferably in the
5 range of 350 to 600 μm , depending on the desired structure. In one embodiment of making the device, an ohmic contact may be made by using phosphorous ion implantation into a region in the backside, preferably to a depth of 0.2 to 5 μm . Alternatively, a p-type silicon wafer may be used, and the
10 ohmic contact made using boron ion implantation. Implantation is followed by heating of the substrate to activate the dopant.

The wafer is then spun with photoresist (commercially
15 available from, e.g., Shipley) on the frontside to obtain a photoresist thickness sufficient to mask the DRIE process. This thickness depends upon the final desired depth of the etch. The ratio of silicon etch rate to photoresist erosion rate is typically greater than 50:1. To etch structures
20 that are 200 μm deep, 4 μm of photoresist is usually sufficient. The photoresist is softbaked at 90 °C for about 30 minutes, then exposed with the desired mask pattern, developed, and hardbaked using processes well known in the art of silicon wafer processing.

25
FIG. 11 illustrates a sample mask pattern on the frontside of the wafer. The etch mask defines a chamber pattern **44** for forming the extraction chamber in the substrate **22** and an array of column patterns **46** for forming a corresponding
30 array of columns in the substrate. Due to space limitations in drawing size, the etch mask is illustrated with only several hundred column patterns **46**. In the preferred embodiment, however, the array includes 1,000 to 10,000 column patterns for forming a corresponding number of
35 columns in the substrate **22**.

The patterned wafer is then etched using a DRIE process to form the extraction chamber and integral columns. A device useful for etching is commercially available from Surface
5 Technology Systems of Redwood City, California. The DRIE process involves the use of inductively coupled plasma etching and deposition in an alternating fashion, using fluorine based chemistry. Aspect ratios of 20:1 in etched structures are easily realized. The etch rate is typically
10 2 $\mu\text{m}/\text{min}$ or higher.

After etching, the remaining photoresist is removed from the wafer, e.g., by oxygen plasma etching or wet chemical stripping in sulfuric acid. The substrate is then oxidized
15 to cover the internal surfaces of the chamber, i.e., the chamber walls and surfaces of the columns, with an oxide layer. The oxide layer is preferably 1 to 100 nm thick, and may be formed using any well known technique, e.g., thermal growth, chemical or electrochemical growth, or deposition.

20 An electrically conductive material, e.g., aluminum, gold, or copper, is then deposited and patterned on the backside of the substrate to form the resistive heating element, temperature sensor, and bond pads. Different materials may
25 be used to form the heating element and sensor. Specific techniques for patterning metal on a substrate are well known in the art. The substrate is then anodically bonded to a thin, e.g., 500 μm , pyrexTM glass cover. The glass cover has holes fabricated in it, e.g., by ultrasonic
30 milling, which form the fluid ports to the chamber. After bonding, the substrate pair may be diced using a diamond saw. The resulting structure is shown schematically in FIG. 6.

35 The exact dimensions and structure of the microfluidic device may be varied to suit the device to a particular

application. A specific example of one possible device according to the present invention is as follows. The device is 4.0 mm square and 0.9 mm thick. The extraction chamber has a depth of 200 μm and a length and width of 2.8 mm. The fluid ports each have a width of 0.4 mm. The device has a dense array of columns occupying an area 2.0 mm x 2.8 mm within the chamber. The columns have a height of 200 μm , a cross sectional length of 50 μm , a cross sectional width of 7 μm , a gap distance of 8 μm between adjacent columns in a row, and a center to center spacing of 15 μm . There are roughly 7,000 columns in the array. Of course, these dimensions are exemplary of just one possible embodiment and are not intended to limit the scope of the invention. The specific dimensions of each material of the device may be varied in alternative embodiments, preferably within the general guidelines set forth earlier in this description.

Specific techniques for fabricating a cartridge suitable for use with the microfluidic device of the present invention are disclosed in U.S. application Ser. No. 08/998,188 filed December 24, 1997. For example, the cartridge may be made from at least one injection molded, press molded, or machined polymeric part that has wells, recesses, or depressions manufactured into its surface to define several walls of the channels, reaction sites, and storage sites. Examples of suitable polymers for injection molding or machining include, e.g., polycarbonate, polystyrene, polypropylene, polyethylene, acrylic, and commercial polymers. A second part that is complementary in shape to the first part is mated to the surface of the first part to define the remaining wall of the cartridge. The second part or a third part may be a printed circuit board for implementing electrical contacts in the cartridge.

These techniques may be employed to incorporate the microfluidic device into one of the recesses in the cartridge. The device may be attached to the cartridge using a flexible, polymeric coating, such as a silicone glue. Alternatively, a gasket may be fabricated with matching holes to the fluidic ports of the device and a sealed fluidic assembly made between the microfluidic device and the cartridge body. The device may be pressed tightly and sealed against the gasket material by bonding another plastic piece over the device, thus completely encapsulating the device within the cartridge.

Alternatively, the device may be fused or welded to the cartridge directly without the use of a gasket. In a particularly advantageous embodiment, a portion of the cartridge itself may be the cover for the device rather than using a separate substrate, e.g., the pyrex™ glass, to form the cover. In this embodiment, the substrate 22 is inserted into the cartridge and sealed to a wall of the cartridge. The wall has holes in it forming the fluid ports to the extraction chamber.

FIG. 13 shows an alternative embodiment of the invention in which the microfluidic device has fluid ports 28 and 30 formed in the base substrate 22 rather than the top substrate 24. The device also includes electrodes 48A and 48B for heating the internal surfaces of the chamber 26. The electrodes are preferably positioned on opposite sides of the bottom wall 23 of the extraction chamber 26. The base substrate 22 is fabricated from a thermally conductive material, preferably silicon, so that the bottom wall 23 and integrally formed columns may be heated by applying an appropriate voltage across the electrodes 48A and 48B.

As in the preferred embodiment, the device is preferably used in combination with a cartridge having a pre-processing site for the fluid sample and/or a post-processing site for the eluted nucleic acid. The cartridge may also include appropriate processing electronics for supplying power to the electrodes 48A and 48B. The operation of the device is analogous to the operation described in the preferred embodiment above, except that the internal surfaces of the chamber 26 are heated by applying a voltage across the electrodes 48A and 48B. The bottom wall 23 functions as a resistive heating element for heating the chamber 26.

The microfluidic device of FIG. 13 may be fabricated using a variety of techniques, including photolithography and/or micromachining. A preferred method for fabricating the device will now be described.

A 100 mm, n-type (100), silicon wafer is used as starting material for the base substrate 22. The wafer preferably has a resistivity of 1 to 100 ohm-cm, depending on the desired final resistance between the electrodes 48A and 48B. The wafer thickness is preferably in the range of 350 to 600 μm , depending on the desired structure. Ohmic contacts are made by using phosphorous ion implantation into regions in the backside, preferably to a depth of 0.2 to 5 μm . Alternatively, a p-type silicon wafer may be used, and the ohmic contacts made using boron ion implantation. Implantation is followed by heating of the substrate to activate the dopant.

Next, the fluid ports 28 and 30 are formed by depositing and patterning a suitable masking material, e.g., silicon nitride, onto the backside of the wafer and anisotropic etching the silicon using the mask. The wafer is then patterned with photoresist on the frontside to obtain an

etch mask for the DRIE process. As shown in FIG. 13, the etch mask defines a chamber pattern 44 for forming the extraction chamber in the substrate 22 and an array of column patterns 46 for forming a corresponding array of columns in the substrate. The patterned wafer is then etched using a DRIE process to form the extraction chamber and integral columns. The wafer is etched to a depth sufficient for the extraction chamber 26 to meet the fluid ports 28 and 30.

10

After etching, the remaining photoresist is removed from the wafer, and the substrate is then oxidized to cover the internal surfaces of the chamber 26 with an oxide layer, preferably 1 to 100 nm thick. An electrically conductive material, e.g., aluminum, gold, or copper, is then deposited and patterned over the doped regions on the backside of the substrate to form the electrodes 48A and 48B. The substrate 22 is then anodically bonded to a cover 24, preferably thin pyrex™ glass. After bonding, the substrate pair may be diced to form the final structure shown in FIG. 13.

20

FIG. 14 shows a flow-through device 21 according to another embodiment of the invention in which the internal attachment surfaces for capturing and eluting the nucleic acid are formed by one or more solid supports contained within the chamber 26. As the fluid sample flows through the chamber 26, the nucleic acid contacts and adheres to the solid support. To elute the nucleic acid, the chamber 26 is heated while an elution fluid is forced to flow through the chamber, thus releasing the nucleic acid from the solid support into the elution fluid. Suitable solid supports for capturing the nucleic acid include beads, fibers, membranes, glass wool, filter paper, gels, etc. comprising material

30

having a binding affinity with the nucleic acid, e.g., silica, diethylaminoethyl (DEAE), and polymers.

In the embodiment of FIG. 14, the solid support comprises glass beads 50 packed within the chamber 26. In embodiments that employ beads, fibers, wool, or gels as the solid support, the device preferably includes a barrier 52 disposed in the chamber 26 adjacent the outlet port 30 for preventing the solid support material from flowing out of the chamber. The barrier 52 may be any suitable retaining membrane or filter, such as a comb filter, for holding the solid support material within the chamber 26.

Alternatively, the barrier 52 may comprise a plurality of internal structures, such as columns, formed within the chamber 26 and having a sufficiently small spacing to retain the solid support material. FIG. 1D shows a row of columns forming a filter suitable for retaining beads in a chamber.

As in the preferred embodiment, the device 21 is preferably used in combination with a cartridge having a pre-processing site for the fluid sample and/or a post-processing site for the eluted nucleic acid. The cartridge may also include appropriate processing electronics for supplying power to the resistive heating element 34. The operation of the device 21 is analogous to the operation described in the preferred embodiment above, except that the internal attachment surfaces in the chamber 26 are provided by a solid support, such as the beads 50, rather than by an array of integrally formed microstructures.

The device 21 may be fabricated using techniques similar to those described in earlier embodiments, including photolithography and micromachining. A preferred method for fabricating the device will now be described. A 100 mm, n-

type (100), 0.1 to 0.2 ohm-cm, silicon wafer is preferably used as starting material for the base substrate 22. The wafer is patterned with photoresist on the frontside to obtain an etch mask for a DRIE process. The etch mask defines a chamber pattern for forming the chamber 26 in the substrate 22 and a barrier pattern for forming internal barrier structures, preferably closely spaced columns, within the chamber 26. The patterned wafer is then etched using a DRIE process to form the chamber 26 and internal barrier structures. Of course, the structures should have a spacing smaller than the diameter of the beads 50 so that they will retain the beads in the chamber 26.

After etching, the remaining photoresist is removed from the wafer, and one or more electrically conductive materials is then deposited and patterned on the backside of the substrate to form a resistive heating element, temperature sensor, and bond pads. The substrate is then anodically bonded to a glass cover having holes that form the fluid ports 28 and 30. The beads 50 may be packed in the chamber 26 before or after attaching the cover, preferably after the cover is attached. The beads 50 are inserted through the inlet port 28. Of course, the barrier 52 should be in place before packing the beads 50 to prevent the beads from flowing out of the chamber 26.

FIG. 15 shows a flow-through device 31 according to another embodiment of the invention in which the solid support contained within the chamber 26 comprises a membrane or filter 60 for capturing the nucleic acid. The device 31 includes a base substrate 58, a top substrate 54, and a middle substrate 56 sandwiched between the top and base substrates. The extraction chamber 26 is formed in the top

and base substrates 54 and 58, and the filter 60 is preferably in thermal contact with the heater 34. Alternatively, the filter 60 may be disposed in the base substrate 58 adjacent the outlet port 30.

5

The resistive heating element 34 is preferably positioned on the middle substrate 56 for heating the chamber 26. The heating element 34 may be covered by a layer 62 of insulating material, e.g., silicon dioxide, silicon carbide, silicon nitride, plastic, glass, glue or other polymers, resist, or ceramic, for protecting the heating element 34 from fluids flowing through the chamber 26. The middle substrate 56 includes holes (not shown in the cross sectional view of FIG. 15) disposed around the heating element 34 to permit continuous fluid flow through the chamber from the inlet port 28 to the outlet port 30.

The heating element 34 may be a thin film of metal or polysilicon which is patterned on the substrate 56. Alternatively, the substrate 56 may be a thin plastic flex-circuit having the heating element 34. In another embodiment, the heating element 34 may comprise a laminated heater source, such as an etched foil-heating element, attached to the substrate 56. In embodiments where the heater is part of a laminated structure, the substrate 56 is the support for the heater. In yet another embodiment, the substrates 56 and 58, together with the heating element 34 and insulator layer 62, may all be fabricated from a single substrate using techniques known to those skilled in the art, e.g., thin film processing.

The device 31 is preferably used in combination with a cartridge having a pre-processing site for the fluid sample and/or a post-processing site for the eluted nucleic acid. The cartridge may also include appropriate processing
5 electronics for supplying power to the heating element 34. In operation, the fluid sample is forced to flow through the device. As the fluid sample flows through the chamber 26, the nucleic acid contacts and adheres to the filter 60. The chamber is optionally washed to remove unwanted particles.
10 To elute the nucleic acid, the chamber 26 is heated with the heating element 34 while an elution fluid is forced to flow through the chamber, releasing the nucleic acid from the filter 60 into the elution fluid.

15 The top and base substrates 54 and 58 are preferably low cost molded plastic parts, and the middle substrate 56 is preferably a plastic flex circuit. The device 31 may be fabricated by precutting the filter 60 to size and then assembling the filter 60 and the substrates 54, 56, and 58
20 using adhesives, such as glue, or by welding, e.g. ultrasonic welding.

SUMMARY, RAMIFICATIONS, AND SCOPE

Although the above description contains many specificities,
25 these should not be construed as limitations on the scope of the invention, but merely as illustrations of some of the presently preferred embodiments. Many other embodiments of the invention are possible. For example, in one alternative
30 embodiment, the internal attachment surfaces of the chamber are charged with AC or DC voltages to attract and/or elute the nucleic acid. The present invention enables combining more than one elution technique, including chemical, heat, and electrophoresis, to reduce the elution volume needed to fully elute the nucleic acids. In another embodiment, the

nucleic acid is treated after it is bound to the attachment surfaces. For example, secondary binding members with reporter molecules may be passed through the extraction chamber to bind to the already bound nucleic acid. This complex may then be eluted. In addition, the chamber may be functionalized with specific capture moieties which bind specific targets such as cells, bacteria, viruses or specific nucleic acids.

10 It is presently preferred to heat the chamber using a resistor coupled to a chamber wall to permit direct and rapid heating of the attachment surfaces. The scope of the invention is not limited to this embodiment, however. Many different mechanisms and methods for heating the chamber will be apparent to one skilled in the art, including optical heating, ultrasonic heating, inductively coupled coils, microwaves, or any other suitable mechanism for heating the chamber. Further, when the device is used in combination with a cartridge, the cartridge or an instrument used for processing the cartridge may contain a heater for heating the device.

Although it is presently preferred to use the flow-through device of the present invention in combination with a cartridge, the scope of the invention is not limited to this embodiment. It will be apparent to one skilled in the art upon consideration of the above description that the device may be interfaced to any chemical analysis system, or alternatively, be used as a stand-alone device for extracting a desired material from a fluid sample. Moreover, although the extraction of nucleic acid is presented as an exemplary embodiment of the invention, it will be apparent to one skilled in the art that the devices of the present invention may be used to separate many other desired materials from a fluid sample, such as organisms, cells, proteins, carbohydrates, virus particles, bacteria, chemicals, and biochemicals.

Therefore, the scope of the invention should be determined by the following claims and their legal equivalents.

1
2
3
4
5
6
7
8
9
10
11
12
13
14
15
16
17
18
19
20
21
22
CLAIMS

What is claimed is:

1. A flow-through device for separating a desired material from other materials in a fluid sample, the device comprising a body having formed therein:

- a) an inlet port for introducing the fluid sample into the body;
- b) an outlet port for exit of the fluid sample from the body; and
- c) an extraction chamber in fluid communication with the inlet and outlet ports for extracting the desired material from the fluid sample as the sample flows through the body, wherein the inlet and outlet ports are positioned to permit continuous fluid flow through the extraction chamber, the chamber is formed by internal surfaces of the body, and at least one of the internal surfaces has sufficiently high surface area and binding affinity with the desired material to capture the material as the fluid sample flows through the chamber.

2. The device of claim 1, wherein the internal surfaces comprise surfaces of internal microstructures integrally formed with at least one wall of the extraction chamber and extending into the chamber.

3. The device of claim 2, wherein the microstructures comprise an array of high aspect ratio columns.

4. The device of claim 2, wherein the microstructures are disposed in rows, and wherein the rows are arranged such that the microstructures in each row are misaligned with the microstructures in adjacent rows.

- 1 5. The device of claim 4, wherein the rows are arranged such
2 that the microstructures in each row are misaligned with the
3 microstructures in at least two previous or successive rows.
4
- 1 6. The device of claim 2, wherein each of the microstructures
2 has a ratio of cross-sectional length to width of at least
3 4:1.
4
- 1 7. The device of claim 1, wherein the desired material is
2 selected from the group consisting of organisms, cells,
3 proteins, nucleic acids, carbohydrates, virus particles,
4 bacteria, chemicals, and biochemicals.
5
- 1 8. The device of claim 1, wherein at least one of the internal
2 surfaces is coated with a substance having a binding
3 affinity with the desired material to facilitate capture of
4 the material.
5
- 1 9. The device of claim 8, wherein the substance is selected
2 from the group consisting of silicon, silicon dioxide,
3 polymers, polyamides, nucleic acids, metals, polypeptides,
4 proteins, and polysaccharides.
5
- 1 10. The device of claim 1, further comprising a heater for
2 heating the extraction chamber.
3
- 1 11. The device of claim 10, wherein the heater comprises a
2 resistive heating element coupled to at least one wall of
3 the chamber.
4
- 1 12. The device of claim 10, wherein the heater comprises
2 electrodes for applying a voltage difference across at least
3 one portion of the body forming the chamber.
4

- 1 13. The device of claim 10, further comprising processing
2 electronics for controlling the operation of the heater.
3
- 1 14. The device of claim 1, wherein the device is in combination
2 with a cartridge having a pre-processing site for the fluid
3 sample, and wherein the device is constructed to be inserted
4 into the cartridge such that the inlet port is in fluid
5 communication with the pre-processing site.
6
- 1 15. The device of claim 1, wherein the device is in combination
2 with a cartridge having a post-processing site for eluted
3 material, and wherein the device is constructed to be
4 inserted into the cartridge such that the outlet port is in
5 fluid communication with the post-processing site.
6
- 1 16. A method for separating a desired material from other
2 materials in a fluid sample, the method comprising the steps
3 of:
4 a) providing a flow-through device comprising a body
5 having an inlet port, an outlet port, and an extraction
6 chamber in fluid communication with the inlet and outlet
7 ports, wherein the extraction chamber is formed by
8 internal surfaces of the body, and wherein the internal
9 surfaces have sufficiently high surface area and binding
10 affinity with the desired material to capture the
11 material as the fluid sample flows through the chamber;
12 b) forcing the fluid sample to flow continuously through
13 the chamber, thereby binding the desired material to the
14 internal surfaces as the fluid sample flows through the
15 chamber; and
16 c) eluting the desired material from the device by
17 forcing an elution fluid to flow through the chamber,
18 thereby releasing the material from the internal surfaces
19 into the elution fluid.
20

- 1 17. The method of claim 16, wherein the desired material is
2 selected from the group consisting of organisms, cells,
3 proteins, nucleic acids, carbohydrates, virus particles,
4 bacteria, chemicals, and biochemicals.
5
- 1 18. The method of claim 16, wherein the volume of fluid sample
2 forced to flow through the chamber is greater than the
3 volume capacity of the chamber.
4
- 1 19. The method of claim 16, wherein the step of eluting the
2 material further comprises heating the internal surfaces
3 while forcing the elution fluid to flow through the chamber.
4
- 1 20. The method of claim 16, further comprising the step of
2 forcing a gas to flow through the chamber prior to the step
3 of forcing the elution fluid to flow through the chamber.
4
- 1 21. The method of claim 16, further comprising the step of
2 contacting the fluid sample with a lysing reagent as the
3 sample flows through the chamber.
4
- 1 22. The method of claim 16, wherein the internal surfaces
2 comprise surfaces of internal microstructures integrally
3 formed with at least one wall of the extraction chamber, and
4 wherein the desired material is bound to the surfaces of the
5 microstructures.
6
- 1 23. The method of claim 22, wherein the microstructures comprise
2 columns extending into the chamber, and wherein the step of
3 forcing the fluid sample to flow through the chamber
4 comprises forcing the fluid sample to flow between the
5 columns.
6
- 1 24. The method of claim 16, further comprising the step of
2 applying a voltage difference between the body and the fluid

3 sample while forcing the sample to flow through the chamber
4 to facilitate capture of the desired material.
5

1 25. A flow-through device for separating a desired material from
2 other materials in a fluid sample, the device comprising:

3 a) a microfabricated chip having formed therein:

4 i) an inlet port for introducing the fluid sample into
5 the chip;

6 ii) an outlet port for exit of the fluid sample from the
7 chip; and

8 iii) an extraction chamber for extracting the desired
9 material from the fluid sample as the sample flows
10 through the chip, wherein the extraction chamber is
11 in fluid communication with the inlet and outlet
12 ports, and wherein the inlet and outlet ports are
13 positioned to permit continuous fluid flow through
14 the chamber;

15 b) a heater for heating the extraction chamber; and

16 c) at least one solid support contained within the
17 extraction chamber for capturing the desired material as
18 the fluid sample flows continuously through the chamber.
19

1 26. The device of claim 25, wherein the solid support comprises
2 a support selected from the group consisting of beads,
3 fibers, membranes, glass wool, filter paper, and gels.
4

1 27. The device of claim 25, wherein the desired material is
2 selected from the group consisting of organisms, cells,
3 proteins, nucleic acids, carbohydrates, virus particles,
4 bacteria, chemicals, and biochemicals.
5

1 28. The device of claim 25, wherein the heater comprises a
2 resistive heating element coupled to at least one wall of
3 the chamber.
4

1 29. The device of claim 25, wherein the heater comprises
2 electrodes for applying a voltage difference across at least
3 one portion of the chip forming the chamber.
4

1 30. The device of claim 25, further comprising processing
2 electronics for controlling the operation of the heater.
3

1 31. The device of claim 25, wherein the device is in combination
2 with a cartridge having a pre-processing site for the fluid
3 sample, and wherein the device is constructed to be inserted
4 into the cartridge such that the inlet port is in fluid
5 communication with the pre-processing site.
6

1 32. The device of claim 25, wherein the device is in combination
2 with a cartridge having a post-processing site for eluted
3 material, and wherein the device is constructed to be
4 inserted into the cartridge such that the outlet port is in
5 fluid communication with the post-processing site.
6

1 33. A method for separating a desired material from other
2 materials in a fluid sample, the method comprising the steps
3 of:

4 a) providing a chip having formed therein an inlet port, an
5 outlet port, and an extraction chamber in fluid
6 communication with the inlet and outlet ports for
7 extracting the desired material from the fluid sample,
8 wherein the inlet and outlet ports are positioned to
9 permit continuous fluid flow through the chamber, and
10 wherein the chamber contains at least one solid support
11 for capturing the desired material as the fluid sample
12 flows through the chamber;

13 b) forcing the fluid sample to flow continuously through the
14 extraction chamber, thereby binding the desired material
15 to the solid support as the sample flows through the
16 chamber; and

17 c) eluting the desired material from the chip by heating the
18 chamber and forcing an elution fluid to flow through the
19 chamber, thereby releasing the material from the solid
20 support into the elution fluid.
21

1 34. The method of claim 33, wherein the desired material is
2 selected from the group consisting of organisms, cells,
3 proteins, nucleic acids, carbohydrates, virus particles,
4 bacteria, chemicals, and biochemicals.
5

1 35. The method of claim 33, wherein the volume of fluid sample
2 forced to flow through the chamber is greater than the
3 volume capacity of the chamber.
4

1 36. The method of claim 33, further comprising the step of
2 forcing a gas to flow through the extraction chamber prior
3 to the step of forcing the elution fluid to flow through the
4 chamber.
5

1 37. The method of claim 33, further comprising the step of
2 contacting the fluid sample with a lysing reagent as the
3 fluid sample flows through the chamber.
4

1 38. A device for manipulating fluids, the device comprising a
2 substrate having formed therein at least first and second
3 channels for carrying first and second fluid streams,
4 respectively, wherein the first and second channels merge
5 into a common channel to provide a contact region for the
6 fluid streams, and wherein the common channel has an
7 internal surface area greater than three times its facial
8 surface area to provide a large interfacial area between the
9 fluid streams.
10

1 39. The device of claim 38, further comprising pillars disposed
2 in the common channel to increase the stability of the fluid
3 streams.

4
1 40. The device of claim 38, wherein the first and second
2 channels merge into a plurality of common channels to
3 provide a corresponding plurality of contact regions for the
4 fluid streams.

5
1 41. The device of claim 38, further comprising third and fourth
2 channels in fluid communication with the common channel for
3 carrying the first and second fluid streams, respectively,
4 away from the contact region.

5
1 42. A device for manipulating fluids, the device comprising a
2 substrate having formed therein:
3 a) a first channel for carrying a first fluid stream; and
4 b) second and third channels in fluid communication with and
5 diverging from the first channel for separating the first
6 fluid stream into second and third fluid streams,
7 respectively, wherein each of the channels has an
8 internal surface area greater than three times its facial
9 surface area.

10

1/15

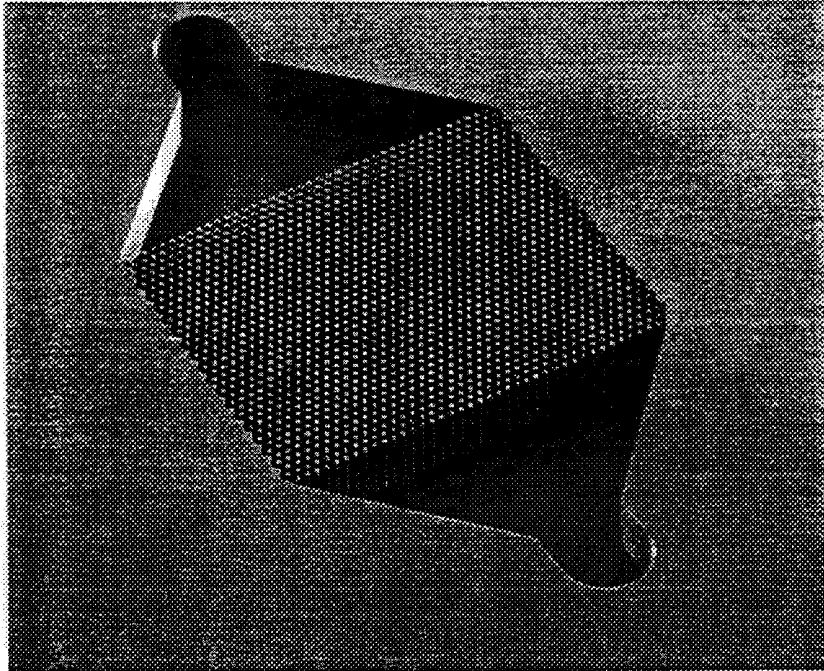

FIG. 1A

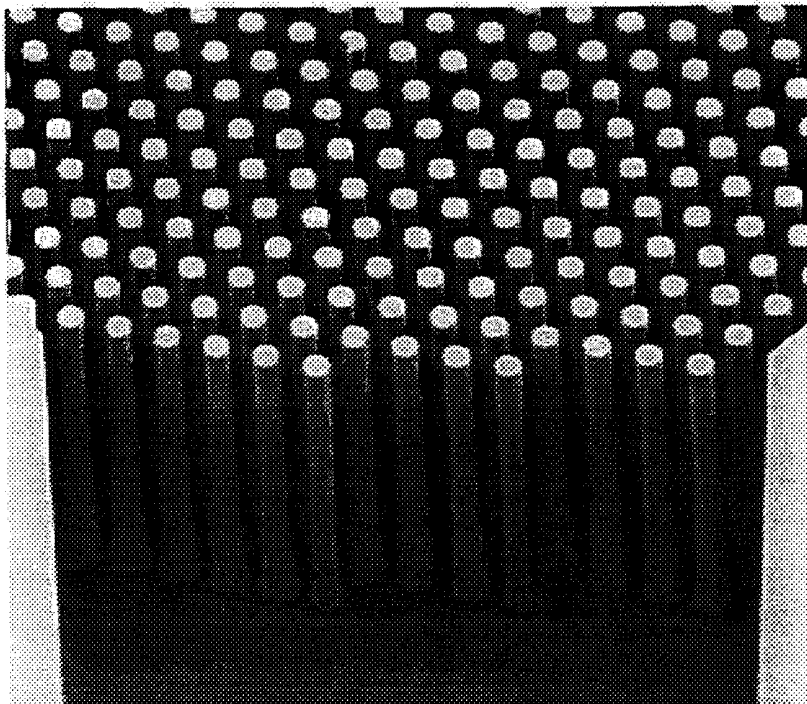

FIG. 1B

2/15

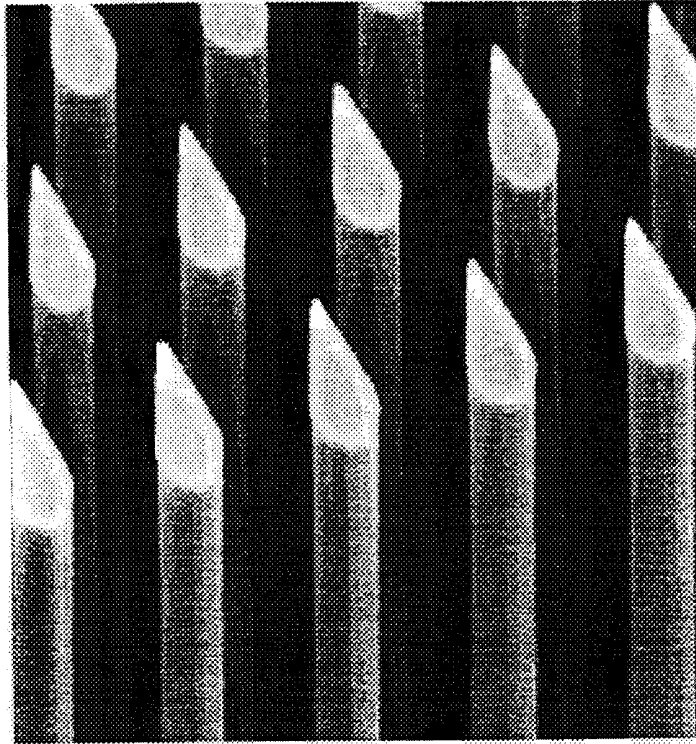

FIG. 1C

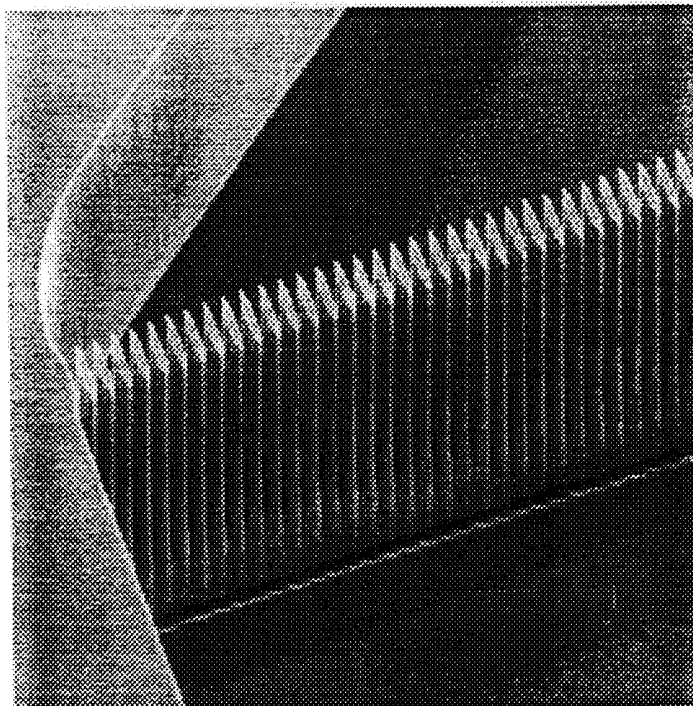

FIG. 1D

3/15

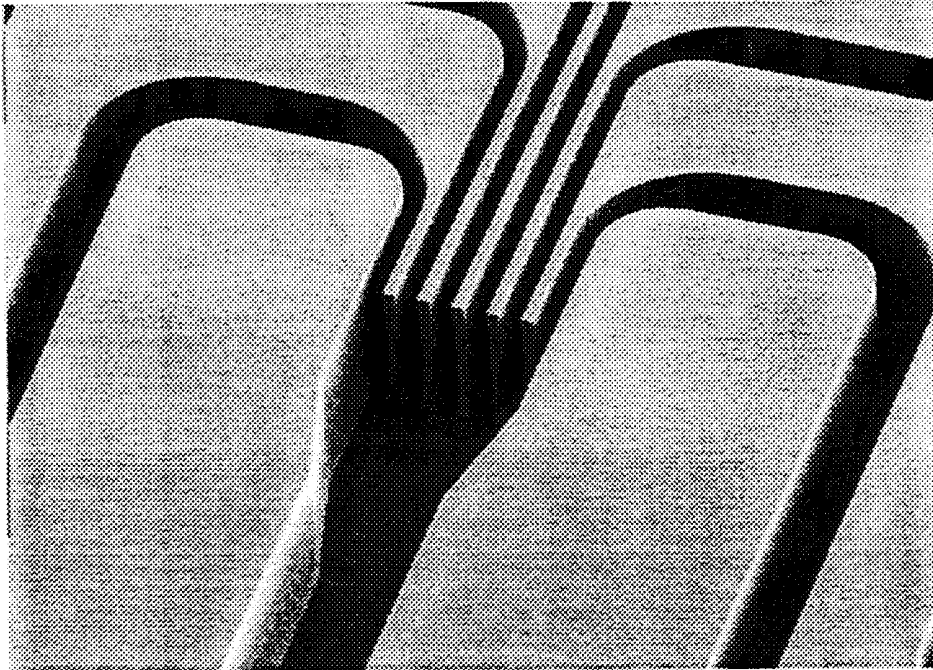

FIG. 1E

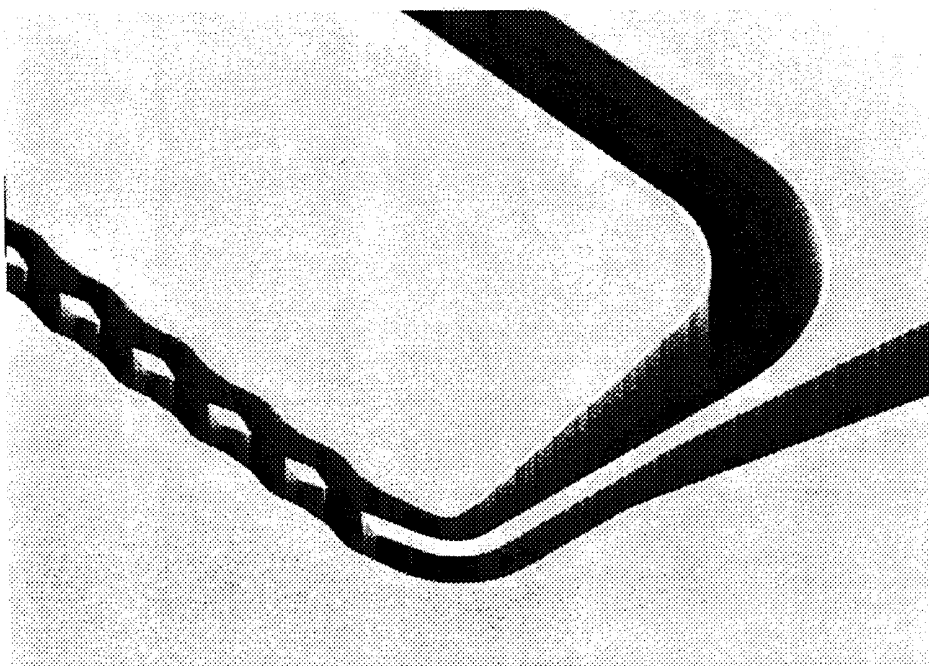

FIG. 1F

4/15

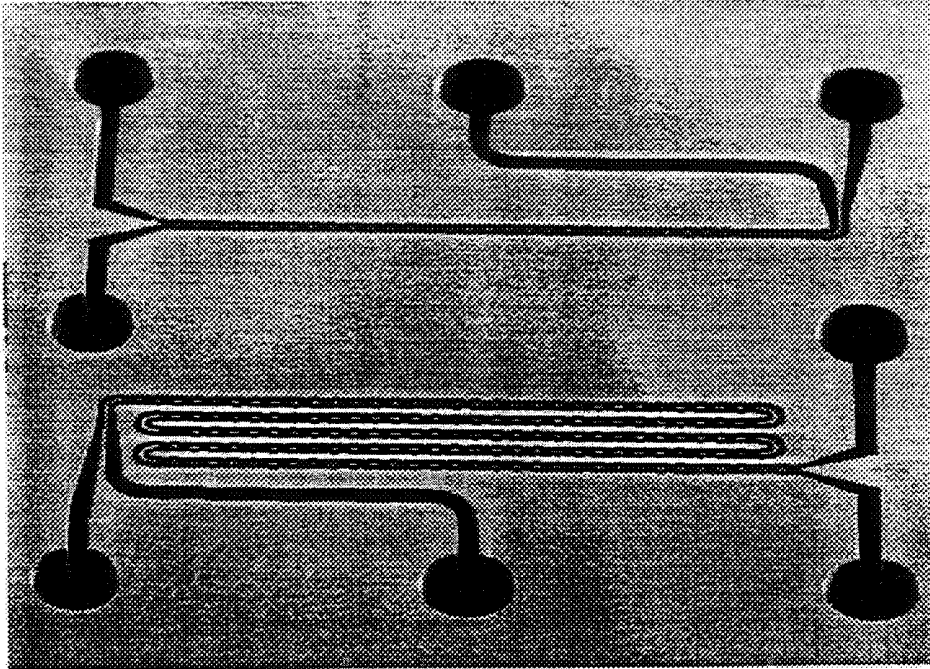

FIG. 1G

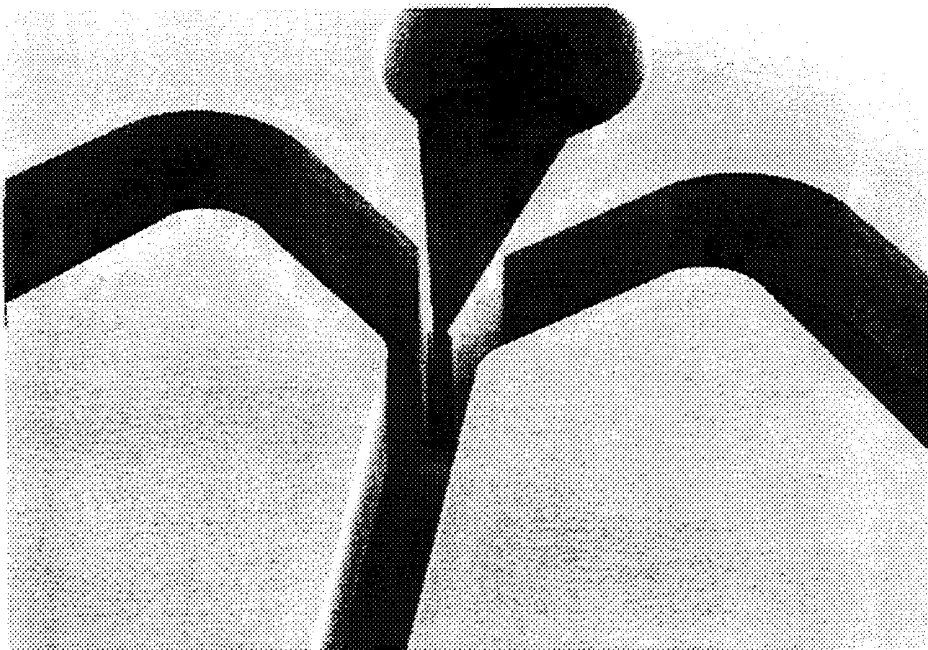

FIG. 1H

5/15

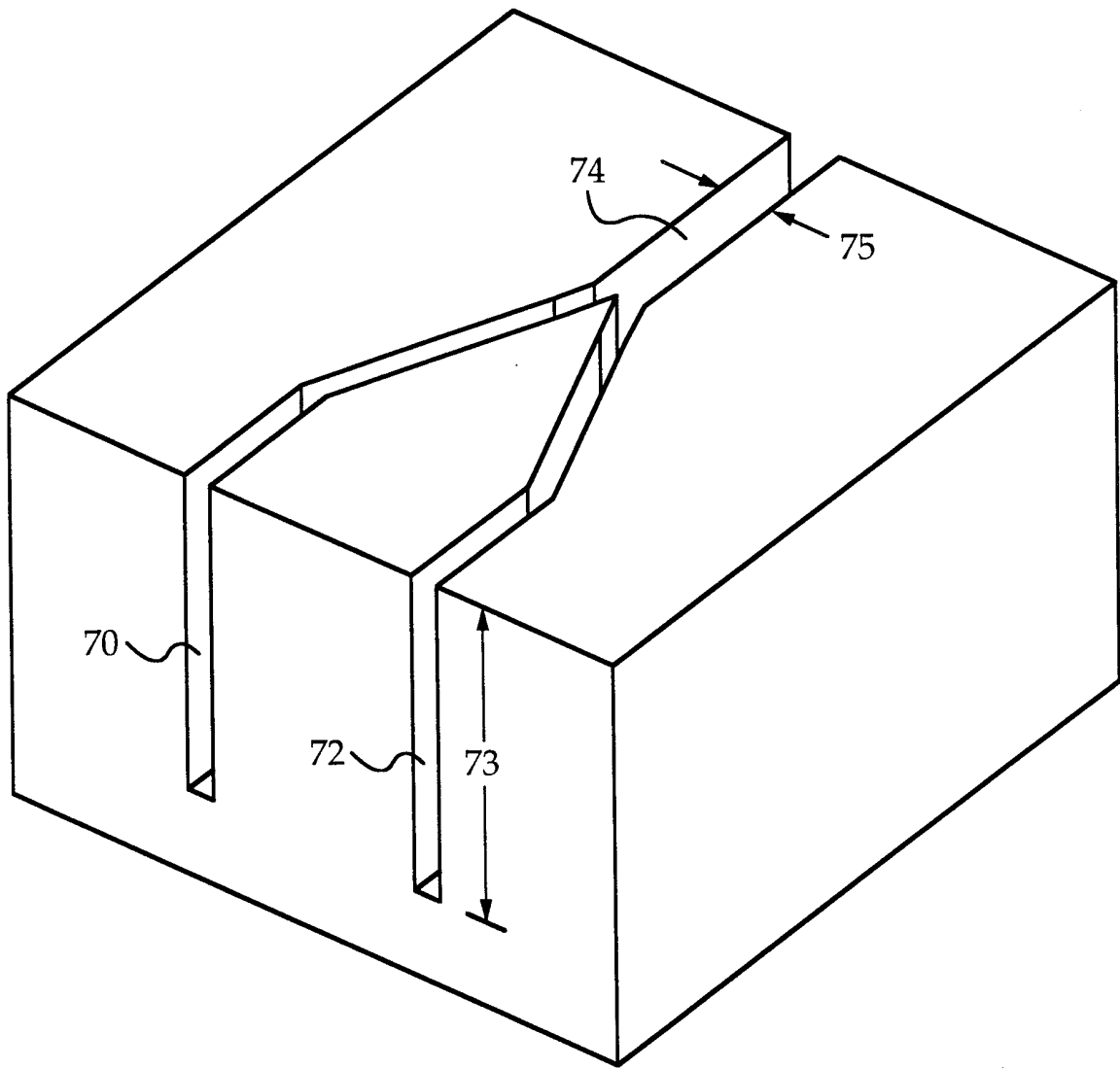

FIG. 2

6/15

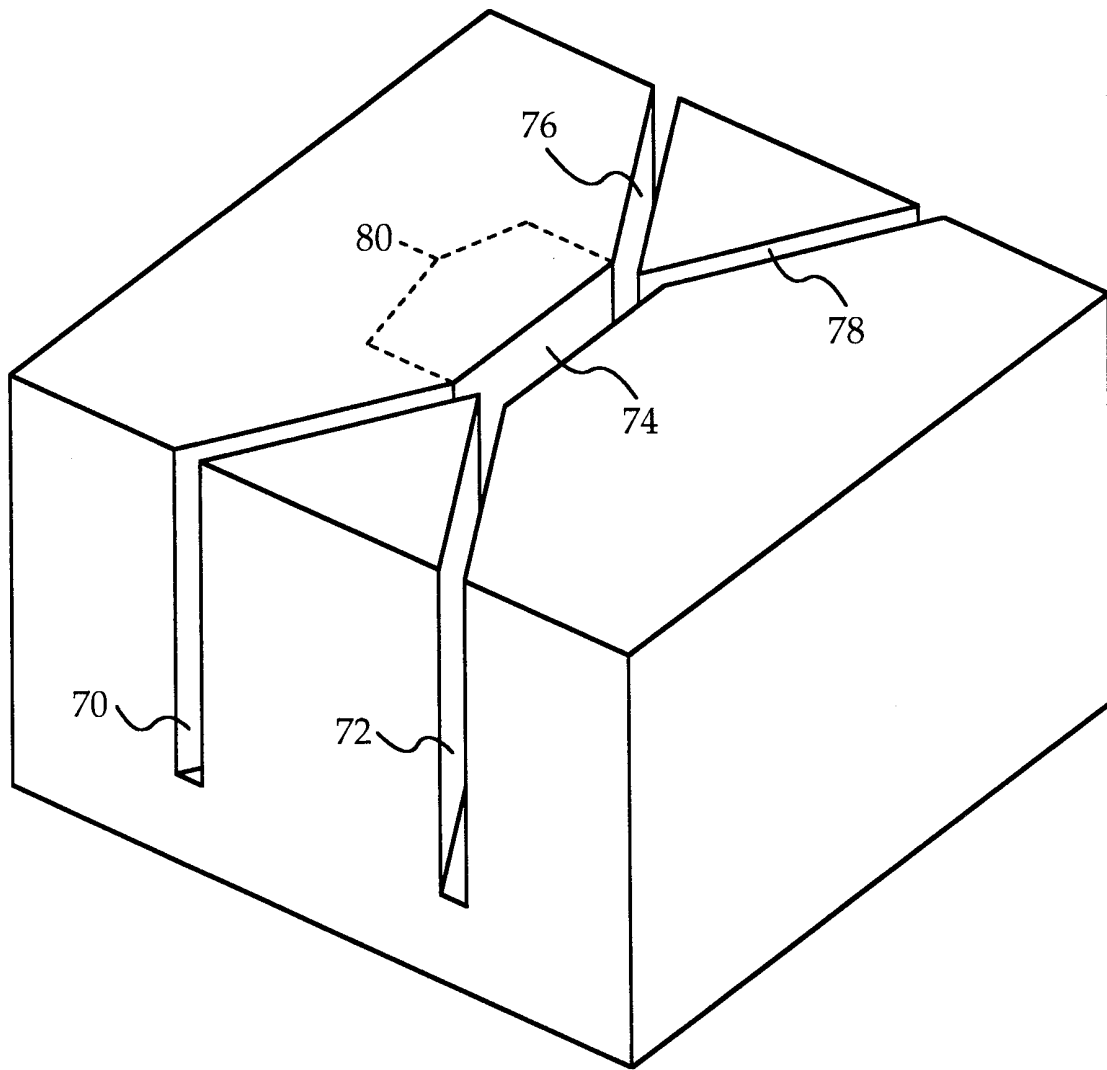

FIG. 3

7/15

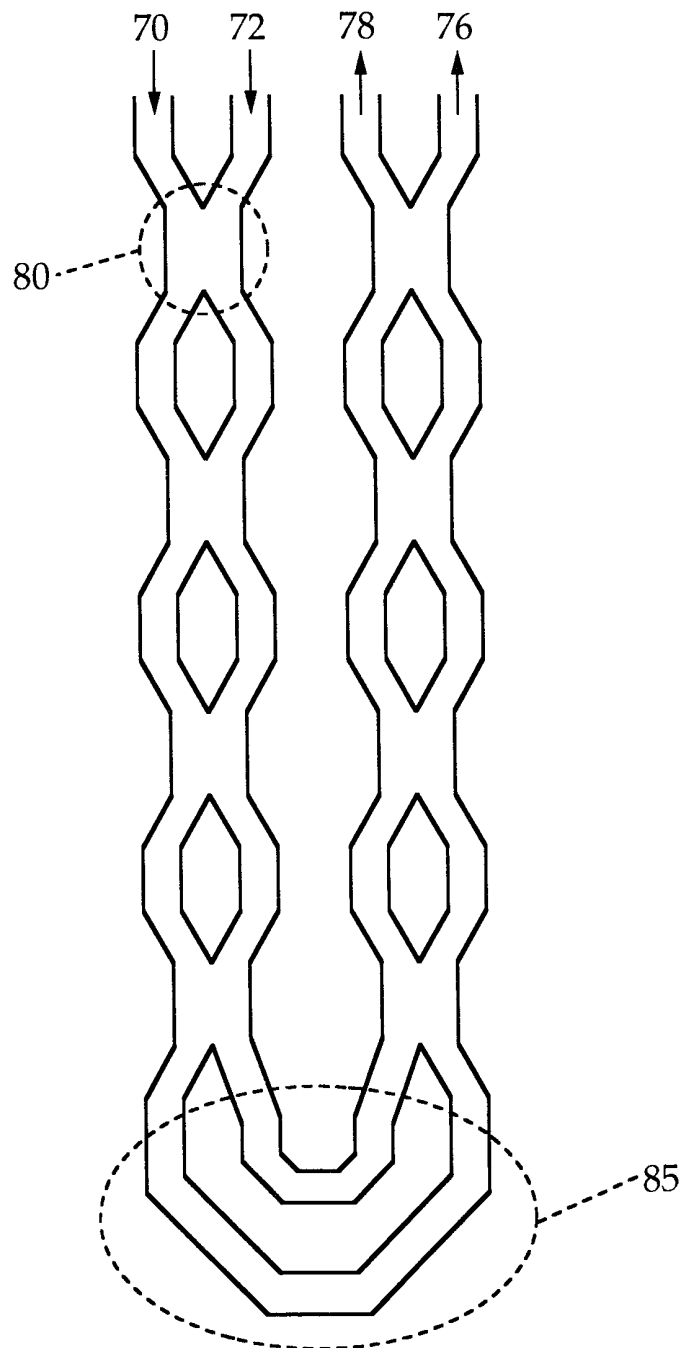

FIG. 4

8/15

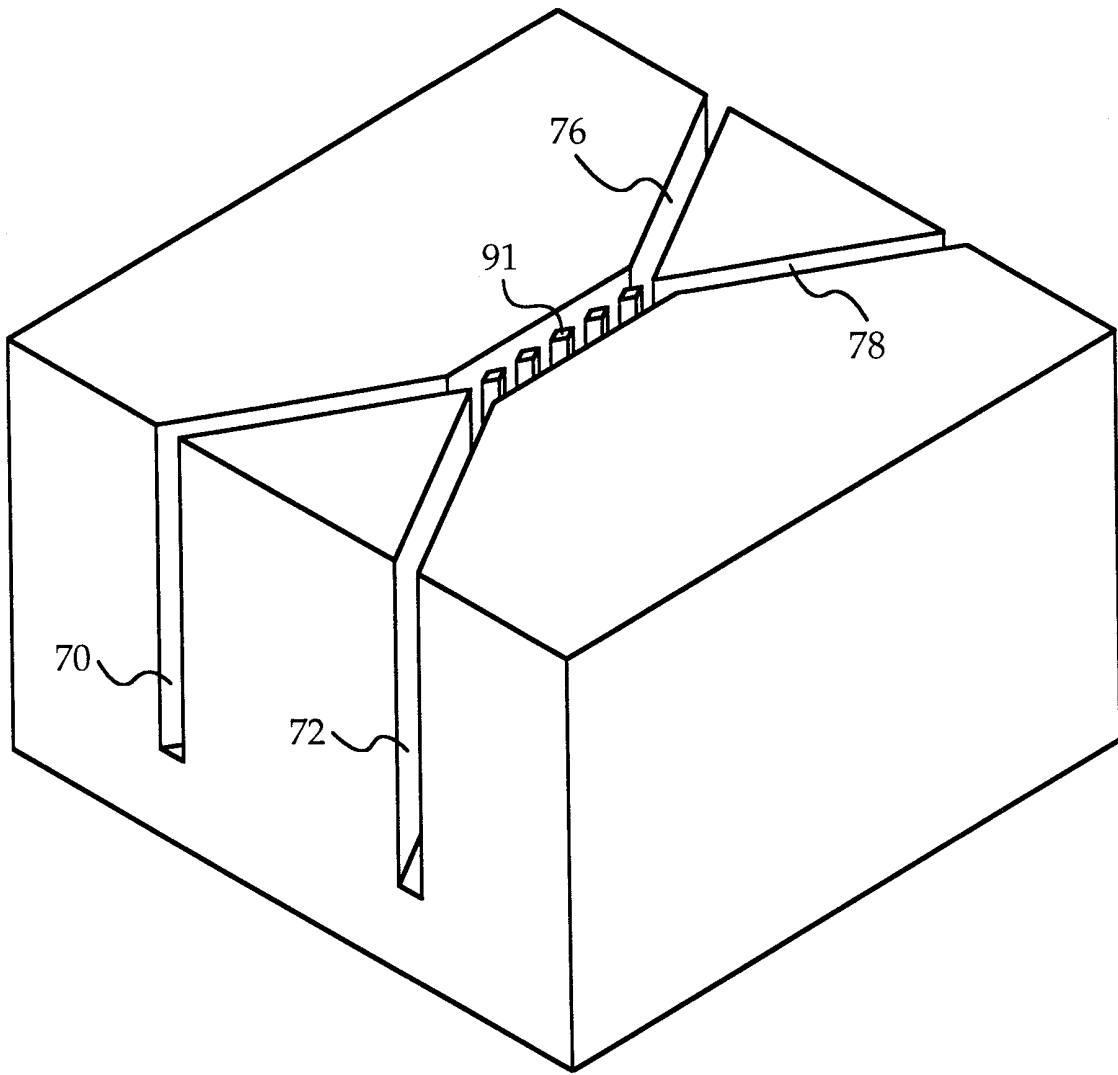

FIG. 5

9/15

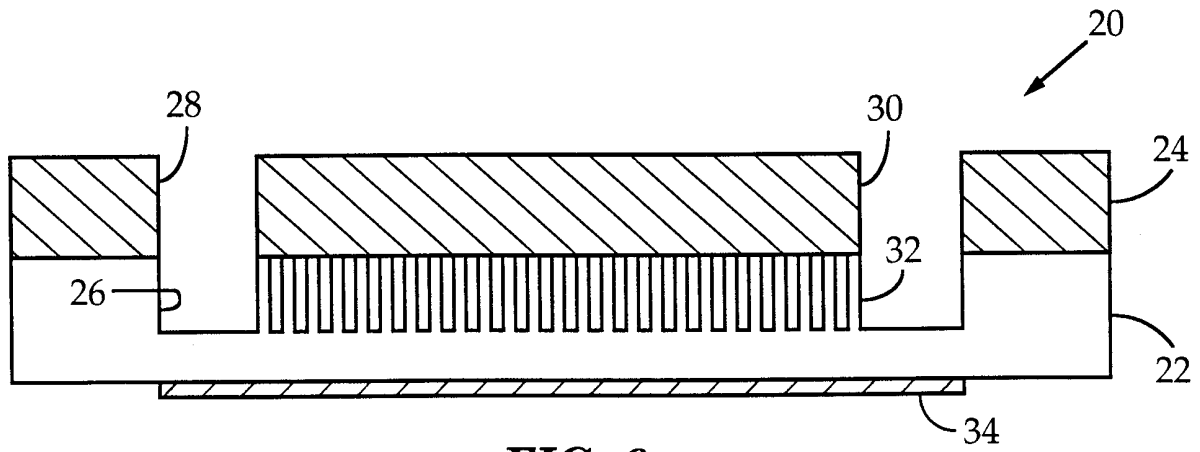

FIG. 6

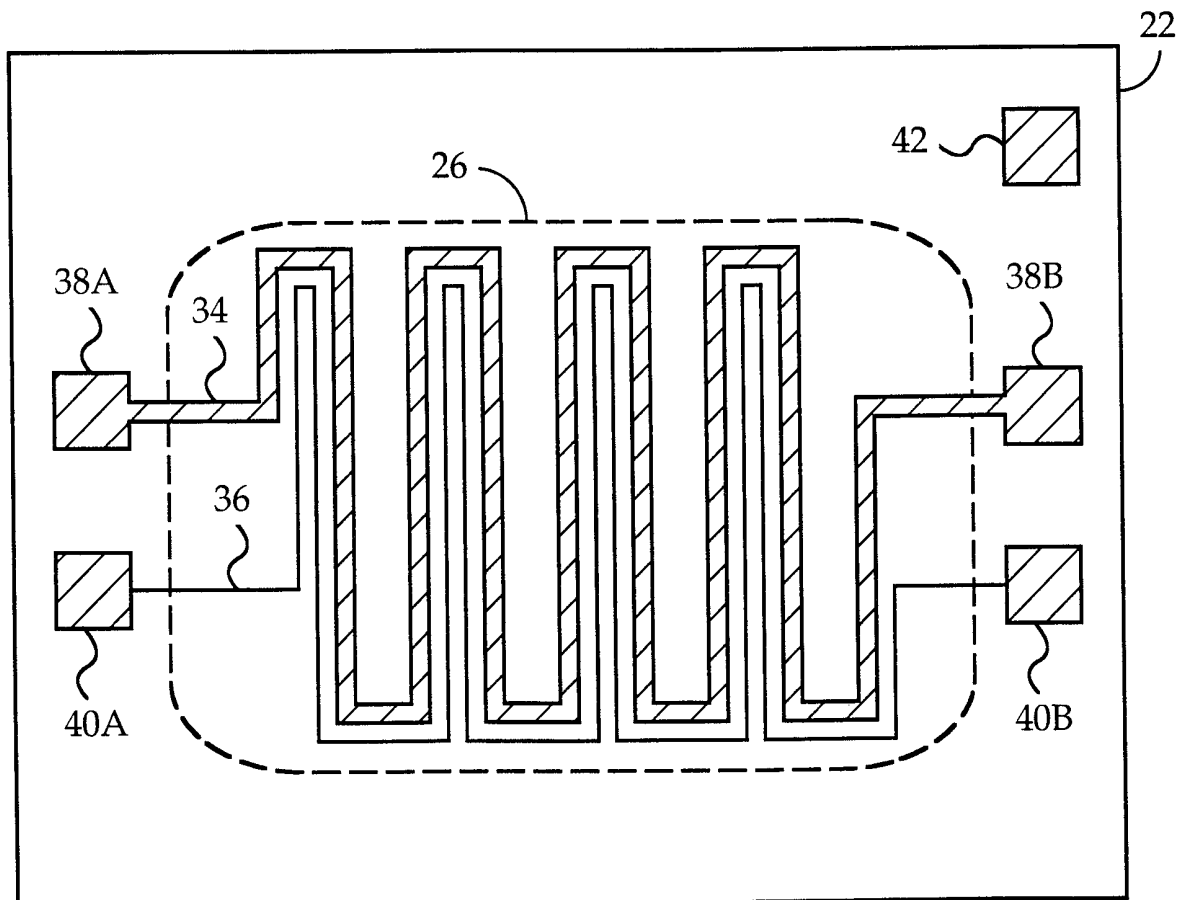

FIG. 7

10/15

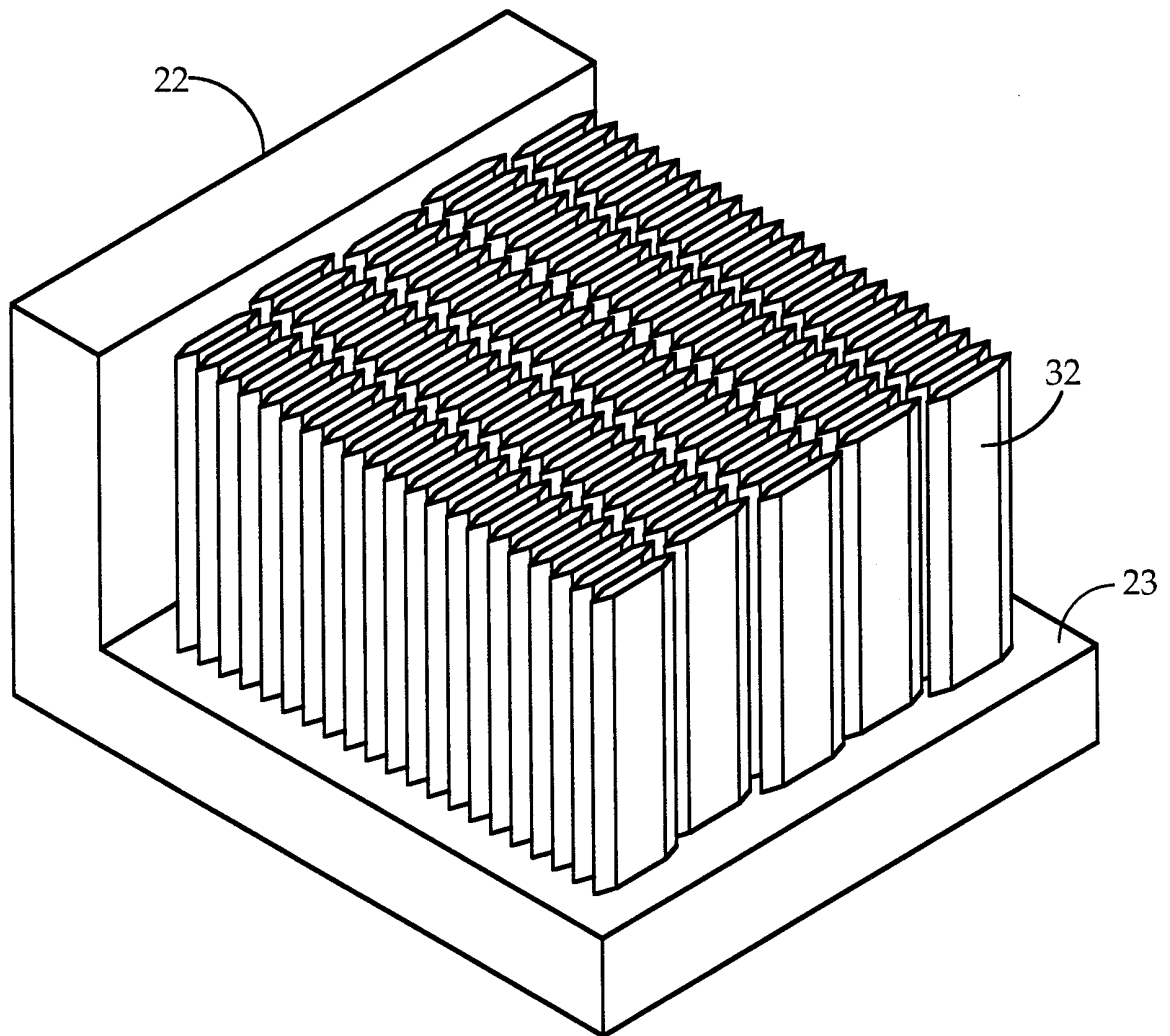

FIG. 8

11/15

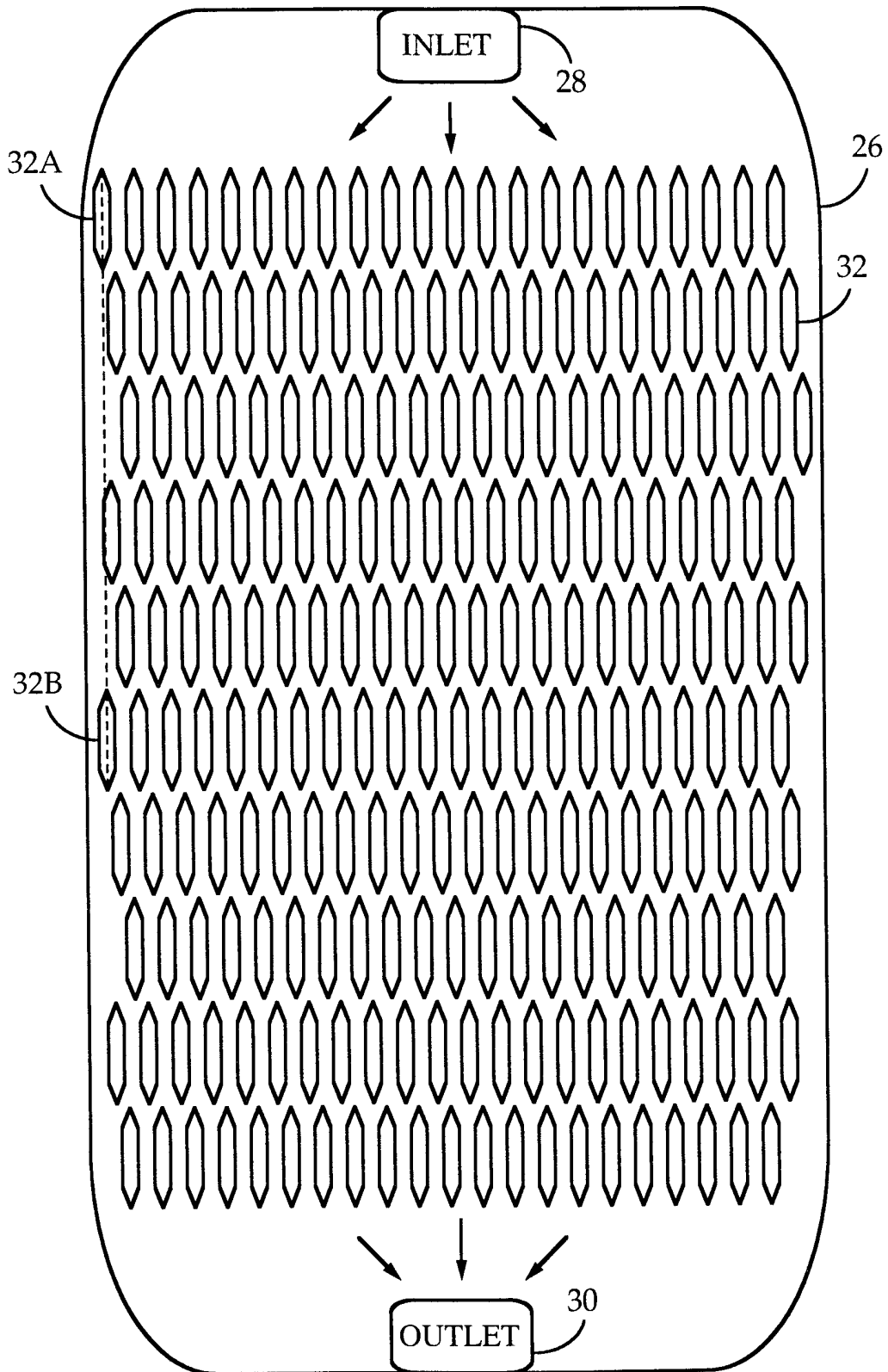

FIG. 9

12/15

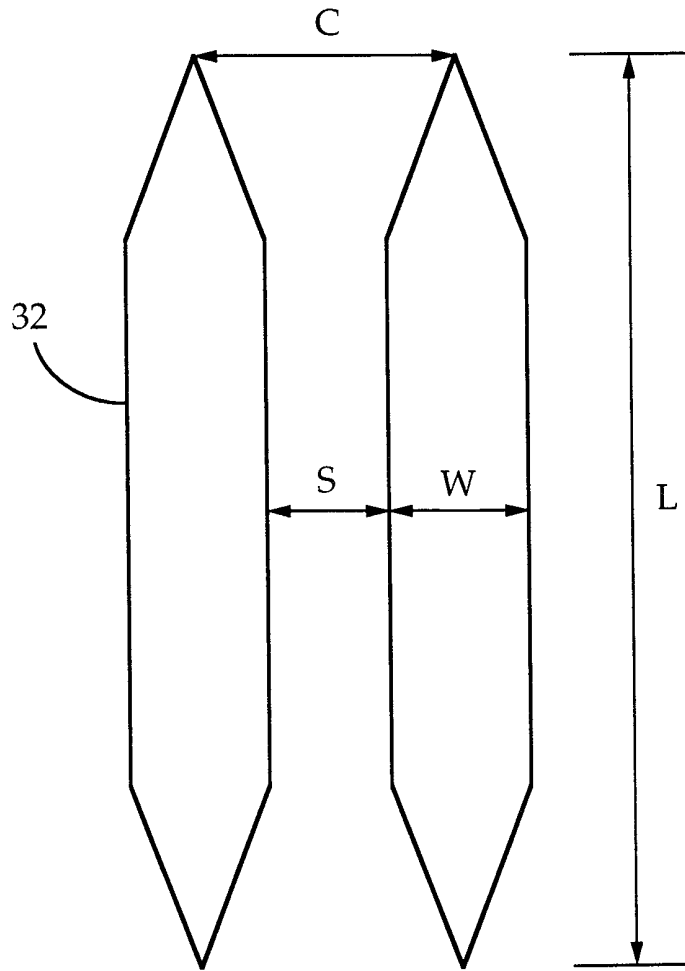

FIG. 10

13/15

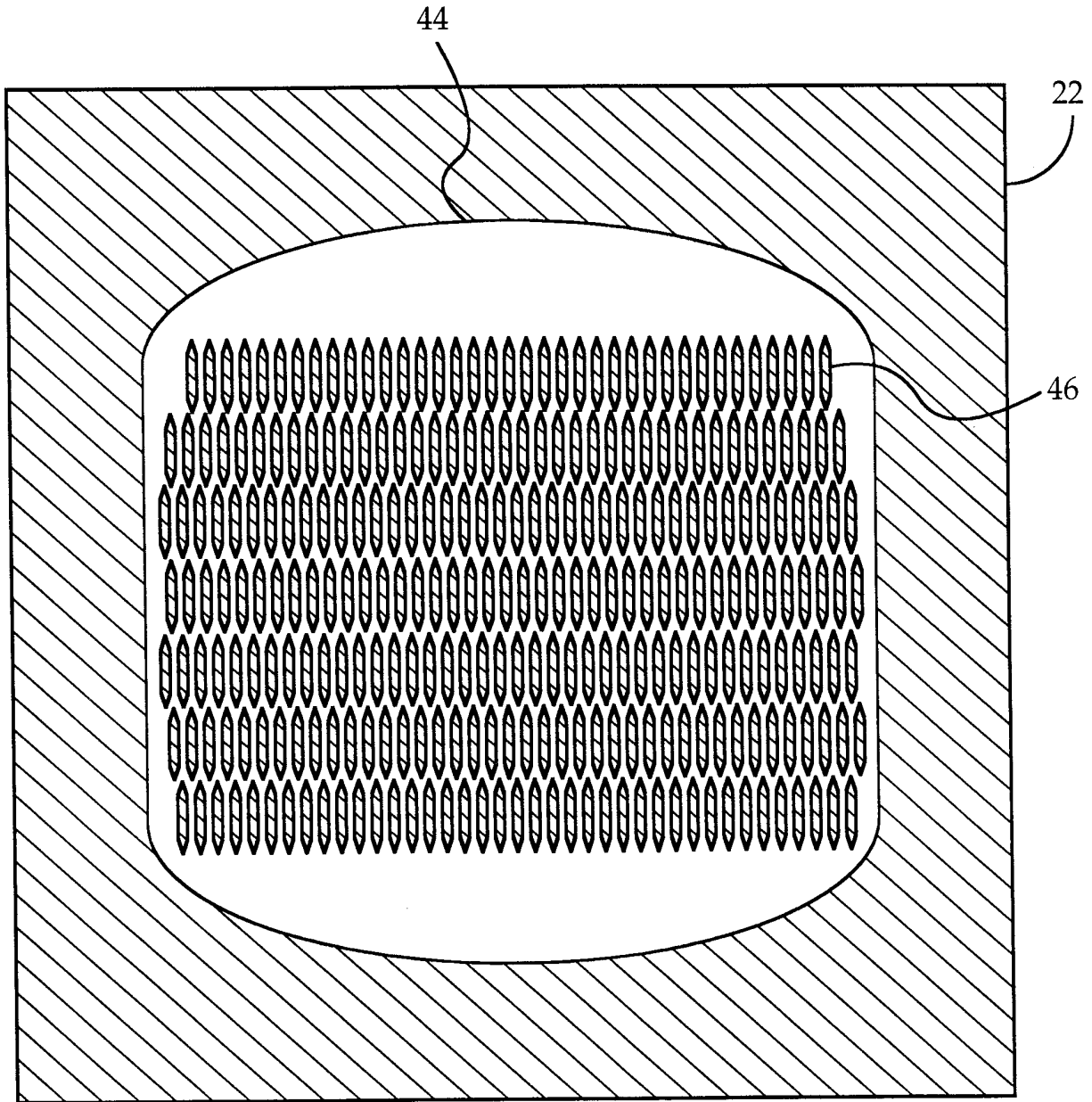

FIG. 11

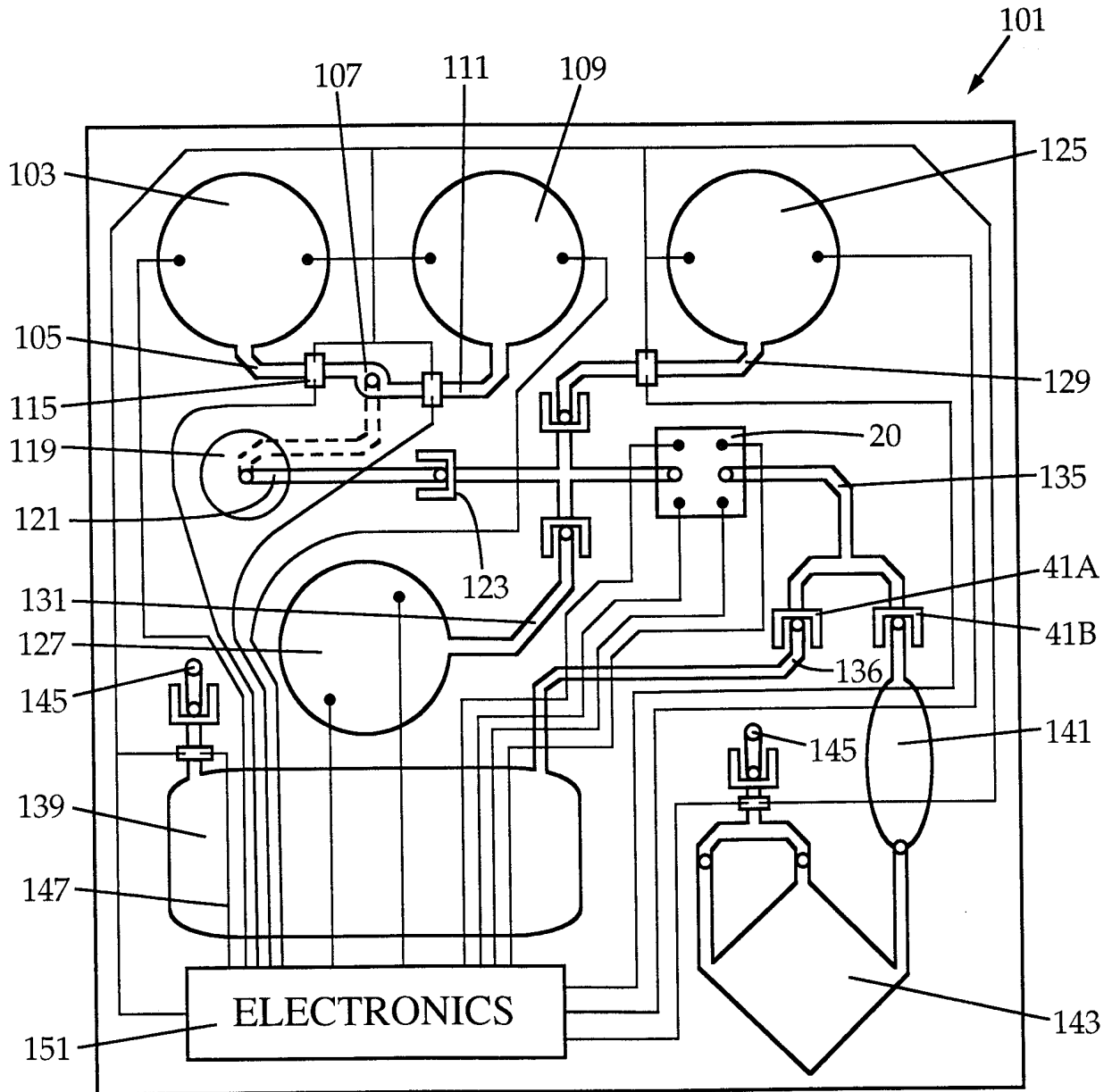

FIG. 12

15/15

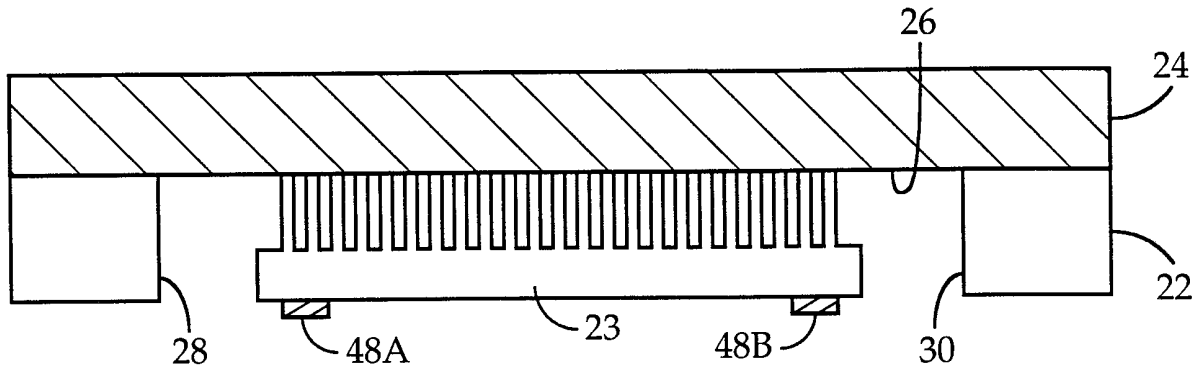

FIG. 13

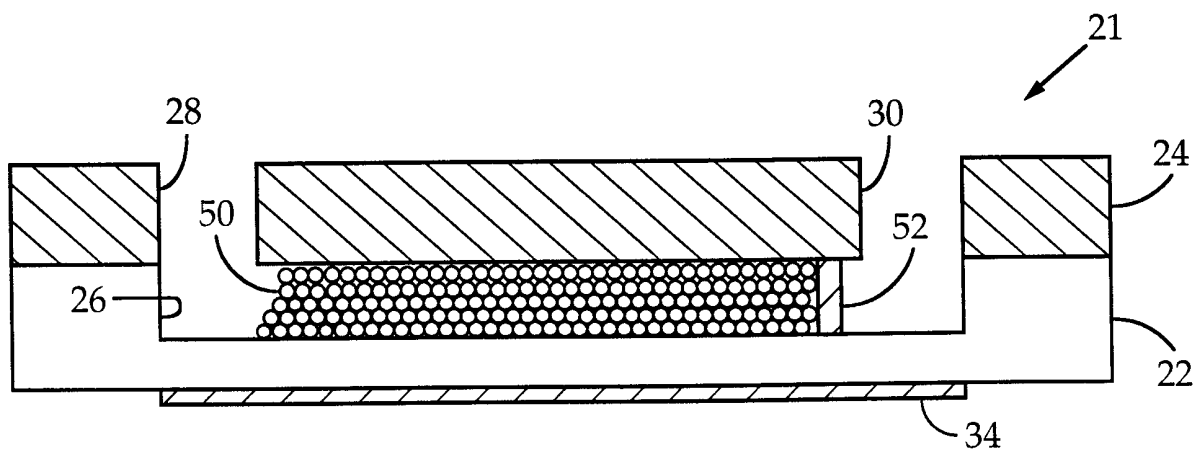

FIG. 14

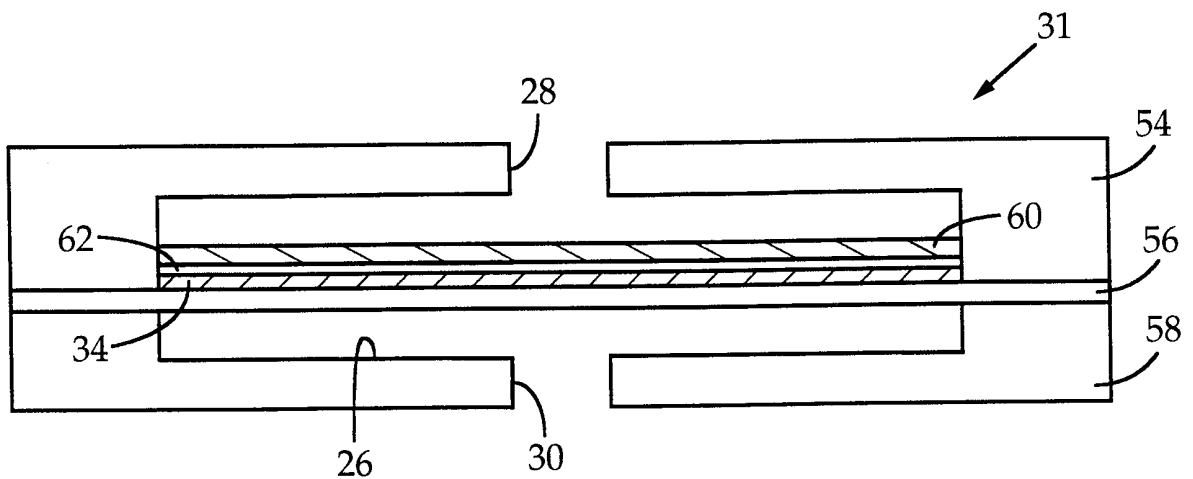

FIG. 15