

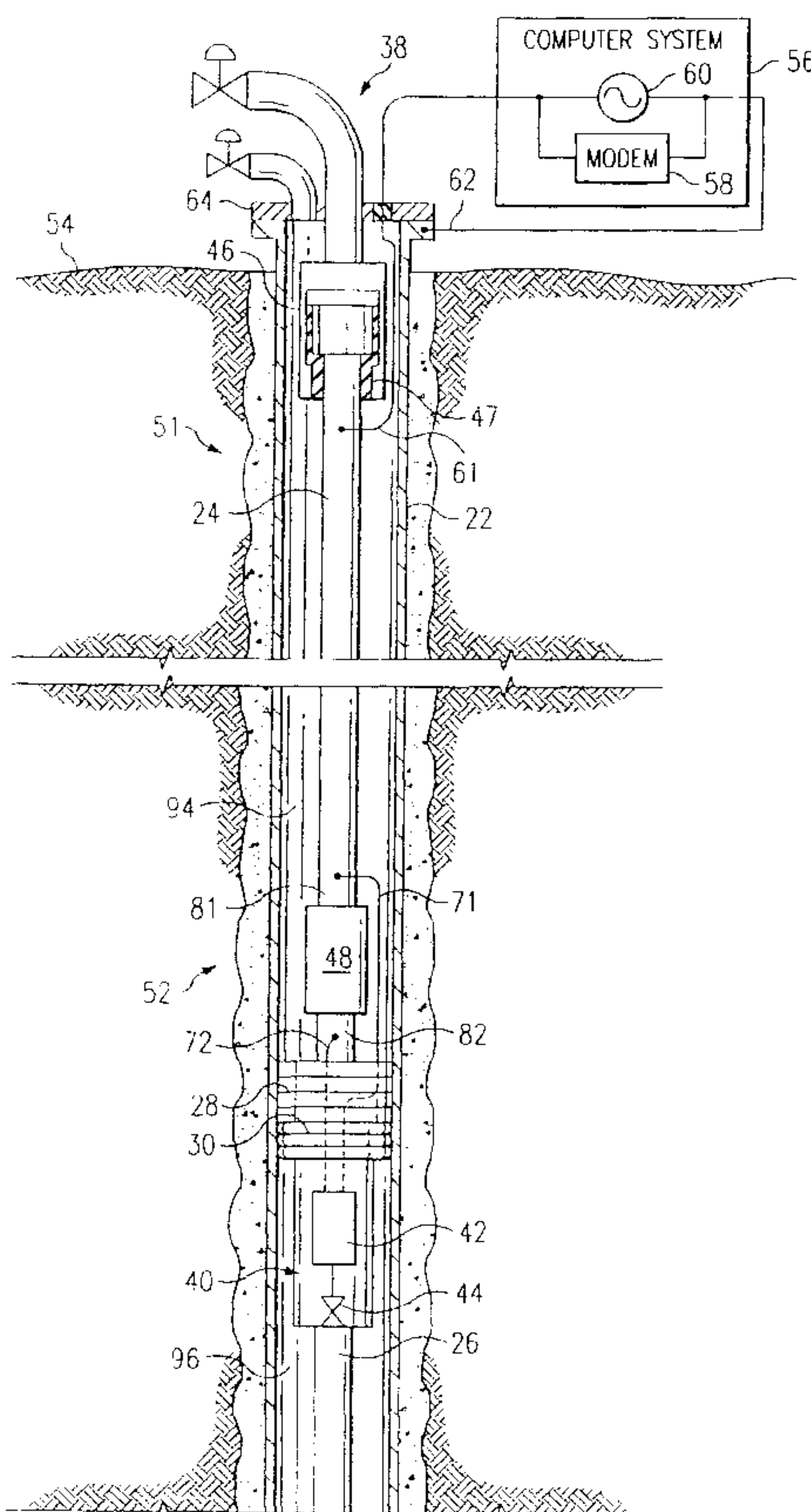

(86) Date de dépôt PCT/PCT Filing Date: 2001/03/02
 (87) Date publication PCT/PCT Publication Date: 2001/09/07
 (85) Entrée phase nationale/National Entry: 2002/08/29
 (86) N° demande PCT/PCT Application No.: US 2001/006984
 (87) N° publication PCT/PCT Publication No.: 2001/065067
 (30) Priorité/Priority: 2000/03/02 (60/186,375) US

(51) Cl.Int.⁷/Int.Cl.⁷ E21B 47/12, E21B 33/129
 (71) Demandeur/Applicant:
SHELL CANADA LIMITED, CA
 (72) Inventeurs/Inventors:
VINEGAR, HAROLD J., US;
BURNETT, ROBERT REX, US;
SAVAGE, WILLIAM MOUNTJOY, US;
CARL, FREDERICK GORDON JR., US;
HIRSCH, JOHN MICHELE, US
 (74) Agent: SMART & BIGGAR

(54) Titre : GARNITURE D'ETANCHEITE DE Puits DE PRODUCTION POUVANT ETRE COMMANDEE
 (54) Title: CONTROLLABLE PRODUCTION WELL PACKER



(57) Abrégé/Abstract:

An apparatus and method for operating an electrically powered device (42) in a packer (40) using the piping structure (24) of the well (38) as an electrical conductor for providing power and/or communications. The electrically powered device (42) may comprise an electrically controllable valve (44), a communications and control module, a modem, a sensor, and/or a tracer injection module.

(12) INTERNATIONAL APPLICATION PUBLISHED UNDER THE PATENT COOPERATION TREATY (PCT)

(19) World Intellectual Property Organization
International Bureau(43) International Publication Date
7 September 2001 (07.09.2001)

PCT

(10) International Publication Number
WO 01/65067 A1(51) International Patent Classification⁷: **E21B 47/12,**
33/129

(21) International Application Number: PCT/US01/06984

(22) International Filing Date: 2 March 2001 (02.03.2001)

(25) Filing Language: English

(26) Publication Language: English

(30) Priority Data:
60/186,375 2 March 2000 (02.03.2000) US(71) Applicant (for all designated States except US): **SHELL OIL COMPANY** [US/US]; One Shell Plaza, P.O. Box 2463, Houston, TX 77252-2463 (US).

(72) Inventors; and

(75) Inventors/Applicants (for US only): **VINEGAR,****Harold, J.** [US/US]; 5219 Yarwell, Houston, TX 77096 (US). **BURNETT, Robert, Rex** [US/US]; 20711 Flagmore Court, Katy, TX 77450 (US). **SAVAGE, William, Mountjoy** [US/US]; 8446 Ariel, Houston, TX 77074 (US). **CARL, Frederick, Gordon, Jr.** [US/US]; 8406 Edgemoor, Houston, TX 77036 (US). **HIRSCH, John, Michele** [US/US]; 1502 Cedarbrook Drive, Houston, TX 77055 (US).(74) Agent: **CHRISTENSEN, Del, S.**; Shell Oil Company, One Shell Plaza, P.O. Box 2463, Houston, TX 77252-2463 (US).

(81) Designated States (national): AE, AG, AL, AM, AT, AU, AZ, BA, BB, BG, BR, BY, BZ, CA, CH, CN, CR, CU, CZ, DE, DK, DM, DZ, EE, ES, FI, GB, GD, GE, GH, GM, HR, HU, ID, IL, IN, IS, JP, KE, KG, KP, KR, KZ, LC, LK, LR, LS, LT, LU, LV, MA, MD, MG, MK, MN, MW, MX, MZ,

[Continued on next page]

(54) Title: CONTROLLABLE PRODUCTION WELL PACKER

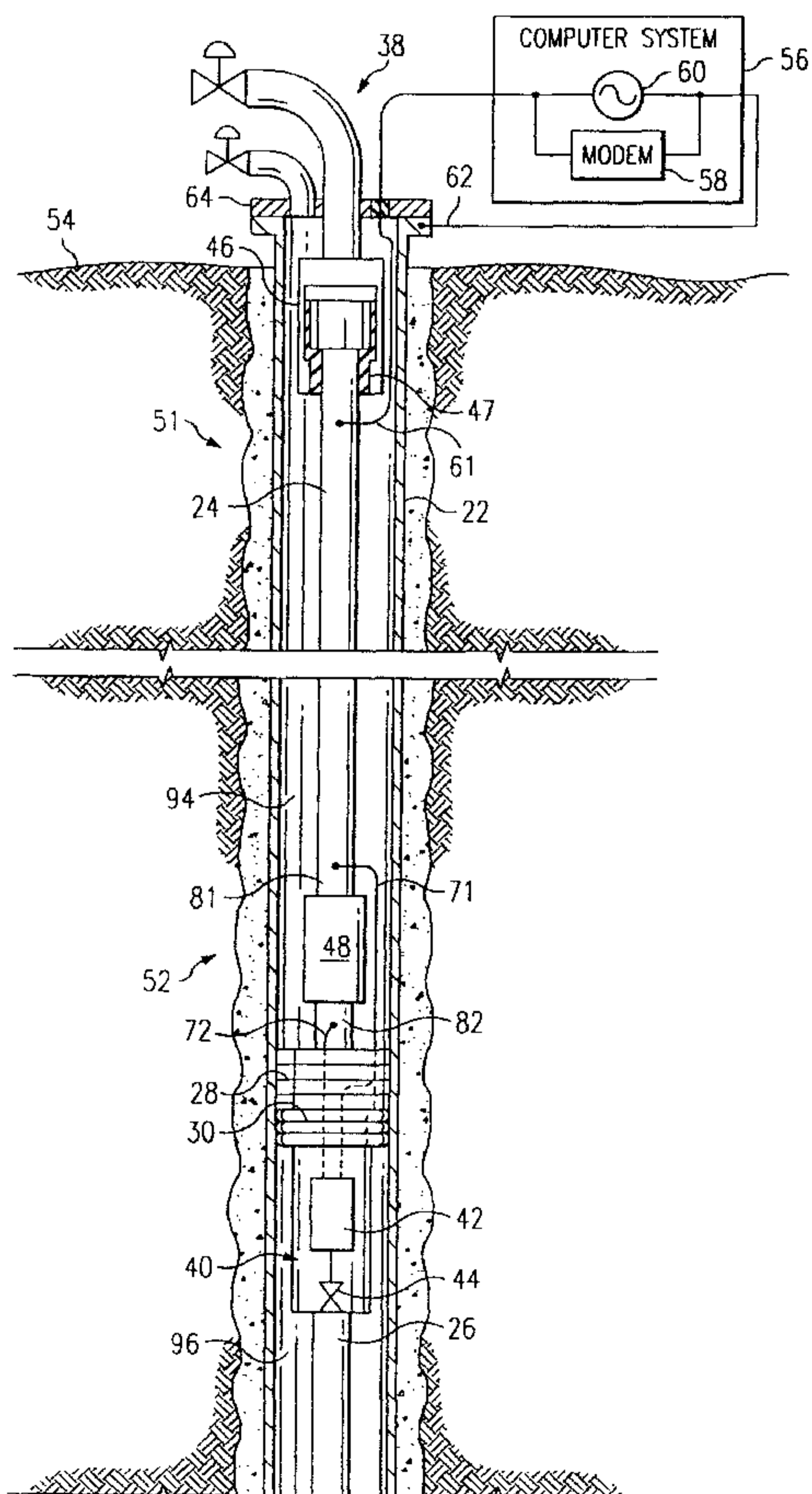

(57) Abstract: An apparatus and method for operating an electrically powered device (42) in a packer (40) using the piping structure (24) of the well (38) as an electrical conductor for providing power and/or communications. The electrically powered device (42) may comprise an electrically controllable valve (44), a communications and control module, a modem, a sensor, and/or a tracer injection module.

WO 01/65067 A1

5

CONTROLLABLE PRODUCTION WELL PACKER**CROSS-REFERENCES TO RELATED APPLICATIONS**

This application claims the benefit of the following U.S. Provisional Applications, all of which are hereby incorporated by reference:

COMMONLY OWNED AND PREVIOUSLY FILED U.S. PROVISIONAL PATENT APPLICATIONS			
T&K #	Serial Number	Title	Filing Date
TH 1599	60/177,999	Toroidal Choke Inductor for Wireless Communication and Control	Jan. 24, 2000
TH 1600	60/178,000	Ferromagnetic Choke in Wellhead	Jan. 24, 2000
TH 1602	60/178,001	Controllable Gas-Lift Well and Valve	Jan. 24, 2000
TH 1603	60/177,883	Permanent, Downhole, Wireless, Two-Way Telemetry Backbone Using Redundant Repeater, Spread Spectrum Arrays	Jan. 24, 2000
TH 1668	60/177,998	Petroleum Well Having Downhole Sensors, Communication, and Power	Jan. 24, 2000
TH 1669	60/177,997	System and Method for Fluid Flow Optimization	Jan. 24, 2000
TS 6185	60/181,322	A Method and Apparatus for the Optimal Predistortion of an Electromagnetic Signal in a Downhole Communications System	Feb. 9, 2000
TH 1599x	60/186,376	Toroidal Choke Inductor for Wireless Communication and Control	Mar. 2, 2000
TH 1600x	60/186,380	Ferromagnetic Choke in Wellhead	Mar. 2, 2000
TH 1601	60/186,505	Reservoir Production Control from Intelligent Well Data	Mar. 2, 2000
TH 1671	60/186,504	Tracer Injection in a Production Well	Mar. 2, 2000
TH 1672	60/186,379	Oilwell Casing Electrical Power Pick-Off Points	Mar. 2, 2000
TH 1673	60/186,394	Controllable Production Well Packer	Mar. 2, 2000
TH 1674	60/186,382	Use of Downhole High Pressure Gas in a Gas Lift Well	Mar. 2, 2000
TH 1675	60/186,503	Wireless Smart Well Casing	Mar. 2, 2000
TH 1677	60/186,527	Method for Downhole Power Management Using Energization from Distributed Batteries or Capacitors with Reconfigurable Discharge	Mar. 2, 2000

TH 1679	60/186,393	Wireless Downhole Well Interval Inflow and Injection Control	Mar. 2, 2000
TH 1681	60/186,394	Focused Through-Casing Resistivity Measurement	Mar. 2, 2000
TH 1704	60/186,531	Downhole Rotary Hydraulic Pressure for Valve Actuation	Mar. 2, 2000
TH 1705	60/186,377	Wireless Downhole Measurement and Control For Optimizing Gas Lift Well and Field Performance	Mar. 2, 2000
TH 1722	60/186, 381	Controlled Downhole Chemical Injection	Mar. 2, 2000
TH 1723	60/186,378	Wireless Power and Communications Cross-Bar Switch	Mar. 2, 2000

5

The current application shares some specification and figures with the following commonly owned and concurrently filed applications, all of which are hereby incorporated by reference:

COMMONLY OWNED AND CONCURRENTLY FILED U.S PATENT APPLICATIONS			
T&K #	Serial Number	Title	Filing Date
TH 1601US	09/_____	Reservoir Production Control from Intelligent Well Data	
TH 1671US	09/_____	Tracer Injection in a Production Well	
TH 1672US	09/_____	Oil Well Casing Electrical Power Pick-Off Points	
TH 1674US	09/_____	Use of Downhole High Pressure Gas in a Gas-Lift Well	
TH 1675US	09/_____	Wireless Smart Well Casing	
TH 1677US	09/_____	Method for Downhole Power Management Using Energization from Distributed Batteries or Capacitors with Reconfigurable Discharge	
TH 1679US	09/_____	Wireless Downhole Well Interval Inflow and Injection Control	
TH 1681US	09/_____	Focused Through-Casing Resistivity Measurement	
TH 1704US	09/_____	Downhole Rotary Hydraulic Pressure for Valve Actuation	
TH 1705US	09/_____	Wireless Downhole Measurement and Control For Optimizing Gas Lift Well and Field Performance	
TH 1722US	09/_____	Controlled Downhole Chemical Injection	
TH 1723US	09/_____	Wireless Power and Communications Cross-Bar Switch	

5

The current application shares some specification and figures with the following commonly owned and previously filed applications, all of which are hereby incorporated by reference:

COMMONLY OWNED AND PREVIOUSLY FILED U.S PATENT APPLICATIONS			
T&K #	Serial Number	Title	Filing Date
TH 1599US	09/ _____	Choke Inductor for Wireless Communication and Control	
TH 1600US	09/ _____	Induction Choke for Power Distribution in Piping Structure	
TH 1602US	09/ _____	Controllable Gas-Lift Well and Valve	
TH 1603US	09/ _____	Permanent Downhole, Wireless, Two-Way Telemetry Backbone Using Redundant Repeater	
TH 1668US	09/ _____	Petroleum Well Having Downhole Sensors, Communication, and Power	
TH 1669US	09/ _____	System and Method for Fluid Flow Optimization	
TH 1783US	09/ _____	Downhole Motorized Flow Control Valve	
TS 6185US	09/ _____	A Method and Apparatus for the Optimal Predistortion of an Electro Magnetic Signal in a Downhole Communications System	

10

The benefit of 35 U.S.C. § 120 is claimed for all of the above referenced commonly owned applications. The applications referenced in the tables above are referred to herein as the "Related Applications."

BACKGROUND OF THE INVENTION

15 Field of the Invention

The present invention relates to a controllable production well packer. In one aspect, it relates to a petroleum production well packer comprising an electrically powered device, in which the device may comprise an electrically controllable valve, a communications and control module, a sensor, a modem, a tracer injection module, or
20 any combination thereof.

5

Description of the Related Art

Petroleum wells (e.g., oil and/or gas wells) typically pass through formations containing multiple zones that may produce differing fluids, as well as impermeable zones. The fluid-bearing zones may produce saline or clear water, oil, gas, or a mixture of these components.

It is desirable and customary to maintain hydraulic isolation between zones so that the fluids produced from each zone may be received separately at the surface. Even if a particular zone is not producing petroleum products, it is usually necessary to ensure that fluids from that zone do not travel to other zones using the wellbore as a transport path, and to avoid contamination of the fluids in each zone.

The necessary isolation between zones is often provided by packers. A typical hydraulically set production packer of the prior art is schematically shown in FIG. 1. Packers are mechanical devices that close the annulus between the production tubing and the casing, and seal to both. Packers are typically installed at the time of well completion by attaching them to a tubing string as it is lowered into the well. Thus, during placement, the packer must pass freely within the casing. Once it is in place, a hydraulic actuator (energized and controlled from the surface) operates the sealing mechanism of the packer, which clamps the packer to the casing and effects a fluid-tight seal in the annular space between the tubing and the casing.

Packers may provide complete isolation between the annular spaces above and below them, or may be equipped with one or more preset mechanically-actuated valves to control flow past them. When control valves are included, however, their settings can only be altered by mechanically inserting a slick-line tool, which is inconvenient, slow, and relatively costly. Additionally, when there are multiple zones and multiple packers it is often impossible or impractical to reach the lowermost packers with a slick-line tool. This lack of a fast and inexpensive method for controlling valves in a packer is a constraint on well design and production operations.

Conventional packers are known such as described in U.S. Patents 6,148,915, 6,123,148, 3,566,963 and 3,602,305.

5 All references cited herein are incorporated by reference to the maximum extent allowable by law. To the extent a reference may not be fully incorporated herein, it is incorporated by reference for background purposes, and indicative of the knowledge of one of ordinary skill in the art.

BRIEF SUMMARY OF THE INVENTION

10 The problems and needs outlined above are largely solved and met by the present invention. In accordance with one aspect of the present invention, a packer adapted for use in a petroleum well, wherein the packer comprises an electrically powered device, is provided. The electrically powered device may comprise an electrically controllable valve adapted to control fluid communication from one side of the packer to another side
15 of the packer when the packer is operably installed. The electrically powered device may further comprise a communications and control module being electrically connected to the electrically controllable valve, wherein the module comprises a modem adapted to receive control commands encoded within communication signals. The module can be adapted to decode the control commands received by the modem and control the
20 movement of the valve using the control commands when the packer is operably installed. Alternatively, the electrically powered device may comprise a sensor adapted to detect at least one physical characteristic of a surrounding environment and generate data corresponding to the physical characteristic, as well as a modem adapted to receive the data from the sensor and electrically transmit the data in the form of an electrical
25 communication signal. Hence, the electrically powered device can comprise an electrically controllable valve, a sensor, a modem, a communications and control module, a tracer injection module, or any combination thereof.

In accordance with another aspect of the present invention, a petroleum production well incorporating the packer described above is provided. The petroleum
30 well comprises a piping structure, a source of time-varying current, an electrical return, an induction choke, and the packer. The piping structure of the well comprises an electrically conductive portion extending along at least part of the piping structure. The piping structure can comprise a production tubing string of the well. The source of time-varying current comprises two source terminals. A first of the source terminals is
35 electrically connected to the electrically conductive portion of the piping structure. The

5 electrical return electrically connects between the electrically conductive portion of the
piping structure and a second of the source terminals of the time-varying current source.
The electrical return can comprise a well casing of the well, part of the packer, another
packer, and/or a conductive fluid within the well. The induction choke is located about
10 part of the electrically conductive portion of the piping structure at a location along the
piping structure between the electrical connection location for the first source terminal
and the electrical connection location for the electrical return, such that a voltage
potential is formed between the electrically conductive portion of the piping structure on
a source-side of the induction choke, and the electrically conductive portion of the piping
15 structure on an electrical-return-side of the induction choke as well as the electrical
return when time-varying current flows through the electrically conductive portion of the
piping structure. The induction choke can comprise a ferromagnetic material. Also, the
induction choke need not be powered when its size, geometry, and magnetic properties
can provide sufficient magnetic inductance for developing the voltage potential desired.
The electrically powered device of the packer is electrically connected across the voltage
20 potential such that part of the time-varying current is routed through the device due to the
induction choke when the time-varying current flows through the electrically conductive
portion of the piping structure.

In accordance with yet another aspect of the present invention, a method of
producing petroleum products from a petroleum well comprising an electrically powered
25 packer is provided.

A conventional petroleum well includes a cased wellbore having a tubing string
positioned within and longitudinally extending within the casing. In a preferred
embodiment, a controllable packer is coupled to the tubing to provide a seal of the
annular space between the tubing and casing. A valve in the packer (and/or other
30 devices, such as sensors) is powered and controlled from the surface. Communication
signals and power are sent from the surface using the tubing and casing as conductors.
At least one induction choke is coupled about the tubing downhole to magnetically
inhibit alternating current flow through the tubing at a choke. An insulating tubing joint,
another induction choke, or another insulating means between the tubing and casing can
35 be located at the surface above a location where current and communication signals are
imparted to the tubing. Hence, most of the alternating current is contained between the

5 downhole choke and the insulating tubing joint, or between the chokes when two chokes are used.

The Related Applications describe alternative ways to provide electrical power from the surface to downhole modules, and to establish bidirectional communications for data and commands to be passed between the surface and downhole modules using surface and downhole modems. A preferred embodiment utilizes the production tubing and the well casing as the electrical conduction path between the surface and downhole equipment. The cost reduction and simplification of installation procedures which accrue from obviating the need for electrical cables to provide power, sensing, and control functions downhole allow wider deployment of active equipment downhole during production.

In the context of downhole packers, the ability to power and communicate with the packer has many advantages. Such a controllable packer in accordance with the present invention may incorporate sensors, with data from the sensors being received in real time at the surface. Similarly, the availability of power downhole, and the ability to pass commands from the surface to the controllable packer, allow electrically motorized mechanical components, such as flow control valves, to be included in packer design, thus increasing their flexibility in use. Notably, the control of such components in the controllable packer hereof is near real time, allowing packer flow control valves to be opened, closed, adjusted, or throttled constantly to contribute to the management of production.

In a preferred embodiment, a surface computer having a master modem can impart a communication signal to the tubing, and the communication signal is received at a slave modem downhole, which is electrically connected to or within the controllable packer. The communication signal can be received by the slave modem either directly or indirectly via one or more relay modems. Further, electric power can be input into the tubing string and received downhole to power the operation of sensors or other devices in the controllable packer. Preferably, the casing is used as a conductor for the electrical return.

In a preferred embodiment, a controllable valve in the packer regulates the fluid communication in the annulus between the casing and tubing. The electrical return path

5 can be provided along part of the controllable packer, and preferably by the expansion of the expansion slips into contact with the casing. Alternatively, the electrical return path may be via a conductive centralizer around the tubing which is insulated in its contact with the tubing, but is in electrical contact with the casing and electrically connected to the device in the packer.

10 In enhanced forms, the controllable packer includes one or more sensors downhole which are preferably in contact with the downhole modem and communicate with the surface computer via the tubing and/or well casing. Such sensors as temperature, pressure, acoustic, valve position, flow rates, and differential pressure
15 gauges can be advantageously used in many situations. The sensors supply measurements to the modem for transmission to the surface or directly to a programmable interface controller operating a downhole device, such as controllable valve for controlling the fluid flow through the packer.

In one embodiment, ferromagnetic induction chokes are coupled about the tubing to act as a series impedance to current flow on the tubing. In a preferred form, an upper
20 ferromagnetic choke is placed around the tubing below the casing hanger, and the current and communication signals are imparted to the tubing below the upper ferromagnetic choke. A lower ferromagnetic choke is placed downhole around the tubing with the controllable packer electrically coupled to the tubing above the lower ferromagnetic choke, although the controllable packer may be mechanically coupled to the tubing
25 below the lower ferromagnetic choke instead.

Preferably, a surface computer is coupled via a surface master modem and the tubing to the downhole slave modem of the controllable packer. The surface computer can receive measurements from a variety of sources (e.g., downhole sensors), measurements of the oil output from the well, and measurements of the compressed gas
30 input to the well in the case of a gas lift well. Using such measurements, the computer can compute desired positions of the controllable valve in the packer, and more particularly, the optimum amount of fluid communication to permit into the annulus inside the casing.

Construction of such a petroleum well is designed to be as similar to conventional
35 construction methodology as possible. That is, after casing the well, a packer is typically

5 set to isolate each zone. In a production well, there may be several oil producing zones,
water producing zones, impermeable zones, and thief zones. It is desirable to prevent or
permit communication between the zones. For example when implementing the present
invention, the tubing string is fed through the casing into communication with the
production zone, with controllable packers defining the production zone. As the tubing
10 string is made up at the surface, a lower ferromagnetic choke is placed around one of the
conventional tubing strings for positioning above the lowermost controllable packer. In
the sections of the tubing strings where it is desired, another packer is coupled to the
tubing string to isolate zones. Controllable gas lift valves or sensor pods also may be
coupled to the tubing as desired by insertion in a side pocket mandrel (tubing conveyed)
15 and corresponding induction chokes as needed. The tubing string is made up to the
surface where an upper ferromagnetic induction choke is again placed around the tubing
string below the casing hanger. Communication and power leads are then connected to
the tubing string below the upper choke. In an enhanced form, an electrically insulating
joint is used instead of the upper induction choke.

20 A sensor and communication pod can be incorporated into the controllable packer
of the present invention without the necessity of including a controllable valve or other
control device. That is, an electronics module having pressure, temperature or acoustic
sensors, power supply, and a modem can be incorporated into the packer for
communication to the surface computer using the tubing and casing as conductors.

25 **BRIEF DESCRIPTION OF THE DRAWINGS**

Other objects and advantages of the invention will become apparent upon
reading the following detailed description and upon referencing the accompanying
drawings, in which:

FIG. 1 is a schematic showing a typical packer of the prior art;

30 FIG. 2 is a schematic showing a petroleum production well in accordance with a
preferred embodiment of the present invention;

FIG. 3 is a simplified electrical schematic of the embodiment shown in FIG. 2;
and

5 FIG. 4 is an enlarged schematic showing a controllable packer, from FIG. 2, comprising an electrically controllable valve.

DETAILED DESCRIPTION OF THE INVENTION

Referring now to the drawings, wherein like reference numbers are used herein to designate like elements throughout the various views, a preferred embodiment of the present invention is illustrated and further described, and other possible embodiments of the present invention are described. The figures are not necessarily drawn to scale, and in some instances the drawings have been exaggerated and/or simplified in places for illustrative purposes only. One of ordinary skill in the art will appreciate the many possible applications and variations of the present invention based on the following examples of possible embodiments of the present invention, as well as based on those embodiments illustrated and discussed in the Related Applications, which are incorporated by reference herein to the maximum extent allowed by law.

As used in the present application, a "piping structure" can be one single pipe, a tubing string, a well casing, a pumping rod, a series of interconnected pipes, rods, rails, trusses, lattices, supports, a branch or lateral extension of a well, a network of interconnected pipes, or other similar structures known to one of ordinary skill in the art. The preferred embodiment makes use of the invention in the context of a petroleum well where the piping structure comprises tubular, metallic, electrically-conductive pipe or tubing strings, but the invention is not so limited. For the present invention, at least a portion of the piping structure needs to be electrically conductive, such electrically conductive portion may be the entire piping structure (e.g., steel pipes, copper pipes) or a longitudinal extending electrically conductive portion combined with a longitudinally extending non-conductive portion. In other words, an electrically conductive piping structure is one that provides an electrical conducting path from a first portion where a power source is electrically connected to a second portion where a device and/or electrical return is electrically connected. The piping structure will typically be conventional round metal tubing, but the cross-section geometry of the piping structure, or any portion thereof, can vary in shape (e.g., round, rectangular, square, oval) and size (e.g., length, diameter, wall thickness) along any portion of the piping structure. Hence, a piping structure must have an electrically conductive portion extending from a first

5 portion of the piping structure to a second portion of the piping structure, wherein the first portion is distally spaced from the second portion along the piping structure.

Note that the terms "first portion" and "second portion" as used herein are each defined generally to call out a portion, section, or region of a piping structure that may or may not extend along the piping structure, that can be located at any chosen place along
10 the piping structure, and that may or may not encompass the most proximate ends of the piping structure.

Similarly, in accordance with conventional terminology of oilfield practice, the descriptors "upper", "lower", "uphole" and "downhole" are relative and refer to distance along hole depth from the surface, which in deviated or horizontal wells may or may not
15 accord with vertical elevation measured with respect to a survey datum.

Also note that the term "modem" is used herein to generically refer to any communications device for transmitting and/or receiving electrical communication signals via an electrical conductor (e.g., metal). Hence, the term "modem" as used herein is not limited to the acronym for a modulator (device that converts a voice or data
20 signal into a form that can be transmitted)/demodulator (a device that recovers an original signal after it has modulated a high frequency carrier). Also, the term "modem" as used herein is not limited to conventional computer modems that convert digital signals to analog signals and vice versa (e.g., to send digital data signals over the analog Public Switched Telephone Network). For example, if a sensor outputs measurements in
25 an analog format, then such measurements may only need to be modulated (e.g., spread spectrum modulation) and transmitted--hence no analog/digital conversion needed. As another example, a relay/slave modem or communication device may only need to identify, filter, amplify, and/or retransmit a signal received.

As used in the present application, "wireless" means the absence of a
30 conventional, insulated wire conductor e.g. extending from a downhole device to the surface. Using the tubing and/or casing as a conductor is considered "wireless." The term "valve" as used herein generally refers to any device that functions to regulate the flow of a fluid. Examples of valves include, but are not limited to, bellows-type gas-lift valves and controllable gas-lift valves, each of which may be used to regulate the flow of
35 lift gas into a tubing string of a well. The internal workings of valves can vary greatly,

5 and in the present application, it is not intended to limit the valves described to any particular configuration, so long as the valve functions to regulate flow. Some of the various types of flow regulating mechanisms include, but are not limited to, ball valve configurations, needle valve configurations, gate valve configurations, and cage valve configurations. The methods of installation for valves discussed in the present
10 application can vary widely.

The term “electrically controllable valve” as used herein generally refers to a “valve” (as just described) that can be opened, closed, adjusted, altered, or throttled continuously in response to an electrical control signal (e.g., signal from a surface computer or from a downhole electronic controller module). The mechanism that
15 actually moves the valve position can comprise, but is not limited to: an electric motor; an electric servo; an electric solenoid; an electric switch; a hydraulic actuator controlled by at least one electrical servo, electrical motor, electrical switch, electric solenoid, or combinations thereof; a pneumatic actuator controlled by at least one electrical servo, electrical motor, electrical switch, electric solenoid, or combinations thereof; or a spring
20 biased device in combination with at least one electrical servo, electrical motor, electrical switch, electric solenoid, or combinations thereof. An “electrically controllable valve” may or may not include a position feedback sensor for providing a feedback signal corresponding to the actual position of the valve.

The term “sensor” as used herein refers to any device that detects, determines,
25 monitors, records, or otherwise senses the absolute value of or a change in a physical quantity. A sensor as described herein can be used to measure physical quantities including, but not limited to: temperature, pressure (both absolute and differential), flow rate, seismic data, acoustic data, pH level, salinity levels, valve positions, or almost any other physical data.

30 FIG. 1 is a schematic showing a conventional hydraulically set production packer 20 of the prior art set within a well casing 22 of a well. The packer 20 of FIG. 1 is threaded to a production tubing string 24. The conventional packer 20 has a tail piece 26 that may terminate with an open or closed end for the lowest packer in the completed well, or the tail piece 26 may be threaded onto tubing (not shown) that passes to lower
35 regions of the well. The conventional packer 20 has a section of slips 28 and a seal

5 section 30. Both the slips 28 and the seal section 30 can pass freely inside the well casing 22 during placement, and are operated by a hydraulic actuator 32. When the packer 20 is at its final location in the casing 22, the hydraulic actuator 32 is used to exert mechanical forces on the slips 28 and the seals 30 causing them to expand against the casing. The slips 28 lock the packer 20 in place by gripping the internal surface of the casing 22 so that the packer cannot be displaced by differential pressure between the spaces above and below the packer. The seal section 30 creates a liquid-tight seal between the spaces above and below the packer 20. The hydraulic actuator 32 is operated using high-pressure oil supplied from the surface (not shown) by a control tube 34. However, the conventional packer 20 does not comprise an electrically powered device.

FIG. 2 is a schematic showing a petroleum production well 38 in accordance with a preferred embodiment of the present invention. The petroleum production well 38 shown in FIG. 2 is similar to a conventional well in construction, but with the incorporation of the present invention. In this example, a packer 40 comprising an electrically powered device 42 is placed in the well 38 in the same manner as a conventional packer 20 would be—to separate zones in a formation. In the preferred embodiment, the electrically powered device 42 of the packer 40 comprises an electrically controllable valve 44 that acts as a bypass valve, as shown in more detail in FIG. 4 and described further below.

25 In a preferred embodiment, the piping structure comprises part of a production tubing string 24, and the electrical return comprises part of a well casing 22. An insulating tubing joint 146 and a ferromagnetic induction choke 48 are used in this preferred embodiment. The insulating joint 146 is incorporated close to the wellhead to electrically insulate the lower sections of tubing 24 from casing 22. Thus, the insulating joint 146 prevents an electrical short-circuit between the lower sections of tubing 24 and casing 22 at the tubing hanger 46. The hanger 46 provides mechanical coupling and support of the tubing 24 by transferring the weight load of the tubing 24 to the casing 22. The induction choke 48 is attached about the tubing string 24 at a second portion 52 downhole above the packer 40. A computer system 56 comprising a master modem 58 and a source of time-varying current 60 is electrically connected to the tubing string 24 below the insulating tubing joint 146 by a first source terminal 61. The first source

5 terminal 61 is insulated from the hanger 46 where it passes through it. A second source
terminal 62 is electrically connected to the well casing 22, either directly (as in FIG. 2)
or via the hanger 46 (arrangement not shown). In alternative to or in addition to the
insulating tubing joint 146, another induction choke (not shown) can be placed about the
tubing 24 above the electrical connection location for the first source terminal 61 to the
10 tubing.

The time-varying current source 60 provides the current, which carries power and
communication signals downhole. The time-varying current is preferably alternating
current (AC), but it can also be a varying direct current (DC). The communication
signals can be generated by the master modem 58 and embedded within the current
15 produced by the source 60. Preferably, the communication signal is a spread spectrum
signal, but other forms of modulation could be used in alternative.

The electrically powered device 42 in the packer 40 comprises two device
terminals 71, 72, and there can be other device terminals as needed for other
embodiments or applications. A first device terminal 71 is electrically connected to the
20 tubing 24 on a source-side 81 of the induction choke 48, which in this case is above the
induction choke. Similarly, a second device terminal 72 is electrically connected to the
tubing 24 on an electrical-return-side 82 of the induction choke 48, which in this case is
below the induction choke. In this preferred embodiment, the slips 28 of the packer 40
provide the electrical connection between the tubing 24 and the well casing 22.
25 However, as will be clear to one of ordinary skill in the art, the electrical connection
between the tubing 24 and the well casing 22 can be accomplished in numerous ways,
some of which can be seen in the Related Applications, including (but not limited to):
another packer (conventional or controllable); conductive fluid in the annulus between
the tubing and the well casing; a conductive centralizer; or any combination thereof.
30 Hence, an electrical circuit is formed using the tubing 24 and the well casing 22 as
conductors to the downhole device 42 within the packer 40.

FIG. 3 illustrates a simplified electrical schematic of the electrical circuit formed
in the well 38 of FIG. 2. The insulating tubing joint 146 and the induction choke 48
effectively create an isolated section of the tubing string 24 to contain most of the time-
35 varying current between them. Accordingly, a voltage potential develops between the

5 isolated section of tubing 24 and the well casing 22 when AC flows through the tubing string. Likewise, the voltage potential also forms between tubing 24 on the source-side 81 of the induction choke 48 and the tubing 24 on the electrical-return-side 82 of the induction choke 48 when AC flows through the tubing string. In the preferred
10 embodiment, the electrically powered device 42 in the packer 40 is electrically connected across the voltage potential between the source-side 81 and the electrical-return-side 82 of the tubing 24. However in alternative, the device 42 can be electrically connected across the voltage potential between the tubing 24 and the casing 22, or the voltage potential between the tubing 24 and part of the packer 40 (e.g., slips 28), if that part of the packer is electrically contacting the well casing 22. Thus, part of the current that
15 travels through the tubing 24 and casing 22 is routed through the device 42 due to the induction choke 48.

As is made clear by consideration of the electrical equivalent circuit diagram of FIG. 3, centralizers which are installed on the tubing between isolation device 47 and choke 48 must not provide an electrically conductive path between tubing 24 and casing
20 22. Suitable centralizers may be composed of solid molded or machined plastic, or may be of the bow-spring type provided these are furnished with appropriate insulating elements. Many suitable and alternative design implementations of such centralizers will be clear to those of average skill in the art.

Other alternative ways to develop an electrical circuit using a piping structure and at least one induction choke are described in the Related Applications, many of which
25 can be applied in conjunction with the present invention to provide power and/or communications to the electrically powered device 42 of the packer 40 and to form other embodiments of the present invention.

Turning to FIG. 4, which shows more details of the packer 40 of FIG. 2, it is seen
30 that the controllable packer 40 is similar to the conventional packer 20 (shown in FIG. 1), but with the addition of an electrically powered device 42 comprising an electrically controllable valve 44 and a communications and control module 84. The communications and control module 84 is powered from and communicates with the computer system 56 at the surface 54 via the tubing 24 and/or the casing 22. The
35 communications and control module 84 may comprise a modem 86, a power transformer

5 (not shown), a microprocessor (not shown), and/or other various electronic components
(not shown) as needed for an embodiment. The communications and control module 84
receives electrical signals from the computer system 56 at the surface 54 and decodes
commands for controlling the electrically controlled valve 44, which acts as a bypass
valve. Using the decoded commands, the communications and control module 84
10 controls a low current electric motor that actuates the movement of the bypass valve 44.
Thus, the valve 44 can be opened, closed, adjusted, altered, or throttled continuously by
the computer system 56 from the surface 54 via the tubing 24 and well casing 22.

The bypass valve 44 of FIG. 4 controls flow through a bypass tube 88, which
connects inlet and outlet ports 90, 92 at the bottom and top of the packer 40. The
15 ports 90, 92 communicate freely with the annular spaces 94, 96 (between the casing 22
and the tubing 24), above and below the packer 40. The bypass control valve 44
therefore controls fluid exchange between these spaces 94, 96, and this exchange may be
altered in real time using commands sent from the computer system 56 and received by
the controllable packer 40.

20 The mechanical arrangement of the packer 40 depicted in FIG. 4 is illustrative,
and alternative embodiments having other mechanical features providing the same
functional needs of a packer (i.e., fluidly isolating and sealing one casing section from
another casing section in a well, and in the case of a controllable packer, regulating and
controlling fluid flow between these isolated casing sections) are possible and
25 encompassed within the present invention. For instance, the inlet and outlet ports 90, 92
may be exchanged to pass fluids from the annular space 94 above the packer 40 to the
space 96 below the packer. Also, the communications and control module 84 and the
bypass control valve 44 may be located in upper portion of the packer 40, above the
slips 28. The controllable packer 40 may also comprise sensors (not shown) electrically
30 connected to or within the communication and control module 84, to measure pressures
or temperatures in the annuli 94, 96 or within the production tubing 24. Hence, the
measurements can be transmitted to the computer system 56 at the surface 54 using the
communications and control module 84, providing real time data on downhole
conditions. Also the setting and unsetting mechanism of the packer slips may be
35 actuated by one or more motors driven and controlled by power and commands received
by module 84.

5 In other possible embodiments of the present invention, the electrically powered
device 42 of the packer 40 may comprise: a modem 86; a sensor (not shown); a
microprocessor (not shown); a packer valve 44; a tracer injection module (not shown); an
electrically controllable gas-lift valve (e.g., for controlling the flow of gas from the
annulus to inside the tubing) (not shown); a tubing valve (e.g., for varying the flow of a
10 tubing section, such as an application having multiple branches or laterals) (not shown);
a communications and control module 84; a logic circuit (not shown); a relay modem
(not shown); other electronic components as needed (not shown); or any combination
thereof.

 Also in other possible embodiments of the present invention, there may be
15 multiple controllable packers and/or multiple induction chokes. In an application where
there are multiple controllable packers or additional conventional packers combined with
the present invention, it may be necessary to electrically insulate some or all of the
packers so that a packer does not act as a short between the piping structure (e.g.,
tubing 24) and the electrical return (e.g., casing 22) where such a short is not desired.
20 Such electrical insulation of a packer may be achieved in various ways apparent to one of
ordinary skill in the art, including (but not limited to): an insulating sleeve about the
tubing at the packer location; a rubber or urethane portion at the radial extent of the
packer slips; an insulating coating on the tubing at the packer location; forming the slips
from non-electrically-conductive materials; other known insulating means; or any
25 combination thereof. The present invention also can be applied to other types of wells
(other than petroleum wells), such as a water well.

 It will be appreciated by those skilled in the art having the benefit of this
disclosure that this invention provides a packer comprising an electrically powered
device, as well as a petroleum production well incorporating such a packer. It should be
30 understood that the drawings and detailed description herein are to be regarded in an
illustrative rather than a restrictive manner, and are not intended to limit the invention to
the particular forms and examples disclosed. On the contrary, the invention includes any
further modifications, changes, rearrangements, substitutions, alternatives, design
choices, and embodiments apparent to those of ordinary skill in the art, without departing
35 from the spirit and scope of this invention, as defined by the following claims. Thus, it is
intended that the following claims be interpreted to embrace all such further

5 modifications, changes, rearrangements, substitutions, alternatives, design choices, and embodiments.

5 **THE INVENTION CLAIMED IS:**

1. A packer adapted for use in a well, said packer including an electrically powered device adapted for receiving AC power from the surface using at least one of the tubing or casing as a conductor.

10

2. A packer in accordance with claim 1, wherein said electrically powered device comprises an electrically controllable valve adapted to control fluid communication from one side of said packer to another side of said packer.

15

3. A packer in accordance with claim 2, wherein said electrically powered device further comprises a communications and control module being electrically connected to said electrically controllable valve, said module comprising a modem adapted to receive control commands encoded within communication signals, and said module being adapted to decode said control commands received by said modem and control the movement of said valve using said control commands when said packer is operably installed.

20

4. A packer in accordance with claim 1, wherein said electrically powered device comprises:

25

a sensor adapted to detect at least one physical characteristic of a surrounding environment and generate data corresponding to said physical characteristic; and

a modem adapted to receive said data from said sensor and electrically transmit said data in the form of an electrical communication signal.

5

5. A petroleum well for producing petroleum products, comprising:
a piping structure comprising an electrically conductive portion extending along
at least part of said piping structure;
10 a source of time-varying current electrically connected to said electrically
conductive portion of said piping structure;
an electrical return; and
a packer including an electrically powered device, said electrically powered
device being electrically connected potential such that part of said time-varying current is
15 routed through said device when said time-varying current is applied through said
electrically conductive portion of said piping structure.

6. A petroleum well in accordance with claim 5, wherein said electrically
powered device comprises an electrically controllable valve adapted to control fluid
20 communication between one side of said packer and another side of said packer when
said packer is operably installed.

7. A petroleum well in accordance with claim 5, wherein said electrically
powered device comprises a sensor adapted to measure a physical quantity.

25

8. A petroleum well in accordance with claim 5, wherein said electrically
powered device comprises a modem adapted to send and receive communications along
said electrically conductive portion of piping structure.

5 9. A petroleum well in accordance with claim 5, wherein said electrically
powered device comprises a chemical injection module adapted to controllably inject a
substance into a flow stream.

10 10. A petroleum well in accordance with claim 5, wherein said electrically
powered device comprises an electrically controllable valve adapted to control fluid
communication between an exterior and an interior of a production tubing string.

15 11. A petroleum well in accordance with claim 5, wherein said electrically
powered device comprises an electrically controllable valve adapted to control fluid flow
within a production tube.

 12. A petroleum well in accordance with claim 5, wherein said piping
structure comprises a production tubing string of said well.

20 13. A petroleum well in accordance with claim 5, wherein said piping
structure comprises a well casing of said well.

 14. A petroleum well in accordance with claim 5, wherein said electrical
return comprises a well casing of said well.

25 15. A petroleum well in accordance with claim 5, wherein said electrical
return comprises at least a portion of an earthen ground.

5 16. A petroleum well in accordance with claim 5, further comprising a second
induction choke, said second induction choke being located about another part of said
electrically conductive portion of said piping structure and at a location along said piping
structure such that said electrical connection location for said time-varying current
source is located between said induction chokes.

10

 17. A petroleum well in accordance with claim 5, further comprising a second
packer.

15

 18. A petroleum well in accordance with claim 17, wherein said second
packer comprises an electrical insulator so that said electrically conductive portion of
said piping structure is not electrically connected to said electrical return at said second
packer when said second packer is operably installed.

20

 19. A petroleum well in accordance with claim 17, wherein said second
packer is part of said electrical return.

 20. A petroleum well in accordance with claim 5, wherein said packer is
located on said source-side of said induction choke.

25

 21. A petroleum well in accordance with claim 5, wherein said packer is
located on said electrical-return-side of said induction choke.

5

22. A method of operating a petroleum well comprising: providing an electrically powered packer in a petroleum well;

providing a piping structure in said well, said piping structure comprising an electrically conductive portion extending along at least part of said piping structure;

10 operably installing said electrically powered packer in said well, said electrically powered packer comprising an electrically powered device, such that said device is electrically connected to said electrically conductive portion of said piping structure when said well is operable for petroleum production;

15 operably installing an induction choke about part of said electrically conductive portion of said piping structure;

supplying time-varying current to said piping structure;

routing part of said time-varying current through said electrically powered device using said induction choke; and

producing petroleum products with said well.

20

23. A method in accordance with claim 22, further comprising the steps of:

measuring a physical quantity with said electrically powered device, wherein said electrically powered device comprises a sensor; and

varying a flow of petroleum products in said well based on said measurements.

25

24. A method in accordance with claim 22, further comprising the step of:

electrically controlling fluid communication between sections of said well using said packer, wherein said electrically powered device comprises an electrically controllable valve.

30

FIG. 1
(PRIOR ART)

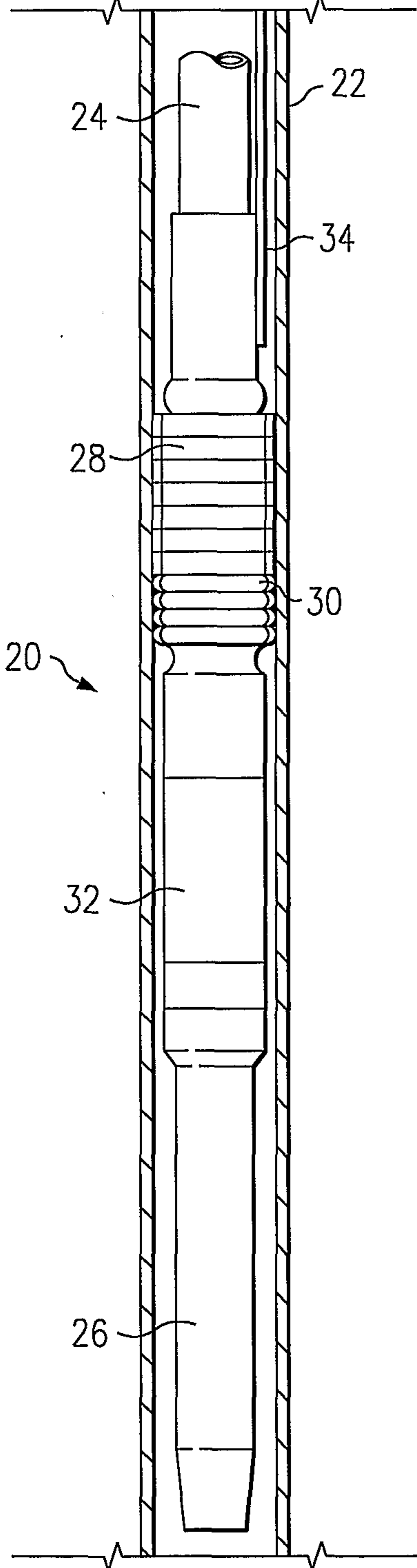

FIG. 4

