



INTERNATIONAL APPLICATION PUBLISHED UNDER THE PATENT COOPERATION TREATY (PCT)

<p>(51) International Patent Classification ⁷ : G01B 11/04, G01N 21/89</p>	<p>A1</p>	<p>(11) International Publication Number: WO 00/42381</p> <p>(43) International Publication Date: 20 July 2000 (20.07.00)</p>
<p>(21) International Application Number: PCT/SE99/02349</p> <p>(22) International Filing Date: 14 December 1999 (14.12.99)</p> <p>(30) Priority Data: 9900124-0 18 January 1999 (18.01.99) SE</p> <p>(71) Applicant (for all designated States except US): MYDATA AUTOMATION AB [SE/SE]; Adolfbergsvägen 11, S-168 66 Bromma (SE).</p> <p>(72) Inventors; and (75) Inventors/Applicants (for US only): BOSTRÖM, Gunnar [SE/SE]; Danavägen 21, S-168 53 Bromma (SE). JOHANNESON, Mattias [SE/SE]; Sörholmen 2, Landeryd, S-585 93 Linköping (SE). SANDGREN, Simon [SE/SE]; Fredhällsgatan 3, S-112 54 Stockholm (SE). ÅHLEN, Hans [SE/SE]; Birger Jarlsgatan 97, 5 tr., S-113 56 Stockholm (SE).</p> <p>(74) Agent: AWAPATENT AB; P.O. Box 45086, S-104 30 Stockholm (SE).</p>		<p>(81) Designated States: AE, AL, AM, AT, AT (Utility model), AU, AZ, BA, BB, BG, BR, BY, CA, CH, CN, CR, CU, CZ, CZ (Utility model), DE, DE (Utility model), DK, DK (Utility model), DM, EE, EE (Utility model), ES, FI, FI (Utility model), GB, GD, GE, GH, GM, HR, HU, ID, IL, IN, IS, JP, KE, KG, KP, KR, KZ, LC, LK, LR, LS, LT, LU, LV, MA, MD, MG, MK, MN, MW, MX, NO, NZ, PL, PT, RO, RU, SD, SE, SG, SI, SK, SK (Utility model), SL, TJ, TM, TR, TT, TZ, UA, UG, US, UZ, VN, YU, ZA, ZW, ARIPO patent (GH, GM, KE, LS, MW, SD, SL, SZ, TZ, UG, ZW), Eurasian patent (AM, AZ, BY, KG, KZ, MD, RU, TJ, TM), European patent (AT, BE, CH, CY, DE, DK, ES, FI, FR, GB, GR, IE, IT, LU, MC, NL, PT, SE), OAPI patent (BF, BJ, CF, CG, CI, CM, GA, GN, GW, ML, MR, NE, SN, TD, TG).</p> <p>Published <i>With international search report. Before the expiration of the time limit for amending the claims and to be republished in the event of the receipt of amendments.</i></p>

(54) Title: METHOD AND DEVICE FOR INSPECTING OBJECTS

(57) Abstract

This invention relates to a method for contactless inspection of objects on a substrate, by means of an inspection device during relative motion between the substrate and the inspection device. The method comprises the steps of: generating a first image comprising object height information by illuminating at least a portion of the substrate comprising one or more objects by means of first radiation means and imaging at least one of said one or more objects illuminated by said first radiation means onto a two-dimensional matrix sensor means having a portionwise addressable matrix of pixel elements; generating a second image comprising object area information by illuminating at least a portion of the substrate comprising one or more objects by means of second radiation means and imaging at least one of said one or more objects illuminated by said second radiation means onto said sensor means; extracting the object height information, by means of said sensor means, from said first image; and extracting the object area information, by means of said sensor means, from said second image. The invention also relates to a device for performing the above method.

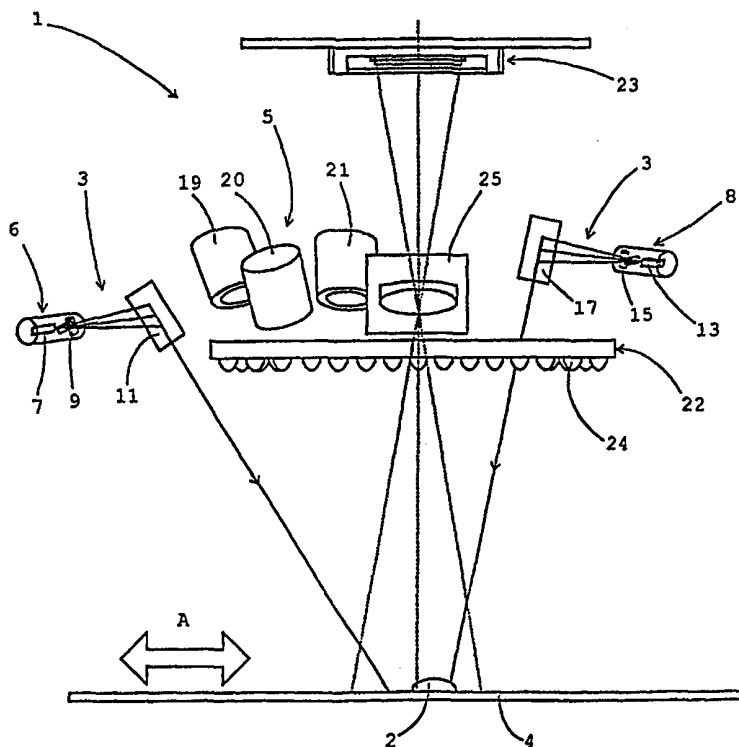

FOR THE PURPOSES OF INFORMATION ONLY

Codes used to identify States party to the PCT on the front pages of pamphlets publishing international applications under the PCT.

AL	Albania	ES	Spain	LS	Lesotho	SI	Slovenia
AM	Armenia	FI	Finland	LT	Lithuania	SK	Slovakia
AT	Austria	FR	France	LU	Luxembourg	SN	Senegal
AU	Australia	GA	Gabon	LV	Latvia	SZ	Swaziland
AZ	Azerbaijan	GB	United Kingdom	MC	Monaco	TD	Chad
BA	Bosnia and Herzegovina	GE	Georgia	MD	Republic of Moldova	TG	Togo
BB	Barbados	GH	Ghana	MG	Madagascar	TJ	Tajikistan
BE	Belgium	GN	Guinea	MK	The former Yugoslav Republic of Macedonia	TM	Turkmenistan
BF	Burkina Faso	GR	Greece	ML	Mali	TR	Turkey
BG	Bulgaria	HU	Hungary	MN	Mongolia	TT	Trinidad and Tobago
BJ	Benin	IE	Ireland	MR	Mauritania	UA	Ukraine
BR	Brazil	IL	Israel	MW	Malawi	UG	Uganda
BY	Belarus	IS	Iceland	MX	Mexico	US	United States of America
CA	Canada	IT	Italy	NE	Niger	UZ	Uzbekistan
CF	Central African Republic	JP	Japan	NL	Netherlands	VN	Viet Nam
CG	Congo	KE	Kenya	NO	Norway	YU	Yugoslavia
CH	Switzerland	KG	Kyrgyzstan	NZ	New Zealand	ZW	Zimbabwe
CI	Côte d'Ivoire	KP	Democratic People's Republic of Korea	PL	Poland		
CM	Cameroon	KR	Republic of Korea	PT	Portugal		
CN	China	KZ	Kazakistan	RO	Romania		
CU	Cuba	LC	Saint Lucia	RU	Russian Federation		
CZ	Czech Republic	LI	Liechtenstein	SD	Sudan		
DE	Germany	LK	Sri Lanka	SE	Sweden		
DK	Denmark	LR	Liberia	SG	Singapore		
EE	Estonia						

METHOD AND DEVICE FOR INSPECTING OBJECTSTechnical field

This invention generally relates to a method and device for contactless inspection of objects on a substrate, during relative motion between the substrate
5 and the inspection device.

Technical background

When arranging objects on a substrate geometrical and other properties of the objects are important for the performance of the resulting product. Consequently, it is
10 desired to be able to quickly and accurately perform an automatic inspection of these properties. Geometrical properties can for example be volume, position on the substrate, diameter, shape of outline, scratches, surface
15 roughness etc. Other properties can be, colour, etc. An automatic inspection of the properties is difficult to perform at high speed and high accuracy. For example, in the process of applying solder paste to the substrate, by dispensing it or the like, the properties of the
20 resulting solder paste deposit, e.g. volume and position, are important for the subsequent process steps and final yield.

Prior art is generally based on different imaging technologies such as 2-dimensional image processing,
25 pattern recognition and/or 3-dimensional optical triangulation, stereo photography, moiré methods and white-light interferometry.

For obtaining height information of an object, laser triangulation is often used, such as in an apparatus and
30 a method for inspecting solder printing as disclosed in US-5 134 665. A radiation source, generally a laser, is positioned at a lateral distance from a sensor and illuminating the object to be inspected from one

direction. The object is imaged onto the sensor via a radiation focusing element, such as refractive optics. The most common triangulation methods employ illumination with a single spot, a sheet-of-light or multistrip-light triangulation. The sensor views the object from another direction than the object is illuminated from and, thus, detects radiation reflected or reemitted from the object. Since the sensor is two-dimensional and since the positions of the radiation source and the sensor and the base plane for the object are known, it is possible to determine the height of the object by determining the direction of the radiation incident on the sensor.

Additionally, by scanning the whole object and determining a large number of height points or height profiles it is possible to determine an approximate volume of the object.

However, there are problems associated with prior art methods and devices. It is desired to combine speed and flexibility in one and the same arrangement. Generally, prior art methods and devices are dedicated to a single task and often they are not fast enough to comply with current and future demands.

In the above mentioned US-5 134 665 there is disclosed an apparatus for inspecting solder paste prints on a printed circuit board (PCB), which is one type of substrate. Other types of substrate are for example substrates for ball grid arrays (BGA), chip scale packages (CSP), quad flat packages (QFP), and flip-chips. The apparatus measures print deviation, film thickness and print pattern of solder paste printed on pads formed on the PCB. A height measurement is performed by means of a laser ray illuminating the PCB pointwise. By mutually moving the apparatus and the PCB the laser point is scanned over a single solder paste object. By scanning the object in orthogonal X- and Y-directions the projection of the object is obtained in the form of an X-direction and a Y-direction profile line showing both the

solder paste object and the underlying pad. By this known apparatus the positions and thicknesses of screen printed solder paste objects in relation to pre-printed pads are determinable. Drawbacks of this known apparatus are the limited use thereof. For example, neither accurate volume measurements nor accurate area measurements are performable, at least not reasonably fast, since this would require a vast number of scans in both directions.

Another solution dedicated for inspection of solder paste prints on a PCB is an apparatus manufactured by Philips called TriScan. The TriScan apparatus uses an advanced optical scanning system comprising a 20-side polygonal mirror rotating at a very high speed of up to 50 revolutions per second. A laser ray is projected onto the mirror and thereby a laser point is swept over the object at a rate of up to 1000 light sweeps per second. By advanced sets of mirrors the object is illuminated by said sweeps and reflected light is caught and guided to a sensor. While this apparatus enables several types of properties to be inspected at high speed it is complex and performs only measurements of height profiles as a basis for all determinations. The limitations to height profile measurements causes a limited accuracy. By measuring the profiles extremely closely, a certain improvement of accuracy may be obtained. However, this requires a high speed of measurement, which is difficult to achieve.

Summary of the invention

One object of this invention is to provide an inspection device for inspection of objects on a substrate during relative motion between the device and the substrate, and a method for inspection of objects on a substrate by means of such an inspection device, wherein said device and said method in an improved way combine inspection accuracy and a multiple task capability at high speed and low cost.

The object is achieved by aspects of the invention as defined in the enclosed claims.

In one aspect the present invention relates to a method for contactless inspection of objects on a substrate, by means of an inspection device during relative motion between the substrate and the inspection device. The method comprises the steps of:

- generating a first image comprising object height information by illuminating at least a portion of the substrate comprising one or more objects by means of first radiation means and imaging at least one of said one or more objects illuminated by said first radiation means onto a two-dimensional matrix sensor means having a portionwise addressable matrix of pixel elements;

- generating a second image comprising object area information by illuminating at least a portion of the substrate comprising one or more objects by means of second radiation means and imaging at least one of said one or more objects illuminated by said second radiation means onto said sensor means;

- extracting the object height information, by means of said sensor means, from said first image; and

- extracting the object area information, by means of said sensor means, from said second image.

In another aspect the invention relates to a device for performing the above method. The device comprises a two-dimensional matrix sensor means having a portionwise addressable matrix of pixel elements; a first radiation means; a second radiation means; and imaging means for imaging radiation originating from an object plane onto the sensor means. Said first radiation means is arranged for illuminating at least a portion of the substrate comprising one or more objects, when the substrate is in said object plane, said imaging means thereby generating a first image of at least one of said one or more objects, said first image comprising object height information. Said second radiation means is arranged for

illuminating at least a portion of the substrate comprising one or more objects, when the substrate is in said object plane, said imaging means thereby generating a second image of at least one of said one or more
5 obejects, said second image comprising object area information. Said sensor means comprises extraction means for extracting, from said first image, object height information, and for extracting, from said second image, object area information.

10 The generation of a first and a second image used for extracting object height information and object area information respectively in combination with employment of a matrix sensor means having a portionwise addressable matrix of pixel elements provides for an efficient and
15 flexible use of the generated image information for inspecting and determining properties of the one or more objects. Characteristic for such a sensor means is the matrix of pixel elements and the possibility to address, and thus read out, only a portion of the whole matrix at
20 a time. Portionwise is to be interpreted as at least one pixel at a time. This possibility is inventively employed to dedicate different combinations of pixel elements for different tasks. By generating two different images, by means of said first and second radiation means, the
25 multitask capability is inventively and efficiently used.

In comparison to the above described device and method of US-5 134 665 the present invention provides for both 2-dimensional and 3-dimensional inspection of
30 objects more or less simultaneously while moving the substrate and the device in relation to each other.

The expression "objects on the substrate" comprise many different possible objects, such as for example adhesive, flux, conductive adhesive, soldered seams, electronic components, soldered electronic components,
35 bumps, pins, and, particularly, deposits such as single or groups of solder paste or adhesive dots. The deposits may also comprise satellites, i.e. unwanted droplets of

dispensed solder paste, adhesive, conductive adhesive, etc., from the dispensing process.

By "radiation" is meant different types of light, such as visible light, infrared light, ultraviolet light, etc.; and by "frequency" is meant the frequency of the radiation waves. Instead of "frequency" the term "wavelength" could be equivalently used.

In an advantageous embodiment of the invention the sensor comprises on-chip signal processing capability. The signal processing consequently is performed on the same chip as the pixel elements are formed, which enhances the speed of the device by reducing the amount of output needed to be applied to external processing means.

In an advantageous embodiment of the invention said first and second images are alternately processed portion by portion, i.e. the images are processed portionwise and the processing jumps to and fro between the two images. This way of processing is close to parallel processing of the height and area information respectively. By employing a particularly advanced sensor means, in a further embodiment of the invention, it is even possible to perform a true parallel, that is simultaneous, processing of the area and height information respectively.

In yet further embodiments of the invention processing of the first and second images are additionally separated.

One aspect of separation is to separate the generation of the first and second images in time, thereby to minimise a possible difficulty of radiation associated with one of the images interfering with radiation associated with the other image on the sensor in a case where the first and second images overlap on the sensor surface. This time separation rather provides for a use of the same sensor area for sensing both images, which is advantageous in some cases.

Additionally, the possibility of illuminating the same area of the substrate without risking radiation interference in the object plane is enhanced.

Another aspect of separation is to separate the
5 first image from the second image by having different, that is geometrically separated, portions of the sensor means illuminated by the first and the second image respectively. As a result the risk of interference is substantially eliminated, and by using, in this way,
10 different sensor elements for the different images the total rate of images generated can be increased.

A further aspect of separation is to separate the first image from the second image by separating the radiation originating from said first and second
15 radiation means in a first and a second range of frequencies respectively, and by at least filtering the radiation impinging a first portion of the sensor means so that radiation within one of said first and second ranges of frequencies is passed and radiation within the
20 other one of said first and second ranges of frequencies is stopped. In addition to the above mentioned advantages of the enhanced separation, this aspect provides for a possibility to at least to some extent limit the area inspected on the substrate by limiting the dimensions of
25 said first portion. Optionally, two or more portions of the sensor means are covered by filters passing radiation within different frequency ranges.

Further objects and advantages of the present invention will be discussed below by means of exemplary em-
30 bodiments.

Brief description of the drawings

Fig. 1 is a schematic view of a device in accordance with an embodiment of the present invention;

35 Fig 2 is a schematic view of a range imaging technique employed by the device in Fig. 1;

Fig 3 is a schematic view of a line scan technique employed by the device in Fig. 1;

Fig 4a-b are schematic views of the radiation sensitive surface of a sensor means comprised in the device of Fig. 1;

Fig. 5 illustrates division of the radiation sensitive surface of the sensor means of Fig. 4 into subareas;

Fig. 6 illustrates a filter means divided into subareas.

Fig. 7 is a schematic perspective view of the sensor means, illustrating the construction thereof; and

Fig. 8 is a schematic perspective view of an enlarged detail of the sensor means of Fig. 7.

Detailed description of embodiments

A device according to an embodiment of the present invention is shown in Fig. 1. The device 1 is arranged above a substrate carrying an object 2 to be inspected. The device 1 and the object 2 are moving mutually, i.e. relative to each other, which is indicated by an arrow A. The object 2 could be of many different kinds as mentioned above. However, for the sake of simplicity of explanation, let us in the following assume that the object 2 is a solder paste deposit, which has been dispensed on the surface of the substrate, designated by 4. Generally, the inspected object 2 covered by the illuminated inspection area embraces a deposit comprising several dots but for reasons of clarity only a single dot 2 is shown in the drawings.

The device 1 comprises a first radiation means 3 for generating radiation of a first range of frequencies, or wavelengths, and a second radiation means 5 for generating radiation of a second range of frequencies. In this embodiment the first radiation means 3 comprises two similar radiation generators 6, 8, a first one 6 thereof comprising a first laser source 7, preferably a laser

diode, a first optically refractive means 9, preferably a pair of cylindrical lenses, and a first radiation directing means 11; and a second one 8 thereof similarly comprising a second laser source 13, a second optically refractive means 15, and a second radiation directing means 17. The radiation directing means 11, 17, which direct the generated radiation onto the substrate 4, are preferably comprised of flexible and lightweight mirrors. However, several alternatives are possible, such as prisms. The second radiation means 5 comprises a third, a fourth, and a fifth radiation generator 19, 20 and 21 respectively. In the illustrated preferred embodiment each of the third, fourth and fifth radiation generators 19, 20, 21 comprises a LED source, constituted by a set or group of LED (light emitting diode) elements, and refractive optics (not separately shown).

Additionally, the device 1 comprises a third radiation means 22 preferably constituted by a ringshaped radiation generator comprising a plurality of individual LEDs 24 and refractive optics (not separately shown).

The preferred choice of different types of radiation generators will be further explained below.

The device 1 further comprises sensor means or simply a sensor 23, arranged for detecting an image of the object 2 and imaging means 25 for creating said image by imaging the object 2 onto the sensor 23. Preferably, the sensor 23 is a two-dimensional matrix sensor having on-chip signal processing capability. As is shown in Figs. 7 and 8 the sensor 23 comprises a support 27 and an integrated circuit or chip 29 supported by the support 27. The chip 29 carries two parts 31, 33, a first one thereof constituting a radiation sensitive unit 31 and a second one thereof constituting a set of processing units 33, as also shown in Fig. 4b.

In this embodiment, said imaging means 25 is constituted by refractive optics, i.e. a lens system. The lens system 25 is arranged to optically forward radiation

originating from the object 2 to the sensor 23. In other words, the lens system 25 is arranged to image an object plane 32, as shown in Figs. 2 and 3, onto an image plane. The radiation originated from the object 2 is originally
5 generated by the radiation generators 6, 8, 19, 20, 21, 22 and reflected or reemitted by the object 2.

The radiation generators 6 and 8 are arranged at a distance from each other illuminating the object 2 from different, preferably opposite, directions and, in this
10 embodiment, as shown in Fig. 1, at different angles of incidence, i.e. angles to the object plane 32. There are at least three important properties associated with the choice of the angles of incidence. They are occlusion, vertical resolution and dynamic range of vertical
15 measurement. By choosing different angles it is possible to choose a different resolution and a different dynamic range for the inspection of different objects. Unfortunately, there will be some occlusion problems. On the other hand, if the angles are chosen to be equal,
20 which is an alternative embodiment, occlusion is substantially avoided, while on the other hand the resolution and dynamic range are fixed.

The third, fourth and fifth radiation generators 19-
21 are arranged at a distance from each other
25 illuminating the object 2 from different directions and preferably at different angles to the object plane 32. However, these radiation generators illuminate the same area of the object 2.

The third radiation means 22 is among other things
30 used for providing an even illumination of the whole substrate surface area imaged on the radiation sensitive unit 31. It provides an enhanced contrast between surfaces of the objects that are to be inspected and the closest background. Further, the third radiation means 22
35 is used for illuminating fiducials or reference markers on the substrate 4 for enabling aligning of the substrate

to the inspection device 1, and for calibrating the optics.

As shown in Fig. 4a and Fig. 4b, the radiation incident on the sensor 23, and more particularly on the radiation sensitive unit 31, is sensed by radiation sensing elements or pixels 35 arranged in a matrix on the surface of the radiation sensitive unit 31. The pixels 35 are, at least a subset thereof at a time, connectable to the set of processing units 33, where each processing unit 33 handles a single pixel 35. For example, in the sensor called MAPP2200 and manufactured by IVP, all pixels in one row at a time are handled in parallel by an array of processing units. Which row to be analysed is optional.

As another example, in a so-called APS, short for active pixel sensor, all pixel elements are individually addressable. The APS is also a matrix sensor where pixels are arranged on a chip. Some means for signal processing of the pixel output signals are integrated on-chip. A DSP (digital signal processor) is used for further processing of the output pixel signals. In a preferred embodiment of the APS, also the DSP is integrated on-chip. Typically, both sensor types are manufactured by means of Complementary Metal Oxide Semiconductor (CMOS) technology, though other methods of manufacture are optionally usable.

Each pixel element converts incident radiation into an electronic charge, which is then processed by on-chip hardware. Thus, the value of the charge is digitised, either by thresholding or by A/D-conversion.

Further, the on-chip hardware of the sensor 23, at least when it is of the MAPP2200 type, is capable of handling additional tasks necessary to perform in order to obtain useful image information. These tasks include data reduction and template matching or filtering operations which reduce noise or enhance object edges.

The sensor capabilities are inventively employed by the present device. Image information required for determining different properties of the object 2 is either area related information or height related information or both. The sensor 23, or more particularly the radiation sensitive unit 31, is dividable into different subareas each comprising a number of pixels, preferably one or more rows of pixels. The different subareas are dedicated for extraction of either area related or height related image information.

In this preferred embodiment the radiation sensitive unit 31 is divided into first and second subareas 37, 39 for extracting height information and a third subarea 41 for extracting area information, as shown in Fig. 5. For reasons to be described below the division of the radiation sensitive unit 31 is preferably done physically as is shown in Fig. 6. A filter means or filter layer 42 is arranged on the surface of the radiation sensitive unit 31. The filter means 42 is provided with a first narrow all pass portion 34, and a second portion 36 passing said first range of frequencies radiated from the first radiation means 3, and stopping said second range of frequencies, radiated from the second radiation means 5. Consequently, for a full use of this filter means 42 the first and second frequency ranges are spaced apart, i.e. one of the separation aspects mentioned above in the summary of the invention is employed in this embodiment, which is to be further discussed below.

The first and second radiation means 3, 5 are adapted for providing the sensor 23 with first and second images respectively, the first image being generated so as to substantially comprise height information and the second image being generated so as to substantially comprise area information. In order to obtain these different images, on one hand the radiation generated by said first means 3 is laser radiation of said first frequency range and line, or sheet, shaped when reaching

the object plane 32. This is also called sheet-of-light illumination. On the other hand, the radiation generated by said second radiation means 5 is LED radiation having a less limited shape when reaching the object plane 32.

5 The sheet-of-light illumination is illustrated in Fig. 2, and the LED illumination is illustrated in Fig. 3. For sake of clarity, in both figures, the radiation of a single generator is shown.

The first and second radiation generators 6, 8 are arranged so as to illuminate a first portion of the substrate 4 and the third to fifth radiation generators 19, 20 and 21 are arranged so as to illuminate a second portion of the substrate 4. The reason for separating the illuminated first and second portions is to prevent radiation interference negatively affecting the extraction of height information and area information respectively. However, alternative embodiments, such as the one providing a time separation as mentioned above, enable illumination of the same portions. The separation is enhanced by separating the first and second frequency ranges in frequency combined with using the filter 42, while alternative embodiments employ overlapping frequency ranges.

10
15
20

The choice of different types of radiation generators 6, 8 and 19-21 respectively is dependent on the construction of the sensor 23, the division of the radiation sensitive unit 31 and the different types of image information extracted. Since the height of the object is determined by triangulation, height profiles of the object 2 are generated by means of the sensor 23, requiring the used subareas 37, 39 to be large enough, typically several adjacent pixel rows are employed, to encompass such profiles. Each sheet-of-light generates one profile. Consequently, as shown in Fig. 5, in this embodiment two profiles 38 and 40 respectively are generated. As is illustrated, since the illuminated areas on the substrate 4 are different for the first and second

25
30
35

radiation generator 6 and 8 respectively, the profiles 38, 40 are associated with different objects or different portions of a single object. Typically, a few profiles per object 2 are enough to obtain sufficient height
5 information, in combination with the area information, to be able to determine requested properties.

The area information is achieved by line scanning, which means that the object 2 is scanned line by line, the lines being adjacent. Typically, one line corresponds
10 to a single pixel row on the radiation sensitive unit 31, all pixels of the row being processed in parallel. In order to achieve such a thin line of radiation incident on the sensitive unit 31 it would be natural to illuminate the object in a correspondingly narrow area
15 using a laser source. However, this has proven difficult due to speckle noise induced by local interference in the object 2. The problem of speckle noise is eliminated by using non-coherent radiation such as that generated by the LEDs, which accordingly is preferred. On the other
20 hand, when using LEDs, difficulties may arise in limiting the illuminated area. By rather limiting the subarea 41 used for receiving area information on the sensor 23 to, for example, a single row of pixels the later problem is avoided. Still, however, the area in the object plane 32
25 illuminated by the LED sources of the third to fifth radiation generators 19-21 is limited by means of refractive optics in order to separate it from the areas illuminated by the laser sources 7, 13 of the first and second radiation generators 6 and 8 respectively. A
30 further object of limiting the area by means of the refractive optics is to achieve a higher intensity of the radiation within the illuminated area of the substrate 4. The above described spectral filter is preferably employed for enhancing the separation.

35 For obtaining the height information, it is possible to achieve a good resolution even if the width of the sheet-of-light or laser line amounts to a few rows of

pixels, such as 3-5 rows. Thereby the impact of the speckle noise is substantially decreased, which enables the use of the laser sources 7, 13.

Further, each of the first and second radiation
5 generators 6, 8 generates an individual laser line which is imaged on a separate portion of the radiation sensitive unit, i.e. the first and second subareas 37, 39 respectively, as is shown in Fig. 5. Consequently, different resolutions, i.e. number of pixel rows, may be
10 employed.

Thus, while moving the object 2 in relation to the device 1 the row of pixels forming the subarea 41 is consecutively sampled and processed for extracting object area information line by line. This processing is
15 combined with processing of the height information collected by correspondingly sampling the rows of pixels of the other subareas 37, 39. Preferably, the area information and the height information are alternately extracted in order to use the full capacity of the
20 sensor. The alternating determinations are principally run in parallel by chopping the jobs, thus executing alternately portions of a whole line and area respectively. Thereby, a high speed of movement is enabled while keeping the accuracy at a high level.

25 In order to enhance the results at a high speed movement the radiation generators 6, 8, 19, 20, 21 are preferably pulsed, or the radiation emitted is pulsed, thereby to minimise blurring caused by the movement while the radiation generators are emitting radiation.

30 As is evident from the above, the sensor 23 generates digital output signals. These output signals are communicated to a control means, such as a CPU (central processing unit) (not shown), further processing said output signals. The output signals comprise height
35 information output and area information output used by the control means to determine different properties of the object 2. Further, the control means is used by a

user to program the sensor 23. The programming may
comprise for example defining the different subareas 37,
39, 41 and initiating different image processing
capabilities thereof such as those sharpening object
5 edges. Due to the on-chip hardwired and/or programmed
signal processing capabilities of the sensor 23, the
amounts of data exchanged between the sensor 23 and the
control means are reduced, enabling a faster object
inspection process. When using an advanced sensor such as
10 MAPP2200 the on-chip capabilities are complex enough to
assert that the signal processing performed on-chip is an
image processing.

The present invention is provided for inspecting
objects on a substrate, and particularly solder paste
15 deposits 2 dispensed thereon. A substrate arranged for
surface mounting components is provided with printed
platforms or pads for receipt of component connection
terminals. The components are connected to the pads by
soldering. The solder paste is pre-applied to the pads by
20 some general method, like screen printing or dispensing.
In order for the subsequent mounting and soldering of the
components to be successful it is important that the
solder paste deposit, below simply referred to as
deposit, is correctly shaped and positioned, and that no
25 solder paste satellites are generated.

Due to the small dimensions of the deposit,
typically in the order of fractions of a millimetre,
accurate measurements of high resolution is required of
the inspection device. Due to quality requirements it is
30 desired that every deposit on a substrate is inspected
after being dispensed. Further, the dispensing rate is
high and continuously increasing and consequently it is
desired to be able to perform the inspection at a high
rate as well. Additionally, it is desired to be able to
35 determine different properties, such as those mentioned
above.

By the present invention a high rate is enabled by the inventive use of the sensor 23. As to the different properties desired to determine, the area information is obtained line by line as described. The above mentioned
5 MAPP2200 sensor is able to generate adjacent area lines corrected for occasional erroneous pixels and having distinct limits between the deposit and the surrounding pad or pads. The lines are output to the CPU which calculates the very area of the deposit. Similarly, a
10 number of height profiles also pre-processed on-chip, or, alternatively, in another way either internal or external of the device 1, are output to the CPU. The area and height outputs are position associated by the sensor, and thereby the CPU is able to combine the height and area
15 information related to the same deposit for determining volume etc. A future even more advanced sensor will most likely be able to perform many further calculations on-chip and it is likely to believe that the sensor will contain one processing unit per pixel instead of a number
20 of processing units corresponding to the number of pixels in a row.

The device 1 adapts the illumination, by adapting the emitted radiation of the radiation generators 6, 8, 19-22, according to properties of the present objects 2
25 under inspection in order to facilitate the signal processing and enable a reliable and accurate information extraction. A typical goal of the adaptive illumination is to emphasise the contrast between an object and its neighbouring background. Adaptable parameters are at
30 least the following:

- * The intensity of the radiation is tuned in order to obtain high enough levels of contrast.

- * The angle of incidence towards the objects is usable in order to emphasise the contrasts.

- * The polarisation of the radiation is efficiently usable for reducing for example glitter from bright
35 objects. For this purpose one polariser is provided

between the radiation generator 6, 8, 19-22 and the substrate 4, or more particularly the object or objects thereon. Additionally, another polariser is provided in front of the sensor 23, the orientation thereof being perpendicular to the first mentioned polariser. As a result all reflections which are direct, i.e. which do not change the polarisation caused by the first polariser, is then blocked by the second polariser. On the other hand, the radiation which is spread in the surface of the object 2 is given a randomised contribution of polarisation and thereby reaches the radiation sensitive unit 31.

* The frequency/wavelength of the radiation.

The device of the present invention is implementable as a stand-alone apparatus, or as a part of a machine for dispensing solder paste, screen printing, mounting components, etc.

Above some embodiments of the present invention has been described. This should be seen as merely a non-limiting example. Many additional modifications will be possible within the scope of the invention as defined by the claims.

CLAIMS

1. A method for contactless inspection of objects on a substrate, by means of an inspection device during
5 relative motion between the substrate and the inspection device, c h a r a c t e r i s e d by the steps of:
- generating a first image comprising object height information by illuminating at least a portion of the substrate comprising one or more objects by means of
10 first radiation means and imaging at least one of said one or more objects illuminated by said first radiation means onto a two-dimensional matrix sensor means having a portionwise addressable matrix of pixel elements;
 - generating a second image comprising object area
15 information by illuminating at least a portion of the substrate comprising one or more objects by means of second radiation means and imaging at least one of said one or more objects illuminated by said second radiation means onto said sensor means;
 - 20 - extracting the object height information, by means of said sensor means, from said first image; and
 - extracting the object area information, by means of said sensor means, from said second image.
2. A method according to claim 1, c h a r a c -
25 t e r i s e d in that the step of generating a first image is separated in time from the step of generating a second image.
3. A method according to claim 1 or 2, c h a r a c -
t e r i s e d in the step of separating the first image
30 from the second image by imaging the first and second images respectively onto separate portions of said sensor means.
4. A method according to claim 1, 2, or 3,
c h a r a c t e r i s e d in the step of separating the
35 first image from the second image by illuminating different portions of the substrate with said first and second radiation means respectively.

5. A method according to any one of the preceding claims, characterised in the step of separating the first image from the second image by separating the radiation originating from said first and second radiation means in a first and a second range of frequencies respectively, and by at least filtering the radiation impinging a first portion of the sensor means so that radiation within one of said first and second ranges of frequencies is passed and radiation within the other one of said first and second ranges of frequencies is stopped.

6. A method according to any one of the preceding claims, characterised in the step of using said area and height information for calculating object volume.

7. A method according to any one of the preceding claims, characterised in the step of using said area information for calculating object position.

8. A method according to any one of the preceding claims, characterised in the step of using said area information for calculating shape of object outline.

9. A method according to any one of the preceding claims, characterised in the step of using said area information for calculating object diameter.

10. A method according to any one of the preceding claims, characterised in that at least some signal processing is performed on-chip.

11. A method according to claim 10, characterised in the step of performing said area and height information extractions on-chip.

12. A method according to any one of the preceding claims, characterised in the step of alternately processing said first and said second image for obtaining said height and area information respectively.

13. A method according to anyone of claims 1-11, characterised in the step of processing said first and said second image in parallel for obtaining said height and area information respectively.

5 14. A method according to any one of the preceding claims, characterised in that radiation the substrate is illuminated by said first radiation means in the form of a sheet-of-light illumination.

10 15. A method according to any one of the preceding claims characterised in that said step of extracting area information is performed by line scanning.

15 16. A method according to any one of the preceding claims characterised in that said step of extracting height information is performed by triangulation.

20 17. A method according to any one of the preceding claims characterised by adaptively tuning at least one of said first and second radiation means in response to changing conditions.

18. A device for inspecting objects on a substrate during relative motion between the substrate and the inspection device, characterised by:

- 25 - a two-dimensional matrix sensor means having a portionwise addressable matrix of pixel elements;
 - a first radiation means;
 - a second radiation means; and
 - imaging means for imaging radiation originating from an object plane onto the sensor means;
- 30 said first radiation means being arranged for illuminating at least a portion of the substrate comprising one or more objects, when the substrate is in said object plane, said imaging means thereby generating a first image of at least one of said one or more
- 35 objects, said first image comprising object height information;

said second radiation means being arranged for illuminating at least a portion of the substrate comprising one or more objects, when the substrate is in said object plane, said imaging means thereby generating
5 a second image of at least one of said one or more objects, said second image comprising object area information;

said sensor means comprising extraction means for extracting, from said first image, object height
10 information, and for extracting, from said second image, object area information.

19. A device according to claim 18, c h a r a c -
t e r i s e d in that the sensor comprises on-chip signal processing capability.

15 20. A device according to claim 19, c h a r a c -
t e r i s e d in that said on-chip signal processing capability is provided by at least said extraction means.

21. A device according to claim 20, c h a r a c -
t e r i s e d in that said on-chip signal processing
20 capability is further provided by on-chip means for calculating one or more object properties by means of at least either of said object height information and said object area information.

22. A device according to any one of claims 18-21,
25 c h a r a c t e r i s e d in that the generation of the first image is separated in time from the generation of the second image.

23. A device according to any one of claims 18-22,
c h a r a c t e r i s e d in that the sensor is provided
30 with at least a first portion for receiving the first image and a second portion, separate from the first portion, for receiving the second image.

24. A device according to any one of claims 18-23,
c h a r a c t e r i s e d in that the first radiation
35 means is provided for generating radiation within a first range of frequencies, that the second radiation means is provided for generating radiation within a second range

of frequencies and that the device further comprises at least a first filter means passing radiation within one of said first and second ranges of frequencies and stopping radiation within the other one of said first and second ranges of frequencies, said filter means covering a first portion of said sensor means.

25. A device according to claim 18-24, characterised in that it is arranged for extracting the object area information by means of line scanning .

10 26. A device according to any one of claims 18-25, characterised by said first radiation means comprising a laser generating the radiation by way of a sheet-of-light.

15 27. A device according to any one of claims 18-25, characterised by said radiation means comprising light emitting diodes (LEDs).

28. A device according to any one of claims 18-27, characterised in that each pixel element is individually addressable.

20 29. A device according to any one of claims 18-28, characterised in that at least one of said radiation means is adaptively tuneable.

25 30. A device according to any one of claims 18-29, characterised by a third radiation means for illuminating an area of the substrate corresponding to the whole matrix of pixel elements.

30 31. A device according to claim 30, characterised in that at least one of said first, second and third radiation means is provided with a first polariser and that at least a part of the sensor is provided with a second polariser arranged perpendicular to the first polariser.

35 32. Use of a device according to any one of claims 18-31 for measuring the volume of deposits on a substrate.

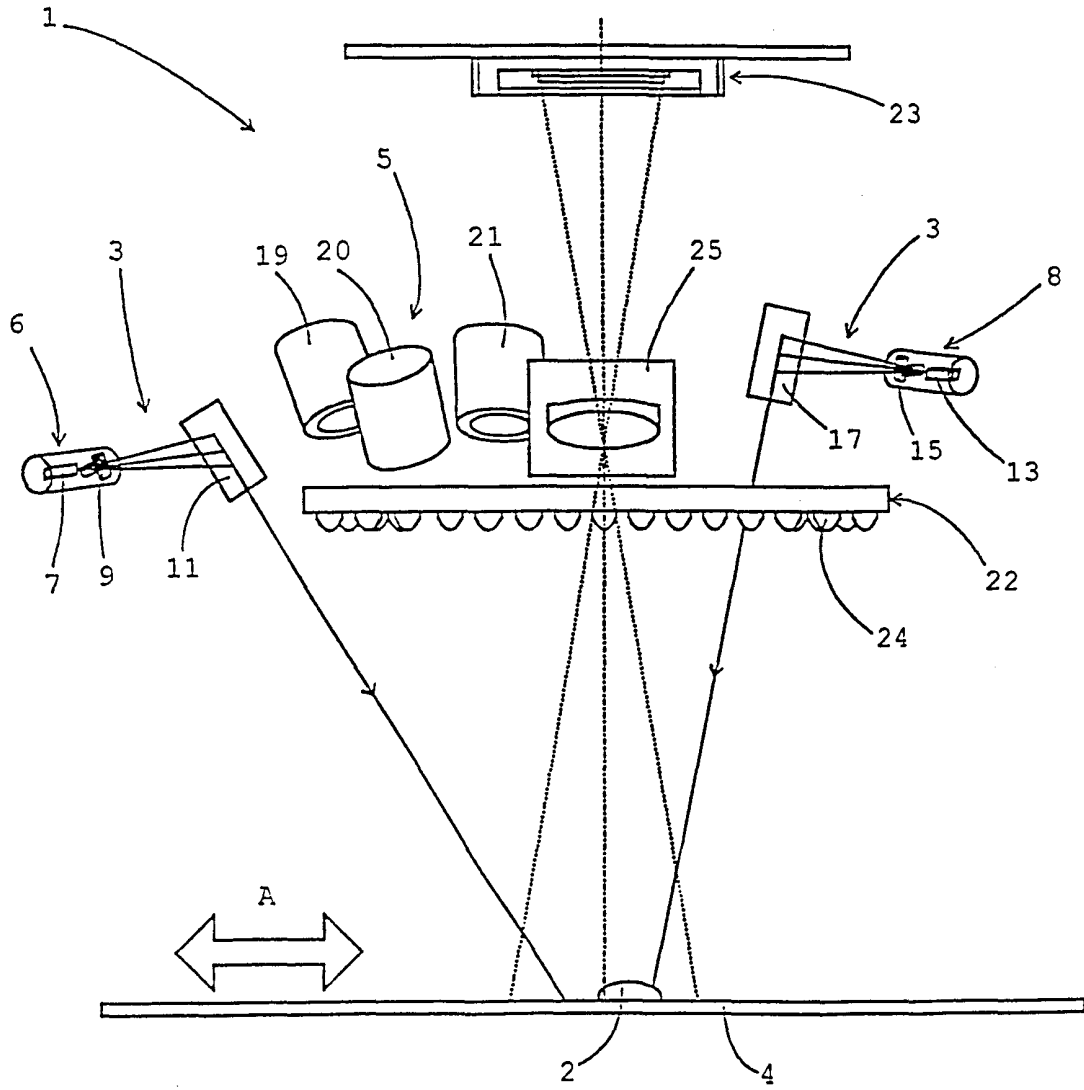

Fig. 1

2/5

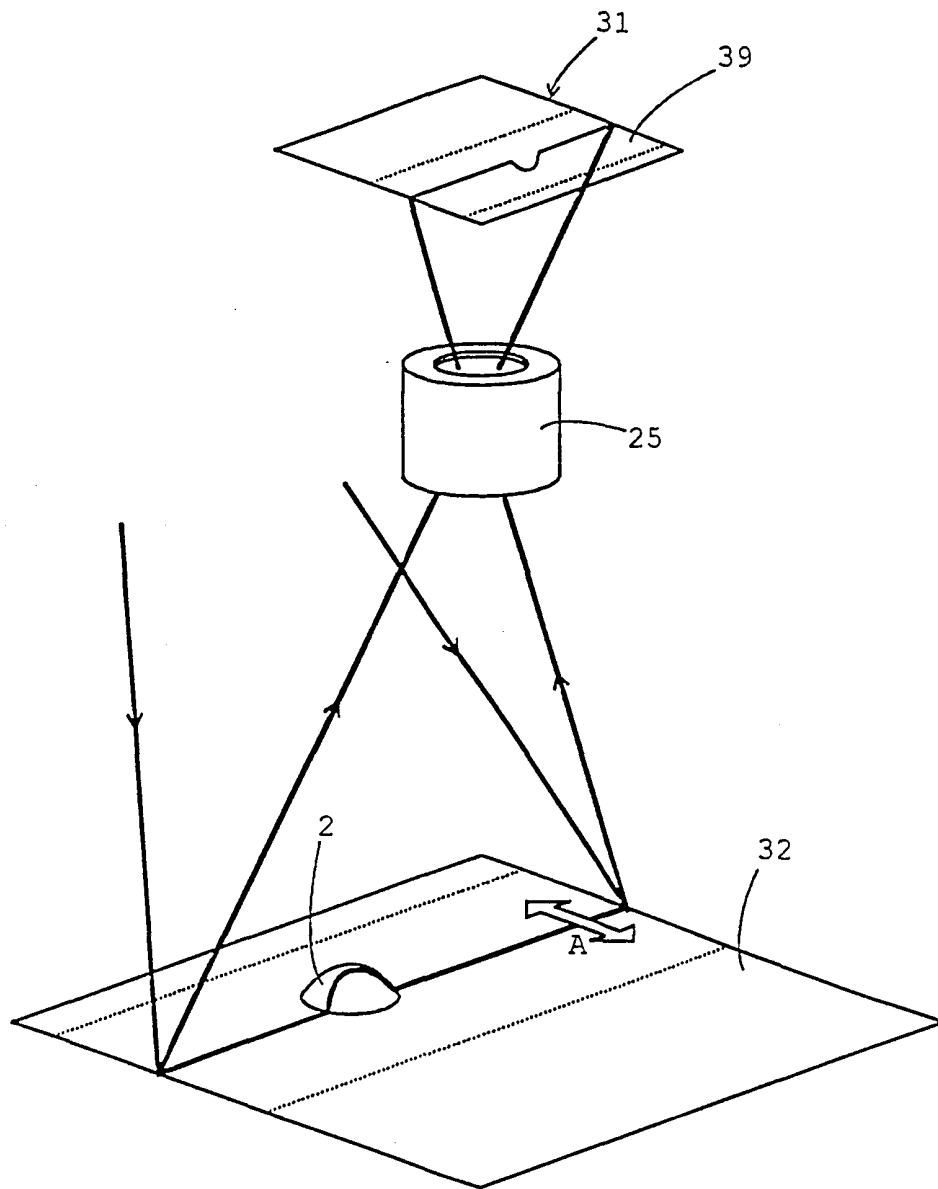

Fig. 2

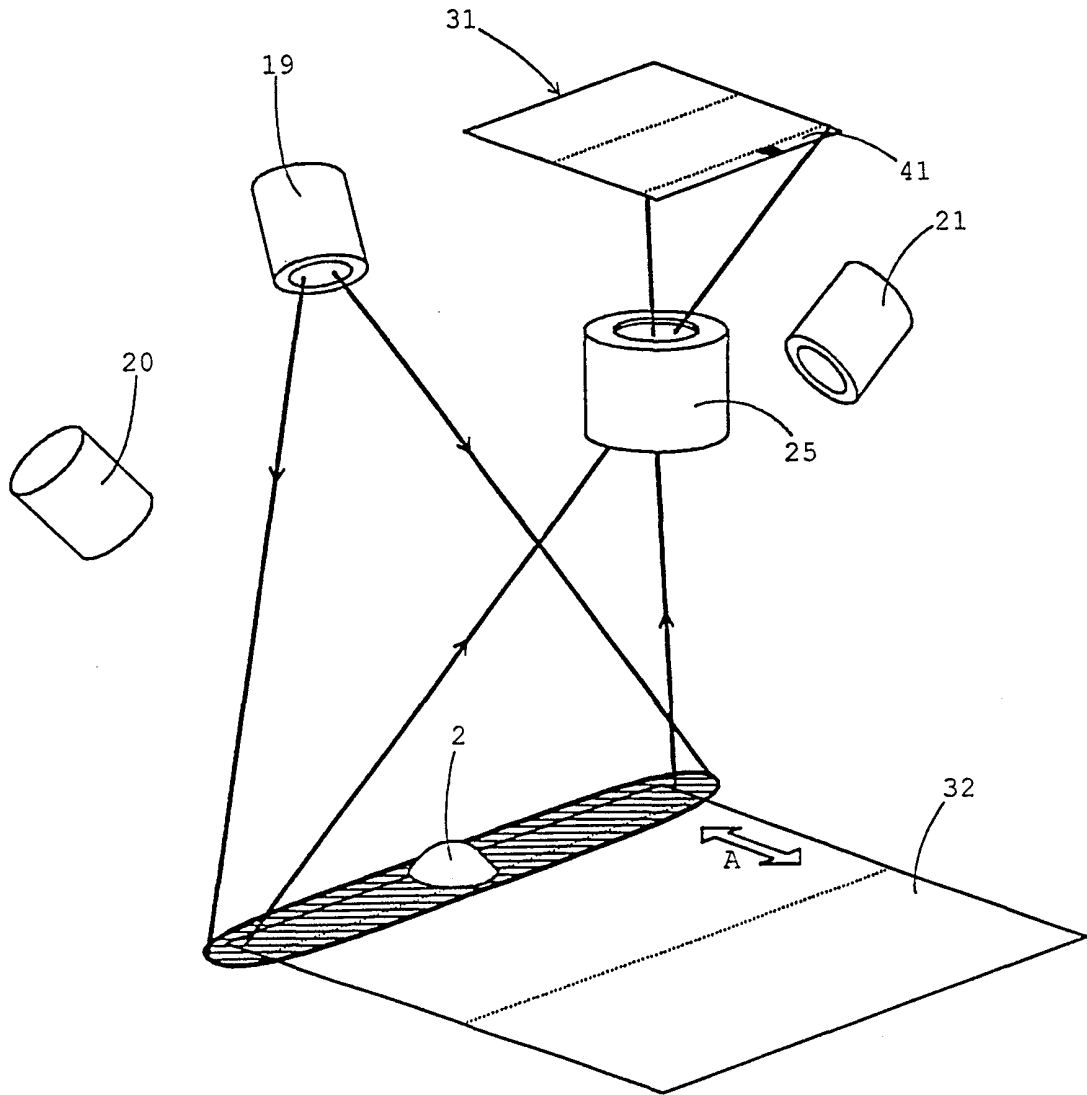
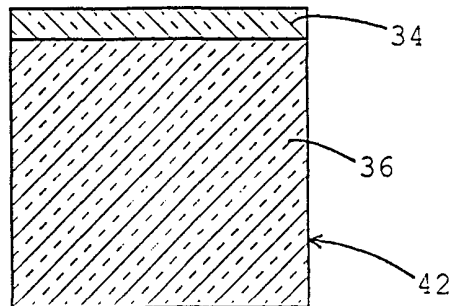
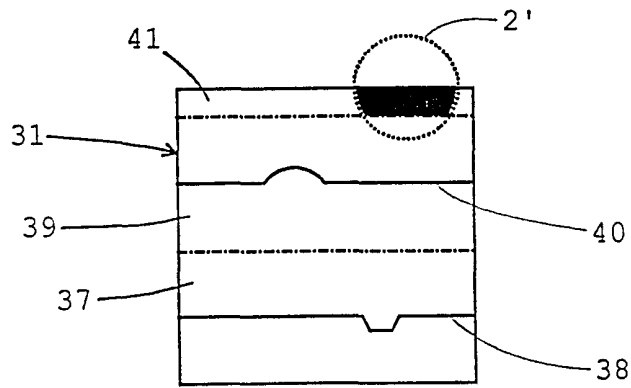
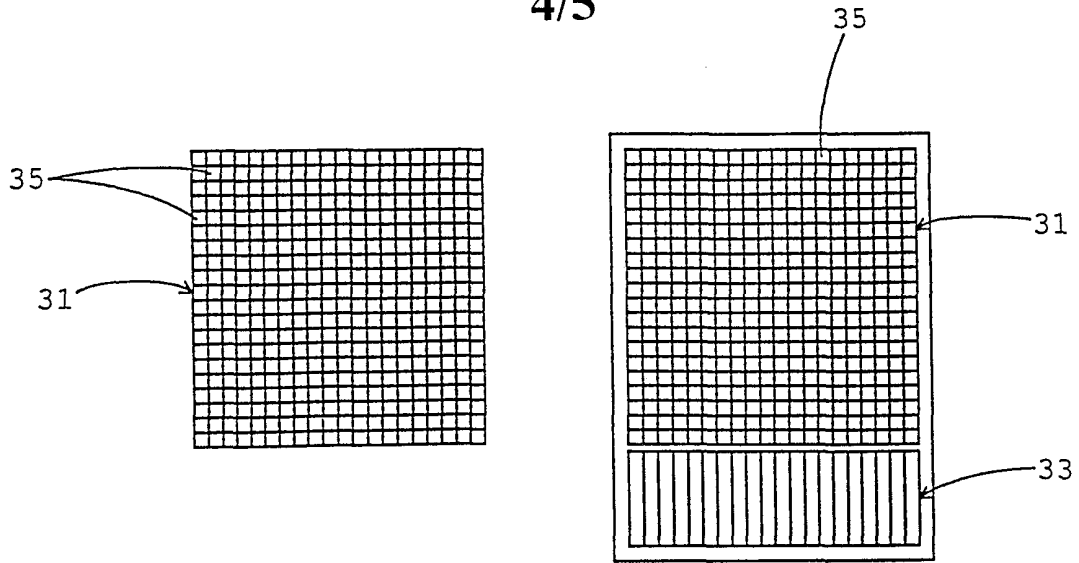

Fig. 3

4/5



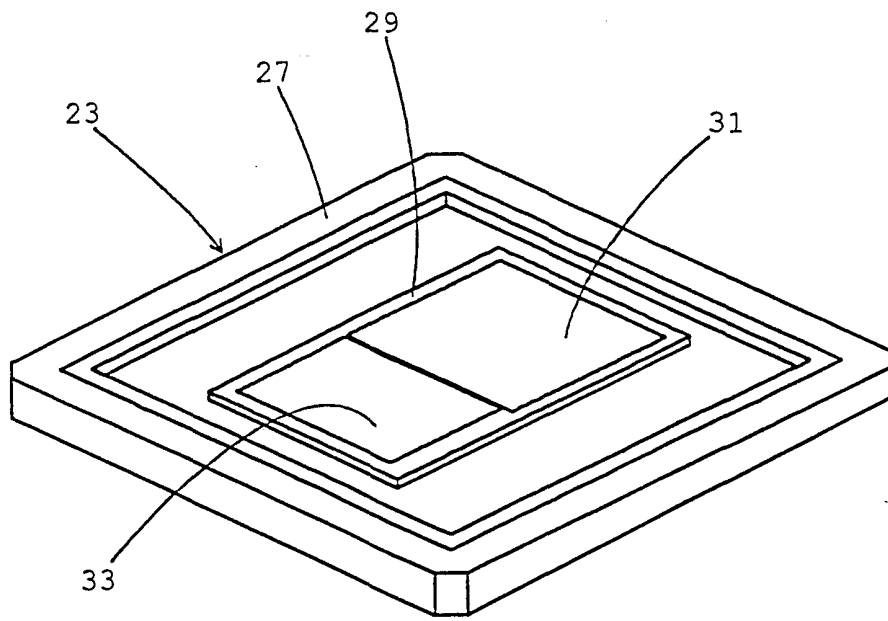

Fig. 7

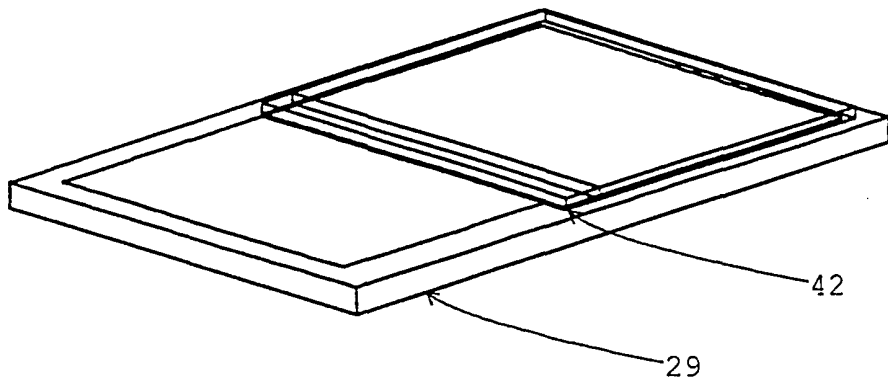

Fig. 8

INTERNATIONAL SEARCH REPORT

International application No.

PCT/SE 99/02349

A. CLASSIFICATION OF SUBJECT MATTER		
IPC7: G01B 11/04, G01N 21/89 According to International Patent Classification (IPC) or to both national classification and IPC		
B. FIELDS SEARCHED		
Minimum documentation searched (classification system followed by classification symbols)		
IPC7: G01N, G01B, G06T		
Documentation searched other than minimum documentation to the extent that such documents are included in the fields searched		
SE,DK,FI,NO classes as above		
Electronic data base consulted during the international search (name of data base and, where practicable, search terms used)		
C. DOCUMENTS CONSIDERED TO BE RELEVANT		
Category*	Citation of document, with indication, where appropriate, of the relevant passages	Relevant to claim No.
D,A	US 5134665 A (N. JYOKO), 28 July 1992 (28.07.92), figure 1, abstract --	1-32
A	1988 Conference on Precision Electromagnetic Measurements, Tsukuba, Ibaraki, Japan, H. Ikeda: "Surface mounted parts inspection and correction for PC board warpage", pages 237-238, see the whole document --	1-32
A	US 5162866 A (H. TOMIYA ET AL.), 19 November 1992 (19.11.92), figure 1, abstract --	1-32
E	US 5912732 A (A. SEKINE), 15 June 1999 (15.06.99) --	1-32
<input checked="" type="checkbox"/> Further documents are listed in the continuation of Box C. <input checked="" type="checkbox"/> See patent family annex.		
* Special categories of cited documents: "A" document defining the general state of the art which is not considered to be of particular relevance "E" earlier document but published on or after the international filing date "L" document which may throw doubts on priority claim(s) or which is cited to establish the publication date of another citation or other special reason (as specified) "O" document referring to an oral disclosure, use, exhibition or other means "P" document published prior to the international filing date but later than the priority date claimed		"T" later document published after the international filing date or priority date and not in conflict with the application but cited to understand the principle or theory underlying the invention "X" document of particular relevance: the claimed invention cannot be considered novel or cannot be considered to involve an inventive step when the document is taken alone. "Y" document of particular relevance: the claimed invention cannot be considered to involve an inventive step when the document is combined with one or more other such documents, such combination being obvious to a person skilled in the art "&" document member of the same patent family
Date of the actual completion of the international search		Date of mailing of the international search report
9 May 2000		12 -05- 2000
Name and mailing address of the ISA/ Swedish Patent Office Box 5055, S-102 42 STOCKHOLM Facsimile No. +46 8 666 02 86		Authorized officer Patrik Blidefalk/AE Telephone No. +46 8 782 25 00

INTERNATIONAL SEARCH REPORT

International application No.

PCT/SE 99/02349

C (Continuation). DOCUMENTS CONSIDERED TO BE RELEVANT		
Category*	Citation of document, with indication, where appropriate, of the relevant passages	Relevant to claim No.
E	EP 0898163 A1 (FRAUNHOFER-GESELLSCHAFT ZUR FÖRDERUNG DER ANGEWANDTEN FORSCHUNG E.V. ET AL.), 24 February 1999 (24.02.99) -- -----	

INTERNATIONAL SEARCH REPORT
Information on patent family members

International application No.
PCT/SE 99/02349

Patent document cited in search report	Publication date	Patent family member(s)	Publication date
US 5134665 A	28/07/92	JP 2691789 B JP 3257354 A	17/12/97 15/11/91
US 5162866 A	19/11/92	JP 2890578 B JP 3195042 A	17/05/99 26/08/91
US 5912732 A	15/06/99	JP 10019792 A JP 10030989 A JP 10038813 A	23/01/98 03/02/98 13/02/98
EP 0898163 A1	24/02/99	WO 9910730 A	04/03/99