

(No Model.)

F. QUEISZER.
ATTACHMENT FOR VEHICLE POLES.

No. 524,837.

Patented Aug. 21, 1894.

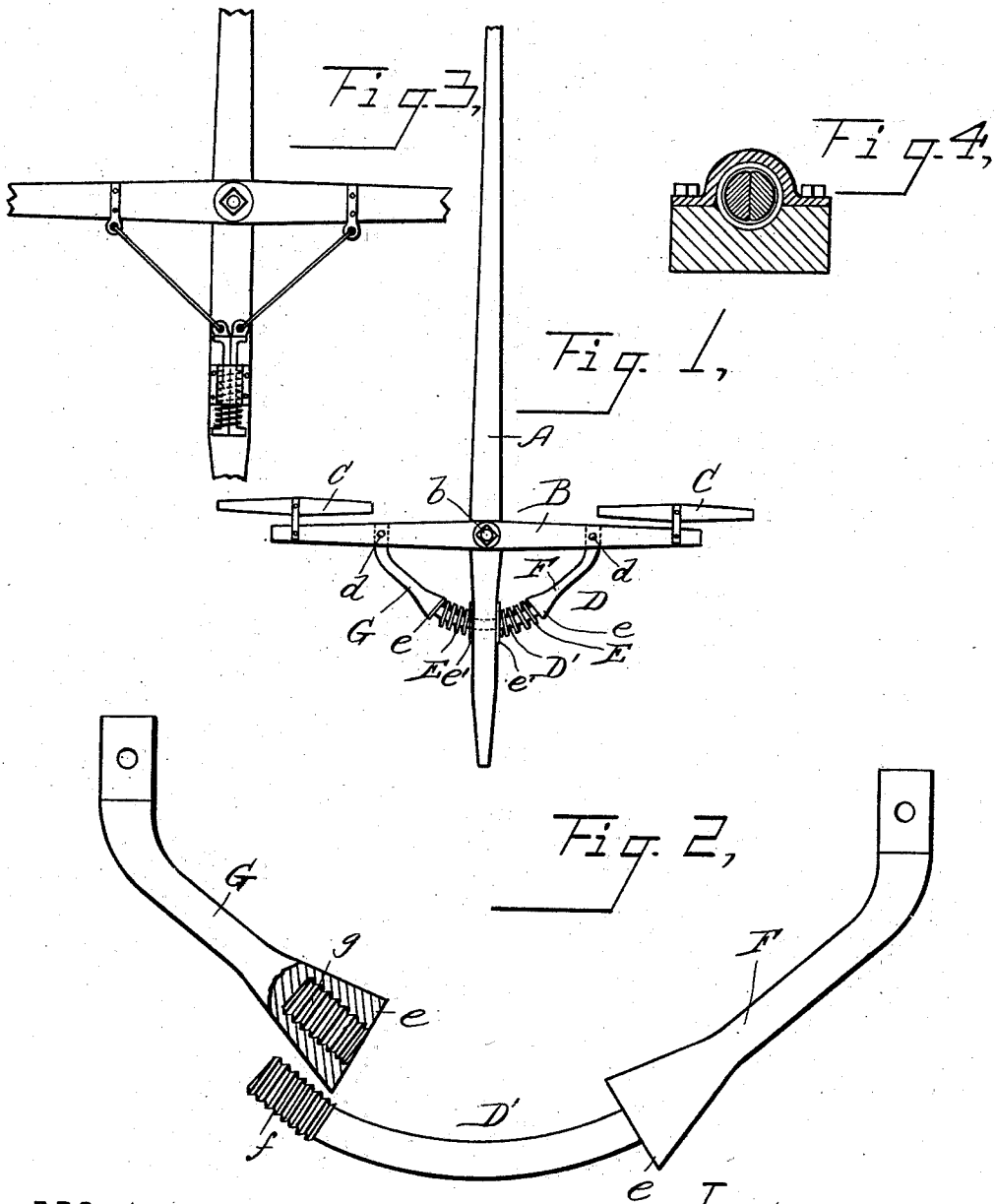

Witnesses,
J. Lumberger
E. N. Smith

Inventor
Frank Queiszer
By *John C. Miles*
Attorney

UNITED STATES PATENT OFFICE.

FRANK QUEISZER, OF MILWAUKEE, WISCONSIN.

ATTACHMENT FOR VEHICLE-POLES.

SPECIFICATION forming part of Letters Patent No. 524,837, dated August 21, 1894.

Application filed March 24, 1894. Serial No. 505,020. (No model.)

To all whom it may concern:

Be it known that I, FRANK QUEISZER, a citizen of the United States, residing at Milwaukee, in the county of Milwaukee, State of Wisconsin, have invented a certain new and useful Improvement in Attachments for Vehicle-Poles; and I declare the following to be a full, clear, and exact description of the invention, such as will enable others skilled in the art to which it pertains to make and use the same, reference being had to the accompanying drawings, which form a part of this specification.

My invention relates to new and useful improvements in the construction of attachments for vehicle poles, and relates more particularly to devices for maintaining the evener or double-tree in its proper relative position with respect to the pole or tongue, and my said invention consists in the matters hereinafter described and pointed out in the appended claims.

In the accompanying drawings illustrating my invention, Figure 1 is a plan view of a vehicle pole with the evener and the whiffle-trees attached thereto, and provided with my improved device. Fig. 2 is a detail view of my improvement, showing the parts of the same detached.

Referring by letter to said drawings, A designates the vehicle pole, B the evener, and C the whiffle-trees, which may be of any ordinary or desired construction. It has been common heretofore, to provide various forms of devices for normally retaining the evener in proper position with respect to the pole, so as to prevent undue movement of the same about its pivotal connection with the pole, and for this purpose it has been common to connect chains or straps with the evener upon opposite sides of the pole, and extend said chains or straps back to the axle or other stationary part of the vehicle, so as to limit the movement of the evener in either direction upon its pivotal support. It is the object of my present invention, to provide a suitable device for engagement with the evener and with the tongue of the vehicle for permitting a proper amount of movement of the evener with respect to the tongue, but for limiting such movement, and at the same time for returning the evener to its normal position at

right angles to the pole or tongue. To this end, I provide a suitable arm or brace D, which is secured by bolts $d d$ to the evener, 55 at opposite sides of the pole or tongue and which is arranged to extend rearwardly substantially in the manner shown in Fig. 1, in the form of an arch. The central part D' of this brace D is conveniently passed through 60 an aperture in the pole or tongue in the manner shown, and this part of the brace is formed on the arc of a circle concentric with the pivotal connection b between the pole and the evener. By this arrangement as the 65 evener moves upon its pivotal support b , the concentric central part D' of the brace D is free to play back and forth through the aperture in the pole or tongue in an obvious manner. Upon said central part D' of the 70 brace, I prefer to provide suitable springs E E arranged to bear at their outer ends against shoulders $e e$ formed on said brace, and at their inner ends against suitable metallic washers $e' e'$ at the sides of the pole. 75

It follows from this construction that the springs E E while permitting a considerable degree of movement of the evener upon the pole, will serve to automatically return the evener to its normal position at right angles 80 to the pole, and furthermore, while permitting a necessary degree of movement, the shoulders $e e$ will limit the movement of the evener at the point where the limit of compression of the springs between said shoulder and the 85 tongue or pole is reached.

As shown more particularly in Fig. 2 of the drawings, I find it convenient in practice to make the brace D in two sections, F and G, the former of which is provided at one end 90 with a screw threaded shank, f , and the latter with a screw-threaded socket g , the joint being conveniently formed adjacent to one of the shoulders E E. By this construction, the section F may be adjusted in position, the 95 central part D' being passed through the aperture in the pole or tongue, and the springs adjusted in position and the other part G then screwed onto the end of the part F, in an obvious manner, when the two ends of the brace 100 may be readily secured to opposite sides of the evener, so as to hold the same normally at right angles with respect to the poles.

Instead of the particular form of construc-

tion and of the means for attaching the device to the pole, shown in the drawings, I may employ any other preferred form of construction, and I would therefore have it understood
 5 that I do not desire to limit myself to the precise form of construction shown in the drawings and herein described.

I am aware of the fact that prior to my invention it has been proposed to use a rod secured at each end to the doubletree and passing through a strap mounted on the tongue in rear of the doubletree, said rod having an abutment or stop on each side of the strap, and I do not claim this as of my invention.
 10 This construction possesses the very objectionable features that I am desirous of avoiding in my invention. That is to say the harness and the doubletree are subject to sudden sharp strains, there being no spring to gradually lessen the jar or strain. The quick pull
 20 which one of the draft animals exerts forces it violently forward and the abutment strikes against the strap and not only jars the whole vehicle but as above said will have a tendency
 25 to break the doubletree and the straps by which the animals are attached to the single-trees.

I am also aware that a doubletree pivoted to the rear end of the tongue by means of a rearwardly extending arm has been combined with springs secured between two forwardly extending lugs attached to the doubletree and bearing on either side of an abutment on the tongue. Nor do I claim this as my invention. I obviate in my construction the serious disadvantages incident to the use of a device like this. It will be readily seen that by reason of the doubletree being pivoted at points in rear thereof, and having the
 35 springs arranged between two forwardly projecting lugs, that the pole will be easily rocked from side to side and knocked against the draft animals.

Having thus described my invention, what

I claim as new, and desire to secure by Letters Patent of the United States, is—

1- The combination with the vehicle pole having a guide permanently secured thereto, and the evener pivoted to the pole, of an arch bar secured at its ends to the evener and
 50 formed with stops, and having a part between said stops passing through said guide on the pole, and springs arranged around said bar between said stops and the guide, said bar being formed in two parts whereby it can be
 55 inserted in said guide, substantially as set forth.

2. The combination with the pole, the evener, and the pivot connecting the evener with the pole, of an attachment therefor comprising a
 60 brace iron of generally U-shape, formed in two parts F and G, adapted for engagement at its opposite ends with the evener upon opposite sides of the pole, and provided with a central part concentric with the pivot and
 65 passing through a guide secured permanently to the pole, stops formed on said parts F and G upon either side of the guide, and springs adapted to be interposed between said stops and said guide, said two parts F and G hav-
 70 ing means for securing them together, substantially as set forth.

3. An attachment for vehicle poles comprising a brace iron of a generally arch or U shape, and formed from the two sections F and G, one
 75 of which is provided with a screw-threaded shank and the other with a screw-threaded socket for the reception of the same, the springs E E and shoulders e e formed respectively upon the parts F and G, substantially
 80 as and for the purpose described.

In testimony whereof I sign this specification in the presence of two witnesses.

FRANK QUEISZER.

Witnesses:

JOHN E. WILES,
 M. M. WILES.