



(19) **United States**

(12) **Patent Application Publication**
Forster et al.

(10) **Pub. No.: US 2013/0268067 A1**

(43) **Pub. Date: Oct. 10, 2013**

(54) **PROSTHETIC HEART VALVES, SCAFFOLDING STRUCTURES, AND SYSTEMS AND METHODS FOR IMPLANTING OF SAME**

Related U.S. Application Data

(63) Continuation of application No. 11/066,126, filed on Feb. 25, 2005, now Pat. No. 8,430,925.

(60) Provisional application No. 60/548,731, filed on Feb. 27, 2004, provisional application No. 60/559,199, filed on Apr. 1, 2004.

(71) Applicants: **David C. Forster**, Los Altos Hills, CA (US); **Scott Heneveld**, Whitmore, CA (US); **Brandon G. Walsh**, Syracuse, UT (US); **Richard S. Ginn**, Gilroy, CA (US)

Publication Classification

(51) **Int. Cl.**
A61F 2/24 (2006.01)

(52) **U.S. Cl.**
CPC *A61F 2/2418* (2013.01)
USPC **623/2.17**

(72) Inventors: **David C. Forster**, Los Altos Hills, CA (US); **Scott Heneveld**, Whitmore, CA (US); **Brandon G. Walsh**, Syracuse, UT (US); **Richard S. Ginn**, Gilroy, CA (US)

(73) Assignee: **CardiacMD, Inc.**, Los Altos Hills, CA (US)

(57) **ABSTRACT**

Prosthetic valves and their component parts are described, as are prosthetic valve delivery devices and methods for their use. The prosthetic valves are particularly adapted for use in percutaneous aortic valve replacement procedures. The delivery devices are particularly adapted for use in minimally invasive surgical procedures.

(21) Appl. No.: **13/829,542**

(22) Filed: **Mar. 14, 2013**

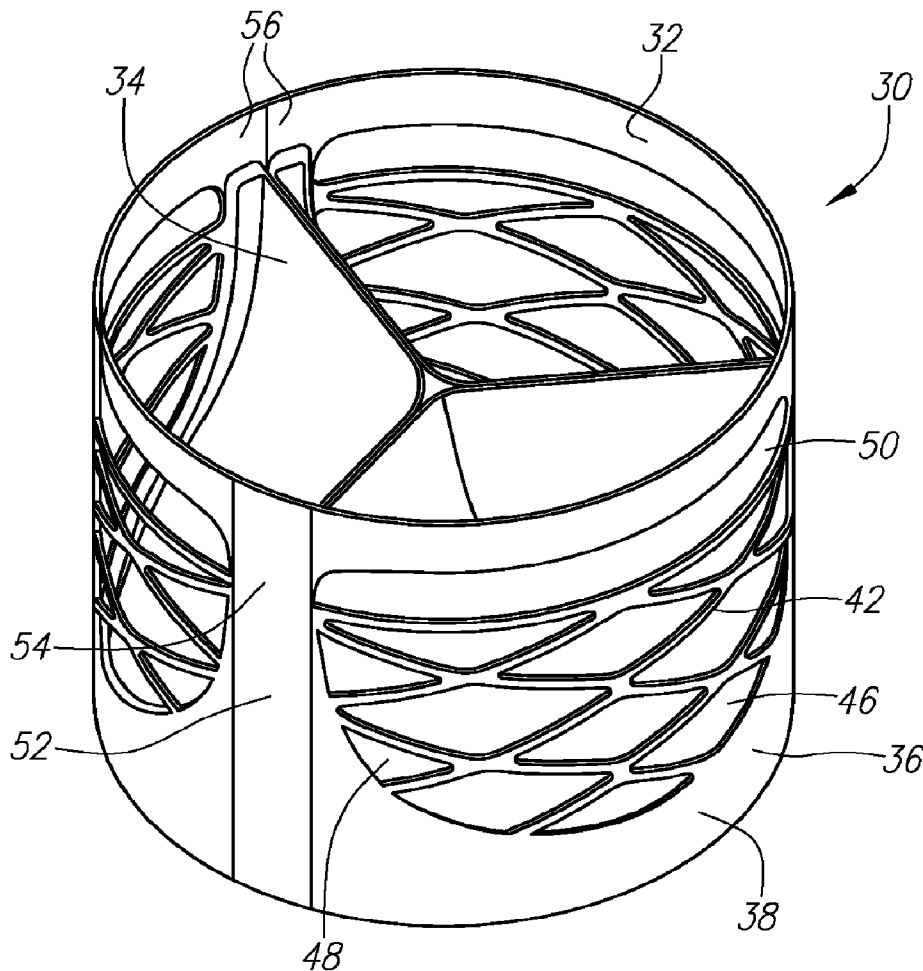

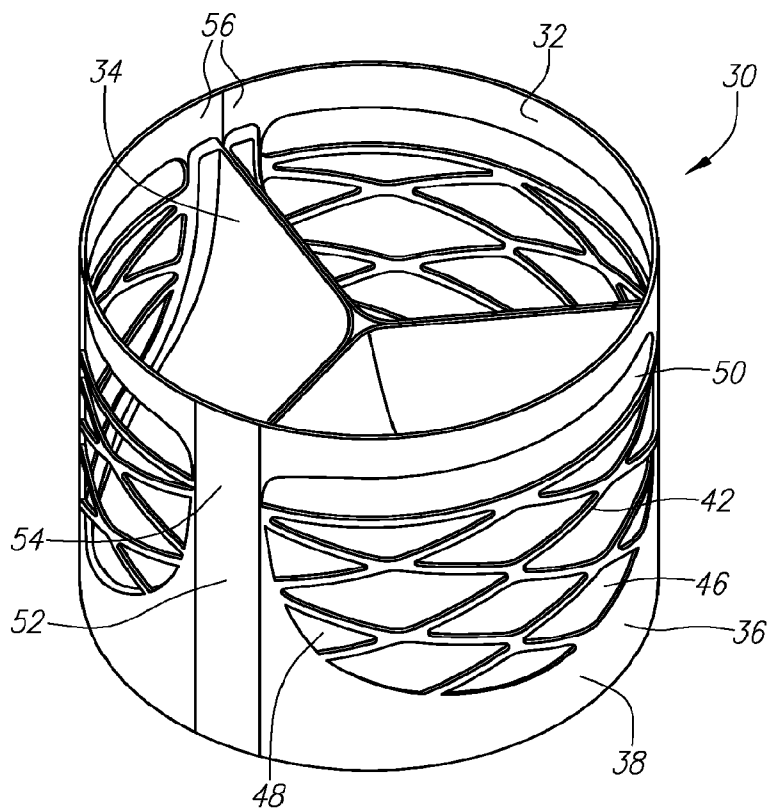

FIG. 1A

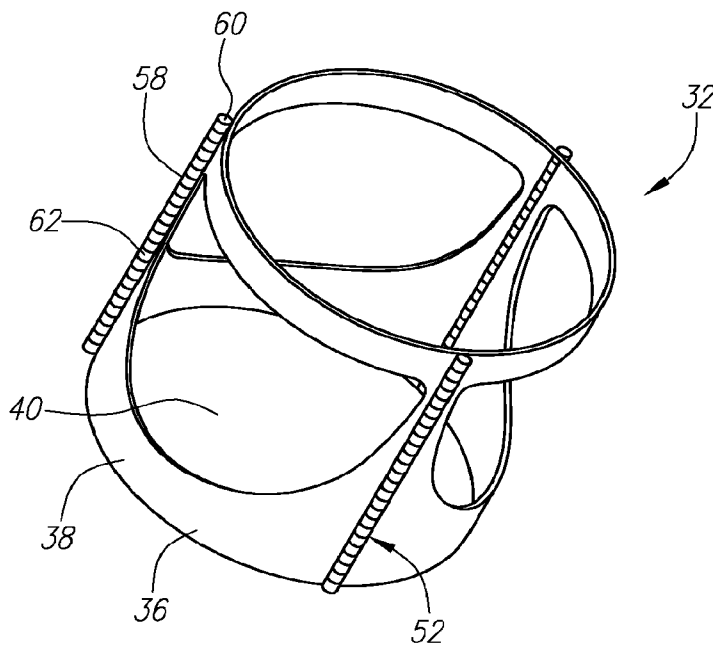

FIG. 1B

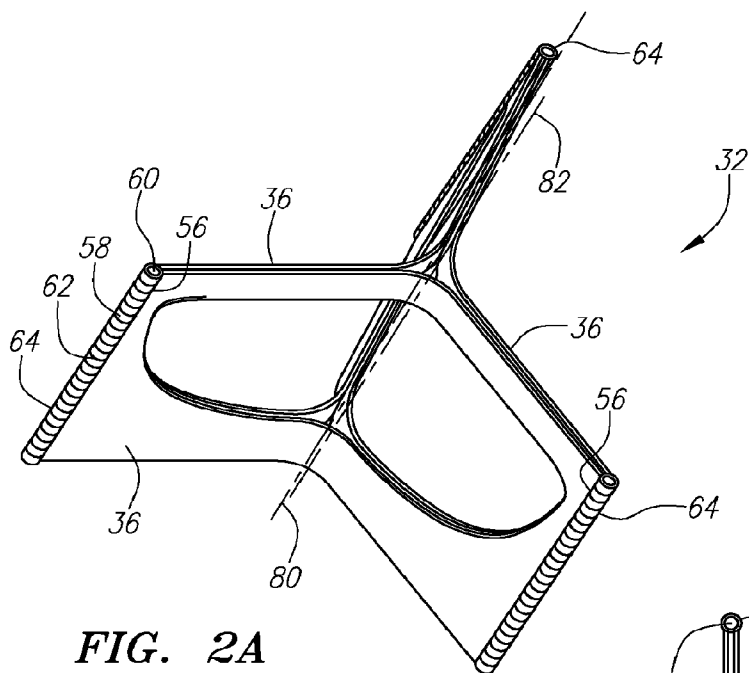

FIG. 2A

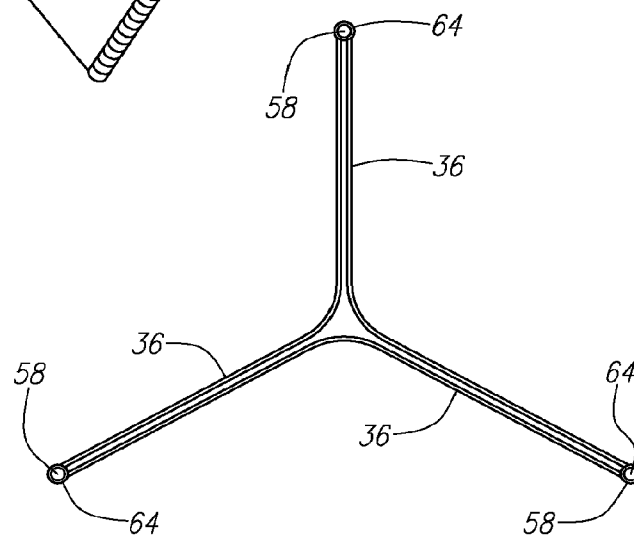

FIG. 2B

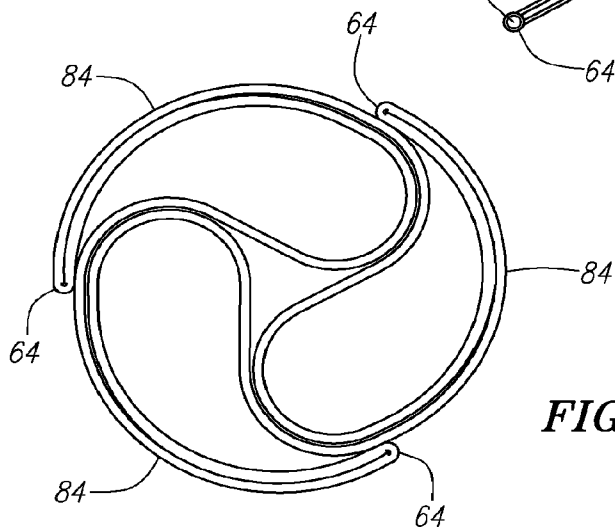

FIG. 2C

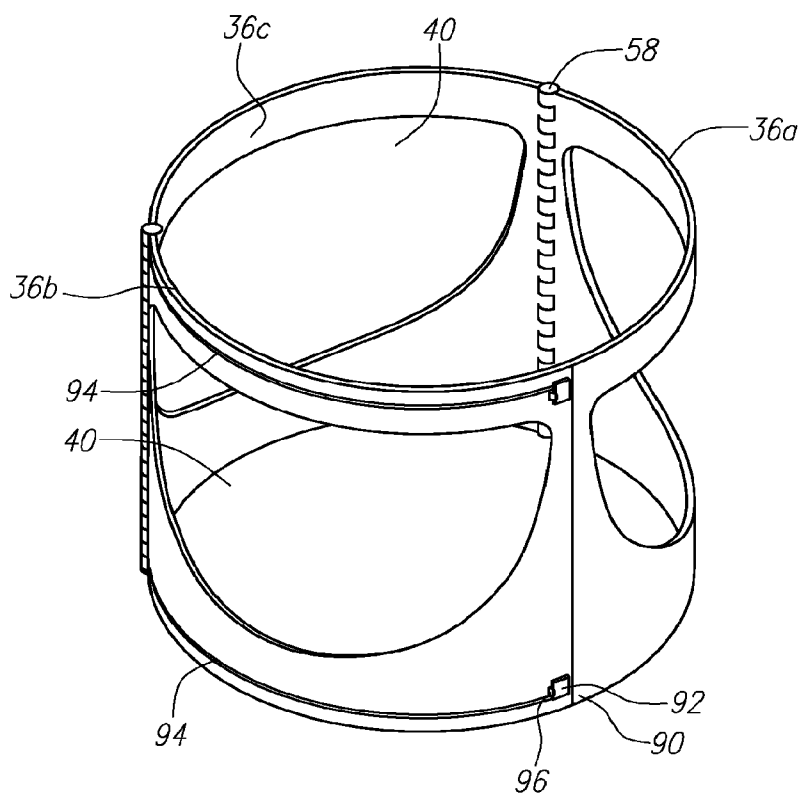

FIG. 3A

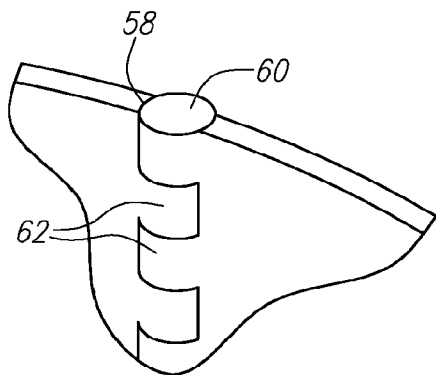

FIG. 3B

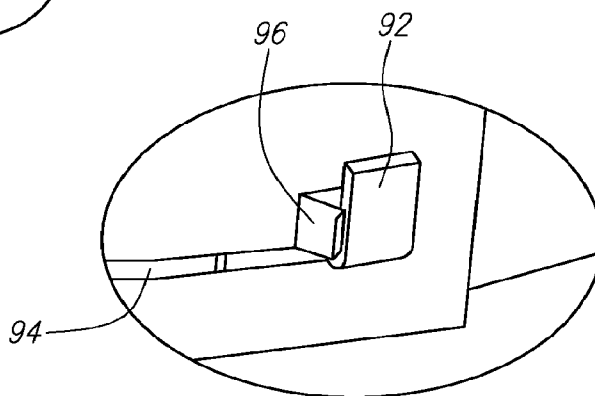

FIG. 3C

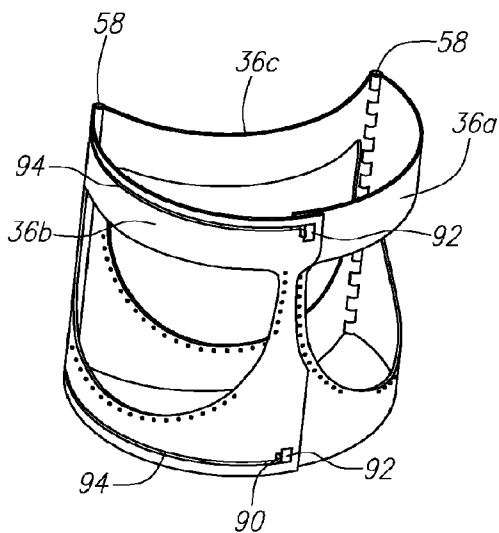

FIG. 3D

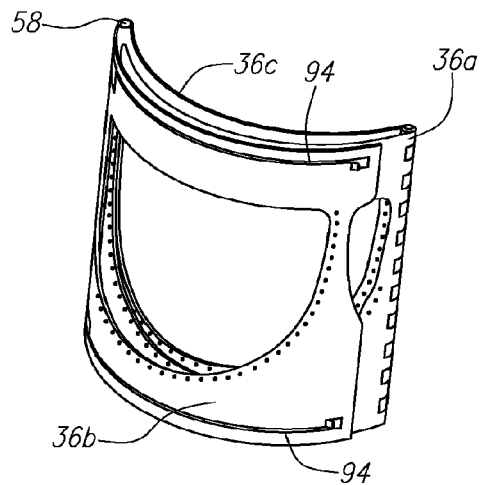

FIG. 3E

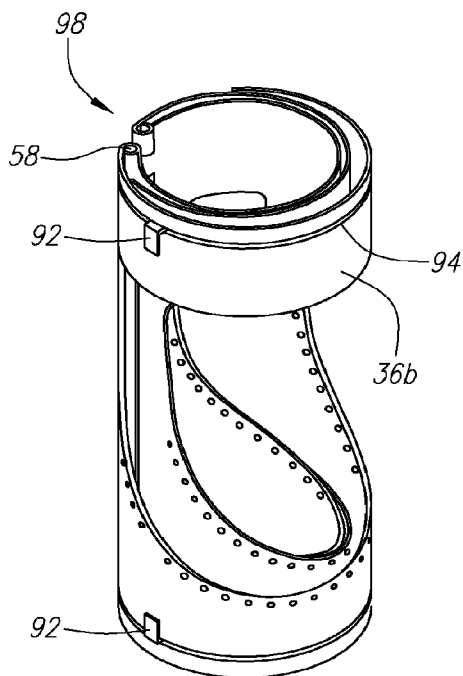

FIG. 3F

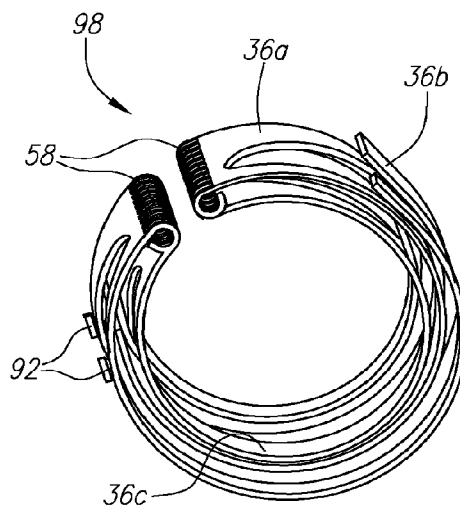
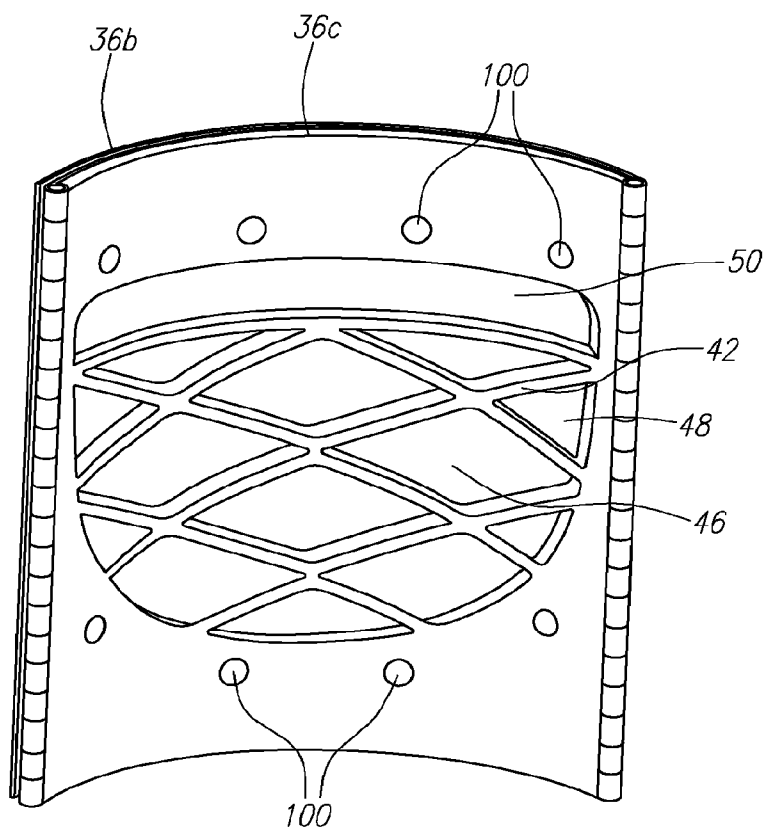
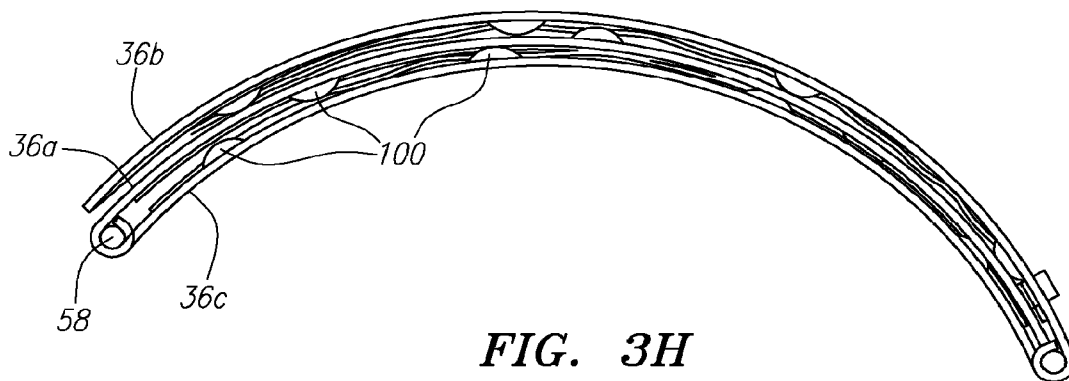

FIG. 3G



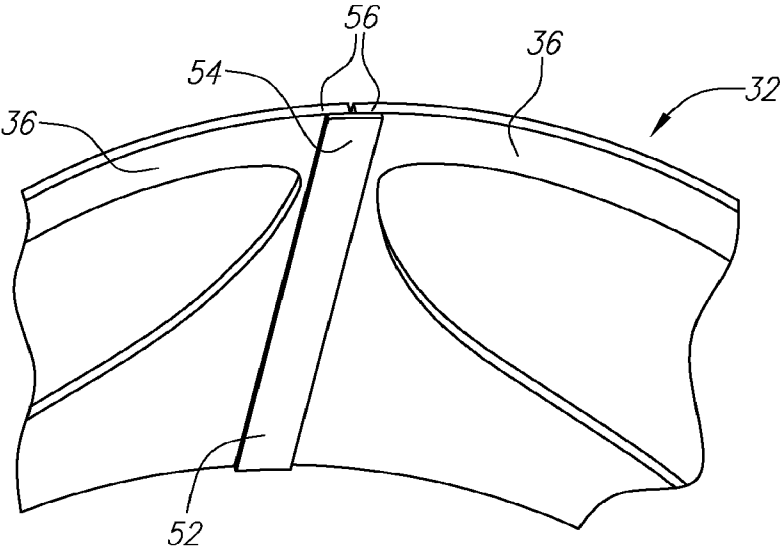

FIG. 4A

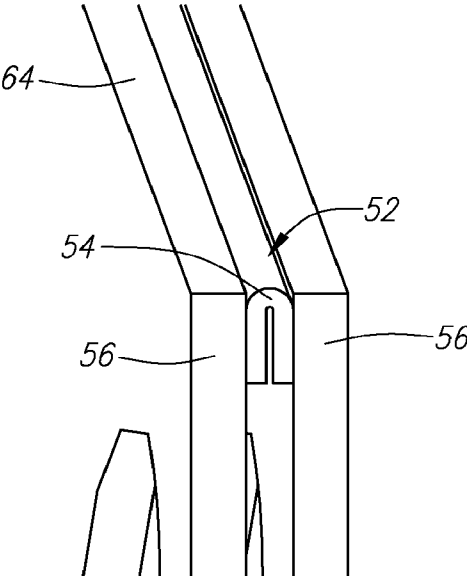

FIG. 4B

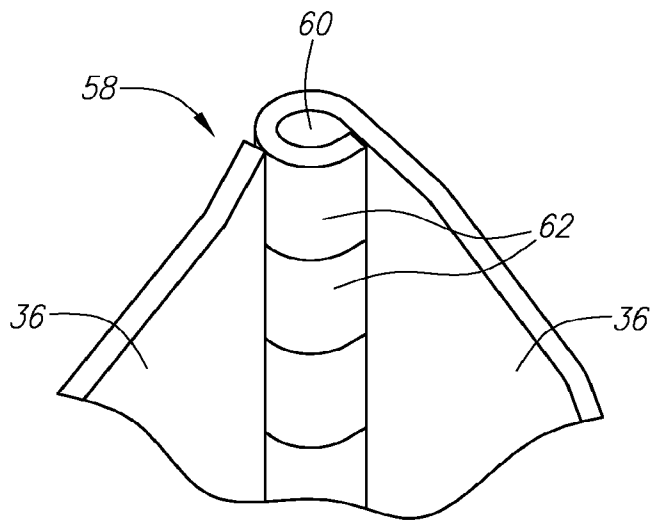

FIG. 4C

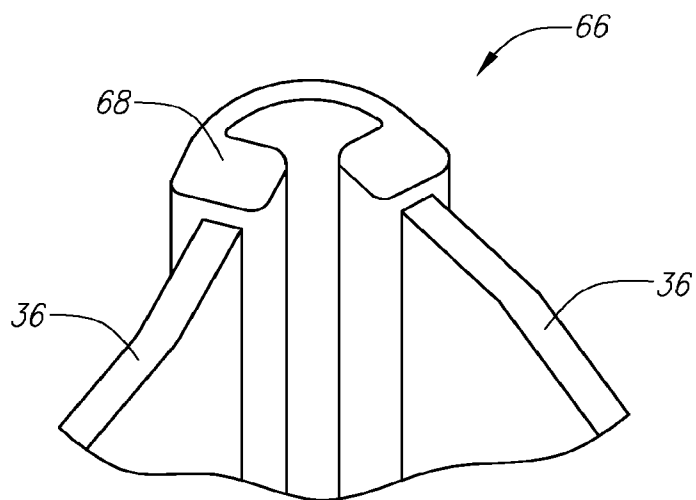

FIG. 4D

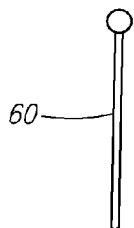

FIG. 5A

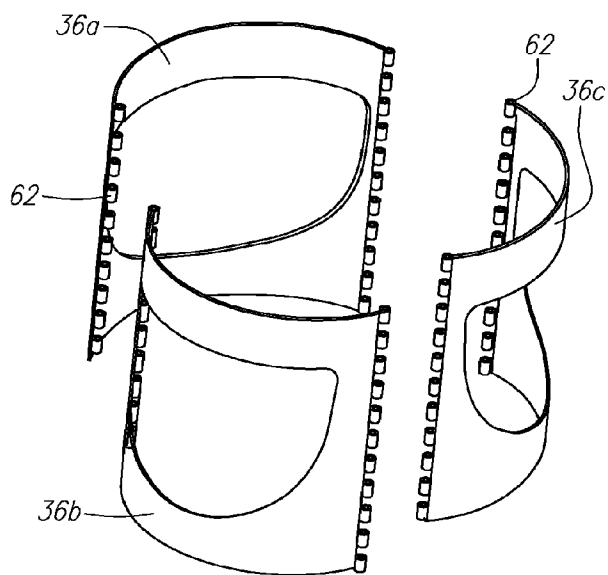
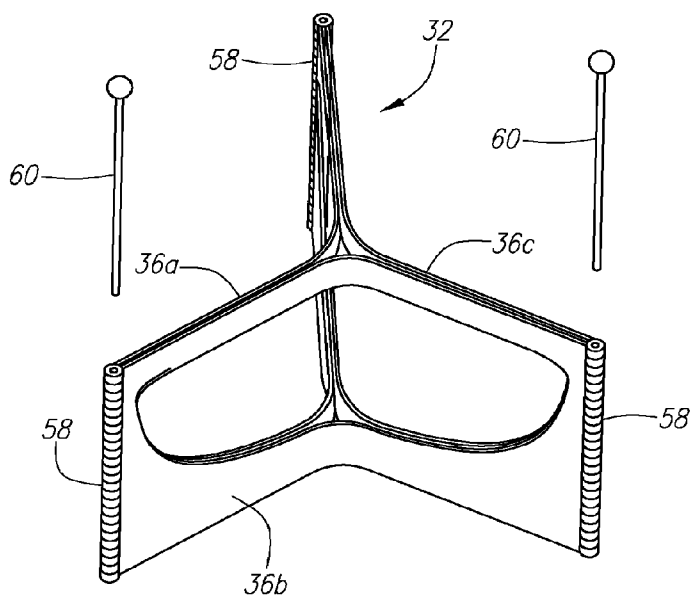

FIG. 5B

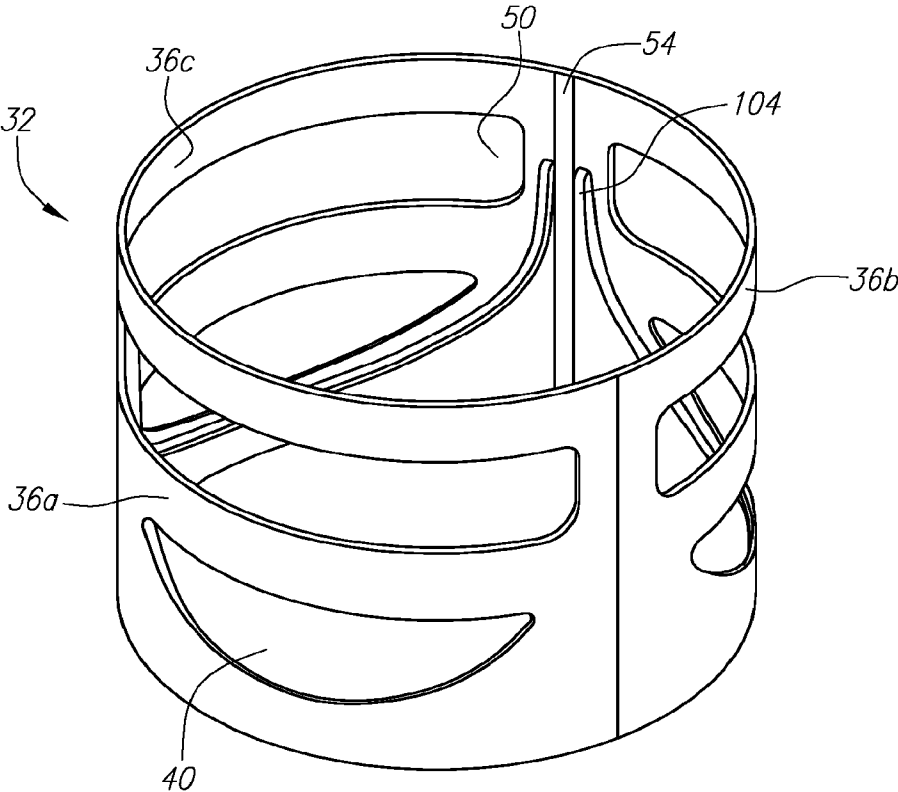

FIG. 6

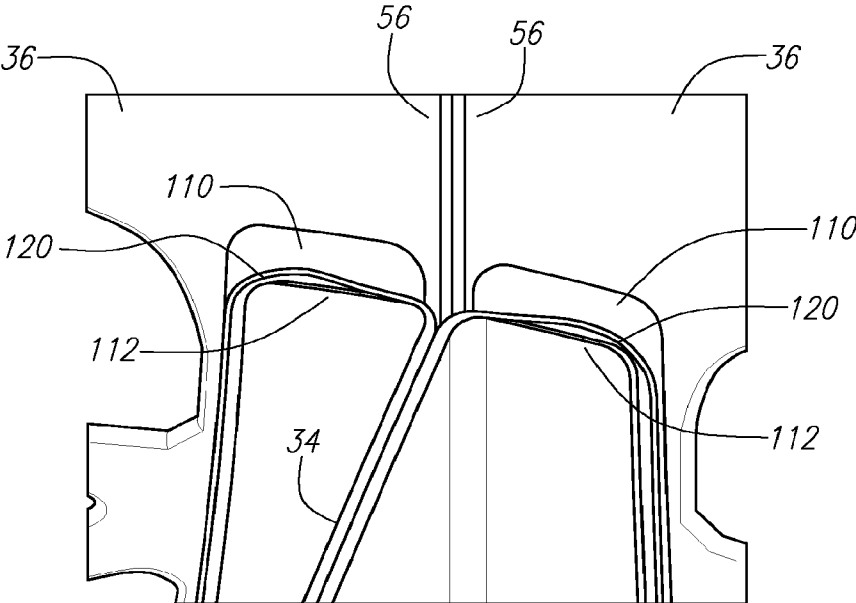

FIG. 7

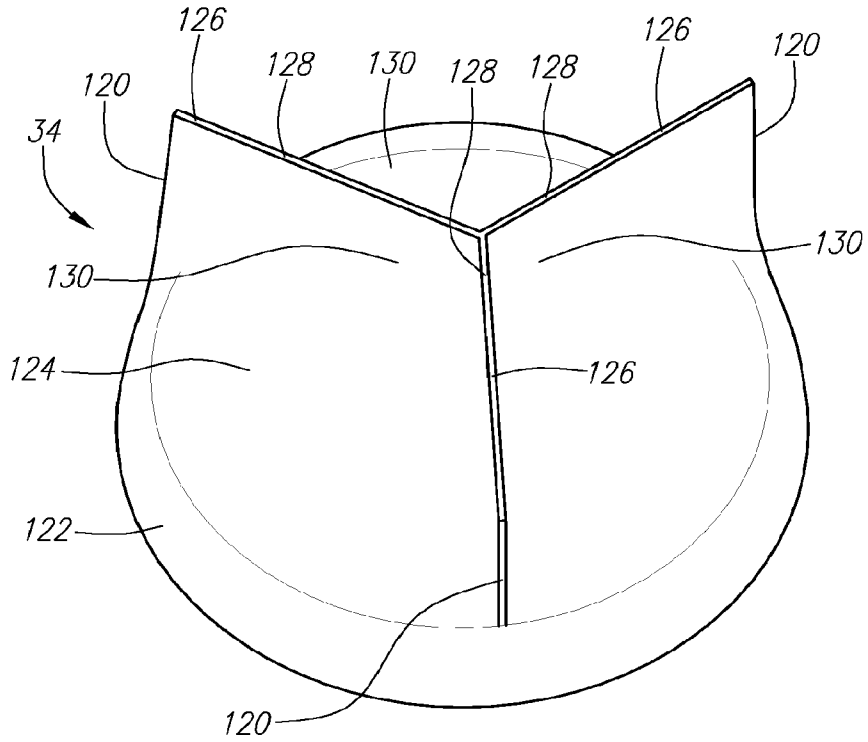

FIG. 8A

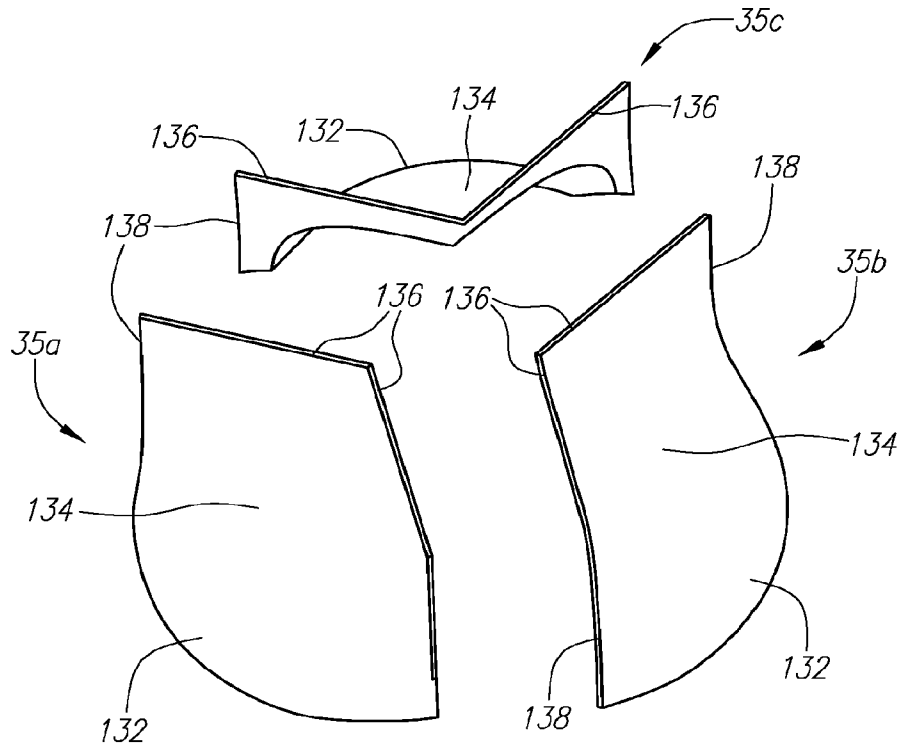
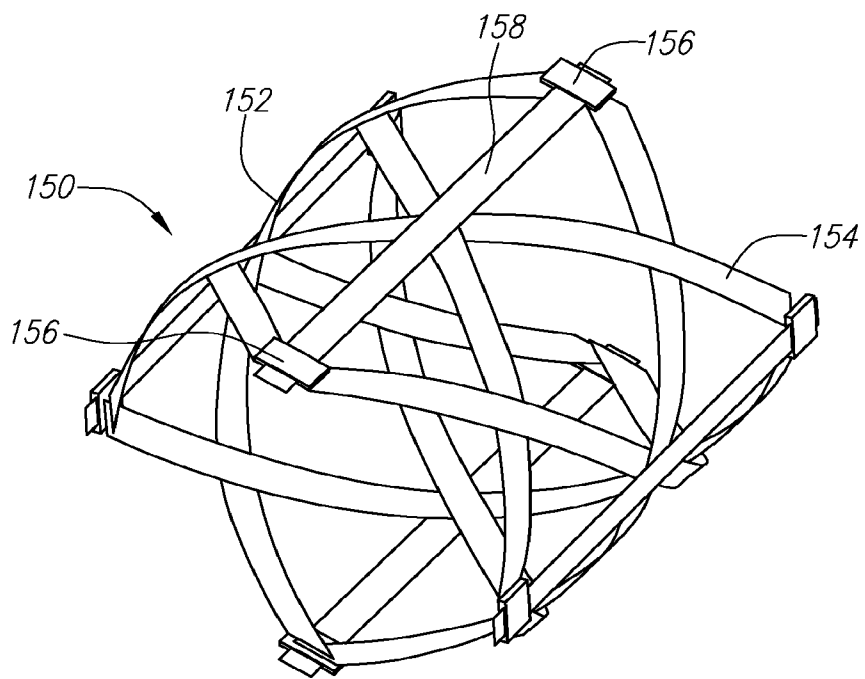
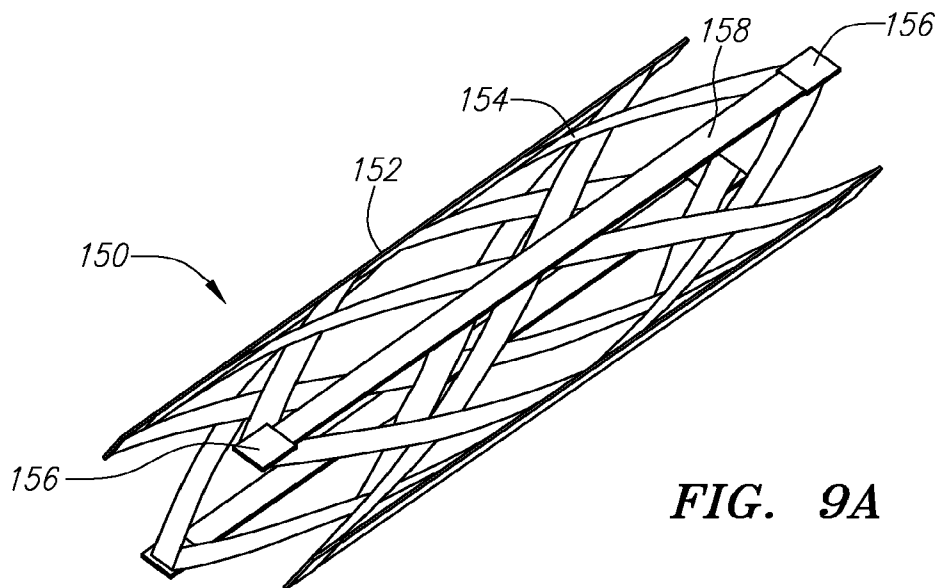

FIG. 8B



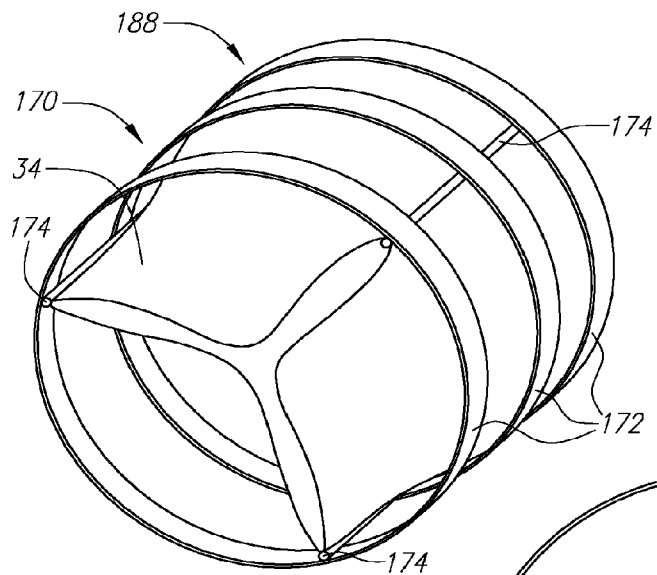

FIG. 10A

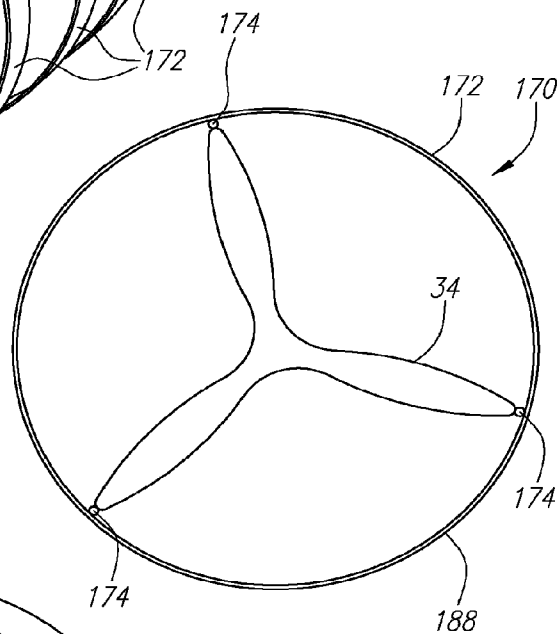

FIG. 10B

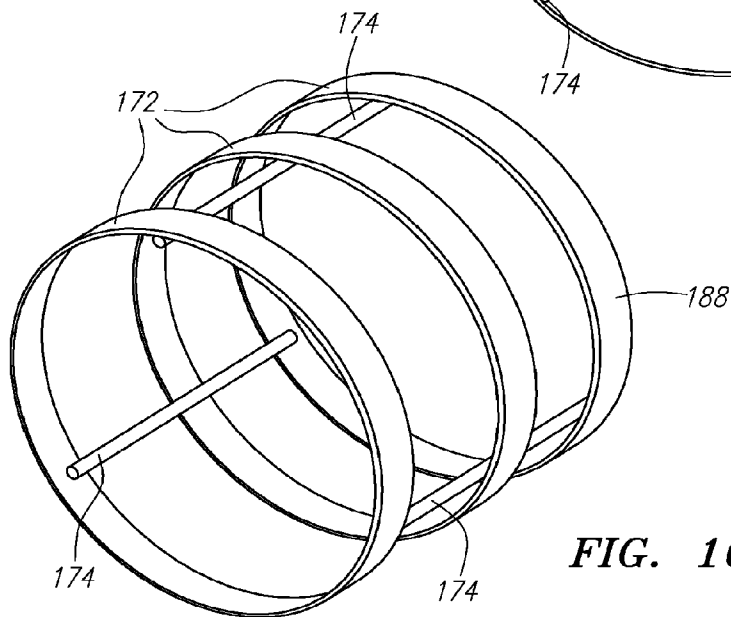

FIG. 10C

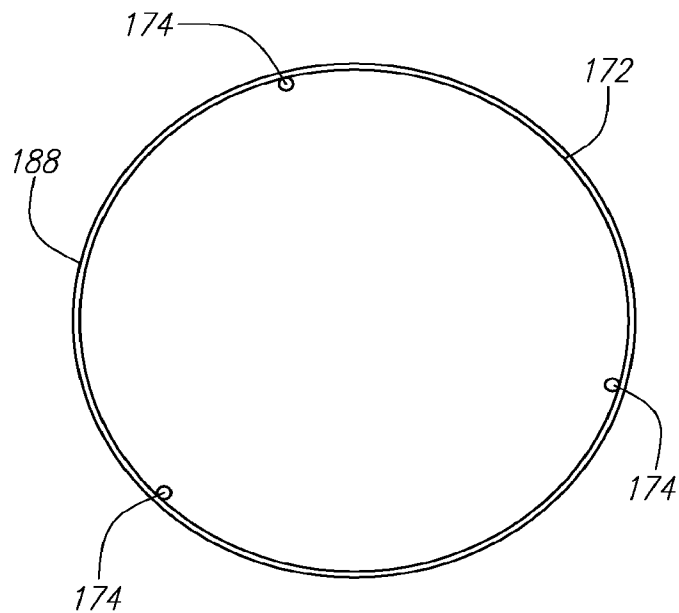

FIG. 10D

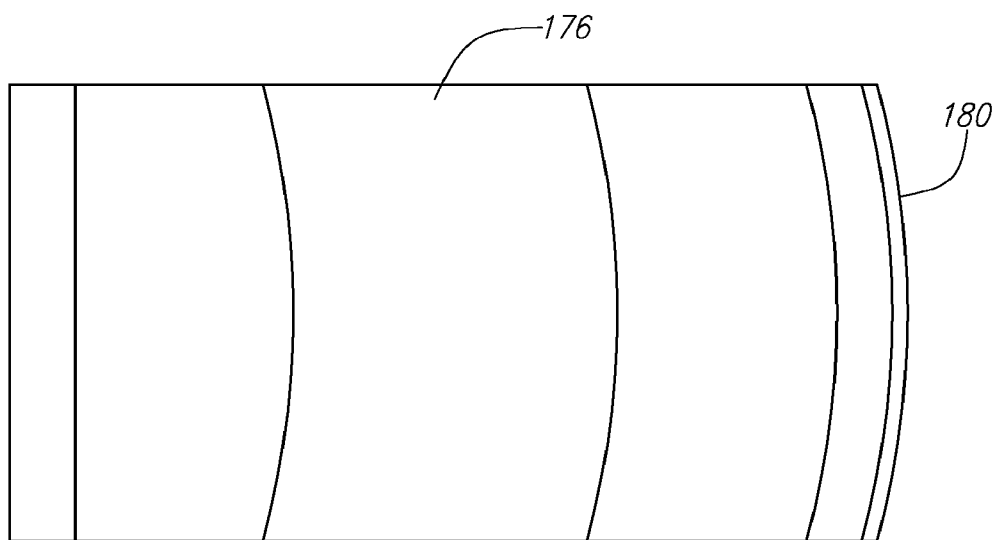

FIG. 10E

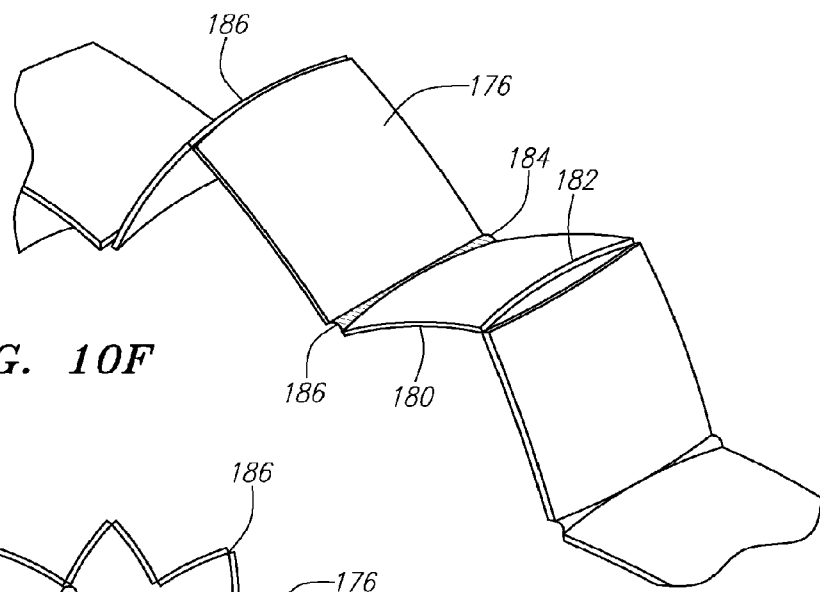

FIG. 10F

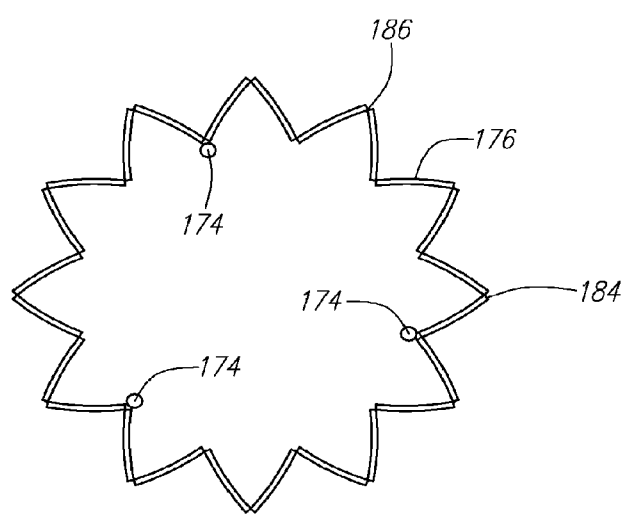

FIG. 10G

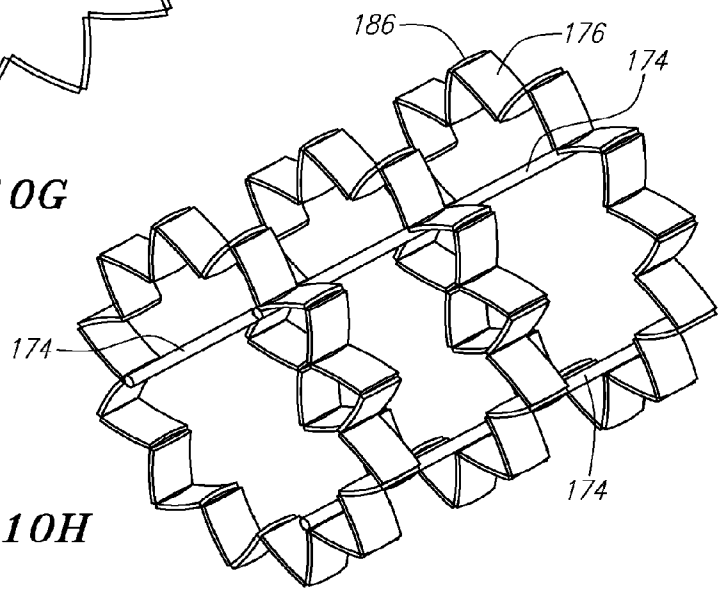

FIG. 10H

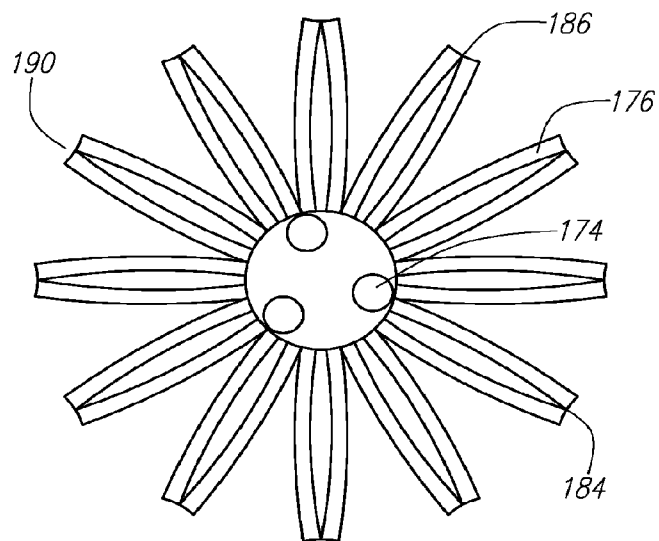

FIG. 10I

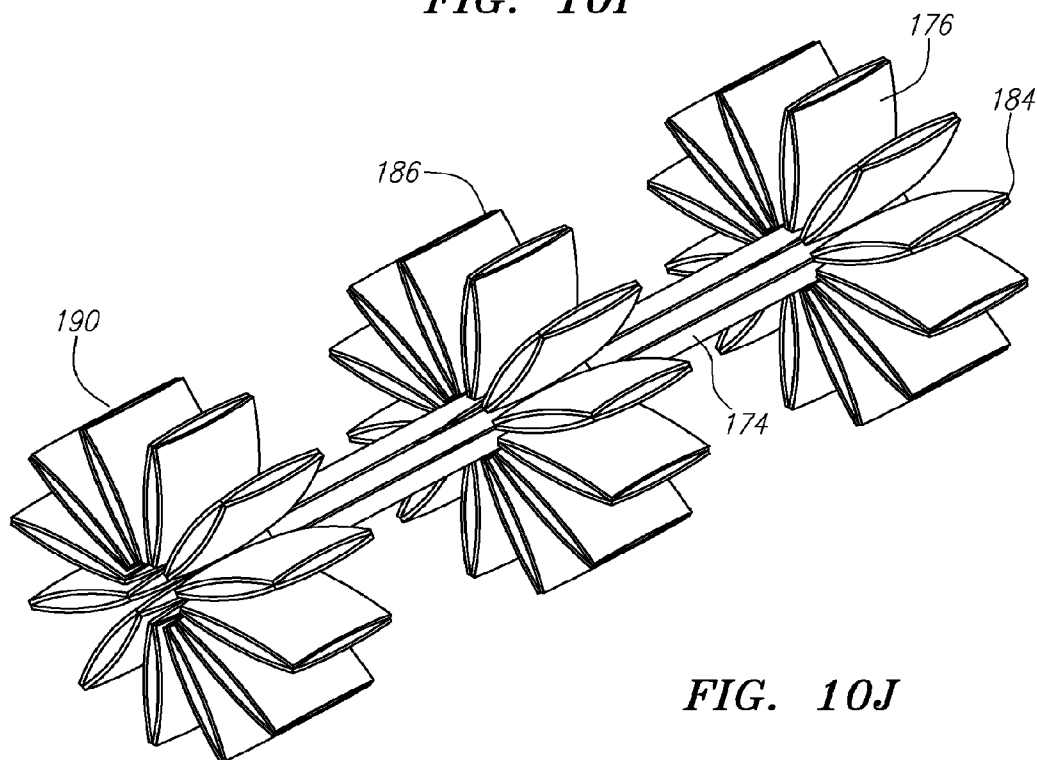

FIG. 10J

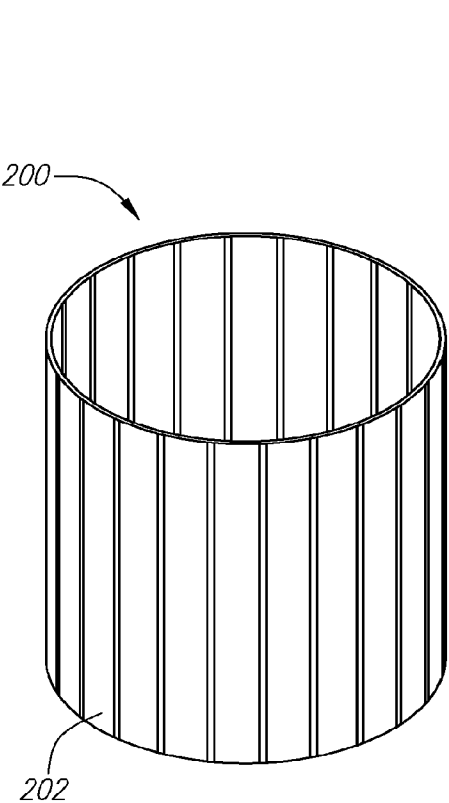

FIG. 11A

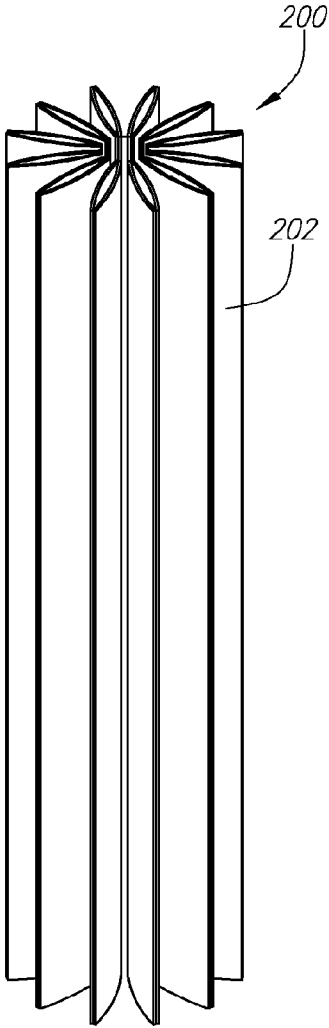

FIG. 11B

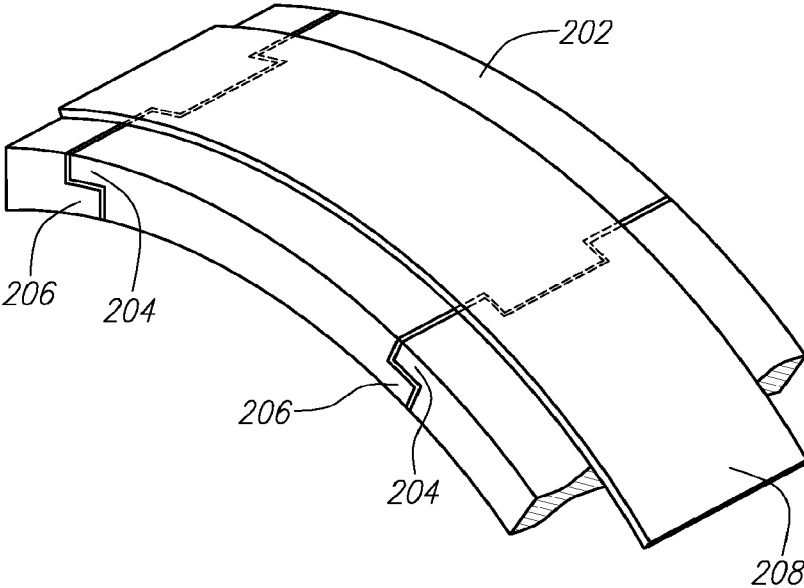

FIG. 11C

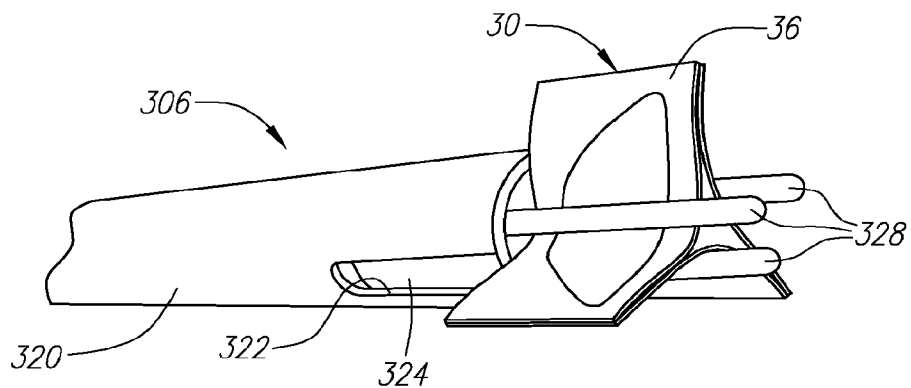

FIG. 12A

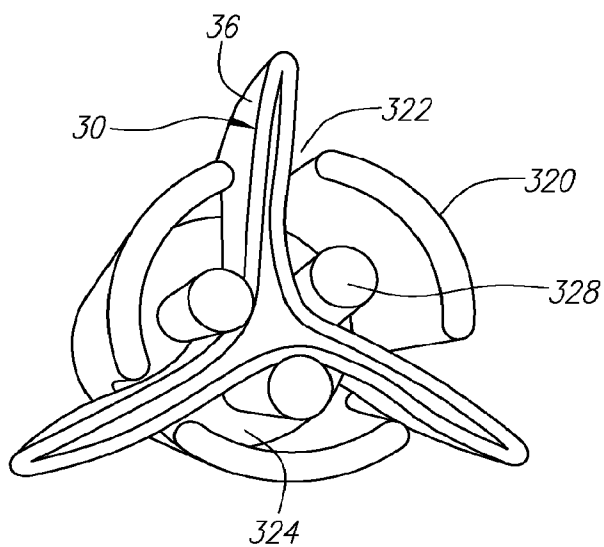

FIG. 12B

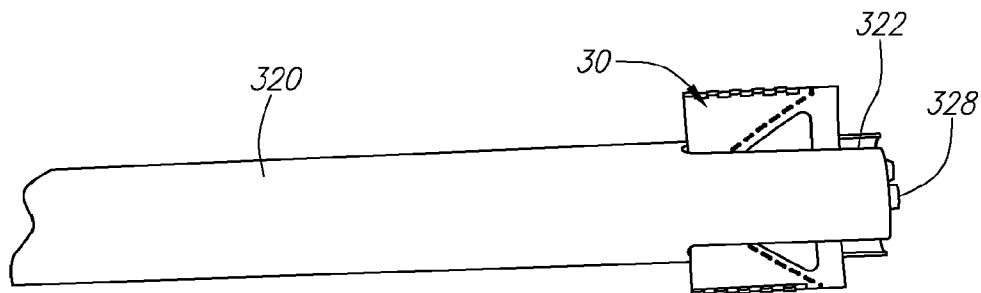

FIG. 12C

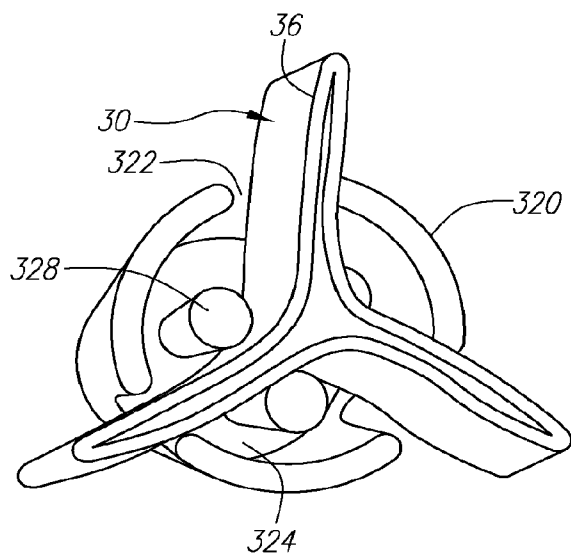

FIG. 12D

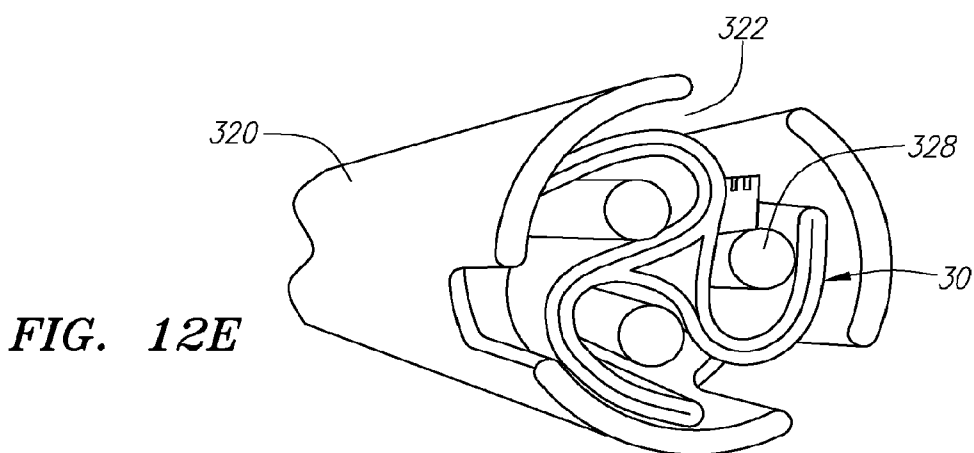

FIG. 12E

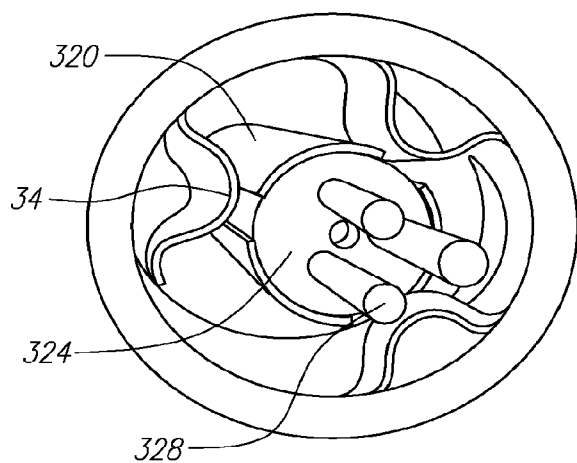
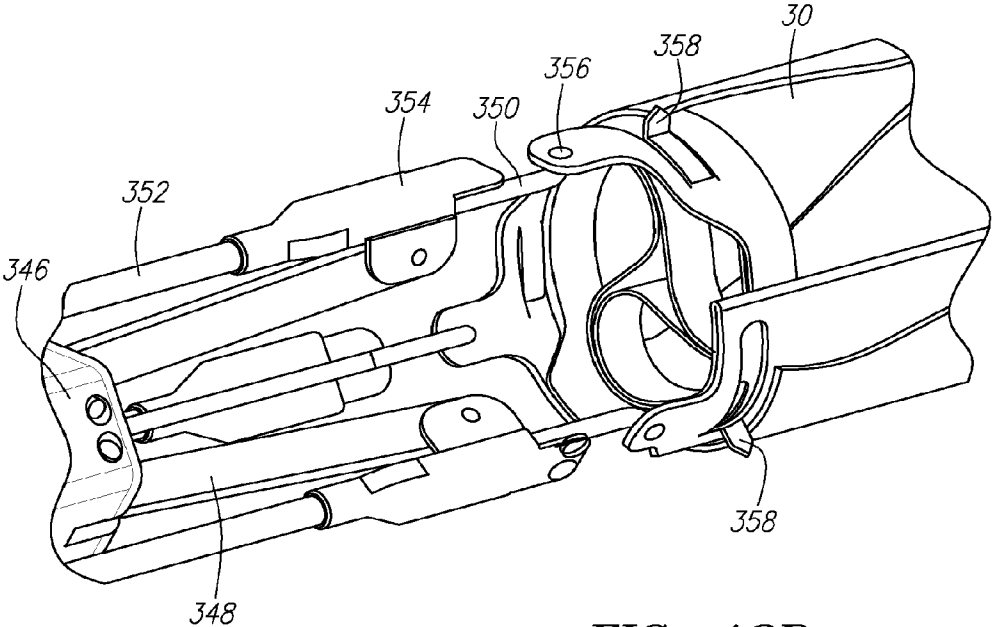
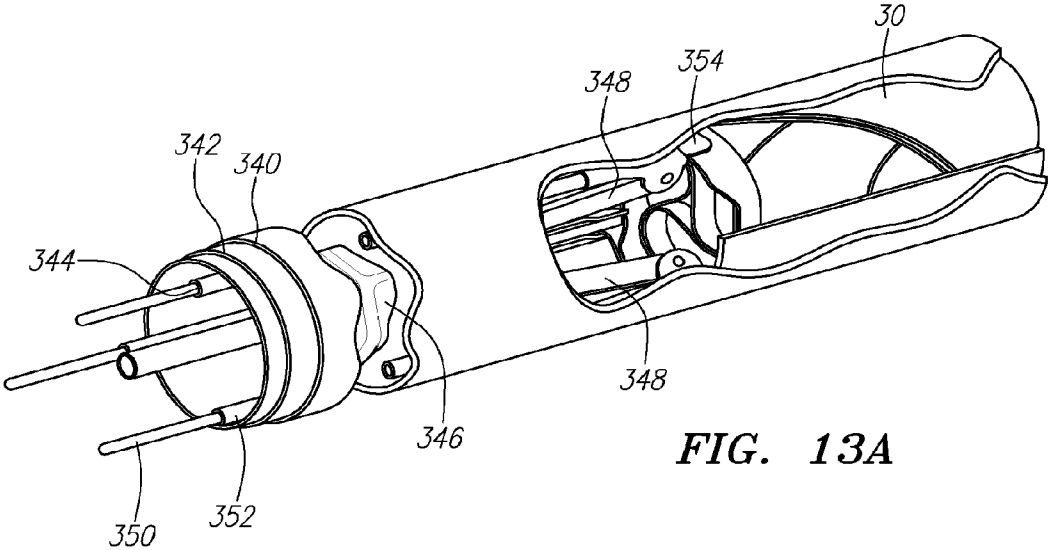

FIG. 12F



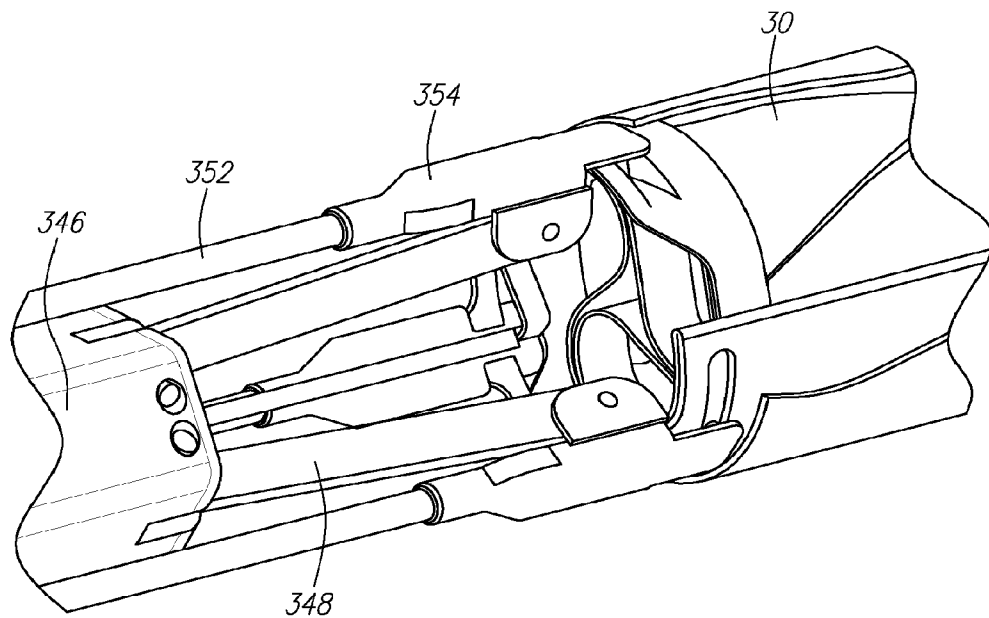

FIG. 13C

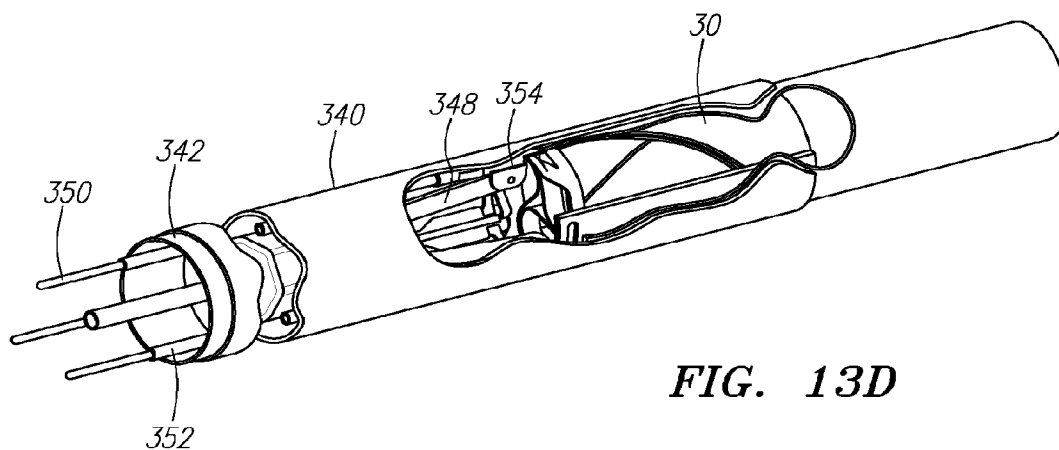

FIG. 13D

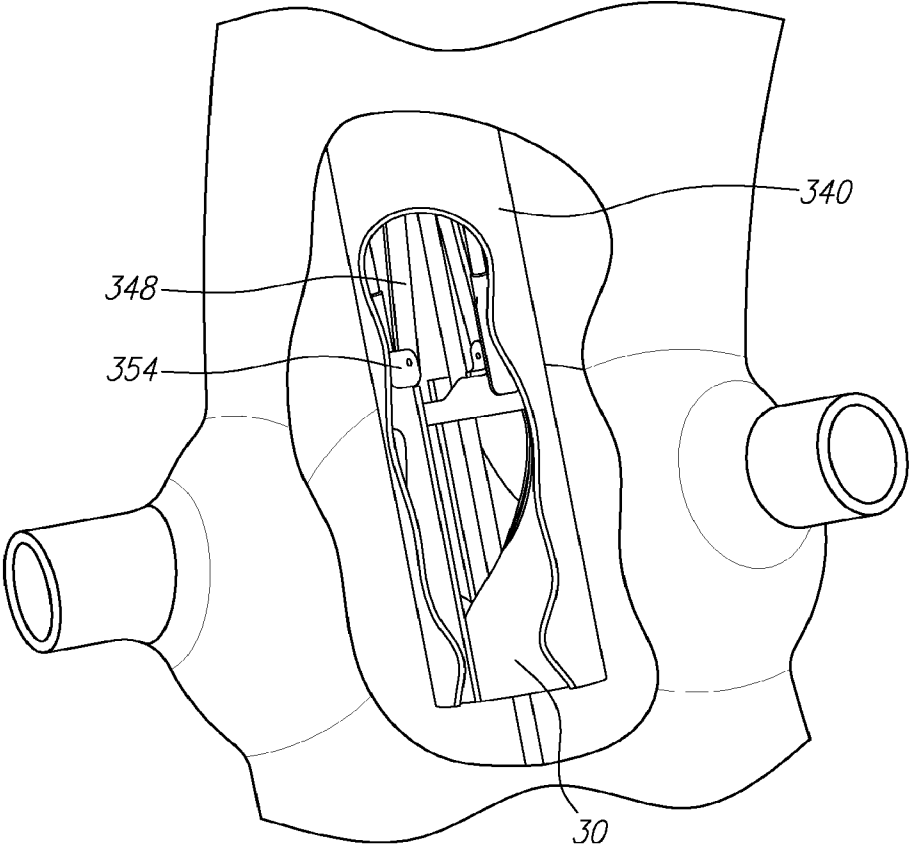

FIG. 13E

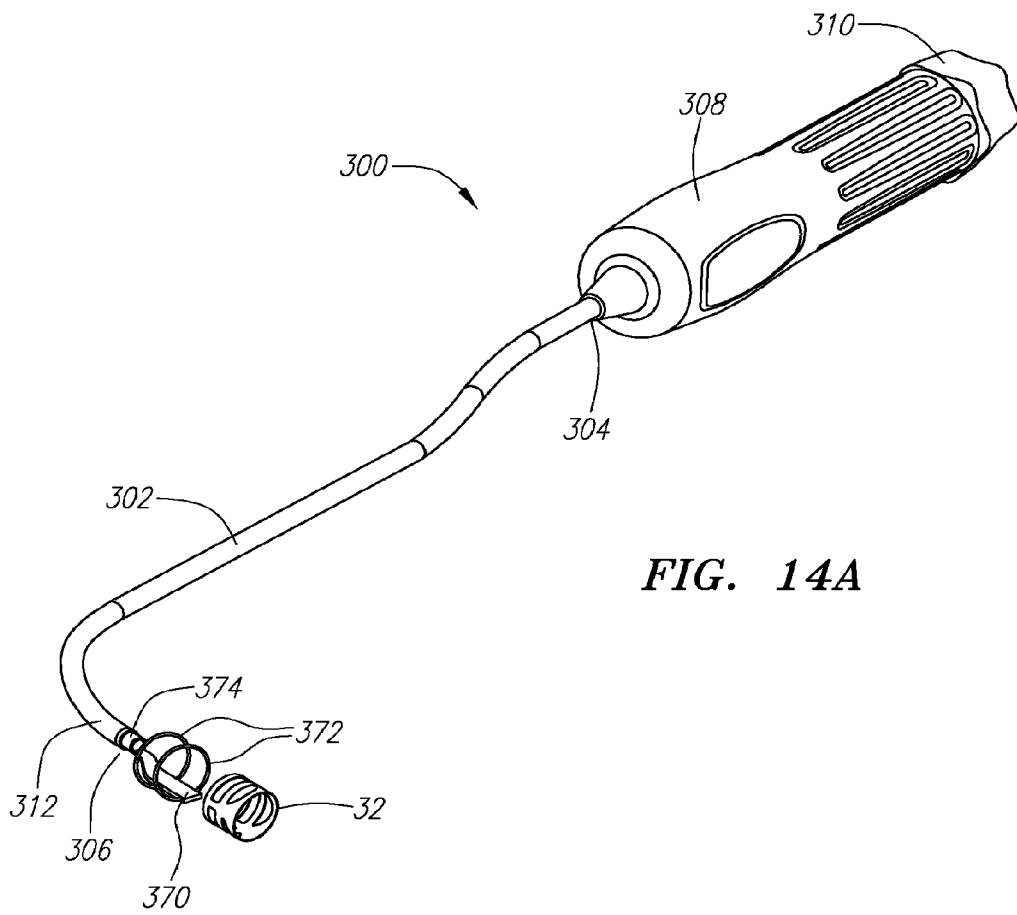

FIG. 14A

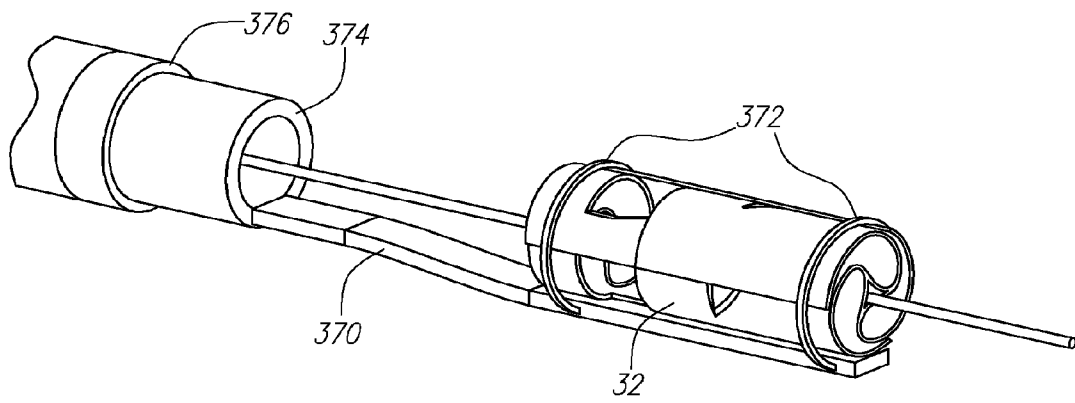

FIG. 14B

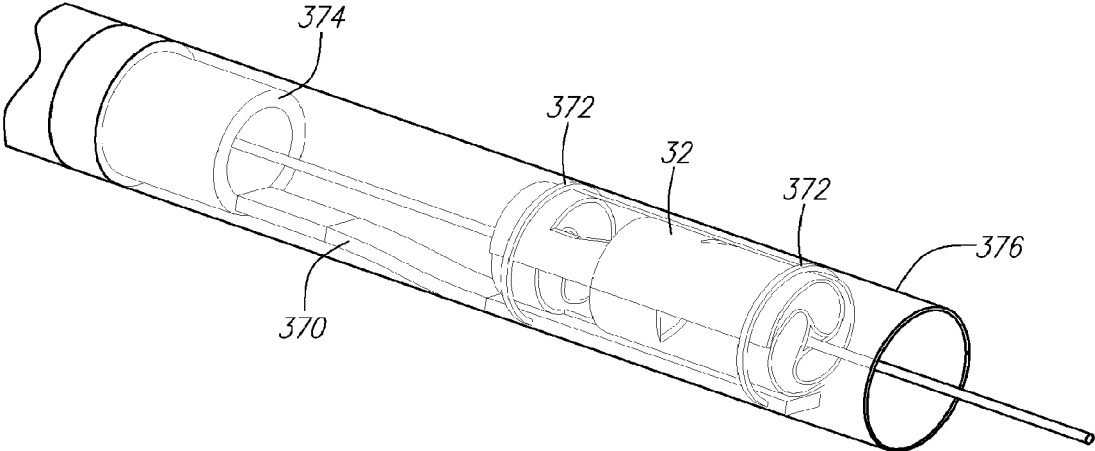

FIG. 14C

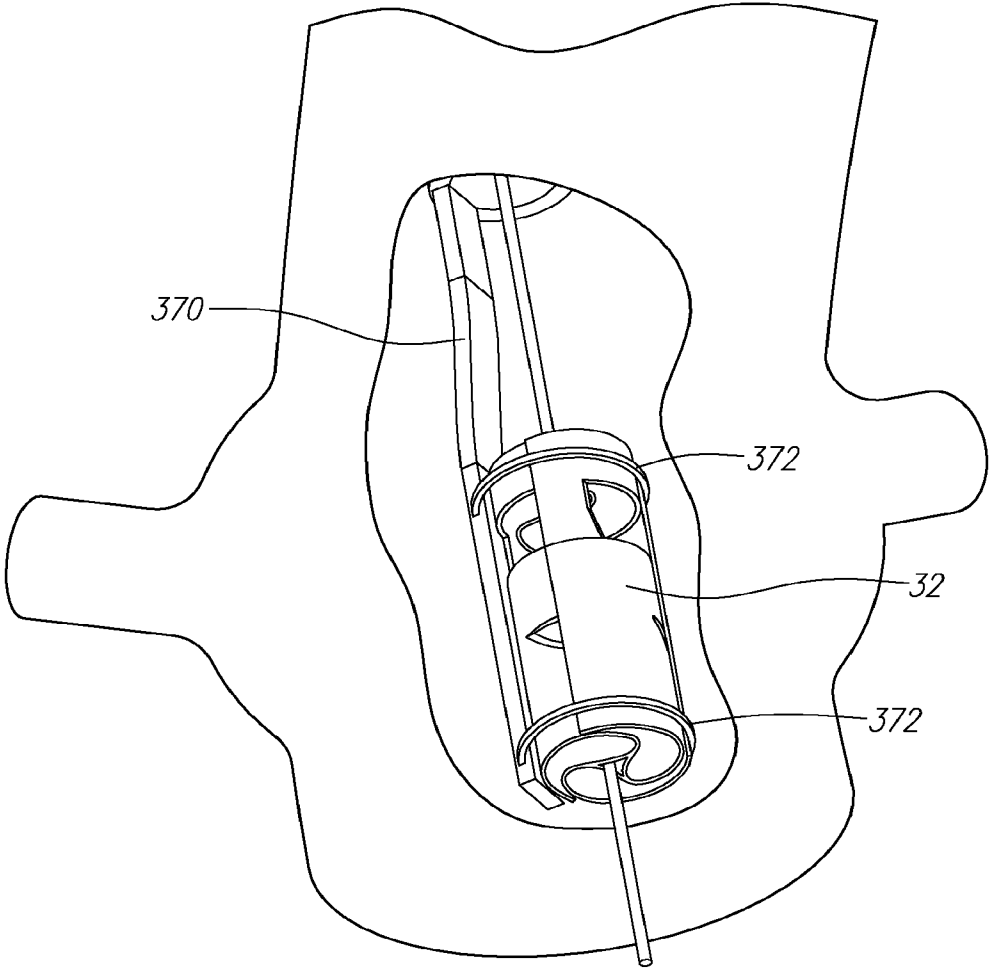

FIG. 14D

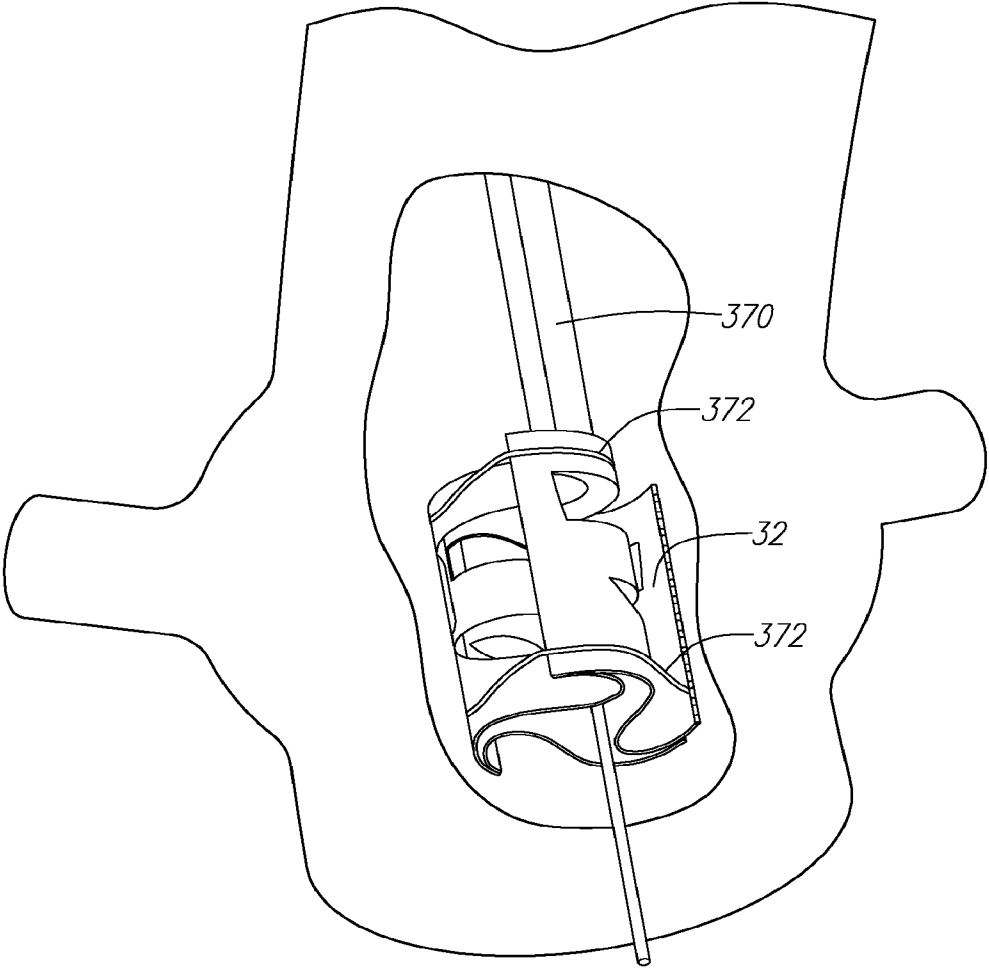
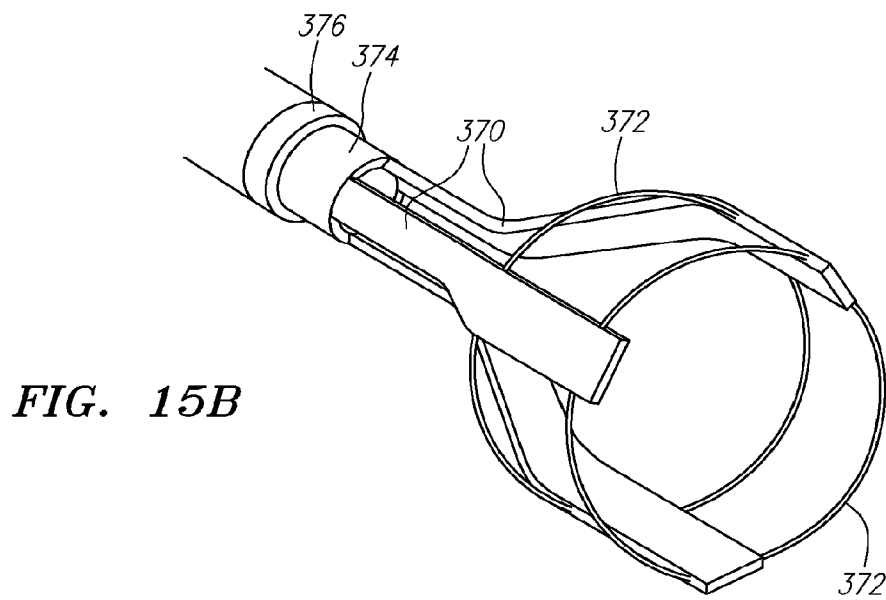
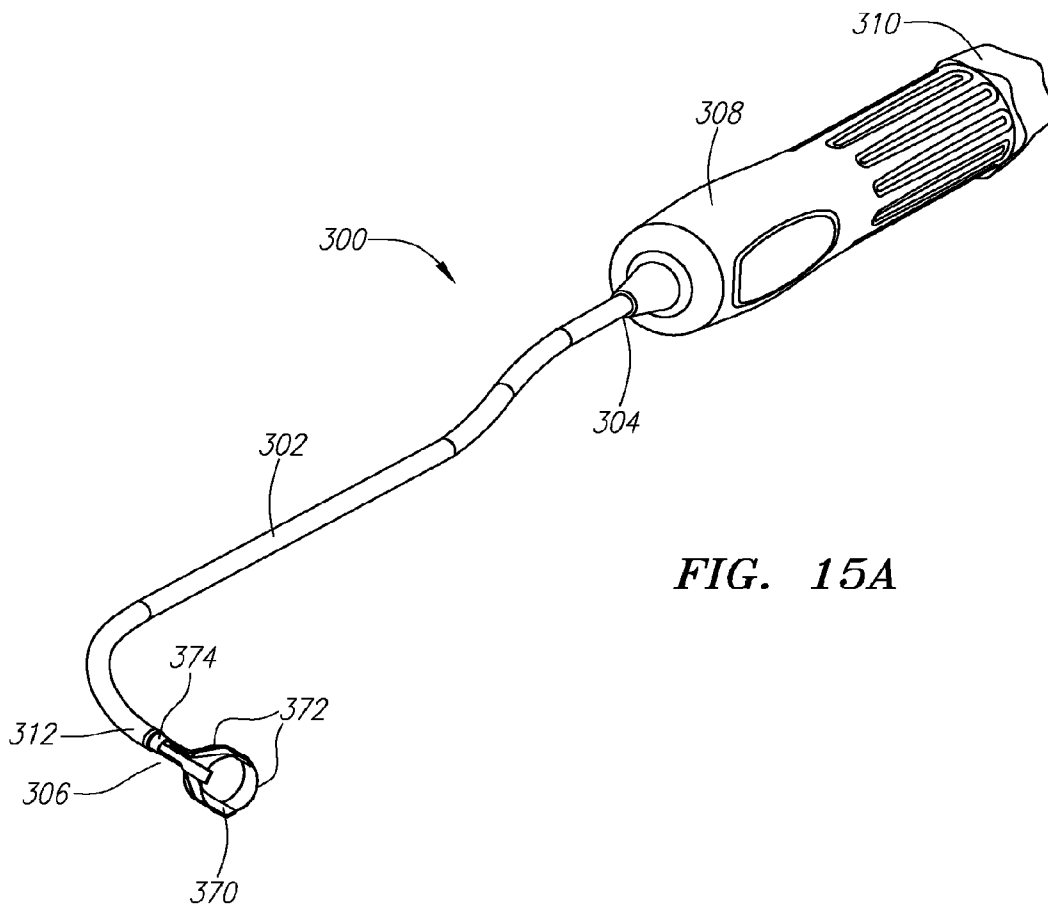

FIG. 14E



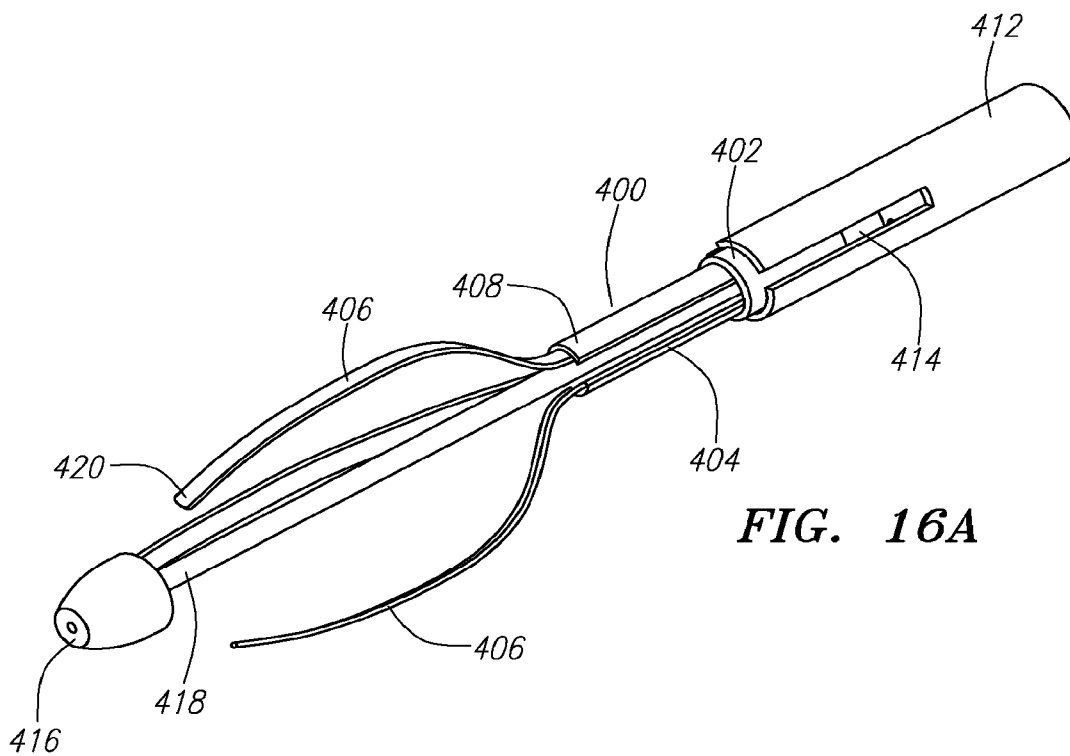

FIG. 16A

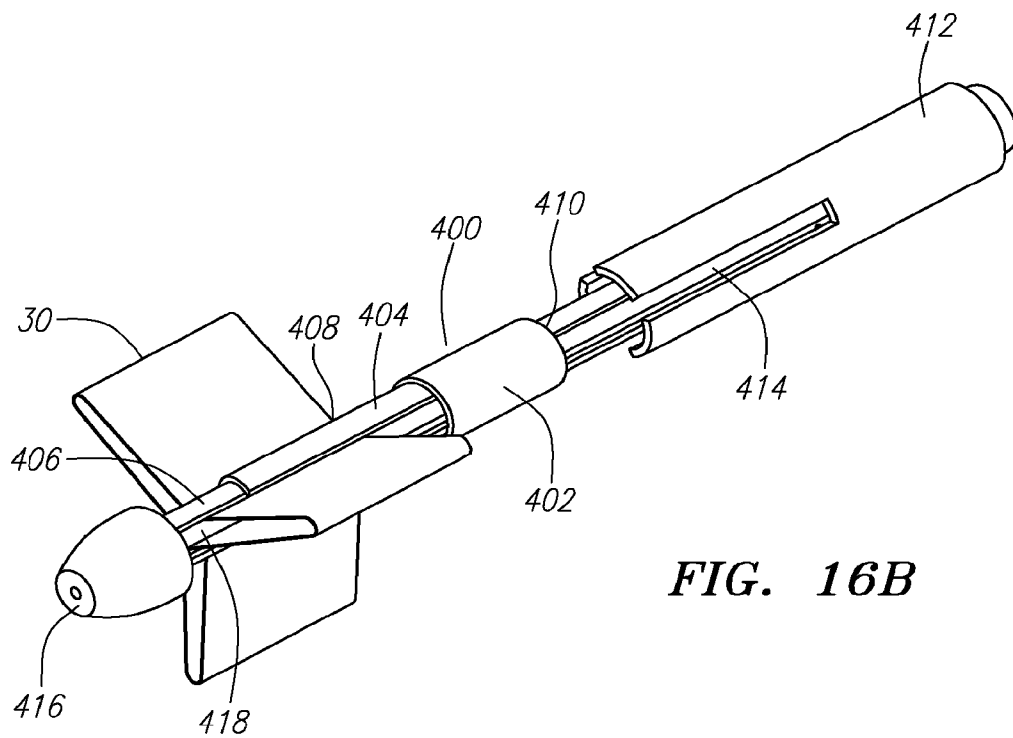
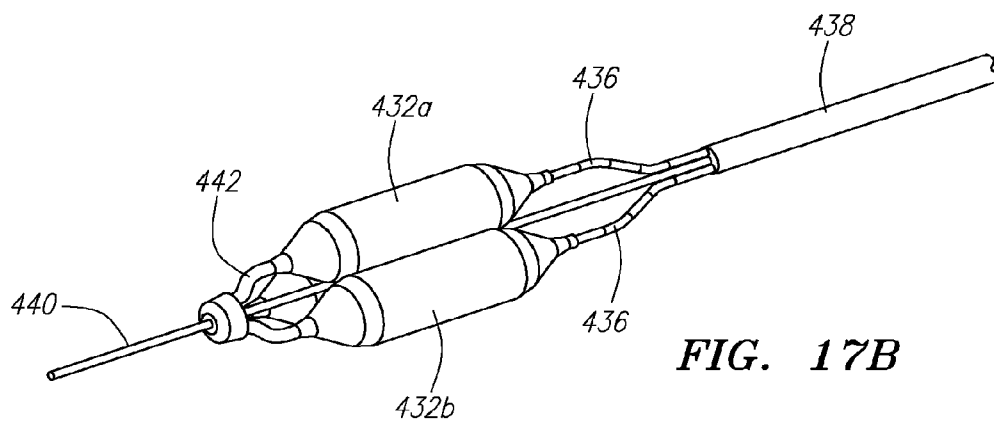
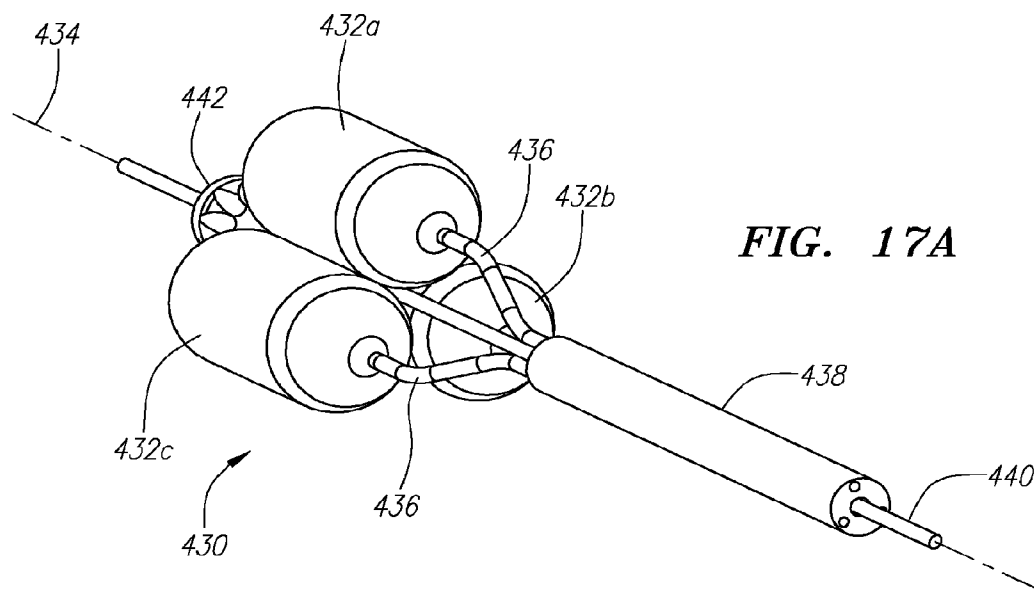
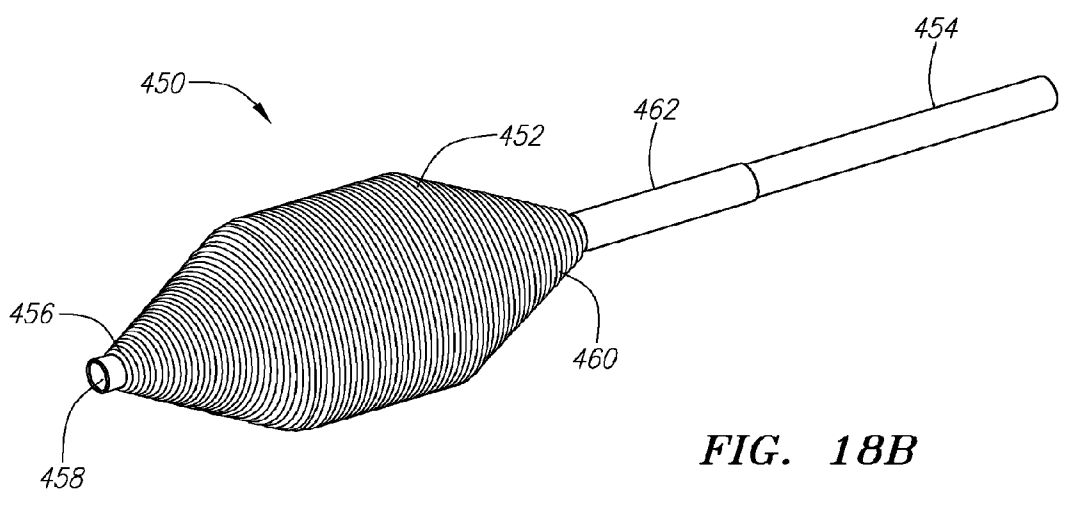
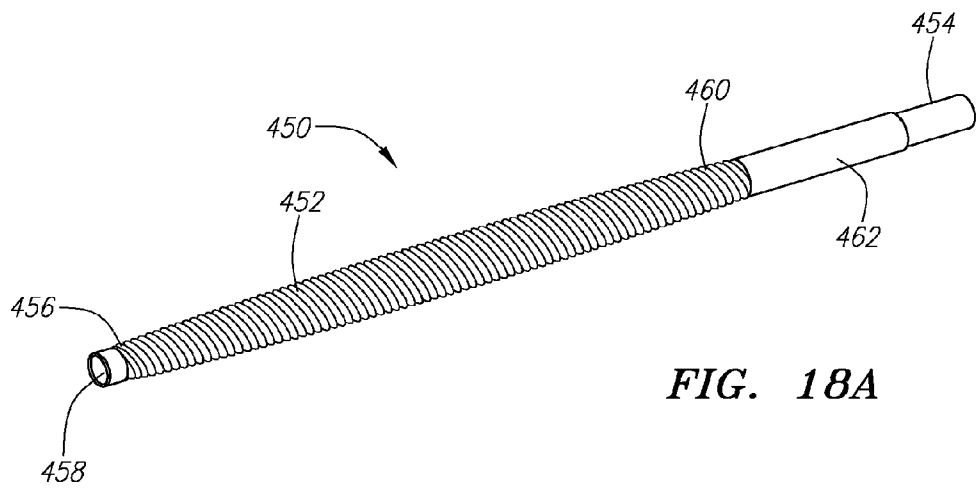

FIG. 16B





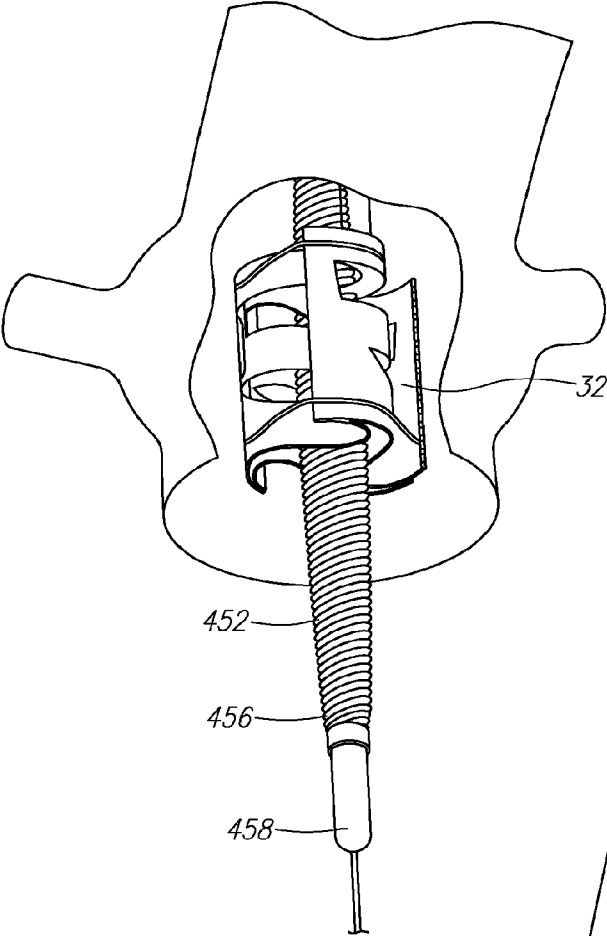

FIG. 18C

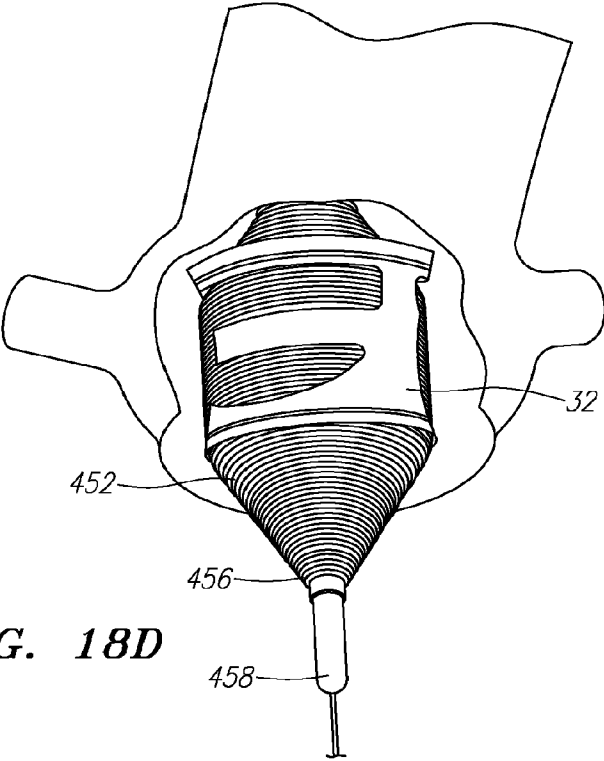

FIG. 18D

**PROSTHETIC HEART VALVES,
SCAFFOLDING STRUCTURES, AND
SYSTEMS AND METHODS FOR
IMPLANTING OF SAME**

**CROSS REFERENCE TO RELATED
APPLICATIONS**

[0001] This application is a continuation of U.S. application Ser. No. 11/066,126, filed Feb. 25, 2005, which claims the benefit of U.S. Provisional Application Ser. No. 60/548,731, filed Feb. 27, 2004, and U.S. Provisional Application Ser. No. 60/559,199, filed Apr. 1, 2004, all of which applications are hereby incorporated by reference in their entirety.

FIELD OF THE INVENTION

[0002] The present invention relates generally to medical devices and methods. More particularly, the present invention relates to prosthetic heart valves, structures for providing scaffolding of body lumens, and devices and methods for delivering and deploying these valves and structures.

BACKGROUND OF THE INVENTION

[0003] Diseases and other disorders of the heart valve affect the proper flow of blood from the heart. Two categories of heart valve disease are stenosis and incompetence. Stenosis refers to a failure of the valve to open fully, due to stiffened valve tissue. Incompetence refers to valves that cause inefficient blood circulation by permitting backflow of blood in the heart.

[0004] Medication may be used to treat some heart valve disorders, but many cases require replacement of the native valve with a prosthetic heart valve. Prosthetic heart valves can be used to replace any of the native heart valves (aortic, mitral, tricuspid or pulmonary), although repair or replacement of the aortic or mitral valves is most common because they reside in the left side of the heart where pressures are the greatest. Two primary types of prosthetic heart valves are commonly used, mechanical heart valves and prosthetic tissue heart valves.

[0005] The caged ball design is one of the early mechanical heart valves. The caged ball design uses a small ball that is held in place by a welded metal cage. In the mid-1960s, another prosthetic valve was designed that used a tilting disc to better mimic the natural patterns of blood flow. The tilting-disc valves had a polymer disc held in place by two welded struts. The bileaflet valve was introduced in the late 1970s. It included two semicircular leaflets that pivot on hinges. The leaflets swing open completely, parallel to the direction of the blood flow. They do not close completely, which allows some backflow.

[0006] The main advantages of mechanical valves are their high durability. Mechanical heart valves are placed in young patients because they typically last for the lifetime of the patient. The main problem with all mechanical valves is the increased risk of blood clotting.

[0007] Prosthetic tissue valves include human tissue valves and animal tissue valves. Both types are often referred to as bioprosthetic valves. The design of bioprosthetic valves are closer to the design of the natural valve. Bioprosthetic valves do not require long-term anticoagulants, have better hemodynamics, do not cause damage to blood cells, and do not suffer from many of the structural problems experienced by the mechanical heart valves.

[0008] Human tissue valves include homografts, which are valves that are transplanted from another human being, and autografts, which are valves that are transplanted from one position to another within the same person.

[0009] Animal tissue valves are most often heart tissues recovered from animals. The recovered tissues are typically stiffened by a tanning solution, most often glutaraldehyde. The most commonly used animal tissues are porcine, bovine, and equine pericardial tissue.

[0010] The animal tissue valves are typically stented valves. Stentless valves are made by removing the entire aortic root and adjacent aorta as a block, usually from a pig. The coronary arteries are tied off, and the entire section is trimmed and then implanted into the patient.

[0011] A conventional heart valve replacement surgery involves accessing the heart in the patient's thoracic cavity through a longitudinal incision in the chest. For example, a median sternotomy requires cutting through the sternum and forcing the two opposing halves of the rib cage to be spread apart, allowing access to the thoracic cavity and heart within. The patient is then placed on cardiopulmonary bypass which involves stopping the heart to permit access to the internal chambers. Such open heart surgery is particularly invasive and involves a lengthy and difficult recovery period.

[0012] A less invasive approach to valve replacement is desired. The percutaneous implantation of a prosthetic valve is a preferred procedure because the operation is performed under local anesthesia, does not require cardiopulmonary bypass, and is less traumatic. Current attempts to provide such a device generally involve stent-like structures, which are very similar to those used in vascular stent procedures with the exception of being larger diameter as required for the aortic anatomy, as well as having leaflets attached to provide one way blood flow. These stent structures are radially contracted for delivery to the intended site, and then expanded/deployed to achieve a tubular structure in the annulus. The stent structure needs to provide two primary functions. First, the structure needs to provide adequate radial stiffness when in the expanded state. Radial stiffness is required to maintain the cylindrical shape of the structure, which assures the leaflets coapt properly. Proper leaflet coaption assures the edges of the leaflets mate properly, which is necessary for proper sealing without leaks. Radial stiffness also assures that there will be no paravalvular leakage, which is leaking between the valve and aorta interface, rather than through the leaflets. An additional need for radial stiffness is to provide sufficient interaction between the valve and native aortic wall that there will be no valve migration as the valve closes and holds full body blood pressure. This is a requirement that other vascular devices are not subjected to. The second primary function of the stent structure is the ability to be crimped to a reduced size for implantation.

[0013] Prior devices have utilized traditional stenting designs which are produced from tubing or wire wound structures. Although this type of design can provide for crimpability, it provides little radial stiffness. These devices are subject to "radial recoil" in that when the device is deployed, typically with balloon expansion, the final deployed diameter is smaller than the diameter the balloon and stent structure were expanded to. The recoil is due in part because of the stiffness mismatches between the device and the anatomical environment in which it is placed. These devices also commonly cause crushing, tearing, or other deformation to the valve leaflets during the contraction and expansion proce-

dures. Other stenting designs have included spirally wound metallic sheets. This type of design provides high radial stiffness, yet crimping results in large material strains that can cause stress fractures and extremely large amounts of stored energy in the constrained state. Replacement heart valves are expected to survive for many years when implanted. A heart valve sees approximately 500,000,000 cycles over the course of 15 years. High stress states during crimping can reduce the fatigue life of the device. Still other devices have included tubing, wire wound structures, or spirally wound sheets formed of nitinol or other superelastic or shape memory material. These devices suffer from some of the same deficiencies as those described above. The scaffolding structures and prosthetic valves described herein address both attributes of high radial stiffness along with crimpability, and maximizing fatigue life.

SUMMARY OF THE INVENTION

[0014] The present invention provides apparatus and methods for deploying support structures in body lumens. The methods and apparatus are particularly adapted for use in percutaneous aortic valve replacement. The methods and apparatus may also find use in the peripheral vasculature, the abdominal vasculature, and in other ducts such as the biliary duct, the fallopian tubes, and similar lumen structures within the body of a patient. Although particularly adapted for use in lumens found in the human body, the apparatus and methods may also find application in the treatment of animals.

[0015] In one aspect of the invention, a prosthetic valve is provided. The prosthetic valve includes a support member and a valvular body attached to the support member. The prosthetic valve has an expanded state in which the support member has a cross-sectional shape that is generally cylindrical or generally oval and which has a first cross-sectional dimension (e.g., diameter), and a contracted state in which the support member has a second cross-sectional dimension (e.g., diameter) smaller than the first. The prosthetic valve is in its contracted state during delivery of the prosthetic valve to a treatment location, and in its expanded state after deployment at the treatment location. Preferably, the cross-sectional dimension of the support member in its expanded state is sufficiently large, and the support member possesses sufficient radial strength, to cause the support member to positively physically engage the internal surface of the body lumen, such as the aortic valve annulus or another biologically acceptable aortic position (e.g., a location in the ascending or descending aorta), thereby providing a strong friction fit.

[0016] Specifically, in several preferred embodiments, the support member has a cross-sectional dimension that is slightly larger than the dimension of the treatment location, such as a body lumen. For example, if the treatment location is the root annulus of the aortic valve, the support member may be provided with a cross-sectional dimension that is from about 0 to about 25% larger than the cross-sectional dimension of the valve annulus. Cross-sectional dimensions even larger than 25% greater than that of the body lumen may also be used, depending upon the nature of the treatment location. As described in more detail below, once deployed, the support member extends to its full cross-sectional dimension—i.e., it does not compress radially due to the radial force imparted by the lumen or other tissue. Rather, the support member will expand the cross-sectional dimension of the lumen or other tissue at the treatment location. In this way, the support mem-

ber reduces the possibility of fluid leakage around the periphery of the device. In addition, due to the strength of the interference fit that results from the construction of the device, the support member will have proper apposition to the lumen or tissue to reduce the likelihood of migration of the device once deployed.

[0017] In several embodiments, the support member is a structure having at least two peripheral segments, at least two of which segments are connected to each other by a foldable junction. As used herein, the term “segment” refers to a constituent part into which the support member is divided by foldable junctions or other junctions connecting adjacent segments. In several embodiments, each segment comprises a panel, with two or more connected panels making up the support member. Alternatively, and without intending to otherwise limit the descriptions provided, segments may comprise beams, braces, struts, or other structural members extending between the foldable junctions provided on the support member. Any of these (or any other) alternative structures, or any combinations thereof, may be provided as one or more segments of the support member.

[0018] In the above embodiments of the support member, the foldable junction may comprise any structural member that allows two adjacent segments to partially or completely fold one upon another. In several preferred embodiments, the foldable junction comprises a hinge. Suitable hinges include mechanical hinges, membrane hinges, living hinges, or combinations of such hinges.

[0019] In addition to the foldable junctions, two adjacent panels may be connectable by a selectively locking junction, such as pairs of opposed tabs and slots. In embodiments that include three or more segments, a combination of foldable junctions and locking junctions may be used.

[0020] The support structure may be provided with one or more anchoring members that are adapted to engage the internal wall of the body lumen. Each anchoring member may comprise a barb, a tooth, a hook, or any other member that protrudes from the external surface of the support structure to physically engage the internal wall of the body lumen. Alternatively, the anchoring member may comprise an aperture formed in the support structure that allows tissue to invaginate therethrough, i.e., the outward radial force of the support member against the vessel wall causes the frame portion of the support member to slightly embed into the vessel wall, thereby causing some of the tissue to penetrate through the aperture into the interior of the support member. The tissue invagination acts to anchor the support structure in place. An anchoring member may be selectively engageable, such as by an actuator, or it may be oriented so as to be permanently engaged. Alternatively, the anchoring member may be self-actuating, or it may be deployed automatically during deployment of the support member.

[0021] The anchoring member advantageously may perform functions in addition to engaging the internal wall of the body lumen. For example, the anchoring member may ensure proper positioning of the support structure within the body lumen. It may also prevent migration or other movement of the support structure, and it may provide additional or enhanced sealing of the support structure to the body lumen, such as by creating better tissue adherence.

[0022] The support structure may also be provided with an optional sealing member, such as a gasket. The sealing member preferably is fixed to the external surface of the support structure around all or a portion of the circumference of the

support structure, and serves to decrease or eliminate the flow of fluids between the vessel wall and the support member. The sealing member may comprise a relatively soft biocompatible material, such as a polyurethane or other polymer. Preferably, the sealing member is porous or is otherwise capable of expanding or swelling when exposed to fluids, thereby enhancing the sealing ability of the sealing member. The sealing member may include a functional composition such as an adhesive, a fixative, or therapeutic agents such as drugs or other materials.

[0023] As an additional option, a coating may be applied to or created on any of the surfaces of the support member. Coatings may be applied or created to provide any desired function. For example, a coating may be applied to carry an adhesive, a fixative, or therapeutic agents such as drugs or other materials. Coatings may be created on the external surface of the support member to facilitate tissue penetration (e.g., ingrowth) into the support structure. Coatings may also be provided to promote sealing between the support member and the native tissue, or to reduce the possibility that the support member may migrate from its intended location. Other coating functions will be recognized by those skilled in the art.

[0024] The valvular body may be of a single or multi-piece construction, and includes a plurality of leaflets. The valvular body may be attached either to the internal or external surface of the support structure. In the case of a single-piece construction, the valvular body includes a base portion that is attachable to the support structure, and a plurality of (and preferably three) leaflets extending from the base portion. In the case of a multi-piece construction, the valvular body includes a plurality of (preferably three) members, each including a base portion that is attachable to the support structure and a leaflet portion. In either case, the base portion(s) of the valvular body are attached to a portion of the internal or external surface of the support structure, and the leaflets extend away from the base portion and generally inwardly toward each other to form the valve.

[0025] The valvular body, either single-piece or multi-piece, may comprise a homogeneous material, for example, a polymer such as polyurethane or other suitable elastomeric material. Alternatively, the valvular body may comprise a coated substrate, wherein the substrate comprises a polymer (e.g., polyester) or metallic (e.g., stainless steel) mesh, and the coating comprises a polymer such as polyurethane or other suitable elastomeric material. Other suitable constructions are also possible.

[0026] Alternatively, the valvular body may comprise human (including homograft or autograft) or animal (e.g., porcine, bovine, equine, or other) tissue.

[0027] The valvular body may be attached to the support structure by any suitable mechanism. For example, an attachment lip formed of a polymer, fabric, or other flexible material may be molded or adhered to the surface of the support member, and the valvular body sewn, adhered, or molded onto the attachment lip. Alternatively, an edge portion of the valvular body may be sandwiched between a pair of elastomeric strips that are attached to the surface of the support member. Other and further attachment mechanisms may also be used.

[0028] As described above, each of the foregoing embodiments of the prosthetic valve preferably has a fully expanded state for deployment within a body lumen, and a contracted state for delivery to the lumen in a minimally invasive inter-

ventional procedure through the patient's vasculature. In the fully expanded state, each of the segments of the support member is oriented peripherally and adjacent to one another, attached to each adjacent segment by a foldable junction or a locking junction. In the contracted state, the segments are folded together at the foldable junctions and, preferably, then formed into a smaller diameter tubular structure. The contracted state may be achieved in different combinations and manners of folding and rolling the segments and junctions, depending on the particular structure of the prosthetic valve.

[0029] For example, in one embodiment, the prosthetic valve comprises a generally cylindrical support member made up of three panels, with each panel connected to its adjacent panel by a hinge. The hinges may be mechanical hinges, membrane hinges, living hinges, or a combination of such hinges. In its fully expanded state, each panel of the prosthetic valve is an arcuate member that occupies approximately 120°, or one third, of the circular cross-section of the cylindrical support member. Alternatively, one or more of the panels may span a smaller portion of the cylindrical support member, while the other panel(s) are relatively larger. For example, a relatively shorter panel may be provided on a side of the valve corresponding to the non-coronary native valve leaflet, which is generally smaller than the other native valve leaflets. A valvular body is attached to the internal surface of each of the three panels. The contracted state is obtained by first inverting each of the panels at its centerline, i.e., changing each panel from a convex shape to a concave shape by bringing the centerline of each panel toward the longitudinal axis running through the center of the generally cylindrical support member. This action causes the foldable junctions to fold, creating a vertex at each foldable junction. For the foregoing three panel support member, a three vertex star-shaped structure results. In the case of a four panel support member, a four vertex star-shaped structure would result. The valvular body, which is formed of generally flexible, resilient materials, generally follows the manipulations of the support member without any substantial crimping, tearing, or permanent deformation.

[0030] Inversion of the panels results in a structure having a relatively smaller maximum transverse dimension than that of the fully expanded structure. To further reduce the transverse dimension, each vertex is curled back toward the central axis to create a plurality of lobes equi-spaced about the central axis, i.e., in the three-panel structure, three lobes are formed. The resulting multi-lobe structure has an even further reduced maximum transverse dimension, and represents one embodiment of the contracted state of the prosthetic valve.

[0031] In another embodiment, the prosthetic valve comprises a generally cylindrical support member made up of three panels defining three junctions, two of which comprise hinges, and one of which comprises a set of locking tabs and slots. The hinges may be mechanical hinges, membrane hinges, living hinges, other hinge types, or a combination of such hinges. As with the prior embodiment, in its fully expanded state, each panel of the prosthetic valve is an arcuate member that occupies approximately 120°, or one third, of the circular cross-section of the cylindrical support member. A valvular body is attached to the internal surface of each of the three panels, with at least one separation in the valvular body corresponding with the location of the locking junction on the support member. The contracted state in this alternative embodiment is obtained by first isengaging the locking tabs and slots at the non-hinge junction between a first two of the

panels. Alternatively, the locking tabs and slots may be simply unlocked to permit relative motion while remaining slidably engaged. The third panel, opposite the non-hinge junction, is then inverted, i.e., changed from convex to concave by bringing the centerline of the panel toward the longitudinal axis running through the center of the generally cylindrical support member. The other two panels are then nested behind the third panel, each retaining its concave shape, by rotating the hinges connecting each panel to the third panel. The resulting structure is a curved-panel shaped member. The valvular body, which is formed of generally flexible, resilient materials, generally follows the manipulations of the support member without any substantial crimping, tearing, or permanent deformation. The structure is then curled into a tubular structure having a relatively small diameter in relation to that of the fully expanded prosthetic valve, and which represents an alternative embodiment of the contracted state of the prosthetic valve.

[0032] In still another embodiment, the prosthetic valve comprises a generally oval-shaped support member made up of two panels, with a hinge provided at the two attachment edges between the panels. The hinges may be mechanical hinges, membrane hinges, living hinges, or a combination of such hinges. A valvular body is attached to the internal surface of each of the two panels. The contracted state is obtained by first inverting one of the two panels at its centerline, i.e., changing the panel from a convex shape to a concave shape by bringing the centerline of the panel toward the longitudinal axis running through the center of the generally oval support member. This action causes the foldable junctions to fold, creating a vertex at each foldable junction, and causes the two panels to come to a nested position. The valvular body, which is formed of generally flexible, resilient materials, generally follows the manipulations of the support member without any substantial crimping, tearing, or permanent deformation. The structure is then curled into a tubular structure having a relatively small diameter in relation to that of the fully expanded prosthetic valve, and which represents another alternative embodiment of the contracted state of the prosthetic valve.

[0033] Several alternative support members are also provided. In one such alternative embodiment, the support structure is a generally tubular member constructed such that it is capable of transforming from a contracted state having a relatively small diameter and large length, to an expanded state having a relatively large diameter and small length. The transformation from the contracted state to the expanded state entails causing the tubular member to foreshorten in length while expanding radially. The forced foreshortening transformation may be achieved using any of a wide range of structural components and/or methods. In a particularly preferred form, the support structure comprises an axially activated support member. The axially activated support member includes a generally tubular body member formed of a matrix of flexible struts. In one embodiment, struts are arranged in crossing pairs forming an "X" pattern, with the ends of a first crossing pair of struts being connected to the ends of a second crossing pair of struts by a band connector, thereby forming a generally cylindrical member. Additional generally cylindrical members may be incorporated into the structure by interweaving the struts contained in the additional cylindrical member with one or more of the struts included in the first cylindrical member. An axial member is connected to at least two opposed band connectors located on opposite ends of the structure. When the axial member is decreased in length, the

support member is expanded to a large diameter state, accompanied by a degree of foreshortening of the support member. When the axial member is increased in length, the support member is contracted to a smaller diameter state, accompanied by a degree of lengthening of the support member. The expanded state may be used when the support member is deployed in a body lumen, and the contracted state may be used for delivery of the device. A valvular body, as described above, may be attached to the internal or external surface of the support member.

[0034] In the foregoing embodiment, the axial member may be replaced by a circumferential member, a spirally wound member, or any other structure adapted to cause the tubular member to foreshorten and thereby to transform to the expanded state. The axial or other member may be attached to opposed connectors, to connectors that are not opposed, or connectors may not be used at all. Alternatively, the support member may be formed of a plurality of braided wires or a single wire formed into a tubular shape by wrapping around a mandrel. In either case, the structure is caused to radially expand by inducing foreshortening.

[0035] As a further alternative, the support structure (or portions thereof) may be self-expanding, such as by being formed of a resilient or shape memory material that is adapted to transition from a relatively long tubular member having a relatively small cross-sectional dimension to a relatively shorter tubular member having a relatively larger cross-sectional dimension. In yet further alternatives, the support structure may partially self-expand by foreshortening, after which an expansion device may be used to cause further radial expansion and longitudinal foreshortening.

[0036] In another alternative embodiment, the support member comprises a multiple panel hinged ring structure. The multiple panel hinged ring structure includes a plurality of (preferably three) circumferential rings interconnected by one or more (preferably three) longitudinal posts. Each ring structure, in turn, is composed of a plurality of segments, such as curved panels, each connected to its adjacent panels by a junction member, such as a polymeric membrane hinge. The hinges are rotated to transform the structure from an expanded state for deployment, to a contracted state for delivery. A valvular body, as described elsewhere herein, is attached to the internal or external surface of the support member.

[0037] In still another alternative embodiment, the support member comprises a collapsing hinged structure. The collapsing hinged structure includes a plurality of (preferably about twenty-four) panels arranged peripherally around the generally tubular structure, each panel having a tab on its edge that overlaps and engages a mating tab on the opposed edge of the adjacent panel, interlocking the adjacent panels. An elastic membrane is attached to an external surface of adjacent panels and provides a force biasing the adjacent panels together to assist the tabs in interlocking each adjacent pair of panels. Preferably, the elastic membrane is attached to the main body of each panel, but not at the opposed edges. Thus, the tabs may be disengaged and the panels rotated to form a vertex at each shared edge, thereby defining a multi-vertex "star" shape that corresponds with the contracted state of the support member. The support member is transformed to its expanded state by applying an outward radial force that stretches the elastic membrane and allows the tabs to re-

engage. A valvular body, as described elsewhere herein, is attached to the internal or external surface of the support member.

[0038] The various support members may be incorporated in a prosthetic valve, as described above, by attaching a valvular body to the external or internal surface of the support member. In the alternative, any of the foregoing support members may be utilized without a valvular body to provide a support or scaffolding function within a body lumen, such as a blood vessel or other organ. For example, the multi-segment, multi-hinged support member may be used as a scaffolding member for the treatment of abdominal aortic aneurisms, either alone, or in combination with another support member, graft, or other therapeutic device. Other similar uses are also contemplated, as will be understood by those skilled in the art.

[0039] Each of the foregoing prosthetic valves and support members is adapted to be transformed from its expanded state to its contracted state to be carried by a delivery catheter to a treatment location by way of a minimally invasive interventional procedure, as described more fully elsewhere herein.

[0040] In other aspects of the invention, delivery devices for delivering a prosthetic valve to a treatment location in a body lumen are provided, as are methods for their use. The delivery devices are particularly adapted for use in minimally invasive interventional procedures, such as percutaneous aortic valve replacements. The delivery devices include an elongated delivery catheter having proximal and distal ends. A handle is provided at the proximal end of the delivery catheter. The handle may be provided with a knob, an actuator, a slider, other control members, or combinations thereof for controlling and manipulating the catheter to perform the prosthetic valve delivery procedure. A retractable outer sheath may extend over at least a portion of the length of the catheter. Preferably, a guidewire lumen extends proximally from the distal end of the catheter. The guidewire lumen may extend through the entire length of the catheter for over-the-wire applications, or the guidewire lumen may have a proximal exit port closer to the distal end of the catheter than the proximal end for use with rapid-exchange applications.

[0041] The distal portion of the catheter includes a carrier adapted to receive and retain a prosthetic valve and to maintain the prosthetic valve in a contracted state, and to deploy the prosthetic valve at a treatment location within a body lumen. In one embodiment, the distal portion of the catheter is provided with a delivery tube having a plurality of longitudinal slots at its distal end, and a gripper having a longitudinal shaft and a plurality of fingers that extend longitudinally from the distal end of the gripper. Preferably, the delivery tube has the same number of longitudinal slots, and the gripper includes the same number of fingers, as there are segments on the prosthetic valve to be delivered. The longitudinal slots on the distal end of the delivery tube are equally spaced around the periphery of the tube. Similarly, as viewed from the distal end of the gripper, the fingers are arranged in a generally circular pattern. For example, in the case of three fingers, all three are spaced apart on an imaginary circle and are separated from each other by approximately 120°. In the case of four fingers, the fingers are separated from each other by approximately 90°, and so on. The spacing and orientation of the longitudinal slots and fingers may vary from these preferred values while still being sufficient to perform the delivery function in the manner described herein. The gripper is slidably and rotatably received within the delivery tube, and

the delivery tube is internal of the outer sheath. The outer sheath is retractable to expose at least the longitudinal slots on the distal portion of the delivery tube. The gripper is able to be advanced at least far enough to extend the fingers distally outside the distal end of the delivery tube.

[0042] In alternative embodiments of the above delivery device, the gripper fingers may comprise wires, fibers, hooks, sleeves, other structural members extending distally from the distal end of the gripper, or combinations of any of the foregoing. As described below, a primary function of the fingers is to retain a prosthetic valve on the distal end of the gripper, and to restrain segments of the support member of the valve in an inverted state. Accordingly, any of the above (or other) structural members able to perform the above function may be substituted for the fingers described above.

[0043] An optional atraumatic tip or nosecone may be provided at the distal end of the device. The tip is preferably formed of a relatively soft, elastomeric material and has a rounded to conical shape. A central lumen is provided in the tip to allow passage of the guidewire. The shape and physical properties of the tip enhance the ability of the delivery device to safely pass through the vasculature of a patient without damaging vessel walls or other portions of the anatomy. In addition, the atraumatic tip may enhance the ability of the distal portion of the device to cross the native heart valve when the leaflets of the native valve are fully or partially closed due to calcification from disease or other disorder.

[0044] The delivery device is particularly adapted for use in a minimally invasive surgical procedure to deliver a multi-segment prosthetic valve, such as those described above, to a body lumen. To do so, the prosthetic valve is first loaded into the delivery device. In the case of a prosthetic valve having a three segment support member, the delivery tube will have three longitudinal slots at its distal end, and the gripper will be provided with three fingers. The prosthetic valve is loaded into the delivery device by first inverting the three segments to produce a three vertex structure. Inverting of the prosthetic valve segments may be performed manually, or with the aid of a tool. The prosthetic valve is then placed onto the distal end of the gripper, which has been previously extended outside the distal end of the delivery tube, with each of the three fingers retaining one of the inverted segments in its inverted position. The gripper and fingers, with the prosthetic valve installed thereon, are then retracted back into the delivery tube. During the retraction, the gripper and fingers are rotationally aligned with the delivery tube such that the three vertices of the prosthetic valve align with the three longitudinal slots on the distal end of the delivery tube. When the gripper and fingers are fully retracted, each of the three vertices of the prosthetic valve extends radially outside the delivery tube through the longitudinal slots. The gripper is then rotated relative to the delivery tube (or the delivery tube rotated relative to the gripper), which action causes each of the folded segments of the prosthetic valve to engage an edge of its respective delivery tube slot. Further rotation of the gripper relative to the delivery tube causes the folded segments to curl back toward the longitudinal axis of the prosthetic valve internally of the delivery tube, creating three lobes located fully within the delivery tube. The prosthetic valve is thereby loaded into the delivery device. The outer sheath may then be advanced over the distal portion of the catheter, including the delivery tube, to prepare the delivery device for use.

[0045] The prosthetic valve is delivered by first introducing a guidewire into the vascular system and to the treatment location of the patient by any conventional method, preferably by way of the femoral artery. Optionally, a suitable introducer sheath may be advanced to facilitate introduction of the delivery device. The delivery catheter is then advanced over the guidewire to the treatment location. The outer sheath is then retracted to expose the delivery tube. The gripper is then rotated relative to the delivery tube (or the delivery tube rotated relative to the gripper), thereby causing the folded segments of the prosthetic valve to uncurl and to extend radially outward through the longitudinal slots of the delivery tube. The delivery tube is then retracted (or the gripper advanced) to cause the prosthetic valve (restrained by the fingers) to advance distally out of the delivery tube. The gripper is then retracted relative to the prosthetic valve, releasing the prosthetic valve into the treatment location. Preferably, the inverted segments then revert to the expanded state, causing the valve to lodge against the internal surface of the body lumen (e.g., the aortic valve root or another biologically acceptable aortic position). Additional expansion of the prosthetic valve may be provided, if needed, by a suitable expansion member, such as an expansion balloon or an expanding mesh member (described elsewhere herein), carried on the delivery catheter or other carrier.

[0046] In another embodiment of the delivery device, the distal portion of the catheter includes a restraining sheath, an orientation sheath, a plurality of grippers, an expander, and a plurality of struts. An optional atraumatic tip or nosecone, as described above, may also be fixed to the distal end of the device. Each of the grippers includes a wire riding within a tube, and a tip at the distal end of the tube. The wire of each gripper is adapted to engage the vertex of a prosthetic valve support member having multiple segments, and to selectively restrain the prosthetic valve in a contracted state. The expander is adapted to selectively cause the grippers to expand radially outwardly when it is actuated by the user by way of an actuator located on the handle.

[0047] The prosthetic valve may be loaded into the delivery device by contracting the prosthetic valve (either manually or with a tool) by inverting each panel and then attaching each vertex to a respective gripper on the delivery device. The grippers receive, retain, and restrain the prosthetic valve in its contracted state. The gripper assembly having the prosthetic valve installed is then retracted into each of the orientation sheath and the restraining sheath to prepare the device for insertion into the patient's vasculature. The device is then advanced over a guidewire to a treatment location, such as the base annulus of the native aortic valve or another biologically acceptable aortic position (e.g., a location in the ascending or descending aorta). The restraining sheath is then retracted to allow the prosthetic valve to partially expand (e.g., to about 85% of its full transverse dimension), where it is constrained by the orientation sheath. The prosthetic valve is then finally positioned by manipulation of the grippers, after which the orientation sheath is retracted and the grippers released. The prosthetic valve then is fixedly engaged in the treatment location.

[0048] In yet another embodiment of the delivery device, the distal portion of the catheter includes one or more restraining tubes having at least one (and preferably two) adjustable restraining loops. The restraining tube(s) extend distally from a catheter shaft out of the distal end of the delivery device, and each restraining loop is a wire or fiber loop that extends

transversely from the restraining tube. Each restraining loop is a flexible loop capable of selectively restraining a contracted prosthetic valve. The restraining loop may be selectively constricted or released by a control member, such as a knob, located on the handle of the device, or by another external actuation member. An optional retractable outer sheath may be provided to cover the distal portion of the catheter. Additionally, an optional atraumatic tip or nosecone, as described above, may be provided at the distal end of the device.

[0049] The prosthetic valve may be loaded onto the delivery device by contracting the prosthetic valve (either manually or with a tool) into its contracted state, for example, by inverting each panel and curling each inverted panel into a lobe. The contracted prosthetic valve is then placed onto the restraining tube(s) and through the one or more restraining loops. The loops are constricted around the contracted prosthetic valve, thereby restraining the prosthetic valve in its contracted state. The optional outer sheath may then be advanced over the prosthetic valve and the restraining tube(s) to prepare the delivery device for use. The device is then advanced over a guidewire to a treatment location, such as the base annulus of the native aortic valve or another biologically acceptable aortic position (e.g., a location in the ascending or descending aorta). The restraining sheath is then retracted to expose the contracted prosthetic valve. The restraining loops are released, such as by rotating the control knob, thereby releasing the prosthetic valve and allowing it to self-expand. The prosthetic valve is thereby fixedly engaged in the treatment location. An expansion member may be advanced to the interior of the prosthetic valve (or retracted from distally of the valve) and expanded to provide additional expansion force, if needed or desired.

[0050] In each of the foregoing device delivery methods, the user is able to deploy the device in a careful, controlled, and deliberate manner. This allows the user to, among other things, pause the delivery procedure and reposition the device if needed to optimize the delivery location. This added degree of control is a feature that is not available in many of the previous percutaneous device delivery methods.

[0051] In another aspect of the invention, an expansion member is provided for performing dilation functions in minimally invasive surgical procedures. For example, the expansion member may be used in procedures such as angioplasty, valvuloplasty, stent or other device placement or expansion, and other similar procedures. In relation to the devices and methods described above and elsewhere herein, the expansion member may be used to provide additional expansion force to the support members used on the prosthetic valves described herein.

[0052] In one embodiment, the expansion member comprises a plurality of inflation balloons oriented about a longitudinal axis. Each inflation balloon is connected at its proximal end by a feeder lumen to a central lumen that provides fluid communication between the inflation balloons and a source of inflation media associated with a handle portion of a catheter. The central lumen itself is provided with a guidewire lumen to allow passage of a guidewire through the expansion member. A flexible member is attached to the distal end of each of the inflation balloons, and also includes a guidewire lumen. In a preferred embodiment, the expansion member includes three inflation balloons, although fewer or more balloons are possible. The balloons may each be inflated individually, all together, or in any combination to obtain a

desired force distribution. The multiple inflation balloon structure provides a number of advantages, including the ability to provide greater radial forces than a single balloon, and the ability to avoid occluding a vessel undergoing treatment and to allow blood or other fluid to flow through the device.

[0053] In an alternative embodiment, the expansion member comprises a flexible, expandable mesh member. The expandable mesh member includes a shaft and a cylindrical woven mesh member disposed longitudinally over the shaft. A distal end of the cylindrical mesh member is attached to the distal end of the shaft. The proximal end of the cylindrical mesh member is slidably engaged to the shaft by a collar proximally of the distal end. As the collar is advanced distally along the shaft, the body of the cylindrical mesh member is caused to expand radially, thereby providing a radially expansion member. Alternatively, the proximal end of the mesh member may be fixed to the shaft and the distal end may have a collar engagement allowing it to advance proximally along the shaft to cause the mesh member to expand radially. Still further, each of the proximal and distal ends of the mesh member may be slidably engaged to the shaft, and each moved toward the other to cause radial expansion.

[0054] Other aspects, features, and functions of the inventions described herein will become apparent by reference to the drawings and the detailed description of the preferred embodiments set forth below.

DESCRIPTION OF THE DRAWINGS

- [0055] FIG. 1A is a perspective view of a prosthetic valve in accordance with the present invention.
- [0056] FIG. 1B is a perspective view of a support member in accordance with the present invention.
- [0057] FIG. 2A is a perspective view of a support member having illustrating inverted panels.
- [0058] FIG. 2B is a top view of the support member of FIG. 2A.
- [0059] FIG. 2C is a top view of a support member in a contracted state.
- [0060] FIG. 3A is a perspective view of another support member in accordance with the present invention.
- [0061] FIG. 3B is a close-up view of a hinge on the support member of FIG. 3A.
- [0062] FIG. 3C is a close-up view of an locking tab and slot on the support member of FIG. 3A.
- [0063] FIG. 3D is a perspective view of the support member shown in FIG. 3A, illustrating inversion of a panel.
- [0064] FIG. 3E is a perspective view of the support member shown in FIG. 3A, illustrating a nested arrangement of the three panels.
- [0065] FIG. 3F is a perspective view of the support member shown in FIG. 3A, illustrating a contracted state of the support member.
- [0066] FIG. 3G is an end view of the support member shown in FIG. 3A, illustrating a contracted state of the support member.
- [0067] FIG. 3H is a top view of another support member, illustrating a nested arrangement of the three panels.
- [0068] FIG. 3I is a side view of the support member shown in FIG. 3H.
- [0069] FIG. 4A is a perspective view illustrating a hinge connecting two panels of a support member.
- [0070] FIG. 4B is a perspective view of the hinge shown in FIG. 4A, illustrating the hinge in its folded state.
- [0071] FIG. 4C is a perspective view of another hinge connecting two panels of a support member.
- [0072] FIG. 4D is a perspective view of another hinge connecting two panels of a support member.
- [0073] FIG. 5A is a perspective view of a support member having inverted panels, illustrating removable hinge pins.
- [0074] FIG. 5B is a perspective view of a support member after separation of its three panels.
- [0075] FIG. 6 is a perspective view of another support member.
- [0076] FIG. 7 is a close-up view of an attachment mechanism for attaching a valvular body to a support member.
- [0077] FIG. 8A is a perspective view of a valvular body.
- [0078] FIG. 8B is a perspective view showing separate leaflets of the valvular body of FIG. 8A.
- [0079] FIG. 9A is a perspective view of an axially activated support member in its contracted state.
- [0080] FIG. 9B is a perspective view of the axially activated support member of FIG. 9A, shown in its expanded state.
- [0081] FIG. 10A is a perspective view of a multiple panel hinged ring prosthetic valve.
- [0082] FIG. 10B is an end view of the prosthetic valve shown in FIG. 10A.
- [0083] FIG. 10C is a perspective view of a multiple panel hinged ring support member.
- [0084] FIG. 10D is an end view of the support member shown in FIG. 10C.
- [0085] FIG. 10E is a close-up view of a panel contained on the support member shown in FIG. 10C.
- [0086] FIG. 10F is a perspective view of a portion of a ring of panels contained on the support member shown in FIG. 10C.
- [0087] FIG. 10G is a top view of a ring of panels contained on a support member, shown in a contracted state.
- [0088] FIG. 10H is a perspective view of the support member shown in FIG. 10C, shown in the contracted state.
- [0089] FIG. 10I is a top view of a ring of panels contained on another support member, shown in a contracted state.
- [0090] FIG. 10J is a perspective view of the support member shown in FIG. 10I, shown in the contracted state.
- [0091] FIG. 11A is a perspective view of a collapsing hinged support member, shown in its expanded state.
- [0092] FIG. 11B is a perspective view of the collapsing hinged support member, shown in its contracted state.
- [0093] FIG. 11C is a close-up view of a portion of the collapsing hinged support member shown in FIG. 11A.
- [0094] FIG. 12A is a perspective view of a prosthetic valve retained on a delivery device.
- [0095] FIG. 12B is a top view of the prosthetic valve and delivery device shown in FIG. 12A.
- [0096] FIG. 12C is a side view of the prosthetic valve and delivery device shown in FIG. 12A.
- [0097] FIG. 12D is another top view of the prosthetic valve and delivery device shown in FIG. 12A.
- [0098] FIG. 12E is another top view the prosthetic valve and delivery device shown in FIG. 12A.
- [0099] FIG. 12F is another top view of the prosthetic valve and delivery device shown in FIG. 12A.
- [0100] FIG. 13A is a perspective view, shown in partial cross-section, of a prosthetic valve delivery device.
- [0101] FIG. 13B is a close-up view of a portion of the prosthetic valve delivery device shown in FIG. 13A.
- [0102] FIG. 13C is another close-up view of a portion of the prosthetic valve delivery device shown in FIG. 13A.

[0103] FIG. 13D is another perspective view, shown in partial cross-section, of the prosthetic valve delivery device shown in FIG. 13A.

[0104] FIG. 13E is an illustration showing the delivery device of FIG. 13A delivering a prosthetic valve to a treatment location.

[0105] FIG. 14A is a perspective view of another prosthetic valve delivery device.

[0106] FIG. 14B is a close-up view of a distal portion of the prosthetic valve delivery device shown in FIG. 14A.

[0107] FIG. 14C is another close-up view of the distal portion of the prosthetic valve delivery device shown in FIG. 14A.

[0108] FIG. 14D is an illustration showing the delivery device of FIG. 14A delivering a prosthetic valve to a treatment location.

[0109] FIG. 14E is another illustration showing the delivery device of FIG. 14A delivering a prosthetic valve to a treatment location.

[0110] FIG. 15A is a perspective view of another prosthetic valve delivery device.

[0111] FIG. 15B is a close-up view of a distal portion of the prosthetic valve delivery device shown in FIG. 15A.

[0112] FIG. 16A is a perspective view of another prosthetic valve delivery device.

[0113] FIG. 16B is another perspective view of the prosthetic valve delivery device shown in FIG. 16A.

[0114] FIG. 17A is a perspective view of a multi-balloon expansion device.

[0115] FIG. 17B is another perspective view of the multi-balloon expansion device shown in FIG. 17A.

[0116] FIG. 18A is a perspective view of an expandable mesh member, shown in its contracted state.

[0117] FIG. 18B is another perspective view of the expandable mesh member of FIG. 18A, shown in its expanded state.

[0118] FIG. 18C is an illustration showing the expandable mesh member being advanced into the interior space of a prosthetic valve.

[0119] FIG. 18D is another illustration showing the expandable mesh member being advanced into the interior space of a prosthetic valve.

DETAILED DESCRIPTION OF THE PREFERRED EMBODIMENTS

[0120] Before the present invention is described, it is to be understood that this invention is not limited to particular embodiments described, as such may, of course, vary. It is also to be understood that the terminology used herein is for the purpose of describing particular embodiments only, and is not intended to be limiting, since the scope of the present invention will be limited only by the appended claims.

[0121] Unless defined otherwise, all technical and scientific terms used herein have the same meaning as commonly understood by one of ordinary skill in the art to which these inventions belong. Although any methods and materials similar or equivalent to those described herein can also be used in the practice or testing of the present invention, the preferred methods and materials are now described. All publications mentioned herein are incorporated herein by reference to disclose and describe the methods and/or materials in connection with which the publications are cited.

[0122] It must be noted that as used herein and in the appended claims, the singular forms “a”, “an”, and “the” include plural referents unless the context clearly dictates otherwise.

[0123] The publications discussed herein are provided solely for their disclosure prior to the filing date of the present application. Nothing herein is to be construed as an admission that the present invention is not entitled to antedate such publication by virtue of prior invention. Further, the dates of publication provided may be different from the actual publication dates which may need to be independently confirmed.

[0124] As will be apparent to those of skill in the art upon reading this disclosure, each of the individual embodiments described and illustrated herein has discrete components and features which may be readily separated from or combined with the features of any of the other several embodiments without departing from the scope or spirit of the present inventions.

A. Prosthetic Valves and Related Apparatus

[0125] Turning first to FIG. 1A, an embodiment of a prosthetic valve is shown. The prosthetic valve 30 is particularly adapted for use as a replacement aortic valve, but may be used for other indications as well. As shown, the prosthetic valve 30 includes a generally cylindrical support member 32 and a valvular body 34 attached to the internal surface of the support member. Although a generally cylindrical support member is shown, support members having other than circular cross-sectional shapes, such as oval, elliptical, or irregular, may also be provided depending upon the nature of the treatment location and environment in which the prosthetic valve or the support structure are intended to be used.

[0126] The support member in the embodiment shown in FIG. 1A is made up of three generally identical curved panels 36, with each panel spanning approximately 120° of the circular cross-section of the support member. (As noted elsewhere herein, the panels need not be generally identical in terms of size, materials, thickness, or other properties.) Each panel 36 includes a frame 38 and a semi-circular aperture 40 extending over a large portion of the central portion of the panel. The aperture 40 includes a number of interconnecting braces 42 extending across the breadth of the aperture, thereby defining a number of sub-apertures 44 between the braces. The braces define several diamond-shaped sub-apertures 46, partial diamond-shaped sub-apertures 48, and an elongated sub-aperture 50. Apertures and sub-apertures of different 5 shapes and sizes than those shown in the FIG. 1A embodiment are also possible. For example, in the alternative support member embodiment shown in FIG. 1B, a single semi-circular aperture 40 is provided, with no braces and no sub-apertures. Alternatively, a panel may comprise a solid member having no apertures or sub-apertures.

[0127] The panels of the support member are typically the portion of the structure that engages the internal surface of the lumen at the treatment location. In the case of a prosthetic heart valve, among other functions, the panels physically engage and displace the leaflets of the native valve. The panels are also the primary portion of the structure that is in physical engagement with the body lumen and that is holding the structure in place and preventing migration. Therefore, the materials and structure of the panels are adapted, at least in part, to perform these functions. In some instances, a large aperture may be preferred, in other cases a particular bracing structure may be preferred, while in still other cases it is

preferable not to have any apertures or bracing. These features may be varied to provide desired performance, depending upon the anatomical environment.

[0128] Each of the panels shown, and those described elsewhere herein, is preferably formed from a sheet of resilient, biocompatible material, such as stainless steel, other metals or metal alloys, resilient polymers such as plastics, or other suitable materials conventionally used for implantable medical devices. In a preferred embodiment, the panels are formed from a super-elastic shape-memory material, such as nitinol or other similar metal alloys. The panels may be molded, extruded, etched, cut, stamped or otherwise fabricated from sheets of material, or manufactured in other ways known to those skilled in the art.

[0129] Although the support member embodiment shown in FIG. 1A includes three panels, those skilled in the art will recognize that fewer or more panels may be incorporated into the support member. For example, a two panel structure may be employed, or structures having four, five, or many more panels. Alternatively, a structure may be provided having non-panel segments, such as beams, braces, struts, or other structural members extending between the foldable junctions provided on the support member. Any of these (or any other) alternative structures, or any combinations thereof, may be provided as one or more segments of the support member, provided that the structure is capable of providing the physical and structural characteristics needed to support the prosthetic valve in its intended function.

[0130] In addition, although each of the segments making up a support member may be identical to the other segments, it is also possible to provide segments having different physical properties. For example, in a multi-panel support member, the panels may be made up of different materials, or one or more panels may have a different size or thickness than the other panel(s), or the physical properties between the different panels may be altered in some other manner. This may be done, for example, as an accommodation for the treatment location in which the prosthetic valve is to be placed. The wall thickness of the aortic root, for example, varies around its circumference. Thus, desirable results may be obtained by providing a support member having a first panel that provides greater structural strength (or resistance to collapse) than the other panels. Other variations are also possible.

[0131] Turning again to FIG. 1A, a hinge 52 is provided at the junction formed between each pair of adjacent panels. In the embodiment shown in FIG. 1A, the hinge is a membrane hinge comprising a thin sheet of elastomeric material 54 attached to the external edge 56 of each of a pair of adjacent panels 36. In the expanded state of the support member, as shown in FIG. 1A, the membrane hinge maintains the side-to-side orientation of each pair of adjacent panels, preventing any significant amount of slipping or sliding between the panels. As described more fully below, the hinge 52 is also foldable so as to allow the panels 36 to invert and the edges 56 to fold together to form a vertex. The ability of the hinge (or other foldable junction member) to allow adjacent panels to invert and fold against each other at adjacent edges is a substantial feature in creating a contracted state for the support member, and the prosthetic valve. In addition, the hinge 52 (or other foldable junction) preferably is adapted to allow the support member 32 to physically conform to the internal surface of the body lumen at the treatment location.

[0132] As noted below and elsewhere, various types of hinges and other foldable junctions may be used in alternative

embodiments. For example, and without intending to otherwise limit the descriptions contained herein, other types of hinges that may be used include standard piano hinges, living hinges, and other types of mechanical hinges. See, for example, the support member 32 shown in FIG. 1B, in which each pair of adjacent panels 36 is connected by a standard piano hinge 58, i.e., a long, narrow hinge with a pin 60 running the entire length of its joint that interconnects meshed sets of knuckles 62 formed on the edge of each of the pair of adjacent panels 36. Several other alternative hinge structures are shown in FIGS. 4A-D, in which FIGS. 4A-B show another membrane hinge in which the elastomeric strip 54 is attached to each of a pair of adjacent panels 36 on the internal surface of the support member 32. FIG. 4A shows a portion of the support structure 32 in its expanded state, and FIG. 4B shows the portion of the structure after the pair of adjacent panels 36 have been folded against each other at the membrane hinge 52, thereby forming a vertex 64. FIG. 4C shows a close-up view of another standard piano hinge 58 design, similar to that shown in FIG. 1B, showing the pin 60 and the meshing knuckles 62 formed on the edge of each of the pair of adjacent panels 36. FIG. 4D shows a living hinge 66 that includes a flexible (e.g., elastomeric) hinge member 68 that is attached to each of the pair of adjacent panels 36 and that extends the length of the junction between the panels. In addition, FIG. 5A shows another support member (in a partially contracted condition) illustrating removable hinge pins.

[0133] Several alternative foldable junctions may also be used instead of hinges. For example, a section of a sheet may be etched, scored, or otherwise thinned relative to the adjacent portions of the device to provide a weakened section that allows inversion and folding of a pair of adjacent segments of the sheet, thereby providing a foldable junction. Other alternative foldable junctions are also contemplated, and will be understood by persons of skill in the art, to be suitable for use in the support members described herein.

[0134] Optionally, the foldable junction may be provided with a lock-out feature that allows the foldable junction to fold in a direction that allows adjacent panels to invert, as described herein, but that prevents the foldable junction from folding in the opposite direction. For example, a standard piano hinge may be constructed in a manner that provides only about 180° of rotation in a conventional manner, and attached to a pair of adjacent panels such that inward rotation is allowed, but outward rotation is prevented. Other suitable lock-out mechanisms may be possible, as will be recognized by those of skill in the art.

[0135] In addition, although the hinges and other foldable junctions are preferably oriented uniformly vertically (i.e., parallel to the longitudinal axis of the support member) on the periphery of the support member, other orientations are possible. For example, the hinges may be oriented horizontally (i.e., transverse) relative to the longitudinal axis, they may be oriented diagonally relative to the longitudinal axis, they may have a zig-zag or spiral orientation, or they may take on any geometric or irregular pattern.

[0136] Returning again to FIG. 1A, the valvular body 34 of the embodiment shown in the figure is a flexible artificial tissue multi-leaflet structure. The artificial tissue includes a unitary polymer material or a composite of polymer overlaid onto a flexible substrate, which may be in the form of a mesh. The polymer material is any suitable flexible, biocompatible material such as those conventionally used in implantable medical devices. Preferably, the polymer material is polyure-

thane or another thermoplastic elastomer, although it is not limited to such materials. The material comprising the flexible mesh is preferably a flexible, shear-resistant polymeric or metallic material, such as a polyester or very fine metallic (e.g., stainless steel) mesh. The valvular body is described more fully below in relation to FIGS. 8A-B.

[0137] In other embodiments, the valvular body may be formed of human tissue, such as homografts or autografts, or animal tissue, such as porcine, bovine, or equine tissue (e.g., pericardial or other suitable tissue). The construction and preparation of prosthetic tissue valvular bodies is beyond the scope of the present application, but is generally known to those of skill in the art and is readily available in the relevant technical literature.

[0138] The prosthetic valves described herein have an expanded state that the prosthetic valve takes on when it is in use. The FIG. 1A illustration shows a prosthetic valve 30 in its expanded state. In the expanded state of the prosthetic valve, the support member is fully 32 extended in its cylindrical (or alternative) shape, with each hinge 52 (or other foldable junction) in its extended, or non-folded state. As described previously, in the expanded state, the support member 32 preferably has a cross-sectional dimension (e.g., diameter) that is from about 0 to about 25% larger than that of the body lumen or other treatment location. Once deployed, the support member extends to its full cross-sectional dimension—i.e., it does not compress radially due to the radial force imparted by the lumen or other tissue. Rather, the support member will expand the cross-sectional dimension of the lumen or other tissue at the treatment location. In this way, the support member reduces the possibility of fluid leakage around the periphery of the device. In addition, due to the strength of the interference fit that results from the construction of the device, the support member will have proper apposition to the lumen or tissue to reduce the likelihood of migration of the device once deployed. The present prosthetic valves also have a contracted state that is used in order to deliver the prosthetic valve to a treatment location with the body of a patient. The contracted state generally comprises a state having a smaller transverse dimension (e.g., diameter) relative to that of the expanded state. The contracted states of several of the prosthetic valve embodiments described herein are discussed below.

[0139] Turning to FIGS. 2A-C, a method for transforming a prosthetic valve from its expanded state to its contracted state is illustrated. These Figures show a three-panel support member without a valvular body attached. The method for contracting a full prosthetic valve, including the attached valvular body, is similar to that described herein in relation to the support member alone.

[0140] As shown in FIGS. 2A-B, each of the panels 36 is first inverted, by which is meant that a longitudinal centerline 80 of each of the panels is forced radially inward toward the central longitudinal axis 82 of the support member. This action is facilitated by having panels formed of a thin, resilient sheet of material having generally elastic properties, and by the presence of the hinges 58 located at the junction between each pair of adjacent panels 36. During the inversion step, the edges 56 of each of the adjacent pairs of panels fold upon one another at the hinge 58. The resulting structure, shown in FIGS. 2A-B, is a three-vertex 64 star shaped structure. Those skilled in the art will recognize that a similar procedure may be used to invert a four (or more) panel sup-

port member, in which case the resulting structure would be a four- (or more) vertex star shaped structure.

[0141] The prosthetic valve 30 may be further contracted by curling each of the vertices 64 of the star shaped structure to form a multi-lobe structure, as shown in FIG. 2C. As shown in that Figure, each of the three vertices 64 is rotated toward the center longitudinal axis of the device, causing each of the three folded-upon edges of the adjacent pairs of panels to curl into a lobe 84. The resulting structure, illustrated in FIG. 2C, is a three-lobe structure that represents the fully contracted state of the prosthetic valve. Manipulation and use of the fully contracted device is described more fully below. Those skilled in the art will recognize that a similar procedure may be used to fully contract a four (or more) panel support member, in which case the resulting structure would be a four- (or more) lobed structure.

[0142] In the case of a two panel support member, the support member may be contracted by first inverting one of the two panels to cause it to come into close relationship with the other of the two panels to form a nested panel structure. The pair of nested panels is then rolled into a small diameter tubular member, which constitutes the contracted state of the two-panel support member.

[0143] Turning to FIGS. 3A-I, another embodiment of a support member suitable for use in a 20 prosthetic valve is shown. This embodiment is structurally similar to the preceding embodiment, but is capable of being transformed to a contracted state in a different manner than that described above. The embodiment includes three panels 36, each having a semi-circular aperture 40. A standard piano hinge 58 is provided at two of the junctions between adjacent pairs of panels. (See FIG. 3B). The third junction does not have a hinge, instead having a locking member 90. In the embodiment shown, the locking member includes a tab 92 attached to each of the top and bottom portions of the edge of the first 36a of a pair of adjacent panels, and a slot 94 provided along both the top and bottom edges of the second 36b of the pair adjacent panels. (See FIG. 3C). The tabs 92 on the first panel 36a are able to extend through and ride in the slots 94 on the second panel 36b, thereby allowing the first panel 36a to slide relative to the second panel 36b while remaining physically engaged to the panel, and then to slide back to the original position. A locking tab 96 may be provided on the second panel 36b to selectively lock the first panel tab 92 in place in the slot 94.

[0144] FIGS. 3D-G illustrate the manner in which the preceding support member is transformed to its contracted state. As shown in FIG. 3D, the panel 36c situated opposite the locking junction 90 is inverted while leaving the other two panels 36a-b in their uninverted state. The tabs 92 on the first panels 36a are then slid along the slots 94 in the second panel 36b, causing the first and second panels 36a-b to come into a nested arrangement behind the inverted panel 36c, with the first panel 36a nested between the inverted panel 36c and the second panel 36b. (See FIG. 3E). The nested panels are then able to be curled into a relatively small diameter tubular member 98, as shown in FIGS. 3F and 3G, which constitutes the contracted state of the support member.

[0145] FIGS. 3H-I illustrate a similar support member in its partially contracted state in which the three panels 36a-c are in the nested arrangement. The support member shown in FIGS. 3H-I also include a plurality of brace members 42 extending through the aperture 40, forming diamond-shaped sub-apertures 46, partial diamond-shaped sub-apertures 48,

and an elongated sub-aperture 50. A plurality of raised surfaces 100, or bumps, are provided over the surfaces each of the panels 36a-c to provide positive spacing for the valvular body 34 when the prosthetic valve 30 is placed in the contracted state. The positive spacing provided by the raised surfaces 100 serve to decrease the possibility of squeezing, crimping, folding, or otherwise damaging the valvular body 34 or its constituent parts when the prosthetic valve is contracted. The raised 5 surfaces 100 (or other spacing member) of the support member may be used on any of the embodiments of the prosthetic valves described herein.

[0146] Turning to FIGS. 5A-B, as described above, FIG. 5A illustrates a support member 32 having three panels 36a-c and three standard piano hinges 58 at the junctions between the three panels. The support member is shown with each of its three panels 36a-c in the inverted position. Each of the piano hinges 58 has a removable hinge pin 60. When the hinge pins 60 are removed, the panels 36a-c may be separated from each other, as illustrated in FIG. 5B. The ability to separate the panels may be used to facilitate surgical (or other) removal of the support member, or the prosthetic valve, or the panels may need to be separated for another purpose. Although piano hinges with removable hinge pins are shown in FIGS. 5A-B, alternative removable hinge structures may also be used. For example, a membrane hinge having a tearable membrane strip will facilitate removal of the support member. Further alternatives may include melting or unzipping a hinge. Other removable hinge structures are also contemplated. In each of these cases, provision of a hinge that may be easily defeated by some mechanism creates that ability for the user to more easily remove or otherwise manipulate a prosthetic valve or support member for any desired purpose.

[0147] FIG. 6 shows another embodiment of a support member 32 suitable for use in a prosthetic valve 30. The support member 32 includes three panels 36a-c, each panel having an elongated aperture 50 and a semi-circular aperture 40. The support member includes an elastomeric strip 54 at the foldable junction between each pair of adjacent panels, each of which forms a membrane hinge. A valvular body attachment lip 104 is attached to the interior surface of each of the panels 36a-c to facilitate attachment of the valvular body 34 to the support member 32. The attachment lip 104 may comprise a polymer material suitable for sewing, adhering, or otherwise attaching to the valvular body. The attachment lip 104 is preferably molded or adhered onto the interior surface of each of the panels of the support member. Although the attachment lip 104 facilitates one method for attaching the valvular body to the support member, it is not the only method for doing so, and use of the attachment lip 104 is optional.

[0148] FIG. 7 illustrates another structure and method used to attach the valvular body to the support member panels. A first strip 110 of polymeric material is adhered to the interior surface of the edge 56 of each panel. The first strip 110 of polymeric material does not need to extend along the entire edge, but generally about half of the length. The first strip 110 is adhered with any suitable adhesive material, or it may be molded directly onto the panel 36. An attachment lip 120 formed on the base portion of the valvular body is then attached to each of the first strips 110 of polymeric material. The attachment lips 120 may be formed on the base portion of the valvular body 34 in any of the embodiments described below, including those having a unitary structure or those having a composite structure. (A composite structure is shown in FIG. 7). The attachment lips 110 may be attached to

the strips of polymeric material using any suitable adhesive or any other suitable method. Next, and optionally, a second strip 112 of polymer material may be attached to the exposed surface of the valvular body attachment lip 120, sandwiching the attachment lip 120 between the first 110 and second strips 112 of material.

[0149] FIGS. 8A-B show perspective views of valvular bodies suitable for use in the valves described herein. The valvular body 34 shown in FIG. 8A is of a unitary construction, while that shown in FIG. 8B is of a composite construction, including three separate leaflets 35a-c. Turning first to the unitary structure embodiment shown in FIG. 8A, the valvular body 34 includes a generally cylindrical base portion 122 that then contracts down into a generally concave portion 124 (as viewed from the 'interior of the valvular body). The valvular body 34 has three lines of coaptation 126 formed on the bottom of the concave portion 124. A slit 128 is either cut or molded into each of the lines of coaptation 126 to create three valve leaflets 130 that perform the valvular fluid regulation function when the valve is implanted in a patient. An optional attachment lip 120 may be formed on the outward facing lines of coaptation 126, to facilitate attachment of the valvular body 34 to the support member in the manner described above in relation to FIG. 7.

[0150] Turning to the composite structure embodiment shown in FIG. 8B, each separate leaflet 35a-c includes a base portion 132 and a generally concave portion 134 extending from the base. Each leaflet 35a-c also includes a pair of top edges 136 and a pair of side edges 138. The top edges and side edges of each leaflet 35a-c are positioned against the top edges and side edges of each adjacent leaflet when the composite structure embodiment is attached to an appropriate support member.

[0151] As described above, in either the unitary or composite construction embodiments, the valvular body may be formed solely from a single polymer material or polymer blend, or it may be formed from a substrate having a polymer coating. The materials suitable for use as the polymer, substrate, or coating are described above. Alternatively, the valvular body may comprise human or animal tissue.

[0152] The valvular body may be attached to the support member by any suitable method. For, the valvular body may be attached to the support member by sewing, adhering, or molding the valvular body to an attachment lip, as described above in relation to FIG. 6. Or, the valvular body may be attached to the support member using the attachment strips described above in relation to FIG. 7. Alternatively, the valvular body may be adhered directly to the support member using an adhesive or similar material, or it may be formed integrally with the support member. Other and further suitable attachment methods will be recognized by those skilled in the art.

[0153] The multi-segment support member embodiments described above are suitable for use in the prosthetic valves described herein. Additional structures are also possible, and several are described below. For example, in reference to FIGS. 9A-B, an alternative support member is illustrated. The alternative support member is a tubular member that is capable of radial expansion caused by forced foreshortening. As noted earlier herein, several structures and/or methods are available that are capable of this form of transformation, one of which is described in FIGS. 9A-B. An axially activated support member 150 includes a generally tubular body member 152 formed of a matrix of flexible struts 154. In the

embodiment shown in the Figures, the struts **154** are arranged in crossing pairs forming an “X” pattern, with the ends of a first crossing pair of struts being connected to the ends of a second crossing pair of struts by a band connector **156**, thereby forming a generally cylindrical member. Additional generally cylindrical members are incorporated into the structure by interweaving the struts contained in the additional cylindrical member with the struts included in the first cylindrical member. An axial member **158** is connected to two opposed band connectors **156** located on opposite ends of the structure. When the axial member **158** is decreased in length, as shown in FIG. 9B, the support member **150** is expanded to a large diameter state, accompanied by a degree of lengthwise foreshortening of the support member. When the axial member **158** is increased in length, as shown in FIG. 9A, the support member **150** is contracted to a smaller diameter state, accompanied by a degree of lengthening of the support member. The expanded state may be used when the support member is deployed in a body lumen, and the contracted state may be used for delivery of the device. A valvular body, as described above, may be attached to the internal or external surface of the support member.

[0154] Another support member is shown in FIGS. 10A-J. In this alternative embodiment, the support member comprises a multiple panel hinged ring structure **170**. The multiple panel hinged ring structure includes three circumferential rings **172** interconnected by three longitudinal posts **174**. More or fewer rings and/or posts may be used. Each ring structure, in turn, is composed of a plurality of curved panels **176**, each connected to its adjacent panel by a junction member **178**, such as a polymeric membrane hinge. The individual panels **176** have a curvature **180** about the axis of the device as well as a curvature **182** in the transverse direction. (See FIG. 10E). A coating material **184** maintains the panels in relation to one another, as well as providing a foldable junction **186**. The curvature of the panels in conjunction with the coating **184** maintains the ring structure in the expanded condition, as shown in FIGS. 10A, 10C, and 10D. The foldable junctions **186** are rotated to transform the structure from an expanded state **188** for deployment, to a contracted state **190** for delivery. (See FIG. 10E-J). A valvular body, as described elsewhere herein, may be attached to the internal or external surface of the, support member.

[0155] In still another alternative embodiment, as shown in FIGS. 11A-C, the support member comprises a collapsing hinged structure **200**. The collapsing hinged structure shown in the Figures includes twenty-four panels **202** arranged peripherally around the generally tubular structure, each panel having a tab **204** on its edge that overlaps and engages a mating tab **206** on the opposed edge of the adjacent panel, interlocking the adjacent panels. More or fewer panels are possible. An elastic membrane **208** is attached to an external surface of adjacent panels and provides a force biasing the adjacent panels together to assist the tabs in interlocking each adjacent pair of panels. Preferably, the elastic membrane **208** is attached to the main body of each panel **202**, but not at the opposed edges. Thus, the tabs **204**, **206** may be disengaged and the panels **202** rotated to form a vertex **210** at each shared edge, thereby defining a multi-vertex “star” shape that corresponds with the contracted state of the support member. The support member **200** is transformed to its expanded state by applying an outward radial force that stretches the elastic membrane **208** and allows the tabs **204**, **206** to re-engage. A

valvular body, as described elsewhere herein, is attached to the internal or external surface of the support member.

[0156] All of the foregoing support members may be incorporated in a prosthetic valve, as described above, by attaching a valvular body to the external or internal surface of the support member. In the alternative, all of the foregoing support members may be utilized without a valvular body to provide a support or scaffolding function within a body lumen, such as a blood vessel or other organ. For example, the multi-segment, multi-hinged support member may be used as a scaffolding member for the treatment of abdominal aortic aneurysms, either alone, or in combination with another support member, graft, or other therapeutic device. Other similar uses are also contemplated, as will be understood by those skilled in the art.

[0157] Moreover, several additional features and functions may be incorporated on or in the prosthetic valve or its components, including the support member and the valvular body. For example, one or more anchoring members may be formed on or attached to any of the above-described support member embodiments. Each anchoring member may comprise a barb, a tooth, a hook, or any other member that protrudes from the external surface of the support structure to physically engage the internal wall of the body lumen. An anchoring member may be selectively engageable, such as by an actuator, or it may be oriented so as to be permanently in its engaged state. Alternatively, the anchoring member may comprise an aperture formed in the support structure that allows tissue to invaginate therethrough. One example of an anchoring member is illustrated in FIGS. 13B and 13C, where a barb **358** is shown extending from the surface of a contracted prosthetic valve **30**. The barb **358** may be deflected inward while the prosthetic valve is retained in the delivery device. See FIG. 13C. Then, upon deployment, the barb **358** is released and extends radially outward to engage the surface of the body lumen or other tissue. As noted above, other anchoring members and mechanisms are also contemplated for use with the devices described herein.

[0158] The prosthetic heart valves and support members described herein provide a number of advantages over prior devices in the art. For example, the prosthetic heart valves are able to be transformed to a contracted state and back to an expanded state without causing folding, tearing, crimping, or otherwise deforming the valve leaflets. In addition, unlike prior devices, the expanded state of the current device has a fixed cross-sectional size (e.g., diameter) that is not subject to recoil after expansion. This allows the structure to fit better at its treatment location and to better prevent migration. It also allows the valvular body to perform optimally because the size, shape and orientation of the valve leaflets may be designed to a known deployment size, rather than a range. Still further, because the expanded state of the support structure is of a known shape (again, unlike the prior devices), the valve leaflets may be designed in a manner to provide optimal performance.

B. Delivery Devices and Methods of Use

[0159] Devices for delivering a prosthetic valve to a treatment location in a body lumen are described below, as are methods for their use. The delivery devices are particularly adapted for use in minimally invasive interventional procedures, such as percutaneous aortic valve replacements. FIGS. 14A and 15A illustrate two embodiments of the devices. The delivery devices **300** include an elongated delivery catheter

302 having proximal **304** and distal ends **306**. A handle **308** is provided at the proximal end of the delivery catheter. The handle **308** may be provided with a knob **310**, an actuator, a slider, other control members, or combinations thereof for controlling and manipulating the catheter to perform the prosthetic valve delivery procedure. A retractable outer sheath **312** may extend over at least a portion of the length of the catheter. Preferably, a guidewire lumen extends proximally from the distal end of the catheter. The guidewire lumen may extend through the entire length of the catheter for over-the-wire applications, or the guidewire lumen may have a proximal exit port closer to the distal end of the catheter than the proximal end for use with rapid-exchange applications. The distal portion **306** of the catheter includes a carrier adapted to receive and retain a prosthetic valve in a contracted state, and to deploy the prosthetic valve at a treatment location within a body lumen.

[0160] Turning first to FIGS. 12A-F, a first embodiment of a distal portion **306** of a prosthetic valve delivery device is shown. The device **300** includes a delivery tube **320** having three longitudinal slots **322** at its distal end, and a gripper **324** having a longitudinal shaft **326** and three fingers **328** that extend longitudinally from the distal end of the gripper. More or fewer longitudinal slots may be included on the delivery tube, and more or fewer fingers may be provided on the gripper. Preferably, the delivery tube **320** has the same number of longitudinal slots, and the gripper **324** includes the same number of fingers, as there are segments on the prosthetic valve to be delivered. The longitudinal slots **322** on the distal end of the delivery tube are equally spaced around the periphery of the tube. Similarly, as viewed from the distal end of the gripper **324**, the fingers **328** are arranged in an equi-spaced circular pattern. For example, in the case of three fingers, all three are equally spaced apart on an imaginary circle and are separated from each other by 120°. In the case of four fingers, the fingers would be separated from each other by 90°, and so on.

[0161] The gripper **324** is slidably and rotatably received within the delivery tube **320**, and the delivery tube is internal of the outer sheath (not shown in FIGS. 12A-F). The outer sheath is retractable to expose at least the longitudinal slots **322** on the distal portion of the delivery tube. The gripper **324** is able to be advanced at least far enough to extend the fingers **328** distally outside the distal end of the delivery tube.

[0162] In alternative embodiments of the above delivery device, the gripper fingers **328** may comprise wires, fibers, hooks, or other structural members extending distally from the distal end of the gripper. As described below, a primary function of the fingers is to retain a prosthetic valve on the distal end of the gripper, and to restrain segments of the support member of the valve in an inverted state. Accordingly, any of the above (or other) structural members able to perform the above function may be substituted for the fingers described above.

[0163] The delivery device **300** is particularly adapted for use in a minimally invasive surgical procedure to deliver a multi-segment prosthetic valve **30**, such as those described above, to a body lumen. To do so, the prosthetic valve **30** is first loaded into the delivery device **300**. FIGS. 12A-F illustrate the case of a prosthetic valve having a three segment support member. The prosthetic valve **30** is loaded into the delivery device **300** by first inverting the three panels **36** to produce a three vertex structure. Inverting of the prosthetic valve panels may be performed manually, or by using an

inverting tool. The prosthetic valve **30** is then placed onto the distal end of the gripper **324**, which has been previously extended outside the distal end of the delivery tube **320**, with each of the three fingers **328** retaining one of the inverted panels **36** in its inverted position. (See FIG. 12A). The gripper **324** and fingers **328**, with the prosthetic valve **30** installed thereon, are then retracted back into the delivery tube **320**. During the retraction the gripper **324** and fingers **328** are rotationally aligned with the delivery tube **320** such that the three vertices of the prosthetic valve align with the three longitudinal slots on the distal end of the delivery tube. (See FIG. 12B). When the gripper **324** and fingers **328** are fully retracted, each of the three vertices of the prosthetic valve extends radially outside the delivery tube through the longitudinal slots **322**. (See FIG. 12C). The gripper **324** is then rotated relative to the delivery tube **320**, which action causes each of the folded segments of the prosthetic valve **30** to engage an edge of its respective delivery tube slot. (See FIG. 12D). Further rotation of the gripper **324** relative to the delivery tube **320** causes the folded segments to curl back toward the longitudinal axis of the prosthetic valve internally of the delivery tube, creating three lobes located fully within the delivery tube **320**. (See FIG. 12E). The prosthetic valve **30** is thereby loaded into the delivery device **300**. The outer sheath is then advanced over the distal portion of the catheter, including the delivery tube, to prepare the delivery device for use.

[0164] The prosthetic valve **30** is delivered by first introducing a guidewire into the vascular system and to the treatment location of the patient by any conventional method, preferably by way of the femoral artery. Optionally, a suitable introducer sheath may be advanced to facilitate introduction of the delivery device. The delivery catheter **302** is then advanced over the guidewire to the treatment location. The outer sheath **312** is then retracted to expose the delivery tube **320**. The gripper **324** is then rotated relative to the delivery tube **320** (or the delivery tube rotated relative to the gripper), thereby causing the folded panels of the prosthetic valve **30** to uncurl and to extend radially outward through the longitudinal slots **322** of the delivery tube **320**. The delivery tube **320** is then retracted (or the gripper advanced) to cause the prosthetic valve **30** (restrained by the fingers **328**) to advance distally out of the delivery tube. The gripper **324** is then retracted relative to the prosthetic valve **30**, releasing the prosthetic valve **30** into the treatment location. (See FIG. 12F). Preferably, the inverted panels **36** then revert to the expanded state, causing the valve to lodge against the internal surface of the body lumen (e.g., the aortic valve root or another biologically acceptable aortic position). Additional expansion of **10** the prosthetic valve may be provided, if needed, by a suitable expansion member, such as the expansion balloon or the expanding mesh member described elsewhere herein, carried on the delivery catheter **302** or other carrier.

[0165] Turning to FIGS. 13A-E, another embodiment of a distal portion of a prosthetic valve delivery device is shown. The distal portion of the catheter **302** includes a restraining sheath **340**, an orientation sheath **342**, a plurality of grippers **344**, an expander **346**, and a plurality of struts **348**. Each of the grippers **344** includes a wire **350** riding within a tube **352**, and a tip **354** at the distal end of the tube. The wire **350** of each gripper **344** has an end portion **356** formed to engage the vertex of a prosthetic valve support member **32** having multiple segments, and to selectively restrain the prosthetic valve **30** in a contracted state. (See FIG. 13B). The expander **346** is

adapted to selectively cause the grippers **344** to expand radially outwardly when it is actuated by the user by way of an actuator **310** located on the handle **308**.

[0166] The prosthetic valve **30** may be loaded into the delivery device **300** by contracting the prosthetic valve (either manually or with an inverting tool) by inverting each panel **36** and then attaching each vertex to a respective end portion **356** of the wire contained on each gripper **344** on the delivery device. The gripper wires **350** receive, retain, and restrain the prosthetic valve **30** in its contracted state. The gripper **344** assembly having the prosthetic valve **30** installed is then retracted into each of the orientation sheath **342** and the restraining sheath **340** to prepare the device for insertion into the patient's vasculature. The device is then advanced over a guidewire to a treatment location, such as the base annulus of the native aortic valve. (See FIG. 13E). The restraining sheath **340** is then retracted to allow the prosthetic valve **30** to partially expand (e.g., to about 85% of its full transverse dimension), where it is constrained by the orientation sheath **342**. The prosthetic valve **30** is then finally positioned by manipulation of the grippers **344**, after which the orientation sheath **342** is retracted and the grippers **344** released. The prosthetic valve **30** then lodges itself in the treatment location.

[0167] Other embodiments of the delivery device are illustrated in FIGS. 14A-E and 15A-B. As shown in those Figures, the distal portion **306** of the catheter includes one or more restraining tubes **370** having at least one (and preferably two) adjustable restraining loops **372**. In the embodiment shown in FIGS. 14A-E, the device is provided with one restraining tube **370** and two restraining loops **372**. In the embodiment shown in FIGS. 15A-B, the device is provided with three restraining tubes **370** and two restraining loops **372**. The restraining tube(s) **370** extend distally from a catheter shaft **374** out of the distal end of the delivery device, and each restraining loop **372** is a wire or fiber loop that extends transversely of the restraining tube **370**. Each restraining loop **372** is a flexible loop capable of selectively restraining a contracted prosthetic valve. The restraining loops **372** may be selectively constricted or released by a control member, such as a knob **310**, located on the handle **308** of the device. A retractable outer sheath **376** covers the distal portion of the catheter.

[0168] The prosthetic valve **30** may be loaded onto the delivery device by contracting the prosthetic valve (either manually or with an inverting tool) into its contracted state, for example, by inverting each panel **36** and curling each inverted panel into a lobe. The contracted prosthetic valve is then placed onto the restraining tube(s) **370** and through the one or more restraining loops **372**. (See, e.g., FIG. 14B). The loops **372** are constricted around the contracted prosthetic valve **30**, thereby restraining the prosthetic valve in its contracted state. The outer sheath **376** is then advanced over the prosthetic valve and the restraining tube(s) to prepare the delivery device for use. (See FIG. 14C). The device is then advanced over a guidewire to a treatment location, such as the base annulus of the native aortic valve. (See FIG. 14D). The restraining sheath **376** is then retracted to expose the contracted prosthetic valve **30**. The restraining loops **372** are released, such as by rotating the control knob **310**, thereby releasing the prosthetic valve **30** and allowing it to self-expand. (See FIG. 14E). The prosthetic valve **30** then lodges itself in the treatment location. An expansion member may be advanced to the interior of the prosthetic valve and expanded to provide additional expansion force, if needed or desired.

[0169] Another embodiment of the delivery device is shown in FIGS. 16A-B. As shown there, the distal portion of the catheter includes a gripper **400** that includes a base portion **402** having three restraining members **404** extending distally from the gripper base. In the embodiment shown, each of the restraining members **404** includes a wire loop **406** extending through a sleeve **408**, with both the sleeve and the wire loop extending distally from the gripper base **402**. The wire loops **406** also extend proximally of the gripper base **402**, which is provided with a lumen **410** corresponding with each of the wire loops **406**, thereby allowing the gripper base **402** and the sleeves **404** to slide relative to the wire loops **406**. A delivery tube **412** may also be provided. As shown in the Figures, the gripper **400** is slidably received within the delivery tube **412**, and the tube has three longitudinal slots **414** corresponding with the three restraining members **404** on the gripper assembly. An atraumatic tip **416** or nosecone is attached to a central shaft **418** that extends through the center of the catheter **302** internally of the gripper **400** and the delivery tube **412**. The central shaft **418** includes a guidewire lumen to accommodate a guidewire used to assist deployment of the delivery device.

[0170] Although the device shown in the Figures includes three restraining members **404**, fewer or additional restraining members may be used. One function of the restraining members is to retain a prosthetic valve on the distal end of the delivery device, and to selectively maintain the valve in a contracted state. In the preferred embodiment, the number of restraining members will coincide with the number of segments (e.g., panels) included on the prosthetic valve.

[0171] Turning to FIG. 16A, the delivery device **300** is shown with the delivery tube **412** and gripper **400** retracted relative to the wire loops **406**, thereby allowing the distal end **420** of the wire loops to extend freely away from the central shaft **418**. The delivery device in this condition is adapted to have a prosthetic valve installed onto the device. To do so, the prosthetic valve **30** is first placed over the distal end of the device and the panels **36** of the valve are inverted. Alternatively, the valve panels **36** may be inverted prior to or simultaneous with placing the valve over the distal end of the delivery device. The wire loops **406** are then placed over the inverted panels **36**, and the gripper **400** is advanced to cause the sleeves **408** to physically engage the inverted panels **36**. See FIG. 16B. The sleeves **408** have sufficient strength to maintain the prosthetic valve panels in their inverted state. The delivery tube **412** may then be advanced over the distal end of the device, with the valve panel vertices extending out of the longitudinal slots **414** formed on the delivery tube **412**. The gripper **400** may then be rotated relative to the delivery tube (or vice versa) to contract the panel vertices within the interior of the delivery tube and to thereby prepare the device for delivery of the prosthetic valve. The valve is delivered in the same manner described above in relation to the device shown in FIGS. 12A-E.

[0172] As noted, each of the foregoing delivery devices is suitable for use in delivering a prosthetic heart valve or a support member, such as those described herein. In the case of a prosthetic heart valve, the delivery methods may be combined with other treatment devices, methods, and procedures, particularly procedures intended to open or treat a stenotic heart valve. For example, a valvuloplasty procedure may be performed prior to the prosthetic heart valve deployment. The valvuloplasty procedure may be performed using a conventional balloon or a cutting balloon adapted to cut scarred

leaflets so that they open more easily. Other treatments, such as chemical treatments to soften calcifications or other disorders may also be performed.

[0173] Each of the foregoing delivery devices may be provided with a tether connecting the delivery device to the prosthetic valve or support member. The tether is preferably formed of a material and has a size sufficient to control the prosthetic valve or support member in the event that it is needed to withdraw the device during or after deployment. Preferably, the tether may be selectively disengaged by the user after deployment of the device.

[0174] Turning to FIGS. 17A-B and 18A-D, two types of expansion members are provided for performing dilation functions in minimally invasive surgical procedures. The expansion members may be used, for example, in procedures such as angioplasty, valvuloplasty, stent or other device placement or expansion, and other similar procedures. In relation to the devices and methods described above and elsewhere herein, the expansion members may be used to provide additional expansion force to the support members used on the prosthetic valves described herein.

[0175] In one embodiment, illustrated in FIGS. 17A-B, the expansion member 430 includes three elongated inflation balloons 432a-c oriented about a longitudinal axis 434. Each inflation balloon 432 is connected at its proximal end by a feeder lumen 436 to a central lumen 438 that provides fluid communication between the inflation balloons 432a-c and a source of inflation media associated with a handle portion 308 of a catheter. The central lumen itself is provided with a guidewire lumen 440 to allow passage of a guidewire through the expansion member 430. A flexible member 442 is attached to the distal end of each of the inflation balloons 432a-c, and also includes a guidewire lumen. Although the expansion member shown in the Figures includes three inflation balloons, fewer or more balloons are possible. Moreover, each of the individual balloons may be inflated separately, all inflated together, or any combination thereof to obtain a desired force profile. The multiple inflation balloon structure provides a number of advantages, including the ability to provide greater radial forces than a single balloon, and the ability to avoid occluding a vessel undergoing treatment and to allow blood or other fluid to flow through the device.

[0176] In an alternative embodiment, shown in FIGS. 18A-D, the expansion member 450 comprises a flexible, expandable mesh member 452. The expandable mesh member 452 includes a shaft 454 and a cylindrical woven mesh member 452 disposed longitudinally over the shaft. A distal end 456 of the cylindrical mesh member is attached to the distal end 458 of the shaft. The proximal end 460 of the cylindrical mesh member is slidably engaged to the shaft by a collar 462 proximally of the distal end 456. As the collar 462 is advanced distally along the shaft 454, the body of the cylindrical mesh member 452 is caused to expand radially, thereby providing a radially expandable member.

[0177] The preferred embodiments of the inventions that are the subject of this application are described above in detail for the purpose of setting forth a complete disclosure and for the sake of explanation and clarity. Those skilled in the art will envision other modifications within the scope and spirit of the present disclosure. Such alternatives, additions, modifications, and improvements may be made without departing from the scope of the present inventions, which is defined by the claims.

What is claimed is:

- 1. A prosthetic heart valve comprising:
 - a support member having a plurality of segments and at least one foldable junction member connecting two adjacent segments, the support member having an expanded state and a contracted state, and
 - a valvular body having a plurality of leaflets attached to said support member.
- 2. The prosthetic heart valve of claim 1, wherein said support member comprises at least three segments.
- 3. The prosthetic heart valve of claim 1, wherein each segment comprises a panel.
- 4. The prosthetic heart valve of claim 1, wherein said support member is generally tubular in the expanded state.
- 5. The prosthetic heart valve of claim 4, wherein said support member is generally cylindrical in the expanded state.
- 6. The prosthetic heart valve of claim 4, wherein said support member has a generally oval cross-sectional shape when the support member is in the expanded state.
- 7. The prosthetic heart valve of claim 1, wherein said foldable junction member comprises a hinge.
- 8. The prosthetic heart valve of claim 7, wherein said hinge comprises one of the following: a mechanical hinge, a membrane hinge, or a living hinge.
- 9. The prosthetic heart valve of claim 8, wherein said hinge comprises a mechanical hinge having a removable pin.
- 10. The prosthetic heart valve of claim 1, wherein said support member further comprises an anchoring member.
- 11. The prosthetic heart valve of claim 10, wherein said anchoring member has a delivery position and a deployment position, and further comprising an actuator adapted to move said anchoring member from its delivery position to its deployment condition.
- 12. The prosthetic heart valve of claim 10, wherein said anchoring member has a delivery position and a deployment position, and wherein said anchoring member is self-actuating from its delivery position to its deployment position.
- 13. The prosthetic heart valve of claim 1, wherein at least one of said plurality of segments is inverted when the support member is in its contracted state.
- 14. The prosthetic heart valve of claim 13, wherein all of said plurality of segments are formed into a generally tubular shape when the support member is in its contracted state.
- 15. The prosthetic heart valve of claim 13, wherein each of said plurality of segments is inverted when the support member is in its contracted state, whereby each foldable junction 5 member forms an elongated vertex.
- 16. The prosthetic heart valve of claim 15, wherein each pair of adjacent segments forms a lobe when the support member is in its contracted state.
- 17. The prosthetic heart valve of claim 1, wherein said plurality of leaflets of said valvular body are separate.
- 18. The prosthetic heart valve of claim 1, wherein said valvular body comprises animal tissue.
- 19. The prosthetic heart valve of claim 1, wherein said valvular body comprises human tissue.
- 20. The prosthetic heart valve of claim 1, wherein said plurality of leaflets of said valvular body comprise a coated substrate.

* * * * *