

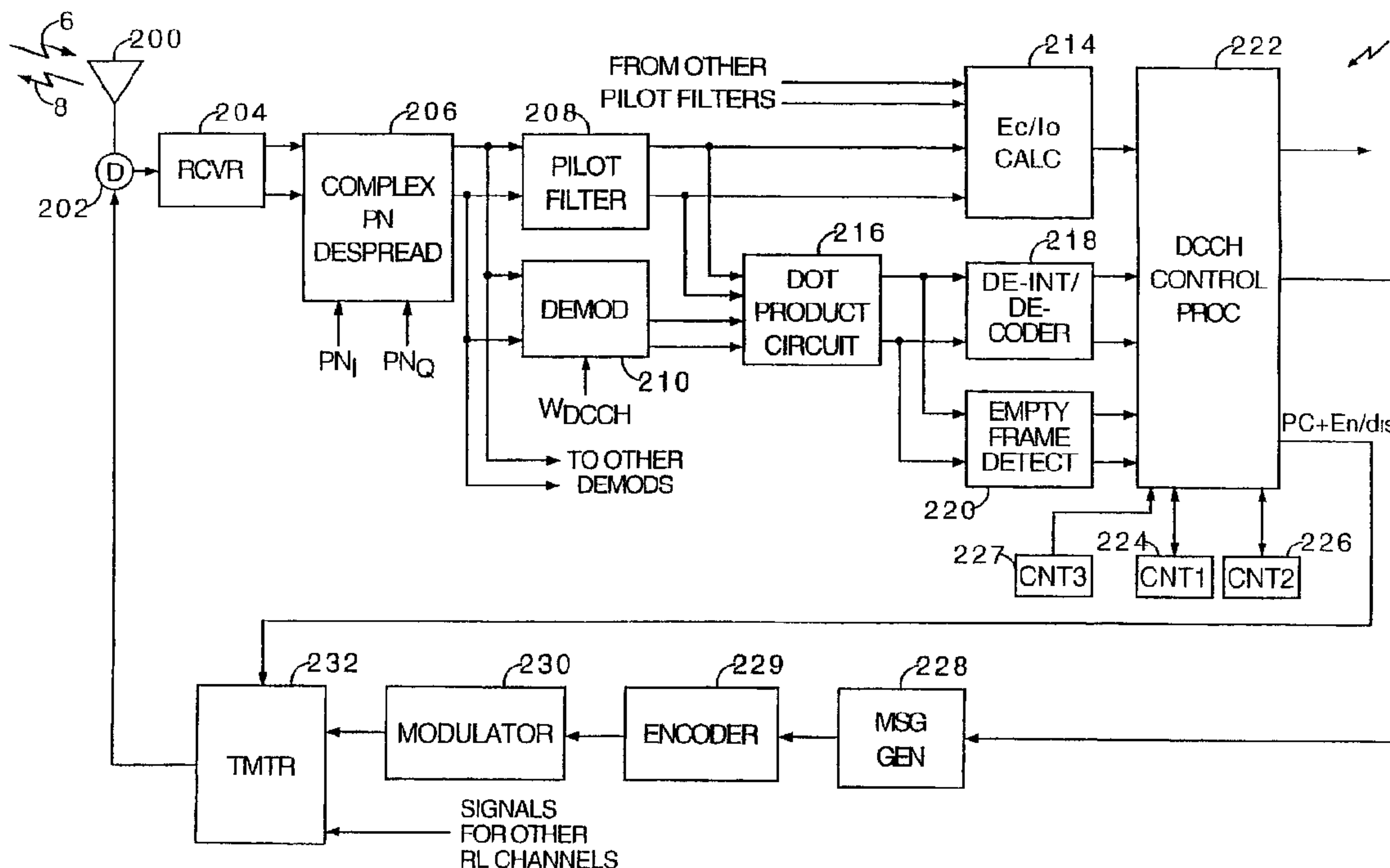

(22) Date de dépôt/Filing Date: 2000/07/20
 (41) Mise à la disp. pub./Open to Public Insp.: 2001/02/01
 (45) Date de délivrance/Issue Date: 2008/07/15
 (62) Demande originale/Original Application: 2 378 884
 (30) Priorité/Priority: 1999/07/21 (US09/358,634)

(51) Cl.Int./Int.Cl. *H04Q 7/38* (2006.01),
H04Q 7/34 (2006.01)
 (72) Inventeurs/Inventors:
JOU, YU-CHEUN, US;
TIEDEMANN, EDWARD G., JR., US
 (73) Propriétaire/Owner:
QUALCOMM INCORPORATED, US
 (74) Agent: SMART & BIGGAR

(54) Titre : SURVEILLANCE DE STATION MOBILE DE CANAL DE COMMANDE AFFECTE A L'ACHEMINEMENT EN MODE DE TRANSMISSION DISCONTINUE
 (54) Title: MOBILE STATION SUPERVISION OF THE FORWARD DEDICATED CONTROL CHANNEL WHEN IN THE DISCONTINUOUS TRANSMISSION MODE



(57) **Abrégé/Abstract:**

A method and apparatus for supervising a dedicated control channel when in the discontinuous transmission mode. The mobile station (4) monitors the frames it receives from a base station (2) and maintains a counter of bad, good, and empty frames, referred to as COUNT 1, COUNT2, COUNT3, respectively. If a received frame is a good frame, COUNT1 is reset to zero and COUNT2 is incremented. If the received frame is a bad frame, COUNT1 is incremented and COUNT2 is reset to zero. If the received frame is an empty frame, COUNT1 and COUNT2 are unchanged but COUNT3 is incremented. A transmitter coupled to the mobile station is enabled or disabled depending upon which, if any, of the COUNTs reaches or exceeds a designated threshold value.

Abstract

A method and apparatus for supervising a dedicated control channel when in the discontinuous transmission mode. The mobile station (4) monitors the frames it receives from a base station (2) and maintains a counter of bad, good, and empty frames, referred to as COUNT1, COUNT2, COUNT3, respectively. If a received frame is a good frame, COUNT1 is reset to zero and COUNT2 is incremented. If the received frame is a bad frame, COUNT1 is incremented and COUNT2 is reset to zero. If the received frame is an empty frame, COUNT1 and COUNT2 are unchanged but COUNT3 is incremented. A transmitter coupled to the mobile station is enabled or disabled depending upon which, if any, of the COUNTs reaches or exceeds a designated threshold value.

MOBILE STATION SUPERVISION OF THE FORWARD
DEDICATED CONTROL CHANNEL WHEN IN THE
DISCONTINUOUS TRANSMISSION MODE

5

BACKGROUND OF THE INVENTION

I. Field of the Invention

The present invention relates to communications. More particularly,
10 the present invention relates to a method and apparatus for supervising a
control channel used in a telecommunications system.

II. Description of the Related Art

15 The telecommunications Industry Association developed a standard
for code division multiple access (CDMA) communications systems in the
Interim Standard IS-95A, entitled "Mobile Station-Base Station
Compatibility Standard for Dual-Mode Wideband Spread Spectrum Cellular
System" (hereafter IS-95). In IS-95 systems, the mobile station controls the
20 energy of its transmissions by means of a combination of open loop and
closed loop power control methods. In open loop power control, a mobile
station measures the received energy of the forward link signal from a
serving base station and adjusts the energy of its reverse link transmission
in accordance with this measurement. In closed loop power control, the
25 serving base station measures the energy of transmissions from the mobile
station and sends a series of up/down commands based on this
measurement to the mobile station which adjusts its transmissions in
response. A power control system employing closed loop and open loop
power control is described in U.S. Patent No. 5,056,109, entitled "METHOD
30 AND APPARATUS FOR CONTROLLING TRANSMISSION POWER IN A
CDMA CELLULAR MOBILE TELEPHONE SYSTEM".

In IS-95, the mobile station is required to monitor the Forward Traffic Channel performance during a call. When the mobile station receives twelve (N_{2m}) consecutive bad frames, the mobile station is required to disable its transmitter so that it will not jam the reverse link. Thereafter, if
5 the mobile station receives two (N_{3m}) consecutive good frames, it should re-enable its transmitter. The mobile station also maintains a fade timer. The fade timer is first enabled when the mobile station enables its transmitter at the beginning of a call, and it is reset for five (T_{5m}) seconds whenever two (N_{3m}) consecutive good frames are received on the Forward Traffic Channel.
10 If the fade timer expires, the mobile station disables its transmitter and declares a loss of the Forward Traffic Channel and terminates the call.

The International Telecommunications Union recently requested the submission of proposed methods for providing high rate data and high-quality speech services over wireless communication channels. A first of
15 these proposals was issued by the Telecommunications Industry Association, entitled "The cdma2000 ITU-R RTT Candidate Submission" (hereafter cdma2000). In cdma2000, the equivalents of the Forward Traffic Channel in IS-95 are the Forward Fundamental Channel (F-FCH) and the Forward Dedicated Control Channel (F-DCCH). The data frames
20 transmitted on these channels can be either 20 ms or 5 ms in duration. For F-FCH, a frame (20 or 5 ms) is transmitted in every 20 ms interval aligned to the beginning of the CDMA System Time. For F-DCCH, the transmission can be discontinuous, such that there may not be any data frame transmitted in a 20 ms interval aligned to the CDMA System Time.

25 The use of code division multiple access (CDMA) modulation techniques is one of several techniques for facilitating communications in which a large number of system users are present. Other multiple access communication system techniques, such as time division multiple access (TDMA) and frequency division multiple access (FDMA) are known in the
30 art. However, the spread spectrum modulation technique of CDMA has significant advantages over these modulation techniques for multiple access communication systems. The use of CDMA techniques in multiple access

74769-473D

3

communication systems is disclosed in U.S. Patent No. 4,901,307, entitled "SPREAD SPECTRUM MULTIPLE ACCESS COMMUNICATION SYSTEM USING SATELLITE OR TERRESTRIAL REPEATERS," and U.S. Patent No. 5,103,459, entitled "SYSTEM AND METHOD FOR GENERATING SIGNAL
5 WAVEFORMS IN A CDMA CELLULAR TELEPHONE SYSTEM".

CDMA by its inherent nature of being a wideband signal offers a form of frequency diversity by spreading the signal energy over a wide bandwidth.
10 Therefore, frequency selective fading affects only a small part of the CDMA signal bandwidth. Space or path diversity is obtained by providing multiple signal paths through simultaneous links from a mobile user through two or more cell-sites. Furthermore, path diversity may be obtained by exploiting the multipath environment through spread spectrum processing by
15 allowing a signal arriving with different propagation delays to be received and processed separately. Examples of path diversity are illustrated in U.S. Patent No. 5,101,501 entitled "METHOD AND SYSTEM FOR PROVIDING A SOFT HANDOFF IN COMMUNICATIONS IN A CDMA CELLULAR TELEPHONE SYSTEM," and U.S. Patent No. 5,109,390 entitled "DIVERSITY
20 RECEIVER IN A CDMA CELLULAR TELEPHONE SYSTEM".

In a communication system that provides data using a QPSK modulation format, useful information can be obtained by taking the cross
25 product of the I and Q components of the QPSK signal. By knowing the relative phases of the two components, one can determine roughly the velocity of the mobile station in relation to the base station. A description of a circuit for determining the cross product of the I and Q components in a QPSK modulation communication system is disclosed in U.S. Patent No.
30 5,506,865, entitled "PILOT CARRIER DOT PRODUCT CIRCUIT".

74769-473D

4

There has been an increasing demand for wireless communications systems to be able to transmit digital information at high rates. One method for sending high rate digital data from a remote station to a central base station is to allow the remote station to send the data using spread spectrum techniques of CDMA, such as that proposed in U.S. Patent No. 6,396,804 entitled "HIGH DATA RATE CDMA WIRELESS COMMUNICATION SYSTEM".

New methods for supervising the F-DCCH are needed when F-DCCH is in this discontinuous transmission (DTX) mode because the mobile station must now decide whether a received frame is a good frame, a bad frame, or an empty frame (i.e., no transmission), and how to handle the transmission based upon the type of frames received.

15

SUMMARY OF THE INVENTION

A broad aspect of the invention provides a method for supervising a dedicated control channel transmitted in a discontinuous transmission (DTX) mode to a mobile station, comprising: receiving a pilot strength measurement for each pilot signal contained in an active set of base stations; determining an aggregate of said pilot strength measurements; determining an average for said aggregate over a selected time interval; and disabling a remote station transmitter if said average is below a threshold for a designated time (T_1).

In some embodiments, the method further comprises deeming said received transmission terminated if said average is below said threshold for a second designated time (T_2), where $T_2 > T_1$.

10 In some embodiments, the mobile station uses the received pilot
strength (E_c/I_o) of pilots in the Active Set to perform F-DCCH supervision.
The method aggregates the E_c/I_o of all pilots in the Active Set and averages
them over a designated time interval. If this average aggregated value
(AAV) is below a threshold for a specified amount of time, then the mobile
15 station disables its transmitter. If the AAV continues below the threshold
for a longer specified period of time, then the mobile station disables its
transmitter, if not already disabled, and declares the Forward Traffic
Channel as lost.

20 As readily recognizable to one skilled in the art, the invention also
provides a number of advantages and benefits that will become apparent
after reviewing the following description of the invention.

BRIEF DESCRIPTION OF THE DRAWINGS

25 Some of the features, objects, and advantages of the present invention
are set forth in the detailed description below and when taken in
conjunction with the drawings in which like reference characters identify
correspondingly throughout, and wherein:

30 FIGURE 1 is a diagram illustrating the elements of a wireless
communications system;

74769-473D

6

FIGURE 2 is a block diagram of the base station of the present invention; and

FIGURE 3 is a block diagram of the remote station of the present invention.

5

DETAILED DESCRIPTION OF VARIOUS EMBODIMENTS

In FIG. 1, base station 2 transmits forward link signals 6 to mobile station 4. Mobile station 4 transmits reverse link signals 8 to base station 2. In the exemplary embodiment, forward link signals 6 and reverse link signals 8 are code division multiple access (CDMA) communications signals as contemplated by the Telecommunications Industry Association in the candidate submission to the International Telecommunications Union (ITU) entitled "The cdma2000 ITU-R RTT Candidate Submission" and which has been further refined in the Interim Standard Draft Text entitled
10 signals 8 are code division multiple access (CDMA) communications signals as contemplated by the Telecommunications Industry Association in the candidate submission to the International Telecommunications Union (ITU) entitled "The cdma2000 ITU-R RTT Candidate Submission" and which has been further refined in the Interim Standard Draft Text entitled
15 "Proposed Ballot Text for cdma2000 Physical Layer".

Turning to FIG. 2, the elements necessary for the transmission of the F-DCCH on forward link signal 6 and for reception of reverse link signal 8 is illustrated in greater detail. Messages for transmission on the F-DCCH are generated in F-DCCH message generator (DCCH MSG GEN) 100. These
20 messages may include rate scheduling messages, handoff direction messages, and response messages as discussed below. The F-DCCH is a DTX channel that is transmitted when there is a message or messages to be communicated from a base station 2 to the mobile station 4.

A message is provided to F-DCCH processing element 102. F-DCCH
25 processing element 102 performs the necessary pre-processing and encoding of the F-DCCH message and channelizes the message for transmission on the F-DCCH of forward link signal 6. The F-DCCH message is provided to cyclic redundancy check (CRC) and tail bit generator 104. In response, CRC and tail bit generator 104 generates a set of CRC bits in accordance with the
30 bits in the F-DCCH message and appends the CRC bits to the F-DCCH message. CRC and tail bit generator 104 then appends a series of tail bits to

74769-473D

7

clear the memory of a decoder at the receiver and provides the resulting packet to encoder 106.

In the exemplary embodiment, encoder 106 is a convolutional encoder, the design and implementation of which is well known in the art. However, the present invention is equally applicable to other types of encoders, such as block encoders and turbo encoders. The encoded symbols are provided to interleaver 108. Interleaver 108 reorders the symbols in a predetermined fashion in order to provide time diversity into the transmission of the F-DCCH message. The interleaving operation helps to spread the results of an error burst over the packet in order to improve the performance of the decoder at the receiver. These "error bursts" - bit or symbol errors that occur consecutively - are typical in wireless communications systems.

The interleaved symbols are provided to power control puncturing element 109. Puncturing element 109 receives reverse link power control bits and punctures the power control bits into the interleaved symbol stream. The power control bits are transmitted to mobile station 4 and are used to adjust the transmission energy of reverse link signal 8.

The symbols from puncturing element 109 are provided to de-multiplexer 110 that alternatively outputs the symbols onto different processing paths. The first output of de-multiplexer 110 is provided to spreading element 112a and the next output of de-multiplexer 110 is provided to spreader 112b, and so on. Spreaders 112 spread the de-multiplexed symbols in accordance with an orthogonal spreading function W_{DCCH} . Orthogonal spreading is well known in the art and a preferred embodiment of spreaders 112 is disclosed in the aforementioned U.S. Patent No. 5,103,459. The spread signals are provided to complex PN spreader 116.

In addition to the dedicated control channel, base station 2 transmits a pilot channel to allow remote station 4 to coherently demodulate the received F-DCCH. Pilot symbols, typically an all-ones sequence, are provided to spreading element 114. The pilot symbols are spread in

74769-473D

8

accordance with orthogonal spreading sequence W_{pilot} , which is orthogonal to spreading sequence W_{DCCH} .

The spread signals from spreading elements 112 and 114 are provided to complex PN spreader 116. Complex PN spreader 116 spreads the signals from spreaders 112 and 114 in accordance with two pseudonoise (PN) sequences PN_I and PN_Q . Complex PN spreading is well known in the art and is described in detail in the cdma2000 candidate submission and the IS-2000 draft specification. The complex PN spread signal is provided to transmitter (TMTR) 118. TMTR 118 up-converts, amplifies, and filters the spread signals for transmission through antenna 120 as forward link signal 6. In the exemplary embodiment, TMTR 118 modulates the signal in accordance with a QPSK modulation format.

Turning to FIG. 3, forward link signal 6 is received at antenna 200 and provided through duplexer 202 to receiver (RCVR) 204. RCVR 204 down-converts, amplifies, and filters forward link signal 6. RCVR 204 demodulates forward link signal 6 in accordance with a QPSK demodulation format and outputs the in-phase and quadrature-phase signals to complex PN despreader 206. Complex PN despreader 206 despreads the received signal in accordance with the two pseudonoise sequences used to spread the signal (PN_I and PN_Q). The despread complex PN signals are provided to pilot filter 208. Pilot filter 208 further despreads the signal in accordance with the orthogonal spreading sequence W_{pilot} . The despread pilot symbols are provided to E_c/I_o calculator 214 and dot product circuit 216.

The complex PN despread signals are also provided to demodulator 210. Demodulator 210 demodulates the PN despread signals in accordance with the orthogonal spreading code W_{DCCH} . The despread signals are then provided to dot product circuit 216. Dot product circuit 216 computes the dot product of the F-DCCH and the pilot channel. Because both the pilot channel and dedicated control channel traverse the same propagation path they will experience the same phase shifts. By computing the dot product of the pilot and DCCH channels the result is a scalar set of magnitudes with the

74769-473D

9

channel induced phase ambiguities removed. A preferred implementation of dot product circuit 216 is described in the aforementioned U.S. Patent No. 5,506,865.

The resultant demodulated symbols from dot product circuit 216 are provided to de-interleaver/decoder 218 and empty frame detector 220. De-interleaver/decoder 218 de-interleaves and decodes the F-DCCH message and provides an estimate of the message or a signal indicating the declaration of a bad frame to DCCH control processor 222. There are a number of ways that a bad frame can be detected. A first is to determine whether the CRC when generated locally at remote station 4 check with the decoded CRC bits. A second is to compute the symbol error rate of the received symbols by comparing the received encoded symbols with a set of locally generated re-encoded symbols based on the decoded bits.

The demodulated symbols from dot product circuit 216 are also provided to empty frame detector 220. Empty frame detector 220 computes the signal to noise ratio of the demodulated symbols and compares the measured signal to noise ratio to a threshold. If the signal to noise ratio is below the threshold an empty frame is declared. It should be noted that there are other methods of determining an empty frame, any of which may be employed without leaving the scope of the present invention. A method and apparatus for detecting empty frames is disclosed in co-pending U.S. Patent No. 6,347,080, entitled "ENERGY BASED COMMUNICATION RATE DETECTION SYSTEM AND METHOD".

25

Data frames that are not empty are provided to DCCH control processor 222, which extracts the punctured power control commands and sends a signal to transmitter 232 adjusting the transmission energy of reverse link signal 8 in response. The loss of this power control command stream results in an inability to control the power of reverse link signal 8, which in turn increases the potential for jamming the reverse link.

30

74769-473D

10

In a first embodiment of the present invention, the DCCH control processor 222 receives an indication from decoder 218 or detector 220 that a frame is either good, bad, or empty. Three counters: CNT1 224, CNT2 226, and CNT3 227, are initialized to zero at the beginning of a call. If the received frame is a good frame, then CNT1 224 is reset to zero and CNT2 226 is incremented by one. If the received frame is declared a bad frame, then CNT1 224 is incremented and CNT2 226 is reset to zero. If the frame is declared empty then values of CNT1 224 and CNT2 226 remain unchanged, and the value of CNT3 226 is incremented. If the value of CNT1 224 reaches a threshold TH1 then DCCH control processor 222 sends a signal to transmitter 232 disabling the transmitter (i.e., output power is turned off). Thereafter, if the value of CNT2 226 reaches a threshold TH2, then DCCH control processor 222 sends a signal to transmitter 232 re-enabling the transmitter. Similarly, if the value of CNT3 227 reaches a threshold TH4, then DCCH control processor 222 sends a signal to transmitter 232 disabling the transmitter. If the value of CNT3 227 reaches a threshold TH5, then DCCH control processor 222 sends a signal to transmitter 232 disabling the transmitter, if not already disabled, and declares a loss of the Forward Traffic Channel (i.e., terminate the call.)

In a second embodiment, base station 2 transmits a frame, referred to herein as a supervisory frame, every N-second interval, if there is no data frame to be transmitted on the F-DCCH at that time. The supervisory frame contains pre-defined bits known to the mobile station and is transmitted at the lowest data rate that has been negotiated between base station 2 and mobile station 4. Referring to FIG. 2, timer 134 tracks the N-second intervals and at the expiration of the interval sends a signal to control processor 132. Control processor 132 determines whether there is a message for transmission and if not provides a signal to message generator 100 to generate a supervisory frame. The supervisory frame is transmitted on the F-DCCH channel as described with respect to other DCCH messages previously. Mobile station 4 then performs F-DCCH supervision on non-empty frames transmitted at such preset time in a way similar to that

defined in IS-95, with potentially different value for various thresholds. Mobile station 4 may also include other non-empty frames received for supervision purpose in addition to these periodic frames. In another embodiment, the mobile station knows that a supervisory frame is transmitted every N-seconds. If a good frame is not received within N-seconds, CNT1 is incremented. This method may be used in conjunction with the first embodiment discussed above.

In a third embodiment, base station 2 transmits a frame, referred to herein as a supervisory frame, whenever the number of consecutive empty frames exceeds a threshold. In a preferred embodiment, the supervisory frame contains pre-defined bits known to the mobile station and is transmitted at the lowest data rate that has been negotiated between base station 2 and mobile station 4. Referring to FIG. 2, control processor 132 tracks the number of consecutive empty frames in accordance with signals from message generator 100. When the number of consecutive empty frames exceeds the threshold values, then control processor sends a signal to issue a supervisory frame to message generator 100 to generate the supervisory frame. The supervisory frame is transmitted on the F-DCCH channel as described with respect to other F-DCCH messages. Mobile station 4 then performs F-DCCH supervision on all non-empty frames in a way similar to that defined in IS-95, with potentially different value for various thresholds. In another embodiment, control processor 132 tracks the number of consecutive empty frames in a given time interval N. If a good frame is not received within the time interval N, then CNT1 is incremented and the invention proceeds as discussed above.

In a fourth exemplary embodiment, mobile station 4 transmits a request message that requires reply from base station 2 when the number of consecutive empty frames detected exceeds a threshold. The reply can simply be an acknowledgement that the request message was received. Referring to FIG. 3, control processor 222 receives an indication as whether a frame is empty from empty frame detector 220. In this embodiment, counter 224 tracks the number of consecutive empty frame and is reset

74769-473D

12

when a bad frame or good frame is detected. When the count of consecutive empty frames exceeds a threshold, control processor 222 sends a signal to message generator (MSG GEN) 228, which in response generates the request message. The request message is encoded in encoder 228, modulated in
5 modulator 230, and up-converted, amplified and filtered onto a predetermined channel of reverse link signal 8. The request message can be any existing message that is already defined in the standard, which does not cause any base station action besides sending an acknowledgement. For example, the Power Measurement Report Message. The request message
10 can also be a special message that causes the base station 2 to transmit a supervisory frame on the F-DCCH.

Turning to FIG. 2, the request message is received on antenna 8 and provided to receiver 124 which down-converts, amplifies and filters reverse link signal 8 and provides the received signal to demodulator 126.
15 Demodulator 126 demodulates the signal and decoder 128 decodes the demodulated symbols providing the request message to control processor 132. In response, control processor 132 determines if a message is queued to be transmitted on the F-DCCH and if not sends a signal requesting that message generator 100 generate a message for transmission on the F-DCCH.
20 In the exemplary embodiment, the message generated by generator 100 is simply an acknowledgement of the receipt of the request message from mobile station 4.

The mobile station knows that the base station will reply. Therefore, in another embodiment, if the mobile station does not receive a good frame
25 within an interval of T seconds after the request message is sent, CNT1 is incremented and the invention proceeds as discussed above. In another version, the mobile station contains an acknowledgement counter that counts the number of times the mobile station attempts to transmit the request message. If a response from the base station is not received within K
30 number of attempts, the mobile station disables its transmitter, if it is not already disabled, and declares a loss of the Forward Traffic Channel (i.e., the call is terminated).

74769-473D

13

In a fifth embodiment, mobile station 4 transmits a request message which requires a reply from base station 2 when the number of empty frames detected within a predetermined number of received frames exceeds a threshold, regardless of whether or not the empty frames are consecutive. Referring to FIG. 3, control processor 222 receives an indication as to whether a frame is empty from empty frame detector 220. Counter 224 tracks the number of empty frames in a moving accumulator fashion. When the count of empty frames in a predetermined number of received frames exceeds a threshold, control processor 222 sends a signal to message generator (MSG GEN) 228, which in response generates a request message. The request message is encoded in encoder 228, modulated in modulator 230, and up-converted, amplified and filtered onto a predetermined channel of reverse link signal 8.

Turning to FIG. 2, the request message is received on antenna 8 and provided to receiver 124 which down-converts, amplifies and filters reverse link signal 8 and provides the received signal to demodulator 126. Demodulator 126 demodulates the signal and decoder 128 decodes the demodulated symbols providing the request message to control processor 132. In response, control processor 132 determines if a message is queued to be transmitted on the F-DCCH and if not sends a signal requesting that message generator 100 generate a message for transmission on the F-DCCH. In the exemplary embodiment, the message generated by generator 100 is simply an acknowledgement of the receipt of the request message.

The mobile station knows that the base station will reply. If a reply is not received within T seconds after sending the message, then CNT1 is incremented. In another embodiment, the mobile station contains an acknowledgement counter that counts the number of times the mobile station attempts to transmit the request message. If a reply is not received after K attempts at sending the message, the mobile station disables its transmitter, if it is not already disabled, and declares a loss of the Forward Traffic Channel (i.e., the call is terminated).

74769-473D

14

In a sixth embodiment, mobile station 4 uses the received pilot strength (E_c/I_o) of pilots in the Active Set to perform F-DCCH supervision. If the aggregated Active Set pilot E_c/I_o is above a preset threshold, mobile station 4 considers the data, if sent in that frame, will be received correctly --- therefore, a good frame. Otherwise, mobile station 4 considers the frame as bad. A supervision rule with the above definition of good frame and bad frame similar to that specified in IS-95 can then be used, with either the same thresholds or modified ones.

10 Referring to FIG. 3, the signal to noise ratio (E_c/I_o) of the received pilot symbols is computed in E_c/I_o calculator 214. The E_c/I_o value for the pilot signal of forward link signal 6 is combined with the E_c/I_o value of pilots from other base stations in the Active Set of mobile station 4 to provide an aggregate E_c/I_o . The Active Set of base stations is the set of base stations currently communicating with mobile station 4. The aggregate pilot E_c/I_o is provided to control processor 222 that compares the aggregate E_c/I_o to a threshold value. If the aggregate E_c/I_o exceeds a threshold a good frame is declared and if the aggregate E_c/I_o is less than the threshold a bad frame is declared. This allows mobile station 4 to infer a received frame, if non-
15 empty, is a good frame or a bad frame without decoding the frame. Based on these counts, mobile station 4 will enable or disable transmitter 232 as described previously.

In another embodiment, the aggregated E_c/I_o is averaged over certain specified time intervals. If the average aggregated E_c/I_o is below a threshold TH_x for a first time period (for example, 220 ms), then the mobile station will disable its transmitter. Thereafter, if the average aggregated E_c/I_o is above a threshold Th_y for a second time period (for example, 40 ms), then the mobile station will re-enable its transmitter. However, if the average aggravated pilot E_c/I_o remains below the threshold TH_x for a much longer
25 third time period (for example, 5 seconds), then the mobile station will disable its transmitter, if not already disabled, and declare a loss of the Forward Traffic Channel (i.e., terminate the call.) Although suggested
30

74769-473D

15

lengths for the time periods are given, the time periods are adaptive, and may be longer or shorter in duration depending upon the application.

The previous description of the various embodiments is provided to enable any person skilled in the art to make or use the present invention.

5 The various modifications to these embodiments will be readily apparent to those skilled in the art, and the generic principles defined herein may be applied to other embodiments without the use of the inventive faculty. Thus, the present invention is not intended to be limited to the embodiments shown herein but is to be accorded the widest scope consistent
10 with the principles and novel features disclosed herein.

74769-473D

16

CLAIMS:

1. A method for supervising a dedicated control channel transmitted in a discontinuous transmission (DTX) mode to a mobile station, comprising:

5 receiving a pilot strength measurement for each pilot signal contained in an active set of base stations;

determining an aggregate of said pilot strength measurements;

10 determining an average for said aggregate over a selected time interval; and

disabling a remote station transmitter if said average is below a threshold for a designated time (T_1).

2. The method recited in claim 1, further comprising
15 deeming said received transmission terminated if said average is below said threshold for a second designated time (T_2), where $T_2 > T_1$.

SMART & BIGGAR
OTTAWA CANADA
PATENT AGENTS

74769-473D

1/3

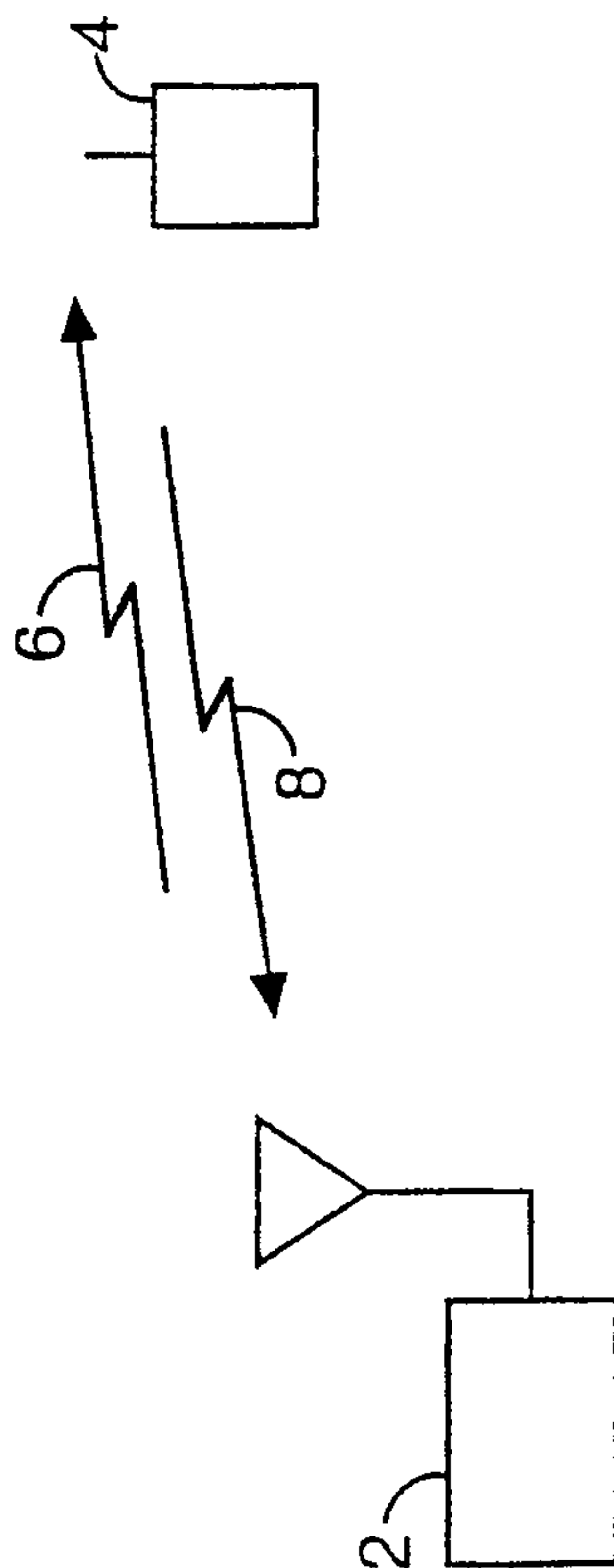

FIG. 1

74769-473D

2/3

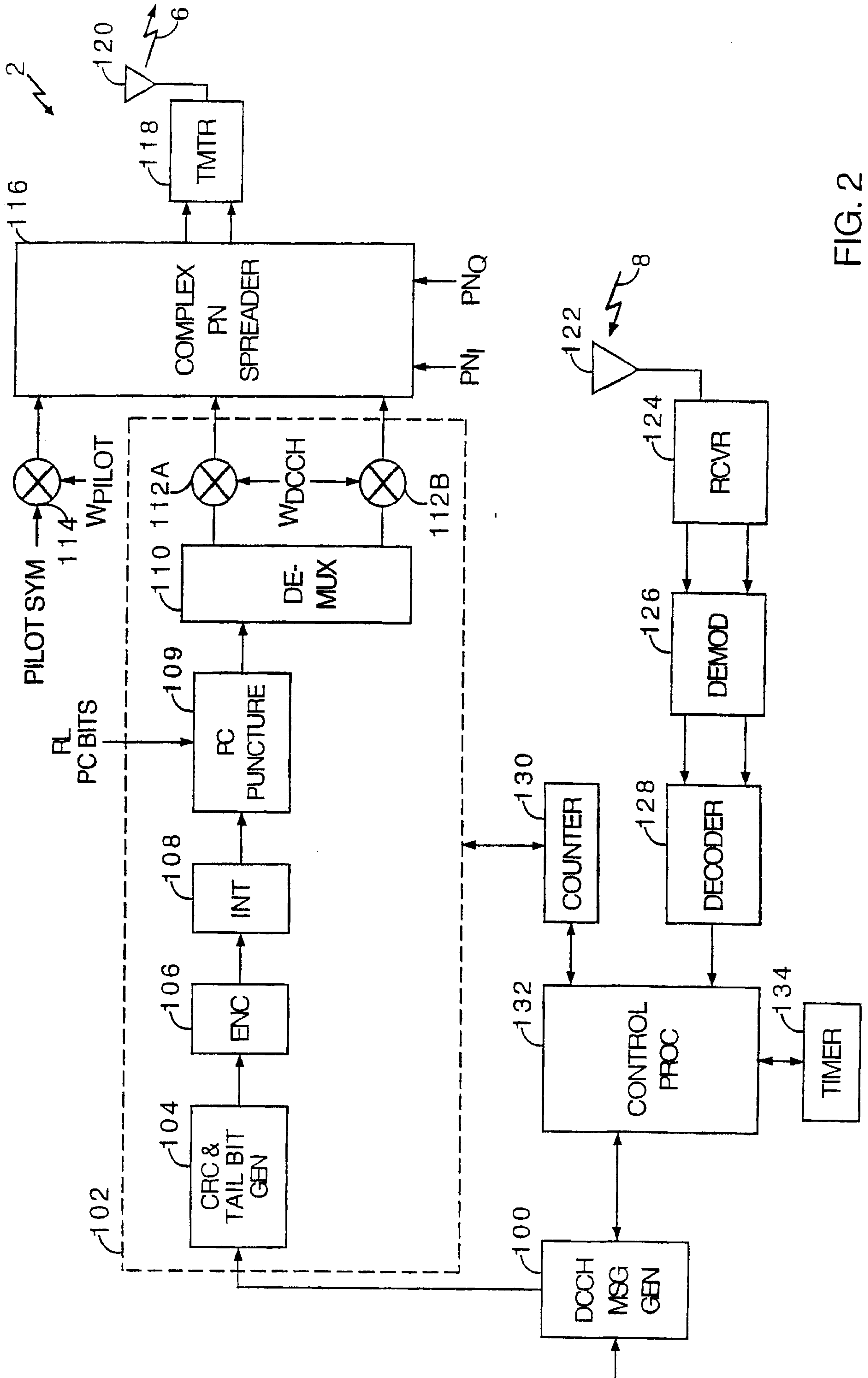

FIG. 2

74769-473D

3/3

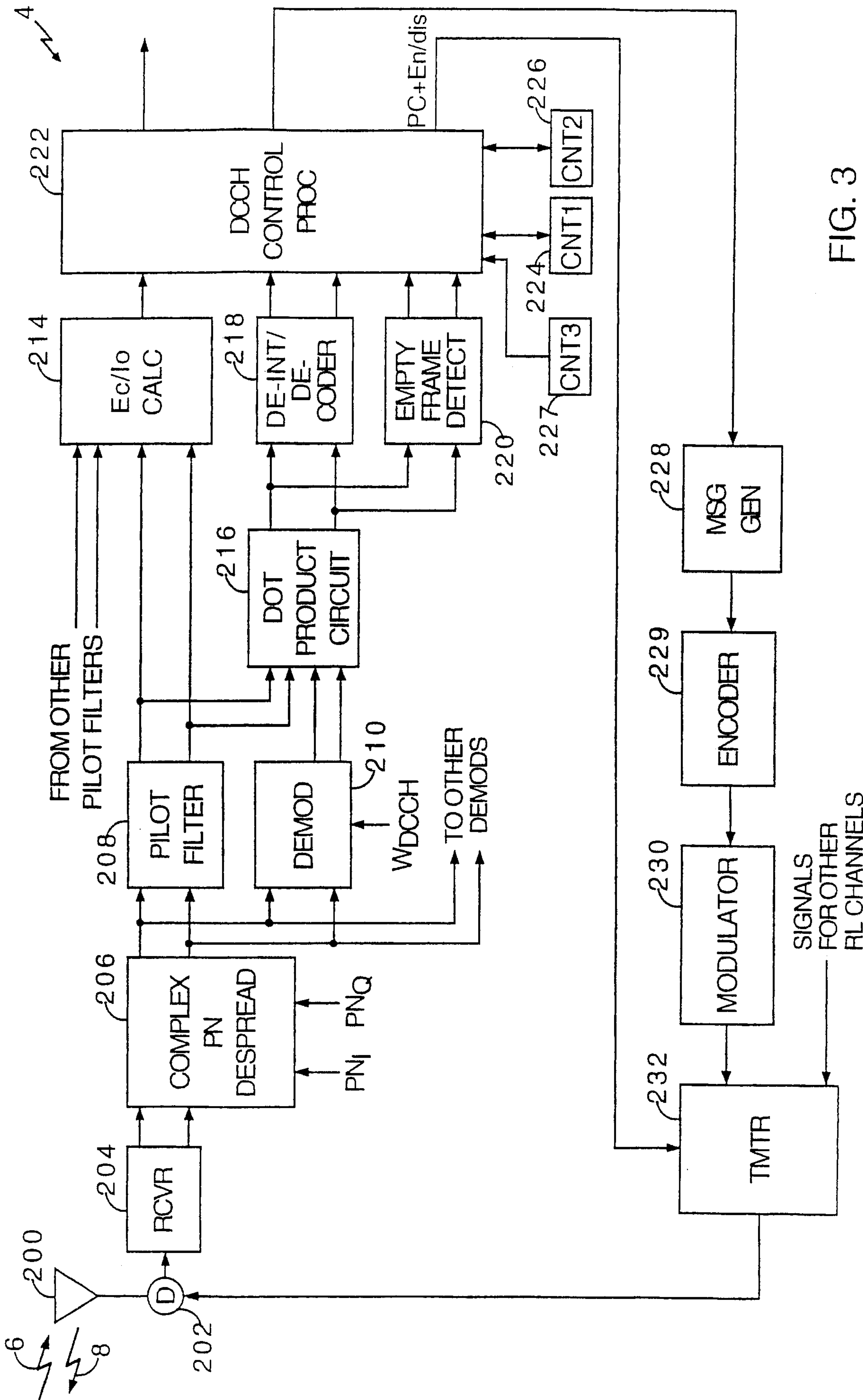

FIG. 3

