

E. M. SAUNDERS.
MANGLE ROLL.
APPLICATION FILED JAN. 23, 1915.

1,154,731.

Patented Sept. 28, 1915.

FIG. 1.

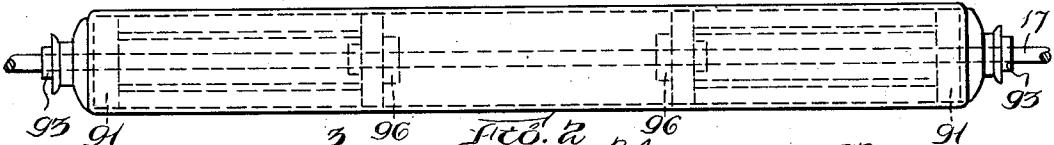

FIG. 2.

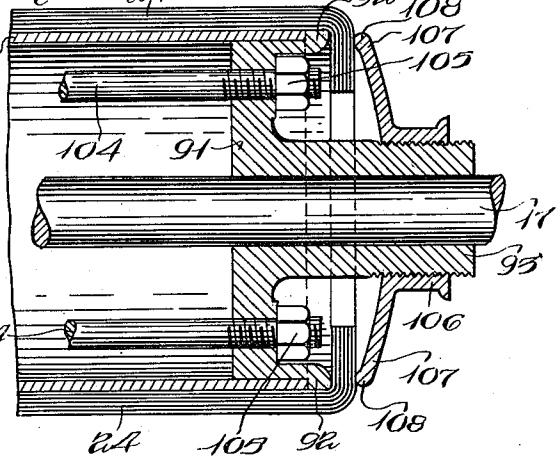
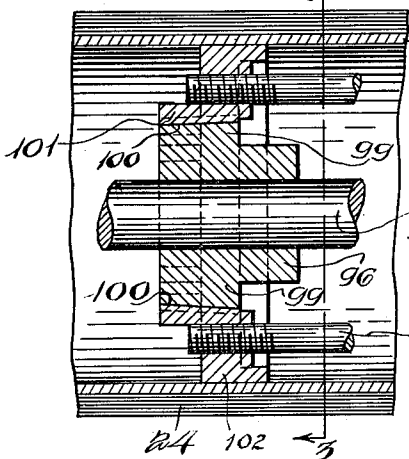
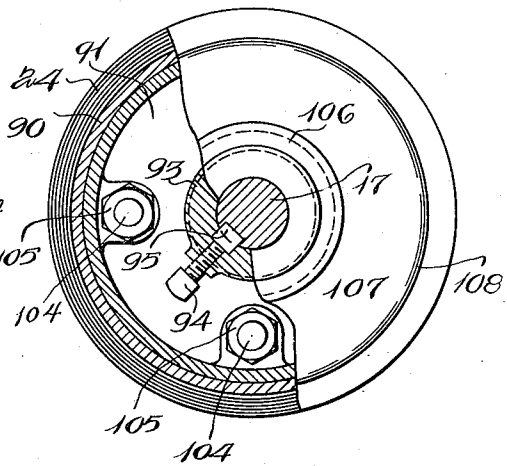
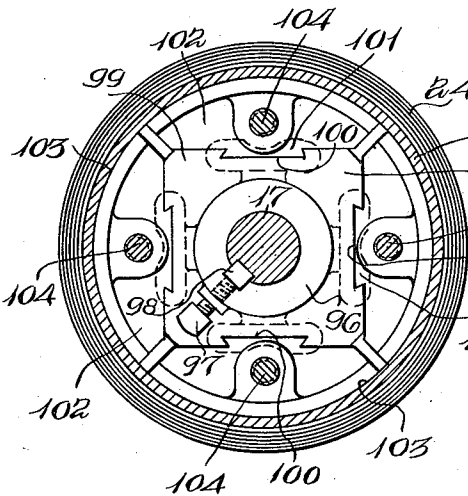

FIG. 4.

FIG. 5.



Witnesses:
P. N. Pizzetti
E. P. Brannen

Inventor:
Emily M. Saunders
By Wright Brown Lundy May
Attorneys

UNITED STATES PATENT OFFICE.

EMILY M. SAUNDERS, OF BOSTON, MASSACHUSETTS.

MANGLE-ROLL.

1,154,731.

Specification of Letters Patent. Patented Sept. 28, 1915.

Application filed January 23, 1915. Serial No. 3,914.

To all whom it may concern:

Be it known that I, EMILY M. SAUNDERS, a citizen of the United States, and resident of Jamaica Plain, Boston, in the county of Suffolk and State of Massachusetts, have invented certain new and useful Improvements in Mangle-Rolls, of which the following is a specification.

This invention relates to cloth-covered ironing rolls for mangles, said rolls being adapted to cooperate with heated ironing chambers having concave polished faces in close proximity to the peripheries of the rolls, the goods being ironed passing between the rolls and the ironing chambers, as shown in the application of William A. Saunders, filed Feb. 2, 1914, Serial Number 815,881.

The object of the invention is to provide an improved construction affording uniform strength and rigidity of all parts of the cloth supporting surface of the roll, and enabling the cloth covering to be conveniently secured for use and released for removal.

Of the accompanying drawings forming a part of this specification: Figure 1 is a side elevation of an ironing roll embodying the invention; Fig. 2 is a fragmentary longitudinal section of the roll shown by Fig. 1; Fig. 3 is a section on line 3-3 of Fig. 2; Fig. 4 is an end elevation of the roll, one side being shown in section.

My improved ironing roll is constructed as shown in detail by Figs. 1, 2, 3 and 4, which may be understood to represent one of a number of rolls with which a mangle is provided as shown by the above mentioned application. The body of the roll is composed of a hollow metal cylinder 90 and heads 91 inserted in the ends of the cylinder and having flanges 92 bearing on said ends. The heads 91 have hubs 93 attached by set screws 94 and keys 95 (Fig. 4) to the shaft 17. Said shaft is provided within the cylinder 90 with hubs 96 attached to the shaft by set screws 97 and keys 98 (Fig. 3), the hubs 96 being uniformly spaced from each other

and from the heads 91, as indicated by Fig. 1. Each hub 96 has a head or enlargement 99 provided in each of its four sides with dovetail guides 100, which are inclined relatively to the shaft 17 as shown by Fig. 2. With said guides are engaged dovetail slides 101 formed on supporting blocks 102 having segmental outer faces 103 fitting the internal surface of the cylinder 90. The supporting blocks have tapped orifices engaging the threaded inner ends of tension rods 104, the threaded outer ends of which pass freely through holes in the heads 91, and are provided with nuts 105 bearing on the outer sides of the heads 91. The operation of tightening said nuts causes the rods 104 to draw the supporting blocks 102 toward the heads 91, said blocks being at the same time forced radially outward by the inclined guides 100, and caused to bind firmly against the inner surface of the cylinder 90. The hubs 96 and supporting blocks 102 constitute expansible heads adapted to be supported by the shaft while contracted, and expanded after the parts are assembled. The expanded heads firmly support the cylinder 90 at points between the outer heads 91, so that the cylinder is rigid from end to end and cannot be bent or sprung by the pressure of unusually thick parts of the goods against the periphery of the roll.

The hubs 93 are externally threaded and with their threaded portions are engaged sleeves 106 having clamping flanges 107, the beaded edges 108 of which confine the inwardly bent portions of the cloth covers 24 against the beveled edges 109 of the heads 91. The rotation of the sleeves 106 therefore causes the flanges 107 to either secure or release the ends of the cloth cover.

Having described the invention, I claim:
1. In a mangle, a roll composed of a shaft, end heads secured to the shaft, intermediate expansible heads secured to the shaft, a hollow cylindrical body supported by said heads, means for expanding the intermediate heads against the inner surface of the body, and a cloth cover on said body.

2. In a mangle, a roll composed of a shaft, end heads secured to the shaft, intermediate expansible heads secured to the shaft and comprising hubs having inclined guides and segmental supporting blocks movable on said guides, tension rods engaged with said end heads, and supporting blocks, and means for adjusting said rods endwise to

press the supporting blocks outwardly against the cylindrical body.

In testimony whereof I have affixed my signature, in presence of two witnesses.

EMILY M. SAUNDERS.

Witnesses:

C. F. BROWN,

P. W. PEZZETTI.