



(86) **Date de dépôt PCT/PCT Filing Date:** 2004/03/26
 (87) **Date publication PCT/PCT Publication Date:** 2004/10/14
 (45) **Date de délivrance/Issue Date:** 2016/10/18
 (85) **Entrée phase nationale/National Entry:** 2005/09/20
 (86) **N° demande PCT/PCT Application No.:** US 2004/009297
 (87) **N° publication PCT/PCT Publication No.:** 2004/086944
 (30) **Priorités/Priorities:** 2003/03/27 (US60/458,854);
 2003/06/11 (US60/478,035); 2003/07/24 (US60/490,082);
 2004/02/25 (US10/787,532)

(51) **Cl.Int./Int.Cl. A61B 18/18** (2006.01)

(72) **Inventeurs/Inventors:**
 MALECKI, WILLIAM, US;
 FRANCIS, DAN, US;
 HORNE, KENNETH, US;
 DEEM, MARK E., US;
 GIFFORD, HANSON S., III, US;
 ALEJANDRO, JOSE, US

(73) **Propriétaire/Owner:**
 TERUMO KABUSHIKI KAISHA, JP

(74) **Agent:** FETHERSTONHAUGH & CO.

(54) **Titre : DISPOSITIFS ET PROCÉDES FONDES SUR L'APPLICATION D'UNE ENERGIE POUR LE TRAITEMENT DU FORAMEN OVALE PERSISTANT**

(54) **Title: ENERGY BASED DEVICES AND METHODS FOR TREATMENT OF PATENT FORAMEN OVALE**

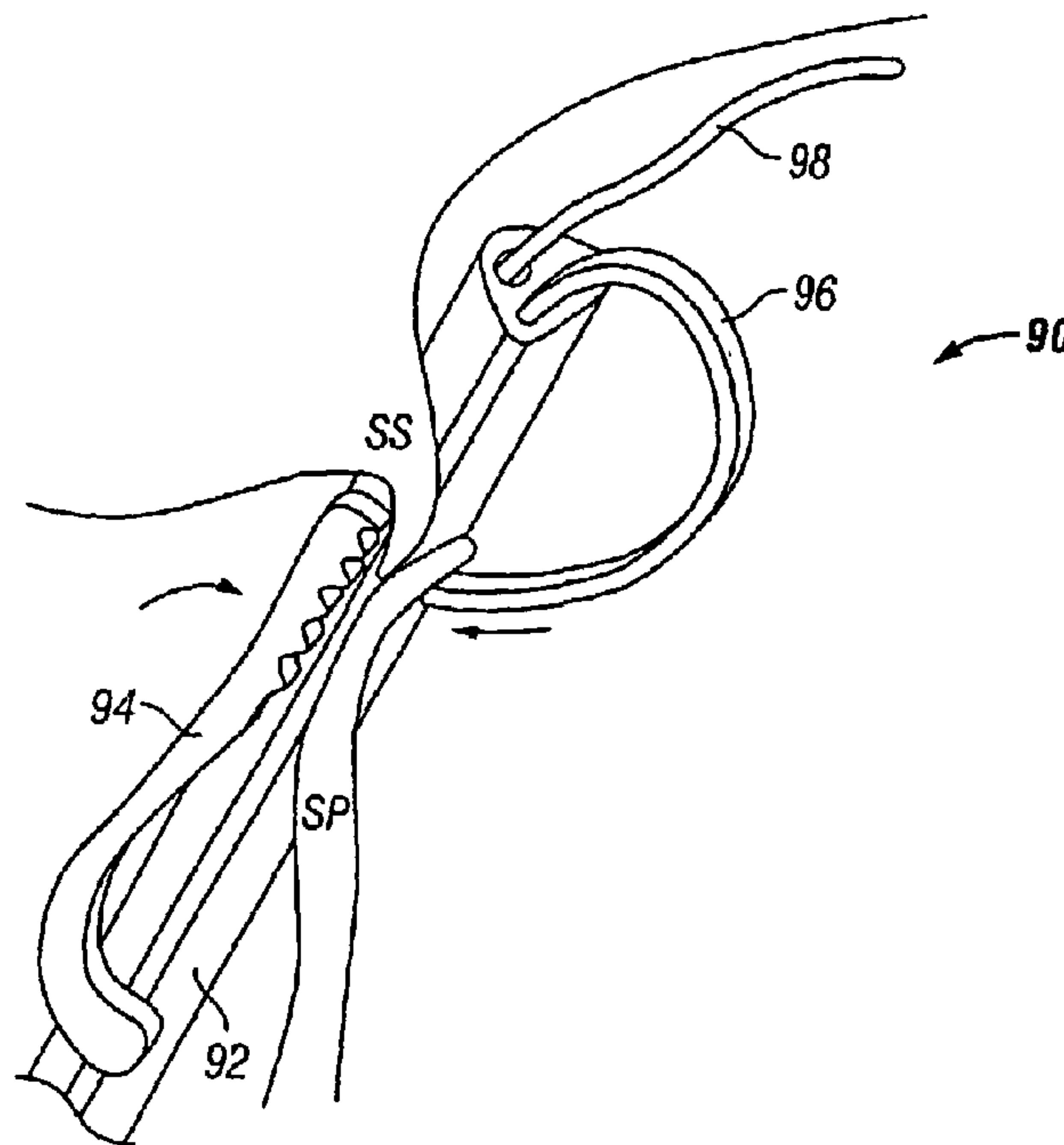

(57) **Abrégé/Abstract:**

Methods, devices and systems for treating patent foramen ovale (PFO) involve advancing a catheter device to a position in a heart for treating a PFO, bringing tissues adjacent the PFO at least partially together, and applying energy to the tissues to substantially close the PFO acutely. Catheter devices generally include an elongate catheter body, at least one tissue apposition member at or near the distal end for bringing the tissues together, and at least one energy transmission member at or near the distal end for applying energy to the tissues. In some embodiments, the tissue apposition member(s) also act as the energy transmission member(s). Applied energy may be monopolar or bipolar radiofrequency energy or any other suitable energy, such as laser, microwave, ultrasound, resistive heating or the like.

(12) INTERNATIONAL APPLICATION PUBLISHED UNDER THE PATENT COOPERATION TREATY (PCT)

(19) World Intellectual Property
Organization
International Bureau



(43) International Publication Date
14 October 2004 (14.10.2004)

PCT

(10) International Publication Number
WO 2004/086944 A3

- (51) International Patent Classification⁷: **A61B 18/18**
- (21) International Application Number: PCT/US2004/009297
- (22) International Filing Date: 26 March 2004 (26.03.2004)
- (25) Filing Language: English
- (26) Publication Language: English
- (30) Priority Data:
60/458,854 27 March 2003 (27.03.2003) US
60/478,035 11 June 2003 (11.06.2003) US
60/490,082 24 July 2003 (24.07.2003) US
10/787,532 25 February 2004 (25.02.2004) US
- (71) Applicant (for all designated States except US): **CIERRA INC.** [US/US]; 199 Jefferson Drive, Menlo Park, CA 94025 (US).
- (72) Inventors; and
(75) Inventors/Applicants (for US only): **MALECKI, William** [US/US]; 510 Clayton Street, San Francisco, CA 94117 (US). **FRANCIS, Dan** [US/US]; 1600 Villa Street, Apartment 392, Mountain View, CA 94941 (US). **HORNE, Kenneth** [US/US]; 926 Bautista Court, Palo Alto, CA 94303 (US). **DEEM, Mark, E.** [US/US]; 685 Sierra Avenue, Mountain View, CA 94041 (US). **GIFFORD, Hanson, S., III** [US/US]; 3180 Woodside Road, Woodside, CA 94062 (US). **ALEGANDRO, Jose** [US/US]; 617 Arcadia Terrace, Unit 101, Sunnyvale, CA 94087 (US).
- (74) Agents: **SMITH, Scott, M.** et al.; Townsend and Townsend and Crew LLP, Two Embarcadero Center, 8th Floor, San Francisco, CA 94111-3834 (US).
- (81) Designated States (unless otherwise indicated, for every kind of national protection available): AE, AG, AL, AM, AT, AU, AZ, BA, BB, BG, BR, BW, BY, BZ, CA, CH, CN, CO, CR, CU, CZ, DE, DK, DM, DZ, EC, EE, EG, ES, FI,

[Continued on next page]

(54) Title: ENERGY BASED DEVICES AND METHODS FOR TREATMENT OF PATENT FORAMEN OVALE

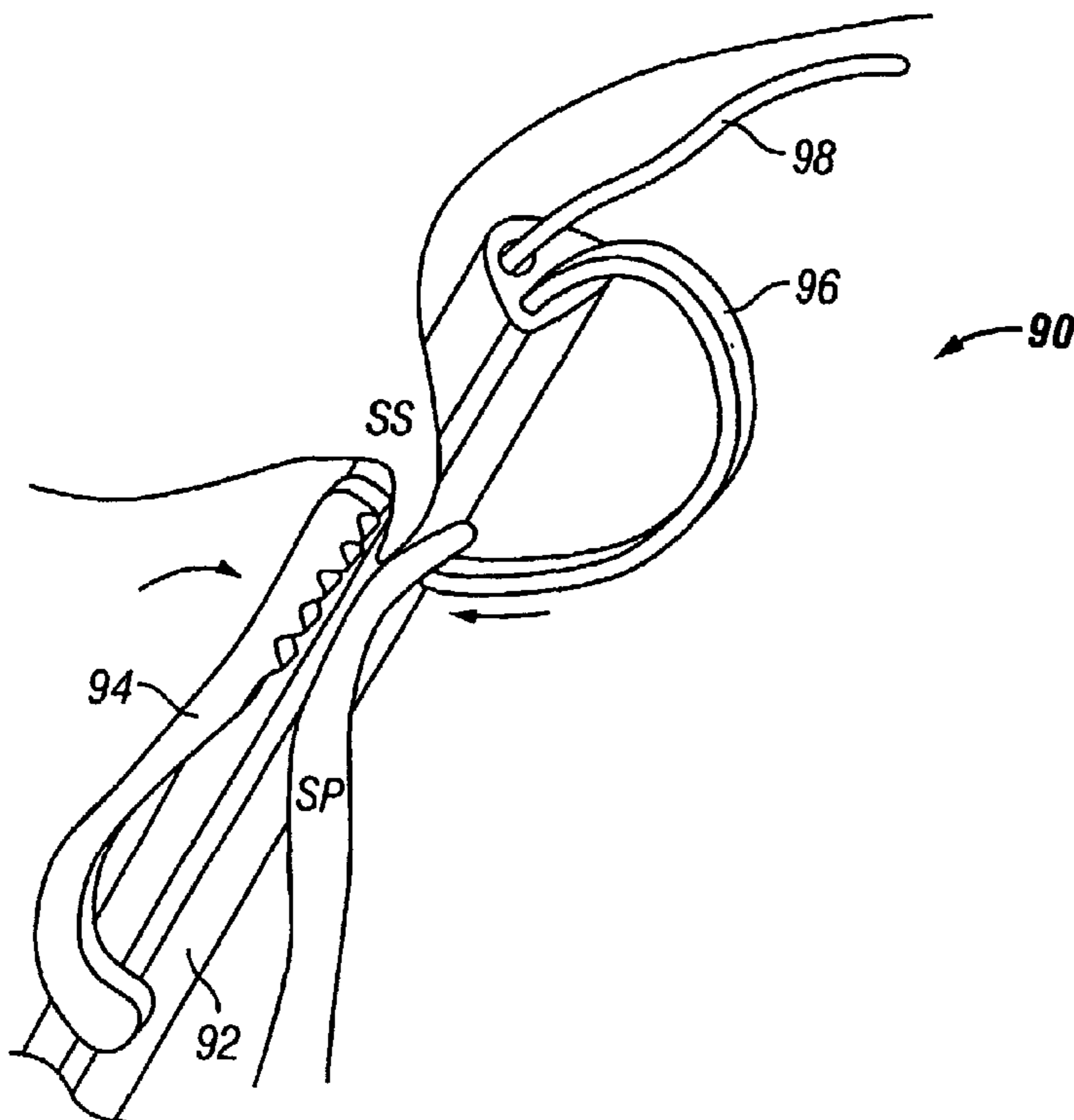

(57) Abstract: Methods, devices and systems for treating patent foramen ovale (PFO) involve advancing a catheter device to a position in a heart for treating a PFO, bringing tissues adjacent the PFO at least partially together, and applying energy to the tissues to substantially close the PFO acutely. Catheter devices generally include an elongate catheter body, at least one tissue apposition member at or near the distal end for bringing the tissues together, and at least one energy transmission member at or near the distal end for applying energy to the tissues. In some embodiments, the tissue apposition member(s) also act as the energy transmission member(s). Applied energy may be monopolar or bipolar radiofrequency energy or any other suitable energy, such as laser, microwave, ultrasound, resistive heating or the like.

WO 2004/086944 A3

WO 2004/086944 A3

GB, GD, GE, GH, GM, HR, HU, ID, IL, IN, IS, JP, KE, KG, KP, KR, KZ, LC, LK, LR, LS, LT, LU, LV, MA, MD, MG, MK, MN, MW, MX, MZ, NA, NI, NO, NZ, OM, PG, PH, PL, PT, RO, RU, SC, SD, SE, SG, SK, SL, SY, TJ, TM, TN, TR, TT, TZ, UA, UG, US, UZ, VC, VN, YU, ZA, ZM, ZW.

(84) Designated States (*unless otherwise indicated, for every kind of regional protection available*): ARIPO (BW, GH, GM, KE, LS, MW, MZ, SD, SL, SZ, TZ, UG, ZM, ZW), Eurasian (AM, AZ, BY, KG, KZ, MD, RU, TJ, TM), European (AT, BE, BG, CH, CY, CZ, DE, DK, EE, ES, FI, FR, GB, GR, HU, IE, IT, LU, MC, NL, PL, PT, RO, SE, SI, SK,

TR), OAPI (BF, BJ, CF, CG, CI, CM, GA, GN, GQ, GW, ML, MR, NE, SN, TD, TG).

Published:

- *with international search report*
- *before the expiration of the time limit for amending the claims and to be republished in the event of receipt of amendments*

(88) Date of publication of the international search report:

9 June 2005

For two-letter codes and other abbreviations, refer to the "Guidance Notes on Codes and Abbreviations" appearing at the beginning of each regular issue of the PCT Gazette.

ENERGY BASED DEVICES AND METHODS FOR TREATMENT OF PATENT FORAMEN OVALE

5 [0001]

10

15

BACKGROUND OF THE INVENTION

[0002] The invention generally relates to medical devices and methods. More specifically, the invention relates to energy based devices, systems and methods for treatment of patent foramen ovale.

[0003] Fetal blood circulation is much different than adult circulation. Because fetal blood is oxygenated by the placenta, rather than the fetal lungs, blood is generally shunted away from the lungs to the peripheral tissues through a number of vessels and foramens that remain patent (i.e., open) during fetal life and typically close shortly after birth. For example, fetal blood passes directly from the right atrium through the foramen ovale into the left atrium, and a portion of blood circulating through the pulmonary artery trunk passes through the ductus arteriosus to the aorta. This fetal circulation is shown in attached Figure 1.

[0004] At birth, as a newborn begins breathing, blood pressure in the left atrium rises above the pressure in the right atrium. In most newborns, a flap of tissue closes the foramen ovale and heals together. In approximately 20,000 babies born each year in the US, the flap of tissue is missing, and the hole remains open as an atrial septal defect (ASD). In a much more significant percentage of the population (estimates range from 5% to 20% of the entire population), the flap is present but does not heal together. This condition is known as a

patent foramen ovale (PFO). Whenever the pressure in the right atrium rises above that in the left atrium, blood pressure can push this patent channel open, allowing blood to flow from the right atrium to the left atrium.

[0005] Patent foramen ovale has long been considered a relatively benign condition, since it typically has little effect on the body's circulation. More recently, however, it has been found that a significant number of strokes may be caused at least in part by PFO. In some cases, stroke may occur because a PFO allows blood containing small thrombi to flow directly from the venous circulation to the arterial circulation and into the brain, rather than flowing to the lungs where the thrombi can become trapped and gradually dissolved. In other cases, thrombi might form in the patent channel of the PFO itself and become dislodged when the pressures cause blood to flow from the right atrium to the left atrium. It has been estimated that patients with PFOs who have already had cryptogenic strokes have a 4% risk per year of having another stroke.

[0006] Further research is currently being conducted into the link between PFO and stroke. At the present time, if someone with a PFO has two or more strokes, the healthcare system in the U.S. may reimburse a surgical or other interventional procedure to definitively close the PFO. It is likely, however, that a more prophylactic approach would be warranted to close PFOs to prevent the prospective occurrence of a stroke. The cost and potential side-effects and complications of such a procedure must be low, however, since the event rate due to PFOs is relatively low. In younger patients, for example, PFOs sometimes close by themselves over time without any adverse health effects.

[0007] Another highly prevalent and debilitating condition--chronic migraine headache--has also been linked with PFO. Although the exact link has not yet been explained, PFO closure has been shown to eliminate or significantly reduce migraine headaches in many patients. Again, prophylactic PFO closure to treat chronic migraine headaches might be warranted if a relatively non-invasive procedure were available.

[0008] Currently available interventional therapies for PFO are generally fairly invasive and/or have potential drawbacks. One strategy is simply to close a PFO during open heart surgery for another purpose, such as heart valve surgery. This can typically be achieved via a simple procedure such as placing a stitch or two across the PFO with vascular suture.

Performing open heart surgery purely to close an asymptomatic PFO or even a very small ASD, however, would be very hard to justify.

[0009] A number of interventional devices for closing PFOs percutaneously have also been proposed and developed. Most of these devices are the same as or similar to ASD closure devices. They are typically "clamshell" or "double umbrella" shaped devices which deploy an area of biocompatible metal mesh or fabric (ePTFE or Dacron, for example) on each side of the atrial septum, held together with a central axial element, to cover the PFO. This umbrella then heals into the atrial septum, with the healing response forming a uniform layer of tissue or "pannus" over the device. Such devices have been developed, for example, by companies such as Nitinol Medical Technologies, Inc. (Boston, MA) and AGA Medical, Inc. (White Bear Lake, MN). U.S. Patent No. 6,401,720 describes a method and apparatus for thoracoscopic intracardiac procedures which may be used for treatment of PFO.

[0010] Although available devices may work well in some cases, they also face a number of challenges. Relatively frequent causes of complications include, for example, improper deployment, device embolization into the circulation and device breakage. In some instances, a deployed device does not heal into the septal wall completely, leaving an exposed tissue which may itself be a nidus for thrombus formation. Furthermore, currently available devices are generally complex and expensive to manufacture, making their use for prophylactic treatment of PFO impractical. Additionally, currently available devices typically close a PFO by placing material on either side of the tunnel of the PFO, compressing and opening the tunnel acutely, until blood clots on the devices and causes flow to stop.

[0011] Research into methods and compositions for tissue welding has been underway for many years. Such developments are described, for example, by Kennedy et al. in "High-Burst Strength Feedback-Controlled Bipolar Vessel Sealing," Surg. Endosc. (1998) 12:876-878. Of particular interest are technologies developed by McNally et.al., (as shown in U.S. Patent No. 6,391,049) and Fusion Medical (as shown in U.S. Patents Nos. 5,156,613, 5,669,934, 5,824,015 and 5,931,165). These technologies all disclose energy delivery to tissue solders and patches to join tissue and form anastomoses between arteries, bowel, nerves, etc. Also of interest are a number of patents by inventor Sinofsky, relating to laser suturing of biological materials (e.g., U.S. Patent Nos. 5,725, 522, 5,569,239, 5,540,677 and 5,071,417). None of these disclosures, however, show methods or apparatus suitable for

positioning the tissues of the PFO for welding or for delivering the energy to a PFO to be welded.

[0012] Causing thermal trauma to a patent ovale has been described in two patent applications by Stambaugh et al. (PCT Publication Nos. WO 99/18870 and WO 99/18871).

5 The devices and methods described, however, cause trauma to PFO tissues in hopes that scar tissue will eventually form and thus close the PFO. Using such devices and methods, the PFO actually remains patent immediately after the procedure and only closes sometime later (if it closes at all). Therefore, a physician may not know whether the treatment has worked until long after the treatment procedure has been performed. Frequently, scar tissue may fail
10 to form or may form incompletely, resulting in a still patent PFO.

[0013] Therefore, it would be advantageous to have improved methods and apparatus for treating a PFO. Ideally, such methods and apparatus would help seal the PFO during, immediately after or soon after performing a treatment procedure. Also ideally, such devices and methods would leave no foreign material (or very little material) in a patient's heart.

15 Furthermore, such methods and apparatus would preferably be relatively simple to manufacture and use, thus rendering prophylactic treatment of PFO, such as for stroke prevention, a viable option. At least some of these objectives will be met by the present invention.

20 BRIEF SUMMARY OF THE INVENTION

[0014] The present invention generally provides methods, devices and systems for treating patent foramen ovale (PFO). As described in various embodiments, by using a catheter device to bring tissues adjacent the patent foramen ovale at least partially together and apply energy to the tissues, a PFO may be substantially closed acutely. By "substantially," it is
25 meant that a stable tissue bridge will be formed across the PFO, which will withstand physiologic pressures. A substantially closed PFO, however, may still have one or more small gaps or openings, which will in at least some cases close over time via the healing process. By "acutely," it is meant that the PFO is substantially closed when the closure procedure is completed. Thus, acute closure distinguishes embodiments described below
30 from prior techniques, which rely on delayed PFO closure via tissue healing and scarring. "Acutely," for purposes of this application, does not mean temporarily, since the various embodiments will typically provide for permanent (or at least long-term) PFO closure.

[0015] The phrase "tissues adjacent a PFO," or simply "PFO tissues," for the purposes of this application, means any tissues in, around or in the vicinity of a PFO which may be used or manipulated to help close the PFO. For example, tissues adjacent a PFO include septum primum tissue, septum secundum tissue, atrial septal tissue lateral to the septum primum or septum secundum, tissue within the tunnel of the PFO, tissue on the right atrial surface or the left atrial surface of the atrial septum and the like. By "application of energy," it is meant that energy may be transferred either to or from PFO tissues. For example, if cryogenic energy is applied, it could be said that heat energy is transferred out of the tissues. In various embodiments, any of a number of energy transfer devices and forms of energy may be used to provide such energy transfer. Types of energy used may include, for example, radiofrequency energy, cryogenic energy, laser energy, ultrasound energy, resistive heat energy, microwave energy and the like.

[0016] Application of energy to tissues to substantially close the PFO acutely may sometimes be referred to as "tissue welding." Preferably, tissue welding methods of the present invention will be performed without using tissue soldering material or other foreign material.

Examples of tissue solders or adhesives which may be used include, but are not limited to, autologous blood, albumin, collagen, fibrin, cyanoacrylates, mussel byssus adhesives, polymer hot melt adhesives and the like.

[0017] Embodiments described below provide for bringing tissues adjacent a PFO together (or "apposing" tissues). In various embodiments, tissues may be apposed before, during and/or after application or removal of energy to the tissues. Generally, energy application or removal will act to denature collagen in the PFO tissues. If the tissues are apposed before and/or during denaturation and/or while the collagen in the tissues is allowed to renature, the collagen in once-separated tissues binds together to bring the tissues together. Therefore, some embodiments include one or more devices for bringing (and possibly holding) tissues together before, during and/or after energy application or removal. By providing for substantial, acute closure of a PFO, devices, systems and methods may be advantageous for preventing stroke, treating migraine headaches and/or preventing or treating other medical conditions caused or exacerbated by PFO.

[017A] Various embodiments of the present invention provide a catheter device for treating a patent foramen ovale in a heart, the catheter device including: an elongate catheter body having a proximal end and a distal end; and at least one tissue apposition member at or near the catheter body distal end configured to bring tissues adjacent the patent foramen ovale at least partially together, the at least one tissue apposition member comprising a first tissue apposition member configured to contact septum secundum tissue adjacent the patent foramen ovale from the right atrium of the heart without penetrating the septum secundum tissue, and a second tissue apposition member configured to pierce into septum primum tissue; and wherein the first and second tissue apposition members comprise two electrodes of a bipolar radiofrequency (RF) device, and the first and second tissue apposition members are configured to grasp and apply energy to the septum secundum tissue and the septum primum tissue to substantially close the patent foramen ovale acutely.

[017B] Various embodiments of the present invention provide a system for treating a patent foramen ovale in a heart, the system comprising at least one guide member for guiding a catheter device to a position for treating the patent foramen ovale and said catheter device, wherein the catheter device comprises: an elongate catheter body having a proximal end and a distal end; and at least one tissue apposition member at or near the catheter body distal end configured to bring tissues adjacent the patent foramen ovale at least partially together, the at least one tissue apposition member comprising a first tissue apposition member configured to contact septum secundum tissue adjacent the patent foramen ovale from a right atrium of the heart without penetrating the septum secundum tissue, and a second tissue apposition member configured to pierce into a septum primum tissue; wherein the first and second tissue apposition members comprise two electrodes of a bipolar radiofrequency (RF) device, and the first and second tissue apposition members are configured to grasp and apply energy to the septum secundum tissue and the septum primum tissue to substantially close the patent foramen ovale acutely; wherein at least one of the tissue apposition members comprises an expandable member releasably disposed within the catheter body, wherein advancing the expandable member out the distal end of the catheter body allows the expandable member to expand within the patent foramen ovale; and wherein the expandable member comprises at least two members that expand apart to provide lateral force to the tissues adjacent the patent foramen ovale.

[0018] In one aspect of the present invention, a method of treating a PFO in a heart involves advancing a catheter device to a position in the heart for treating the PFO, bringing tissues adjacent the PFO at least partially together using the catheter device, and applying energy to the tissues with the catheter device to substantially close the PFO acutely. In some 5 embodiments the tissues are brought together before applying the energy. Optionally, the tissues may then be held together while applying the energy. In some embodiments, the tissues may be held together after the energy has been applied as well, to allow the tissues to cool, renature, close the PFO and/or the like. Optionally, the method may further involve actively cooling the tissues after the energy has been applied.

10 [0019] In some embodiments, after applying energy to the tissues, the catheter device may be moved to a different position relative to the PFO, tissue may be brought together again, and energy may be applied again. Some embodiments involve multiple repetitions of the moving, bringing together and energy application steps. In such embodiments, the PFO may be substantially closed by moving along the PFO with the catheter device, typically from one 15 side of the PFO to another, and bringing together tissues and applying energy multiple times. Such a method may be referred to as "spot welding" of PFO tissues. In some embodiments, one or more biasing members on the catheter may be used to bias the catheter toward one side of the PFO. For example, the shape of a catheter body, an expandable member, a biasing wire or the like may help urge the catheter to one side. Typically, the catheter may then be 20 moved across the PFO, bringing tissues together and applying energy at multiple positions along the way. In one embodiment, for example, tissue apposition members (which may also be configured to apply energy to the tissues) squeeze tissue between them. As they do so, they may also squeeze a shaped catheter body between the tissues, and the cross-sectional shape of the catheter body may cause it to be urged to a new position as the tissue is squeezed 25 down upon it. For example, the catheter body may have a triangular, oval, diamond, or other shape. After energy is applied at the first position, the tissue apposition members are moved to the second position and again squeeze down on tissue and the catheter body, thus urging the catheter body to a third position and so on.

[0020] A number of other suitable techniques are also contemplated for moving across the 30 PFO and "spot welding" the tissues. In another embodiment, for example, a large stationary electrode is positioned either in the right or left atrium and a smaller mobile electrode is

moved along the PFO in the other atrium to create spot welds. In other embodiments, one or more electrodes may be rotated around the circumference of the PFO.

[0021] Advancing the catheter device to a position in the heart for treating the PFO may be accomplished by any suitable technique. In some embodiments, for example, a first distal
5 portion of the catheter is advanced to a location in the right atrium and that first distal portion is used for bringing tissues together. In some embodiments, a second distal portion may be advanced into or through the PFO, and the first and second distal portions are then used to appose the tissues. In some embodiments, the second portion extends through the PFO and into the left atrium, so that the first portion contacts tissue from the right atrial side and the
10 second portion contacts tissue from the left atrial side. In various embodiments, either one or both of the portions may then be manipulated to bring the tissues together between them. For example, one or both portions may be moved axially toward one another. In some embodiments, one portion is moved axially toward the other portion, the latter portion being held relatively stationary to act as a "backstop" or surface against which to bring the tissues
15 together. Many such backstop devices are described in patent application numbers 60/458,854, 60/478,035, and 60/490082.

Optionally, either or both of the portions may also be used to apply energy to the tissues.

[0022] Bringing the tissues at least partially together may be accomplished by any of a number of suitable methods. For example, as just mentioned, first and/or second distal
20 portions of the catheter device may be moved toward one another to trap, clamp, grasp, grip or otherwise appose tissues between the two members. In another embodiment, tissues may be brought together by expanding one or more expandable members. For example, one expandable member may be expanded in either the right or left atrium to push against tissue and thus bring them together. In another embodiment, one expandable member may be
25 expanded in the right atrium and a second expanded in the left atrium, with the expansion causing the tissues to be squeezed together between the two members. A similar result may be achieved by using one expandable member and a "backstop" member, as described above. Some embodiments further include moving one expandable member toward the other to further bring the tissues together. For example, an expandable member may be slid axially
30 toward another expandable member along the catheter device. Again, any suitable technique may be used.

[0023] In alternative embodiments, bringing the tissues together may involve deploying an expanding member within the PFO. The expanding member, such as two-pronged "fish-mouthing" member, is typically disposed in a sheath while advanced into the PFO. The sheath is then retracted to allow the prongs to expand away from each other. Such expanding, "fishmouth," two-pronged members may be constructed of shape memory materials, spring-loaded materials or the like. By spreading PFO tissues laterally between two prongs, the tissues come together in the area between the prongs. In some embodiments, one or more expandable members may be coupled with the prong(s) or the catheter device to further assist in bringing the tissues together. Optionally, the method may also include contacting a left atrial surface of at least one of a septum primum and a septum secundum with a distal portion of the expanding member and retracting the expanding member to bring the tissues adjacent the PFO together. For example, the distal portion may contact the septum primum and pull it toward the right side of the heart, into contact with the septum secundum. At some point after the expanding member has been used to appose the tissues adjacent the PFO, it may be advantageous to retract the expanding member to a position within the catheter device. For example, the expanding member may be retracted in some embodiments before removing the catheter device.

[0024] In other embodiments, the first distal portion and/or the second distal portion of the catheter device may be advanced into tissues adjacent the PFO. In other words, one or more portions of the catheter device may be caused to pierce into PFO adjacent tissues. Such an embodiment, for example, may involve use of a jaw-like device, with the first and second tissue apposition members comprising opposing jaws. In one embodiment, for example, the first distal portion is advanced into septum secundum tissue. Optionally, the second distal portion may be advanced into septum primum tissue. The first and second tissue apposition members may then be moved together to bring tissues together. In yet another embodiment, a clamp-like device may be used, either with or without piercing tissues. With clamping, one portion of the clamp may contact tissue from the right atrium, and the other may contact tissue from the left atrium. Again, any of a number of other suitable techniques may be used, some of which are described more fully in U.S. Patent Application Nos. 60/458,854, 60/478,035, 60/490082, 10/665974, and 10/679245.

[0025] In some embodiments the catheter device may be advanced over a guidewire. The guidewire typically extends through the PFO and may include an expanding portion along its length for expanding within the PFO. Optionally, the guidewire may extend into the left atrium, and the method may optionally include contacting a left atrial surface of at least one of a septum primum and a septum secundum with a distal portion of the guidewire and retracting the guidewire to bring the tissues adjacent the PFO together.

[0026] Any suitable type of energy may be applied to the PFO tissues to provide acute PFO closure. In some embodiments, for example, monopolar or bipolar radiofrequency energy is applied, while in alternative embodiments cryogenic, resistive heat, ultrasound, microwave, or laser energy, heat energy in the form of heated fluid such as saline, or the like may be applied. Energy may be applied by energizing a single conductive member of the catheter device or multiple conductive members, in various embodiments. Generally, any suitable devices for energy delivery are contemplated. In one embodiment, applying energy to the tissues involves applying energy to a conductive fluid and releasing the conductive fluid from the catheter device to contact the tissues. For example, a conductive fluid such as saline may be introduced into one or more expandable members of the catheter device, energy such as radio frequency energy may be applied to the fluid, and the fluid may then be released from the expandable member(s) through at least one, and preferably many, small apertures on the expandable member. The energized conductive fluid then contacts the tissues to close the PFO.

[0027] Some embodiments of the method may further involve monitoring an amount of energy applied to the tissues. For example, monitoring the energy may involve monitoring a temperature of the tissues, an impedance of the tissues and/or the like. Such a method may further involve determining when a sufficient amount of energy has been applied to the tissues to acutely close the PFO. Optionally, the method may also include discontinuing the application of energy when the sufficient amount of energy has been applied.

[0028] Any of the above methods may also involve directly visualizing the PFO and the adjacent tissues using at least one visualization device coupled with the catheter device. Such a visualization device may include a fiber optic device, an ultrasound device or any other suitable visualization device.

[0029] In another aspect of the present invention, a method of treating a patent foramen ovale in a heart includes: advancing a catheter device to a position in the heart for treating the patent foramen ovale; bringing tissues adjacent the patent foramen ovale at least partially together using the catheter device; applying energy to the tissues with the catheter device while holding the tissues at least partially together; and holding the tissues at least partially together for a sufficient time after applying the energy to substantially close the patent foramen ovale. Such a method may include any of the features of the embodiments described above.

[0030] In yet another aspect of the invention, a catheter device for treating a patent foramen ovale in a heart includes an elongate catheter body having a proximal end and a distal end, at least one tissue apposition member at or near the catheter body distal end for bringing tissues adjacent the patent foramen ovale at least partially together, and at least one energy transmission member at or near the distal end for applying energy to the tissues to substantially close the patent foramen ovale acutely. In some embodiments, the at least one tissue apposition member comprises a first tissue apposition member for contacting tissue from the right atrium of the heart. Optionally, a second tissue apposition member may be included for contacting tissue either from the right atrium or the left atrium, in various embodiments. For example, in one embodiment the first and second members may comprise a set of opposable jaws that may be used from within the right atrium to bring the tissues together, optionally advancing through one or of the PFO-adjacent tissues. In other embodiments, the second member may be advanced through the PFO to contact the tissue from the left atrium. Any number of different tissue apposition members may be included.

[0031] As described above, for example, one or both of first and second tissue apposition members may comprise expandable members, and either (or both) may be axially slidable toward the other to bring tissue together between them. In other embodiments, one expandable member and one shaped deployable "backstop" member may be used. The deployable member, for example, may comprise a shape-memory device which is advanced into the left atrium and deployed to contact tissue. An expandable balloon may be expanded and possibly moved axially along the catheter to bring the tissue together between it and the deployable backstop. Any one or more of such expandable members may also include at least one small aperture for allowing conductive fluid to escape from expandable member to

contact the tissues. Some embodiments include multiple small apertures, and some include two expandable members with apertures.

[0032] In other embodiments, first and second tissue apposition members are configured as arms of a clamp, with one arm disposed in the right atrium and the other in the left atrium, for clamping tissues together. Still other embodiments may include one set of opposable jaws and one hook or clamp member to bring the tissue toward the clamp. In other embodiments, the first and second members are configured as a clip, "bobby pin," or the like, wherein the relative shapes of the first and second apposition members urge the tissues together. For example, in one embodiment one of the members may be shaped as a hook or similarly curved member for hooking over the PFO to contact the tissues from the left atrium, while the other member may be relatively straight to contact the tissues from the right atrium. Tissues may thus be grasped together between the two members, bringing them together, not unlike an object placed between the tongs of a bobby pin or within the curves of a paper clip.

[0033] Some embodiments of the apparatus further include a guide member for advancing through the PFO, with the catheter device being slidably disposed over the guide member. The guide member may include, for example a guide catheter and at least one expandable member disposed within the guide catheter, wherein the guide catheter is retractable to expose the expandable member to allow it to expand within the PFO. The expandable member, in turn, may have any suitable configuration, but in some embodiments it includes at least two members that expand apart to provide lateral force to the tissues adjacent the PFO, such as a "fishmouth" or two-prong expandable member. When exposed, the expanding member may also provide dilatory force to the tissues adjacent the PFO. To provide expandability, the expandable member may be made of shape memory material, may be spring loaded, and/or the like.

[0034] In alternative embodiments, the guide member may comprise a guidewire having an expandable portion along its length. For example, the expandable portion may be a divided portion, the divided portion comprising expandable shape memory material. Optionally, the guide member may include at least one tip for contacting a left atrial surface of the tissues adjacent the PFO. Such a tip may be conformable to the left atrial surface. The guide member may be retractable to engage the at least one tip with the left atrial surface. In any of the above embodiments, one or more guide members, or component parts of a guide member,

may act as one or more energy transmission members. In some embodiments, for example, an expanding member may act as a monopolar or bipolar radiofrequency electrode.

[0035] The at least one energy transmission member of the catheter device may comprise any suitable energy transmission device or combination of devices. For example, the
5 transmission member may transmit radiofrequency energy, cryogenic energy, resistive heat energy, ultrasound energy, microwave energy, laser energy or any other form of energy for treating PFO tissues. In preferred embodiments, the energy transmission member comprises a monopolar or two bipolar radiofrequency transmission members. Such a transmission member, for example, may be curved to approximate the curvature of the PFO. In other
10 embodiments, straight transmission members, mesh or braided transmission members, multiple pin-point transmission members or the like may be used.

[0036] In some embodiments, one or more energy transmission members are coupled with one or more tissue apposition members. In some embodiments, for example, one or more energy transmission members simply act as tissue apposition members. In some
15 embodiments, energy transmission member is movable along at least part of a circumference of the at least one tissue apposition member. In alternative embodiments, the energy transmission member comprises a guide member for advancing through the PFO, with the catheter device being slidably disposed over the guide member. Again, the guide member typically includes at least one expandable portion for expanding within the PFO to at least
20 partially bring together the tissues adjacent the PFO, and in some embodiments the expandable member acts as the energy transmission member(s). In still other embodiments, energy transmission members may be coupled with both the tissue apposition member and the guide member/expandable member.

[0037] As described above, in one embodiment the at least one energy transmission
25 member include one or more energy transmission member disposed within an expandable member for applying energy to a conductive fluid. The energy transmission member further includes one or more conductive fluids which are introduced into the expandable member(s) and then allowed to escape from the expandable members, typically via multiple apertures. In various embodiments, one, two or more expandable members with apertures, conductive
30 fluid and an energy transmission member may be included. In one embodiment, radio frequency energy is transmitted to saline solution as the conductive fluid, but in alternative embodiments other forms of energy and/or conductive fluid(s) may be used.

[0038] Some embodiments of the catheter device may further include at least one sensor coupled with the catheter device for sensing an amount of energy delivered to the tissues by the at least one energy transmission member. Sensors, for example, may be infrared sensors, thermistors, thermocouples or the like, though any sensors may be used. Optionally, a
5 microprocessor may be coupled with the at least one sensor for processing sensed data to determine when the amount of delivered energy has reached a desired amount of energy.

[0039] In another aspect of the invention, a system for treating a patent foramen ovale in a heart includes a catheter device and at least one guide member for guiding the catheter device to a position for treating the patent foramen ovale. The catheter device includes an elongate
10 catheter body having a proximal end and a distal end, at least one tissue apposition member at or near the catheter body distal end for bringing tissues adjacent the patent foramen ovale at least partially together, and at least one energy transmission member at or near the distal end for applying energy to the tissues to substantially close the patent foramen ovale. The catheter device may include any of the features or variations described above.

15 [0040] These and other embodiments are described in further detail in the following description related to the appended drawing figures.

BRIEF DESCRIPTION OF THE DRAWING FIGURES

[0041] FIG. 1 is a diagram of the fetal circulation;

20 [0042] FIG. 2 is a diagram of a catheter apparatus according to an embodiment of the present invention, the catheter passing through the inferior vena cava and right atrium and through the PFO;

[0043] FIG. 3 is a perspective view of a distal portion of a catheter apparatus having two expandable members according to an embodiment of the present invention;

25 [0044] FIG. 4 is a perspective view of a distal portion of a catheter apparatus having two expandable members according to another embodiment of the present invention;

[0045] FIG. 5 is a perspective view of a distal portion of a catheter apparatus having one expandable member according to another embodiment of the present invention;

[0046] FIG. 6 is a perspective view of a distal portion of a catheter apparatus having one expandable member and a shape-memory member according to another embodiment of the present invention;

5 [0047] FIG. 7 is a perspective view of a distal portion of a catheter apparatus having two expandable members coupled with two prongs according to another embodiment of the present invention;

[0048] FIG. 8 is a perspective view of a distal portion of a catheter apparatus having one expandable member and two prongs according to another embodiment of the present invention;

10 [0049] FIG. 9 is a cross-sectional view of a distal portion of a catheter apparatus having two tissue apposition members and a shaped catheter body according to another embodiment of the present invention;

[0050] FIG. 10 is a perspective view of a distal portion of a catheter apparatus having two tissue apposition members and a shaped catheter body according to another embodiment of
15 the present invention;

[0051] FIGS. 11A-11C are perspective views of a distal portion of a catheter apparatus, demonstrating a method for bringing tissues together according to another embodiment of the present invention;

[0052] FIGS. 12A and 12B are perspective views of a distal portion of a catheter apparatus
20 having opposable jaws according to another embodiment of the present invention;

[0053] FIGS. 13A and 13B are perspective views of a distal portion of a catheter apparatus having opposable jaws according to another embodiment of the present invention;

[0054] FIG. 14 is a perspective view of a distal portion of a catheter apparatus having a two-prong tissue apposition member with vacuum according to another embodiment of the
25 present invention;

[0055] FIGS. 15A and 15B are perspective views of a distal portion of a catheter apparatus having opposable jaws and a curved member according to another embodiment of the present invention;

[0056] FIGS. 16A and 16B are perspective views of a distal portion of a catheter apparatus having magnetic tissue apposition members according to another embodiment of the present invention;

[0057] FIG. 17 is a perspective view of a distal portion of a catheter apparatus having clamping tissue apposition members according to another embodiment of the present invention;

[0058] FIG. 18 is a right atrial view of a PFO with a stationary energy transmission member in the right atrium and multiple tissue welds according to another embodiment of the present invention;

[0059] FIG. 19 is a perspective view of a distal portion of a catheter apparatus having two expandable members and a guidewire extending through the right and left atria of the heart according to another embodiment of the present invention; and

[0060] FIGS. 20A-20C are perspective views of a distal portion of a catheter apparatus having two separate tissue apposition members according to another embodiment of the present invention.

DETAILED DESCRIPTION OF THE INVENTION

[0061] Devices and methods of the present invention generally provide for patent foramen ovale (PFO) treatment through application of energy. Methods involve advancing a catheter device to a position in the heart for treating the PFO, bringing tissues at least partially together using the catheter, and applying energy to tissues adjacent a PFO to substantially close the PFO acutely. Devices of the invention generally include a catheter device having a proximal end and a distal end, at least one tissue apposition member, and at least one energy transmission member adjacent the distal end.

[0062] Figure 1 is a diagram of the fetal circulation. The foramen ovale is shown, with an arrow demonstrating that blood passes from the right atrium to the left atrium in the fetus. After birth, if the foramen ovale fails to close (thus becoming a PFO), blood may travel from the right atrium to the left atrium or vice versa, causing increased risk of stroke, migraine and possibly other adverse health conditions, as discussed above.

[0063] With reference to Figure 2, one embodiment of a catheter device 10 for treating PFO suitably includes a catheter body 12 and one or more tissue apposition members 14. Catheter device 10 may be advanced through the vasculature of a patient to a position in the heart for treating a PFO. For example, as shown catheter device 10 has been advanced
5 through the inferior vena cava into the right atrium of the heart. In alternative embodiments, a catheter device may be advanced through the aorta to the left ventricle and then into the left atrium of the heart to treat the PFO. In some embodiments, two separate portions of a catheter apparatus may be advanced to the right atrium and left atrium, and in yet another embodiment, a guidewire or other component of a catheter apparatus may extend from
10 outside the patient, through the vasculature to the right atrium, through the PFO to the left atrium, and out the aorta to the vasculature to exit the patient from a second site. Various embodiments may thus make use of any suitable access technique for disposing a catheter device in a location for treating a PFO.

[0064] Catheter body 12 typically comprises an elongate, flexible body having at least one
15 lumen. Catheter body 12 may be manufactured from any suitable material or combination of materials known in the catheter arts or hereafter discovered; such as PTFE, other polymers or the like. Catheter body 12 may also having any suitable size, profile, diameter, shape and the like. Optionally, catheter body 12 may be slidably disposed over a guide member (not shown), such as a guide catheter, guidewire, or the like. In some embodiments, such a guide
20 member may include one or more expanding members or other similar devices for deploying within the PFO to help appose the adjacent tissues. For further description of such expandable guide members, reference may be made to U.S. Patent Application No. 10/679245.

[0065] Tissue apposition members 14 generally may include any one, two or more devices
25 for helping bring tissues adjacent the PFO together. As shown in Fig. 2, one member 14 may be disposed in the right atrium to contact tissue from the right atrial side, such as septum secundum tissue, while the other member 14 may be advanced through the PFO to contact tissue from the left atrium. In some embodiments, tissue apposition members 14 may be pre-shaped and manufactured from shape-memory material, spring stainless steel or the like, such
30 that when they are released from catheter body 12, they take on a shape that allows them to bring the tissues together.

[0066] Catheter device 10 also includes at least one energy transmission member. In the embodiment shown, either one or both of tissue apposition members 14 may also act as energy transmission members. In various embodiments, energy transmission members may be capable of bringing the tissues together, energy transmission members may be coupled with tissue apposition members, or energy transmission members may be separate from and not coupled with tissue apposition members. Also in various embodiments, one energy transmission member may be used, such as to provide monopolar radiofrequency energy (RF), two transmission members may be used, such as to provide bipolar RF energy, or more than two transmission members may be used.

10 [0067] Referring now to Figure 3, another embodiment of a catheter device 20 for PFO treatment suitably includes a catheter body 22, a first expandable member 27 having a first energy transmission member 23, and a second expandable member 28 having a second energy transmission member 25, with each expandable member 27, 28 including multiple apertures 24 for allowing passage of conductive fluid 26. Expandable members 27, 28 may be positioned for treatment, such as in the right atrium (first member 27) and the left atrium (second member 28) and then expanded to bring together tissues of the septum secundum SS, septum primum SP and/or other PFO-adjacent tissue. In some embodiments, one or both of expandable members 27, 28 may also be moved axially along catheter body 22, such as by sliding, so as to bring the tissues together between the two expandable members 27, 28. For example, second expandable member 28 may be disposed on a separate catheter body disposed over or within catheter body 22 to allow second member 28 to axially slide back and forth along catheter body 22.

[0068] Expandable members 27, 28 may comprise any suitable material or combination of materials now known or developed in the future. Expandable balloon members for use on catheters are well known, and any suitable variation may be used in various embodiments of the invention. Expandable members 27, 28 may be made of conformable elastomeric materials, polymers or the like and may have any suitable shape upon expansion.

[0069] Energy may be applied to the tissues by introducing one or more conductive fluids 26, such as saline solution or the like, into expandable member 27, 28, applying energy (such as RF energy) to conductive fluids 26 via energy transmission members 25, 27, and then allowing fluid(s) 26 to pass from apertures 24 to contact the tissues. Thus, the fluid 26 may

provide the needed energy to the tissues to cause closure of the PFO. After transmitting the energy to the nearby PFO tissues, conductive fluid 26 harmlessly dissipates in the body.

[0070] In various embodiments, energy transmission members may comprise any of a number of devices and may transmit any suitable type of energy for closing a PFO. Some types of energy which may be used, for example, include radiofrequency, cryogenic, resistive heat, ultrasound, microwave and laser energy. Radiofrequency energy transmission members may be either monopolar or bipolar, with monopolar catheter devices also including a grounding member. Energy transmission members may also have any suitable configuration, many of which are described below in reference to specific embodiments. In some embodiments, energy transmission members are fixedly coupled with tissue apposition member, while in other embodiments energy transmission members are movable within tissue apposition member, for example to move about the circumference of the PFO to weld PFO tissues at multiple locations. In some embodiments, energy delivery is achieved by circulating cooled or heated fluids within expandable members 27, 28, without allowing such fluids to pass out of expandable members 27 & 28. In these embodiments, apertures 24 are eliminated from the design.

[0071] Energy transmission members 23, 25 provide sufficient energy transfer, for a sufficient time, to weld the tissues. The time span of energy transmission may be, for example, from about 0.5 seconds to about 15 minutes, and more preferably from about 30 seconds to about 5 minutes. Energy transmission, in some embodiments, may be from about 0.5 Watts to about 100 Watts, and more preferably from about 5 Watts to about 50 Watts. In various embodiments, any other suitable energy and timing combination may alternatively be used. In one experimental example, a PFO in a section of pig heart tissue used ex-vivo in a flowing saline test fixture was closed by applying suction to appose the PFO tissues and applying RF energy at approximately 25 watts for 7 minutes. RF energy application was then discontinued, but tissue apposition was continued for an additional 1 minute to hold tissues together while cooling, thus allowing collagen in the tissues to reorganize and bind together to form a stable tissue bridge. In alternative embodiments, other energy amounts, energy application times, tissue apposition times and the like may be used.

[0072] Although any suitable type of energy may be transmitted by energy transmission members in various embodiments, some embodiments make use of monopolar or bipolar radiofrequency (RF) energy. Devices may use monopolar radiofrequency energy, for

example, wherein energy is applied simultaneously to all conductive elements, completing the circuit through an external ground pad affixed to the skin of the patient. Alternatively, bipolar energy may be applied to all conductive elements simultaneously, and the circuit completed through a ground element incorporated elsewhere on the catheter device. Further
5 embodiments may include applying bipolar energy between two or more energy transmission members, which are electrically isolated from one another within catheter device.

[0073] Control systems coupled with energy transmission members or tissue apposition members, or otherwise disposed within a catheter device, may sense an amount of energy delivered to PFO tissues and, optionally, may automatically stop energy delivery upon
10 detecting a change in condition of energy delivery, for instance an increase in electrical resistance or impedance in PFO tissues or in the catheter device, an increased energy draw from the catheter device, and/or the like. In some embodiments, energy delivery may be automatically stopped when an amount of delivered energy reaches a desired level, such as an amount of energy sufficient to substantially close the PFO. The amount of delivered energy
15 may be monitored by any suitable method, such as monitoring temperature or impedance in PFO tissues or the like. In some embodiments, one or more sensors coupled with tissue apposition members, energy transmission members, or any other part of a catheter device may be used for monitoring such indicia. Examples of sensor devices include but are not limited to infrared sensing devices, thermistors and thermocouples. Optionally, a control
20 system may also include a microprocessor coupled with the sensors to determine when a desired amount of energy has been delivered and/or to automatically stop energy transmission. In alternative embodiments, a microprocessor may be attached to a catheter device which can sense, monitor and control energy delivery, thus not requiring separate sensors.

25 [0074] Figure 4 shows a slightly different embodiment of a catheter device 30 having a catheter body 32, a first expandable member 37 and a second expandable member 38 having an energy transmission member 35 and multiple apertures 34 for allowing passage of a conductive fluid 36. In this embodiment, first expandable member 37 may be used as a tissue apposition member without providing additional energy transmission.

30 [0075] Referring to Figure 5, an alternative embodiment of a catheter device 40 for treating PFO includes a catheter body 42, an expandable member 48 having apertures for allowing passage of fluid 46, and an energy transmission member 45. In this embodiment, expanding

expandable member 48 may be sufficient to bring tissues together, or proximally directed force may be applied to expandable member 48, such as by pulling back on catheter body 42, to bring the tissues together.

5 [0076] Referring now to Figure 6, one embodiment of a catheter device 50 includes a catheter body 52, an expandable member 57 having an energy transmission member 53 disposed within it and apertures 54 on its surface for allowing passage of conductive fluid 56, and a shaped distal portion 59. Shaped distal portion 59 resides in the left atrium and acts as a surface or "backstop," such that tissue may be brought together between shaped distal portion 59 and expandable member 57. In the embodiment shown, shaped portion 59 is a
10 helical coil, which may be made of shape memory material, spring stainless steel or the like, so that it has a relatively straight configuration while disposed within catheter body 52, but assumes the coiled configuration when released. In other embodiments, other backstop devices may be used, such as those described more fully in U.S. Patent Application No. 60/478,035.

15 [0077] Figure 7 shows another embodiment of a catheter device 60, which includes a catheter body 62, a two-pronged tissue apposition member 64, and two expandable members 66 coupled to the two prongs 64 for providing further tissue apposition. Tissue apposition member 64, the prongs of which may comprise nitinol, some other shape memory material, or the like, is typically released from catheter body 62 within a PFO to allow the prongs 64 to
20 expand apart. The tissue between the prongs is thus brought together, in essence flattening or "fish-mouthing." For further tissue apposition expandable members 66 may be expanded, and optionally, proximal force may be applied, such as by pulling back on catheter body 62, to urge the tissues together with expandable members 66. Prongs 64 then act as energy transmission members for applying energy to the tissues. Typically, prongs 64 are bipolar RF
25 energy transmission members, but alternative embodiments are also contemplated.

[0078] In an alternative embodiment, and referring now to Figure 8, a catheter device 70 may include a catheter body 72, a two-pronged tissue apposition member 74, and a separate expandable member 76 for enhancing tissue apposition. Again, tissue apposition members 74 may also act as energy transmission members. Additionally or alternatively, apertures may
30 be provided in expandable member 76 for introducing conductive fluid as a portion of the energy delivery system.

[0079] With reference now to Figure 9, in another embodiment a catheter device 80 suitable includes a catheter body 86, a first tissue apposition member 82 and a second tissue apposition member 84. As mentioned previously, one or both of tissue apposition members 82, 84 may be coupled with or may act as energy transmission members. In this
5 embodiment, first tissue apposition member 82 is configured to contact tissue from the right atrium, such as septum secundum tissue SS, while second apposition member 84 is configured to contact tissue from the left atrium, such as septum primum tissue SP. In contacting and bringing these tissues together (hollow-tipped arrows), tissue apposition members 82, 84 also bring the tissues together (or squeeze the tissues) against catheter body
10 86. When force is applied against catheter body 86, it is urged to one side (solid-tipped arrows), due to its cross-sectional shape. In the embodiment shown, catheter body 86 has a triangular cross-section, though in alternative embodiments it may have other shapes, such as oval, ellipsoid, diamond-shaped, or the like. When catheter body 86 is urged aside, tissue apposition/energy transmission members 82, 84 are used to apply energy to tissue in a first
15 location. Apposition members 82, 84 may then be moved to the side, toward catheter body 86, to bring adjacent tissues together, thus urging catheter body 86 further along the PFO. Energy may then be applied again to the tissue in the second location. Using such a technique, it may be possible to move catheter device 80 across a PFO from one side to another, applying energy and closing the PFO as device 80 is moved. In other words,
20 catheter devices "walks" along the PFO, spot tissue welding as it goes.

[0080] Figure 10 shows one embodiment of a catheter device 90 which may be used in a method similar to the one just described. Device 90 includes a catheter body 92, a first tissue apposition member 94, and a second tissue apposition member 96, and is shown disposed over a guidewire 98. In this embodiment, tissue apposition members 94, 96 also act as
25 energy transmission members. First tissue apposition member 94 is a spring-loaded jaw, and second tissue apposition member 96 is a shape-memory energy transmission member, such as an electrode. As described above, when tissue apposition members 94, 96 bring tissue adjacent the PFO together, they bring the tissue together against catheter body 92, thus squeezing catheter body 92 aside. After applying energy to the tissues, tissue apposition
30 members 94, 96 may then be moved toward catheter body 92 again and used to bring tissue together again, thus squeezing catheter body 92 aside again. To enhance such a technique, catheter body 92 may include one or more slick or slippery surfaces, to allow it to more easily slide to the side. Catheter body 92 may also include a coating of a tissue welding substance,

solder or the like, such as albumin, which partially rubs off each time catheter body is squeezed aside, thus enhancing application of energy to the tissues to close the PFO.

Catheter body 92 may further include one or more apertures for introducing a fluid at the location of energy application, to act as a welding fluid or to otherwise enhance tissue

5 welding.

[0081] In the embodiments described in Figures 9 and 10, as well as in other embodiments, a catheter device may also include a biasing member for biasing the catheter device toward one side of a PFO to start a PFO closure procedure. For example, an expandable member may be coupled with a catheter body, typically on one side of the body, such that when the

10 catheter device is positioned in the PFO and the expandable member is expanded, the catheter device is urged to one side of the PFO. Tissue may then be brought together and welded at that side and the expandable member may be gradually deflated to allow the catheter device to move toward the other side of the PFO, bringing tissue together and applying energy as it goes. A similar result may be achieved with a biasing wire, a catheter body having a biasing

15 shape, or the like.

[0082] Referring now to Figures 11A-11C, in another embodiment a catheter device 100 for treating a PFO includes a catheter body 106, a first tissue apposition member 104 and a second tissue apposition member 102. Tissue apposition members 102, 104 comprise shape memory material energy transmission members made of nitinol or any other suitable shape

20 memory material(s). To deploy tissue apposition members 102, 104, catheter body 106 is first advanced through the PFO, as shown in Fig. 11A. Catheter body 106 is then withdraw/retracted and second tissue apposition member 102 is advanced (solid-tipped arrows), so that second tissue apposition member 102 is released from the distal end of catheter body 106. As shown in Fig. 11B, catheter body 106 may then be advanced again to

25 push against a surface of second tissue apposition member 102, thus opening apposition member (solid-tipped arrows) to fit over PFO-adjacent tissue such as the septum primum. This technique is analogous to expanding the tines of a bobby pin. As shown in Fig. 11C, after second tissue apposition member 102 is placed in contact with the septum primum, catheter body 106 may be retracted again and first tissue apposition member 104 may be

30 advanced to expose first member 104. Tissues are then brought together between the two apposition members 102, 104 and the members 102, 104 are used to apply energy to the tissues to close the PFO.

[0083] Figs. 12A and 12B show another embodiment of a catheter device 110 for treating PFO, including a catheter body and a pair of opposable jaws 114. Jaws 114 may be used to grasp tissue adjacent the PFO, such as septum secundum SS and septum primum SP tissues, to bring them together for energy application and tissue welding. Jaws 114 may also
5 comprises energy transmission members, such as two electrodes of a bipolar RF device, one electrode and one energy return member of a monopolar RF device, or the like. In some embodiments, one or both jaws 114 may be advanced through (or in other words pierce into) PFO tissues. Here, as designated by the dotted lines, one jaw is advanced into septum primum SP tissue. Fig. 12A shows jaws 114 expanded, and Fig. 11B shows jaws 114 drawn
10 together to draw the tissues together.

[0084] Referring to Figs. 13A and 13B, catheter device 110 is shown with both jaws 114 piercing tissue adjacent the PFO. Again, jaws 114 are expanded in Fig. 13A and drawn together in 13B to bring the tissues into apposition.

[0085] Referring now to Figure 14, in one embodiment a catheter device 120 for treating
15 PFO suitably include a catheter body 122 and a two-pronged, "fish mouth" tissue apposition member 124 having multiple vacuum apertures 126 for applying a vacuum force to enhance tissue apposition. As already described, tissue apposition prongs 124 may be deployed inside the PFO to bring tissues together, and vacuum apertures 126 may then be used to further appose the tissues. Energy may then be applied via tissue apposition prongs 124, which may
20 comprise bipolar RF energy transmission members in one embodiment.

[0086] With reference to Figures 15A and 15B, another embodiment of a catheter device 130 suitably includes a catheter body 132, a grasping tissue apposition member 134, and a shape memory tissue apposition member 136. These tissue apposition members 134, 136 may be used to contact tissue from right and left atrial sides of the PFO, as in Fig. 15A, and
25 then used to bring the tissues together, as in Fig. 15B. Either or both tissue apposition members 134, 136 may also act as energy transmission members.

[0087] In Figures 16A and 16B, a catheter device 140 includes a catheter body 142, a positively charged magnet 144 and a negatively charged magnet 146. The magnets 144, 146 act as both tissue apposition members and energy transmission member and bring tissue
30 together between them due to their opposite polarities, as shown in Fig. 16B.

[0088] In another embodiment, as shown in Figure 17 in a perspective from inside the right atrium, a tissue apposition member 150 of a catheter device for treating PFO may comprise a clamp, including a first clamp arm 152 for positioning in the right atrium and a second clamp arm 154 for positioning in the left atrium. The arms 152, 154 are then brought together to
5 bring the tissues together.

[0089] In Figure 18, again from a perspective from inside the right atrium, only an electrode 162 is shown. In one embodiment of the device, a relatively large electrode 162 may be positioned in the right atrium and maintained in approximately the same position throughout a procedure. A smaller electrode may then be disposed in the left atrium and
10 moved along the tissues of the PFO to create spot tissue welds 164 to close the PFO. Pressure and bipolar RF energy is directed between the smaller electrode and the larger electrode 162, to bring the tissue together and apply energy to close the PFO.

[0090] Referring now to Figure 19, in yet another embodiment, a catheter system 170 for treating PFO may include a first catheter body 172 having a first expandable member 176, a
15 second catheter body 174 having a second expandable member 178 and a guidewire 179. In one embodiment, guidewire extends from an entry point on the patient, such as a femoral vein, through the inferior vena cava IVC, right atrium RA, PFO and left atrium LA, and then through the left ventricle, aorta, and eventually out a femoral artery. Catheter bodies 172, 174 may be advanced to locations in the right and left atria respectively along this guidewire.
20 In an alternative embodiment, two guidewires may be used, and they may be coupled within the PFO or elsewhere within the heart.

[0091] In another embodiment, as shown in Figures 20A-20C, a catheter device 180 includes a catheter body 182, a left atrial tissue apposition member 184 and a separate right atrial tissue apposition member 186. Fig. 20A shows just catheter body 182 and left atrial
25 member 184 from a right atrial view, with left atrial member 184 hooking over the PFO into the left atrium. Fig. 20B is a close-up view from the perspective of the distal end of left atrial member 184 hooking into the left atrium. Fig. 20C shows both left atrial member 184 and right atrial member 186 in place for apposing PFO tissues. In one embodiment, left atrial member 184 may be rotated (curved arrow) to move the hooked portion along the left atrial
30 surface of the PFO to apply energy at multiple locations.

[0092] Although the foregoing description is complete and accurate, it describes only exemplary embodiments of the invention. Various changes, additions, deletions and the like may be made to one or more embodiments of the invention without departing from the scope of the invention. Additionally, different elements of the invention could be combined to
5 achieve any of the effects described above. Thus, the description above is provided for exemplary purposes only and should not be interpreted to limit the scope of the invention as set forth in the following claims.

WHAT IS CLAIMED IS:

1. A catheter device for treating a patent foramen ovale in a heart, the catheter device including:
 - an elongate catheter body having a proximal end and a distal end; and
 - at least one tissue apposition member at or near the catheter body distal end configured to bring tissues adjacent the patent foramen ovale at least partially together, the at least one tissue apposition member comprising a first tissue apposition member configured to contact septum secundum tissue adjacent the patent foramen ovale from the right atrium of the heart without penetrating the septum secundum tissue, and a second tissue apposition member configured to pierce into septum primum tissue; and
 - wherein the first and second tissue apposition members comprise two electrodes of a bipolar radiofrequency (RF) device, and the first and second tissue apposition members are configured to grasp and apply energy to the septum secundum tissue and the septum primum tissue to substantially close the patent foramen ovale acutely.
2. A catheter device as in claim 1, wherein the first and second tissue apposition members comprise opposable jaws, and wherein the second member is advanceable through the septum primum tissue, adjacent the patent foramen ovale.
3. A catheter device as in claim 1, wherein the second tissue apposition member is configured for advancing through the patent foramen ovale to contact the septum primum tissue from the left atrium of the heart.
4. A catheter device as in claim 1 or 3, wherein at least one of the first and second tissue apposition members comprises an expandable member.
5. A catheter device as in claim 1 or 3, wherein both the first and second tissue apposition members comprise an expandable member, and wherein at least one of the expandable members is slidably disposed along the catheter body so as to be axially movable toward the other expandable member.

6. A catheter device as in claim 1 or 3, wherein one of the first and second members comprises an expandable member and the other of the first and second members comprises a deployable shaped portion, wherein the expandable member and the shaped portion are brought together to bring the tissues together.
7. A catheter device as in claim 6, wherein the deployable shaped portion comprises a shape memory material that changes from an undeployed to a deployed shape when released from the catheter body.
8. A catheter device as in any one of claims 4 to 7, wherein the expandable member includes at least one aperture for releasing conductive fluid to contact the tissues.
9. A catheter device as in any one of claims 4 to 7, wherein the expandable member includes a plurality of small apertures for releasing conductive fluid to contact the tissues.
10. A catheter device as in claim 3, wherein the first and second tissue apposition members comprise a clamp for clamping the tissues together.
11. A catheter device as in claim 3, wherein the first tissue apposition member has a first deployed shape and the second tissue apposition member has a second deployed shape, and wherein the first and second members, when deployed to contact the tissues, caused the tissues to be brought together.
12. A catheter device as in claim 11, wherein the first shape comprises approximately a curved hook for curving over an edge of the patent foramen ovale to apply force to the tissues from the left atrium, and wherein the second shape comprises approximately a straight, linear shape for applying pressure to the tissues from the right atrium.
13. A catheter device as in claim 3, wherein the first and second tissue apposition members comprise magnets having opposite polarity.
14. A catheter device as in claim 3, wherein the first tissue apposition member comprises a pair of opposable jaws for contacting the septum secundum tissue from the right atrium, and the

second tissue apposition member comprises a curved member for advancing through the patent foramen ovale to contact the septum primum tissue from the left atrium.

15. A catheter device as in claim 1, wherein the at least one tissue apposition member comprises:

at least two tissue apposition members for moving relative to one another to bring the tissues together between them; and

at least one biasing member for biasing the tissue apposition members toward a first side of the patent foramen ovale.

16. A catheter device as in claim 15, wherein the tissue apposition members are movable along the patent foramen ovale from the first side to a second opposite side of the patent foramen ovale.

17. A catheter device as in claim 16, wherein the catheter body has a cross-sectional shape such that when the tissues are brought together between the two tissue apposition members, the tissues urge the catheter body to a different position relative to the patent foramen ovale.

18. A catheter device as in claim 17, wherein the shape is selected from the group consisting of triangular, oval, elliptical and diamond shaped.

19. A catheter device as in claim 17, wherein the two tissue apposition members comprise:
one shape-memory tissue apposition member; and
one jaw member.

20. A catheter device as in claim 17, further comprising at least one aperture on the catheter body for releasing one or more fluids to enhance the application of energy to the tissues to close the patent foramen ovale.

21. A catheter device as in claim 17, further comprising a coating over the catheter body, the coating enhancing application of energy to the tissues when the tissues contact the catheter body.

22. A catheter device as in claim 1, wherein the at least one tissue apposition member comprises an expandable member releasably disposed within the catheter body, wherein advancing the expandable member out the distal end of the catheter body or retracting the catheter body relative to the expandable member allows the expandable member to expand within the patent foramen ovale.
23. A catheter device as in claim 22, wherein the expandable member comprises two prongs that expand apart to provide lateral force to the tissues adjacent the patent foramen ovale.
24. A catheter device as in claim 23, wherein the prongs are configured to remain substantially within the right atrium of the heart.
25. A catheter device as in claim 23, wherein the prongs are spring loaded.
26. A catheter device as in claim 23, wherein the prongs comprise a shape memory material.
27. A catheter device as in claim 23 wherein the prongs include at least one vacuum aperture for applying vacuum force to further bring the tissues together.
28. A catheter device as in claim 1, further comprising a guide member for advancing through the patent foramen ovale, wherein the catheter device is slidably disposed over the guide member.
29. A catheter device as in claim 28, wherein the guide member comprises a guidewire divided along a portion of its length, the divided portion comprising expandable shape memory material.
30. A catheter device as in claim 28, wherein the guide member comprises at least one tip for contacting a left atrial surface of the tissues adjacent the patent foramen ovale.
31. A catheter device as in claim 30, wherein the at least one tip is conformable to the left atrial surface.

32. A catheter device as in claim 30, wherein the guide member is retractable to engage the at least one tip with the left atrial surface.
33. A catheter device as in claim 28, wherein the guide member comprises at least one of the electrodes.
34. A catheter device as in claim 33, wherein the guide member comprises an expandable member for expanding within the patent foramen ovale, and wherein the expandable member comprises the at least one electrode.
35. A catheter device as in claim 1, wherein at least one of the electrodes is movable relative to at least one of the tissue apposition members.
36. A catheter device as in claim 1, wherein at least one of the electrodes is coupled with at least one of the tissue apposition members.
37. A catheter device as in claim 1, wherein at least one of the electrodes comprises at least one of the tissue apposition members.
38. A catheter device as in claim 1, wherein at least one of the electrodes is disposed within an expandable member, the expandable member including at least one aperture for releasing fluid to contact the tissues; and wherein the device comprises at least one conductive fluid disposed within the expandable member and exposed to a radiofrequency transmission member.
39. A catheter device as in claim 1, wherein at least one of the electrodes comprises at least one curved transmission member.
40. A catheter device as in claim 1, wherein at least one of the electrodes comprises at least one of a mesh material and a braid material.
41. A catheter device as in claim 1, wherein at least one of the electrodes comprises a guide member for advancing through the patent foramen ovale.

42. A catheter device as in claim 41, wherein the guide member includes at least one expandable portion for expanding within the patent foramen ovale to at least partially bring together the tissues adjacent the patent foramen ovale.
43. A catheter device as in any one of claims 1 to 42, further comprising at least one sensor coupled with the catheter device for sensing an amount of energy delivered to the tissues by the electrodes.
44. A catheter device as in claim 43, wherein the at least one sensor is selected from the group consisting of an infrared sensing device, thermistors and thermocouples.
45. A catheter device as in claim 43 or 44, further comprising a microprocessor coupled with the at least one sensor for processing sensed data to determine when the amount of delivered energy has reached a desired amount of energy.
46. A catheter device as in any one of claims 1 to 42, further comprising a microprocessor coupled with the catheter device for sensing and controlling energy transmission by the electrodes.
47. Use of a catheter device as defined in any one of claims 1 to 46, for treating a patent foramen ovale in a heart.
48. A system for treating a patent foramen ovale in a heart, the system comprising at least one guide member for guiding a catheter device to a position for treating the patent foramen ovale and said catheter device, wherein the catheter device comprises:
an elongate catheter body having a proximal end and a distal end; and
at least one tissue apposition member at or near the catheter body distal end configured to bring tissues adjacent the patent foramen ovale at least partially together, the at least one tissue apposition member comprising a first tissue apposition member configured to contact septum secundum tissue adjacent the patent foramen ovale from a right atrium of the heart without penetrating the septum secundum tissue, and a second tissue apposition member configured to pierce into a septum primum tissue; wherein the first and second tissue apposition members comprise two electrodes of a bipolar

radiofrequency (RF) device, and the first and second tissue apposition members are configured to grasp and apply energy to the septum secundum tissue and the septum primum tissue to substantially close the patent foramen ovale acutely;

wherein at least one of the tissue apposition members comprises an expandable member releasably disposed within the catheter body, wherein advancing the expandable member out the distal end of the catheter body allows the expandable member to expand within the patent foramen ovale; and

wherein the expandable member comprises at least two members that expand apart to provide lateral force to the tissues adjacent the patent foramen ovale.

49. A system as in claim 48, wherein the first and second tissue apposition members comprise opposable jaws.

50. A system as in claim 48 or 49, wherein the second apposition member is advanceable through the septum primum tissue.

51. A system as in claim 48 or 49, wherein the second tissue apposition member is configured for contacting the septum primum tissue from the left atrium of the heart.

52. A system as in claim 51, wherein the second tissue apposition member is advanceable through the patent foramen ovale into the left atrium to contact the tissue.

53. A system as in claim 48, wherein both the first and second tissue apposition members comprise expandable members, and wherein at least one of the expandable members is slidably disposed along the catheter body so as to be axially movable toward the other expandable member.

54. A system as in claim 48, wherein one of the first and second members comprises the expandable member and the other of the first and second members comprises a deployable shaped portion, wherein the expandable member and the shaped portion are brought together to bring the tissues together.

55. A system as in claim 54, wherein the deployable shaped portion comprises a shape memory material that changes from an undeployed to a deployed shape when released from the catheter body.
56. A system as in claims 53, 54 or 55, wherein the expandable member includes at least one aperture for releasing a conductive fluid to contact the tissues.
57. A system as in claims 53, 54 or 55, wherein the expandable member includes a plurality of small apertures for releasing a conductive fluid to contact the tissues.
58. A system as in claim 48, wherein the first and second tissue apposition members comprise a clamp for clamping the tissues together.
59. A system as in claim 48, wherein the first and second tissue apposition members are for moving relative to one another to bring the tissues together between them; and wherein the catheter device further comprises at least one biasing member for biasing the tissue apposition members toward a first side of the patent foramen ovale.
60. A system as in claim 59, wherein the first and second tissue apposition members are movable along the patent foramen ovale from the first side to an opposite side of the patent foramen ovale.
61. A system as in claim 48, wherein the expandable member is configured to provide the lateral force while remaining substantially within the right atrium of the heart.
62. A system as in claim 48, wherein the expandable member comprises a spring loaded member.
63. A system as in claim 48, wherein the expandable member comprises a shape memory material.
64. A system as in claim 48, wherein the guide member is advancable through the patent foramen ovale, wherein the catheter device is slidably disposed over the guide member.

65. A system as in claim 64, wherein the guide member comprises a guidewire divided along a portion of its length, the divided portion comprising expandable shape memory material.
66. A system as in claim 65, wherein the guide member comprises at least one tip for contacting a left atrial surface of the tissues adjacent the patent foramen ovale.
67. A system as in claim 66, wherein the at least one tip is conformable to the left atrial surface.
68. A system as in claim 66, wherein the guide member is retractable to engage the at least one tip with the left atrial surface.
69. A system as in claim 48, wherein at least one of the electrodes is movable relative to at least one of the tissue apposition members.
70. A system as in claim 48, wherein at least one of the electrodes is coupled with at least one of the tissue apposition members.
71. A system as in claim 48, wherein at least one of the electrodes is disposed within the expandable member, the expandable member including at least one aperture for releasing fluid to contact the tissues; and
at least one conductive fluid disposed within the expandable member and exposed to the electrode.
72. A system as in claim 48, wherein at least one of the electrodes comprises at least one curved radiofrequency transmission member.
73. A system as in claim 48, wherein at least one of the electrodes comprises at least one of a mesh material and a braid material.
74. A system as in any one of claims 48 to 73, further comprising at least one sensor coupled with the catheter device for sensing an amount of energy delivered to the tissues by the electrodes.

75. A system as in claim 74, wherein the at least one sensor is selected from the group consisting of an infrared sensing device, thermistors and thermocouples.

76. A system as in claim 74 or 75, further comprising a microprocessor coupled with the at least one sensor for processing sensed data to determine when the amount of delivered energy has reached a desired amount of energy.

77. A system as in any one of claims 48 to 73, further comprising a microprocessor coupled with the catheter device for sensing and controlling energy transmission by the electrodes.

78. Use of a system as defined in any one of claims 48 to 77, for treating a patent foramen ovale in a heart.

1/14

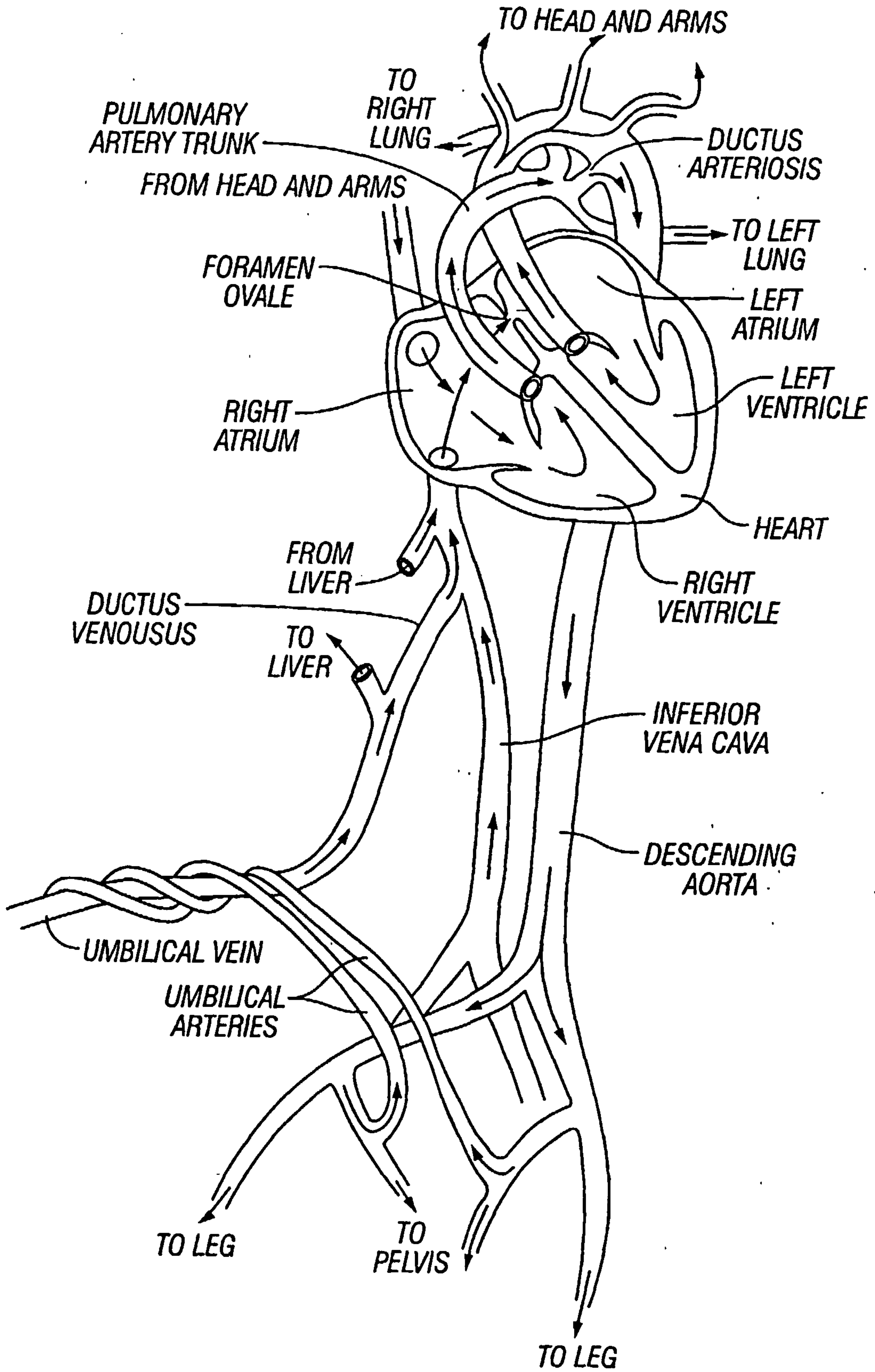

FIG. 1

2/14

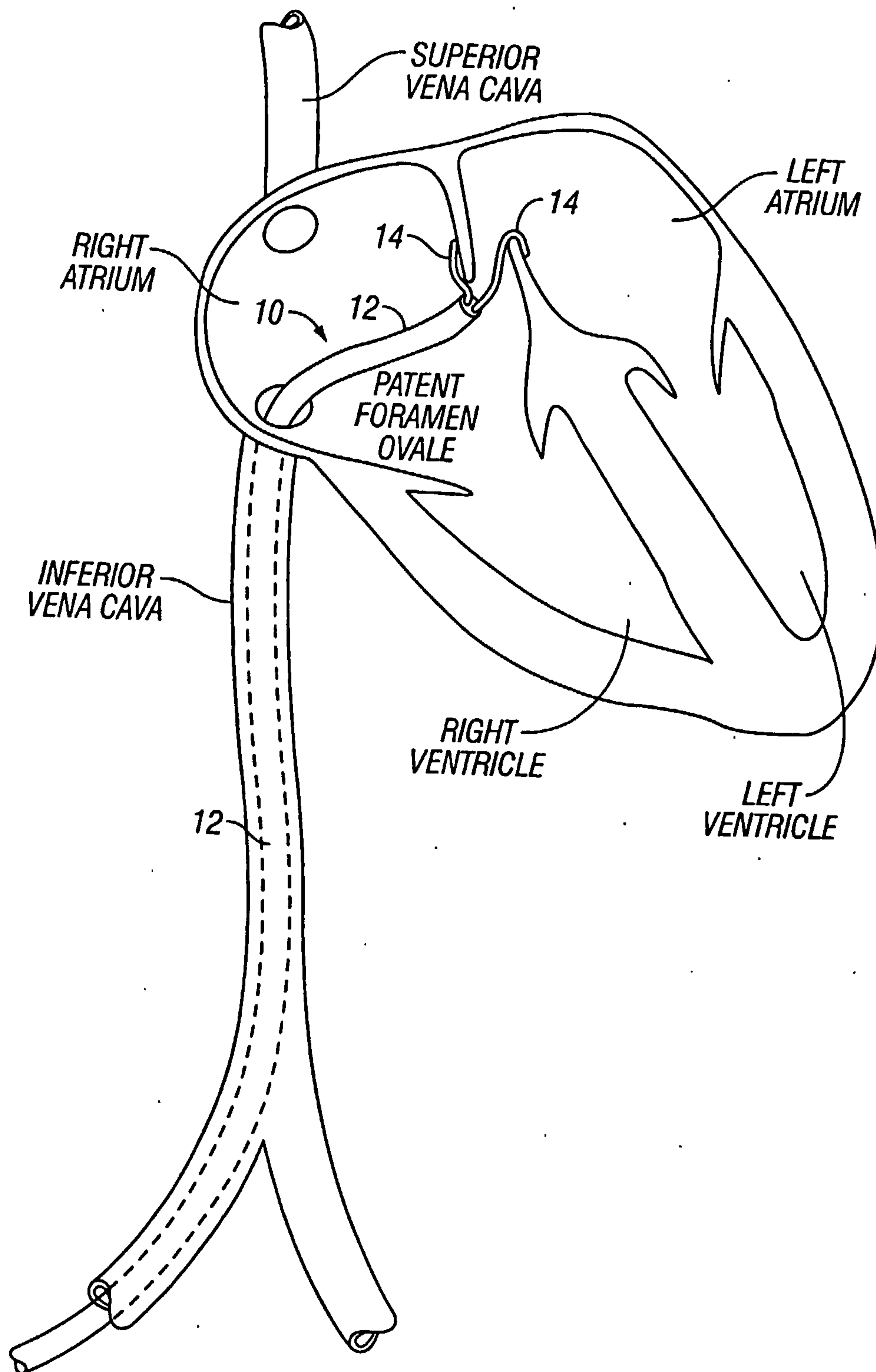

FIG. 2

3/14

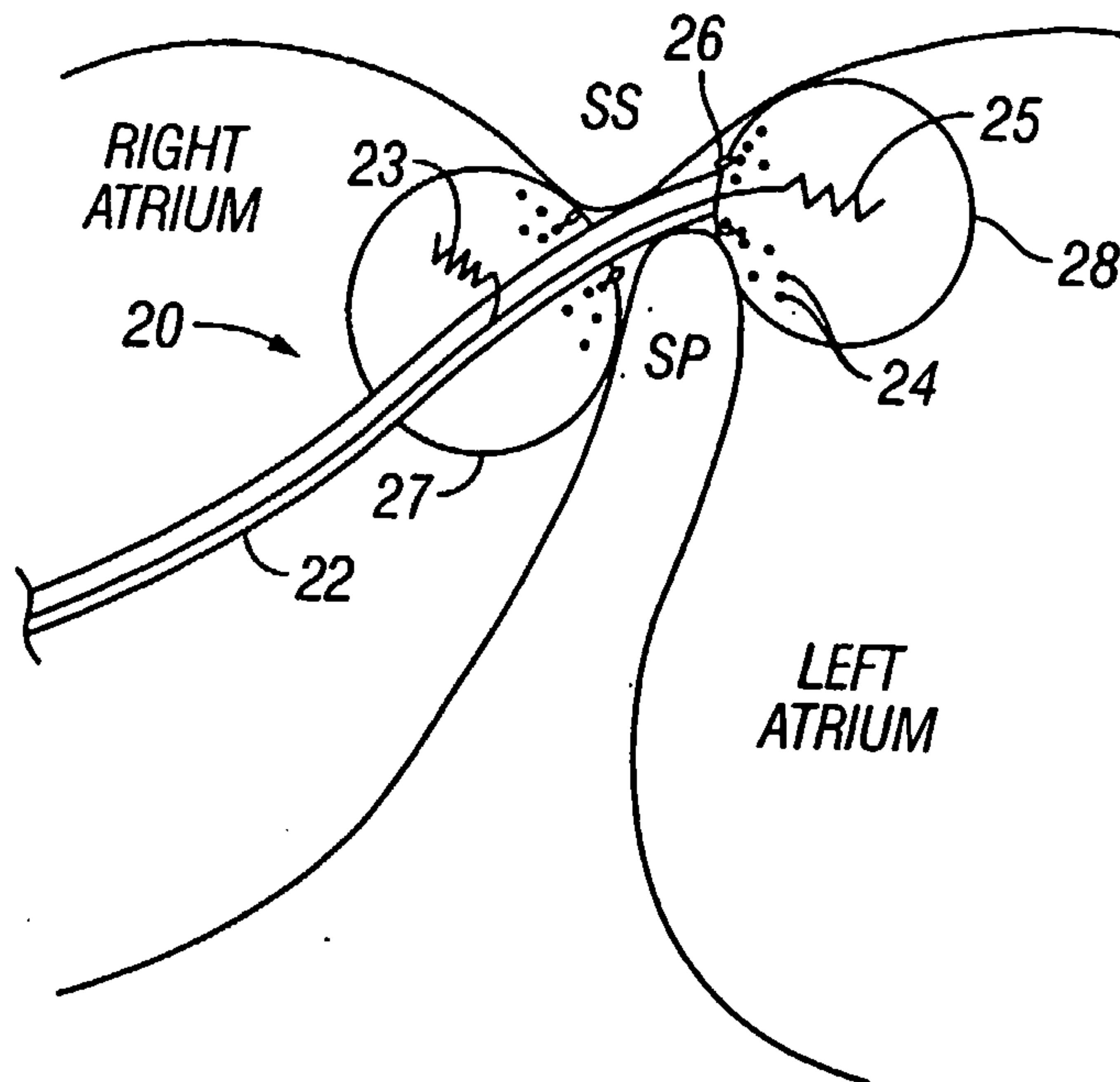

FIG. 3

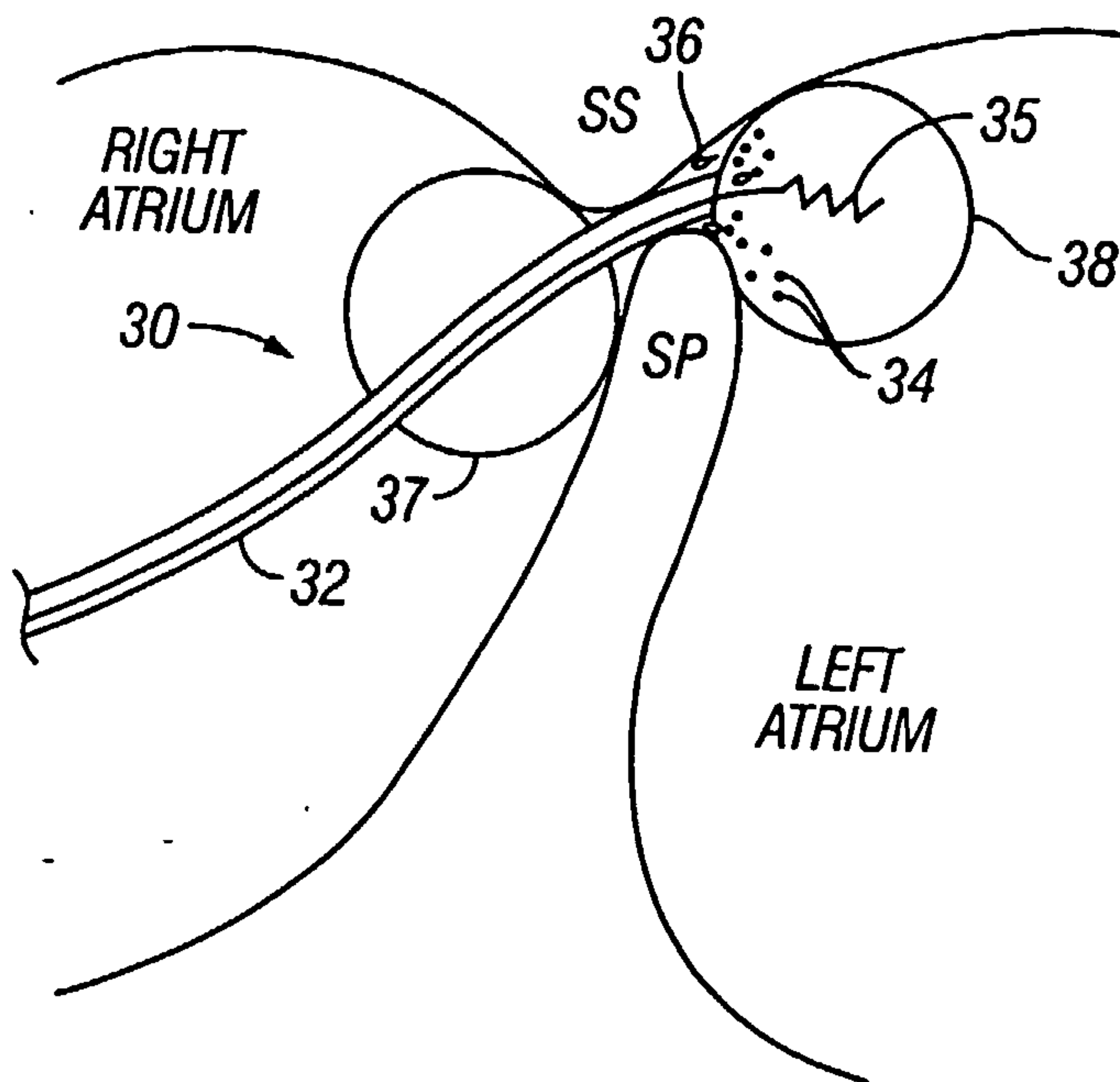

FIG. 4

4/14

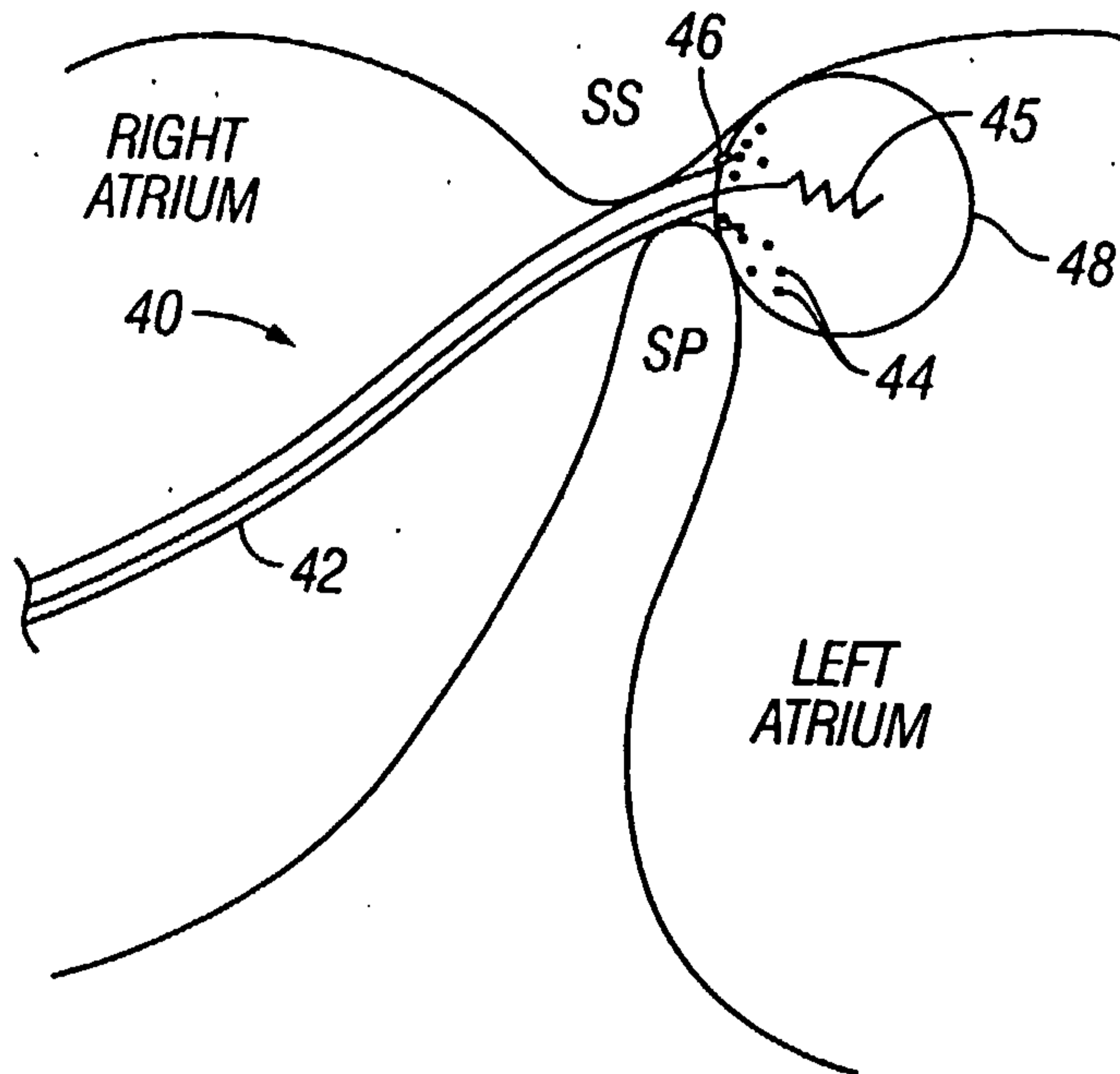

FIG. 5

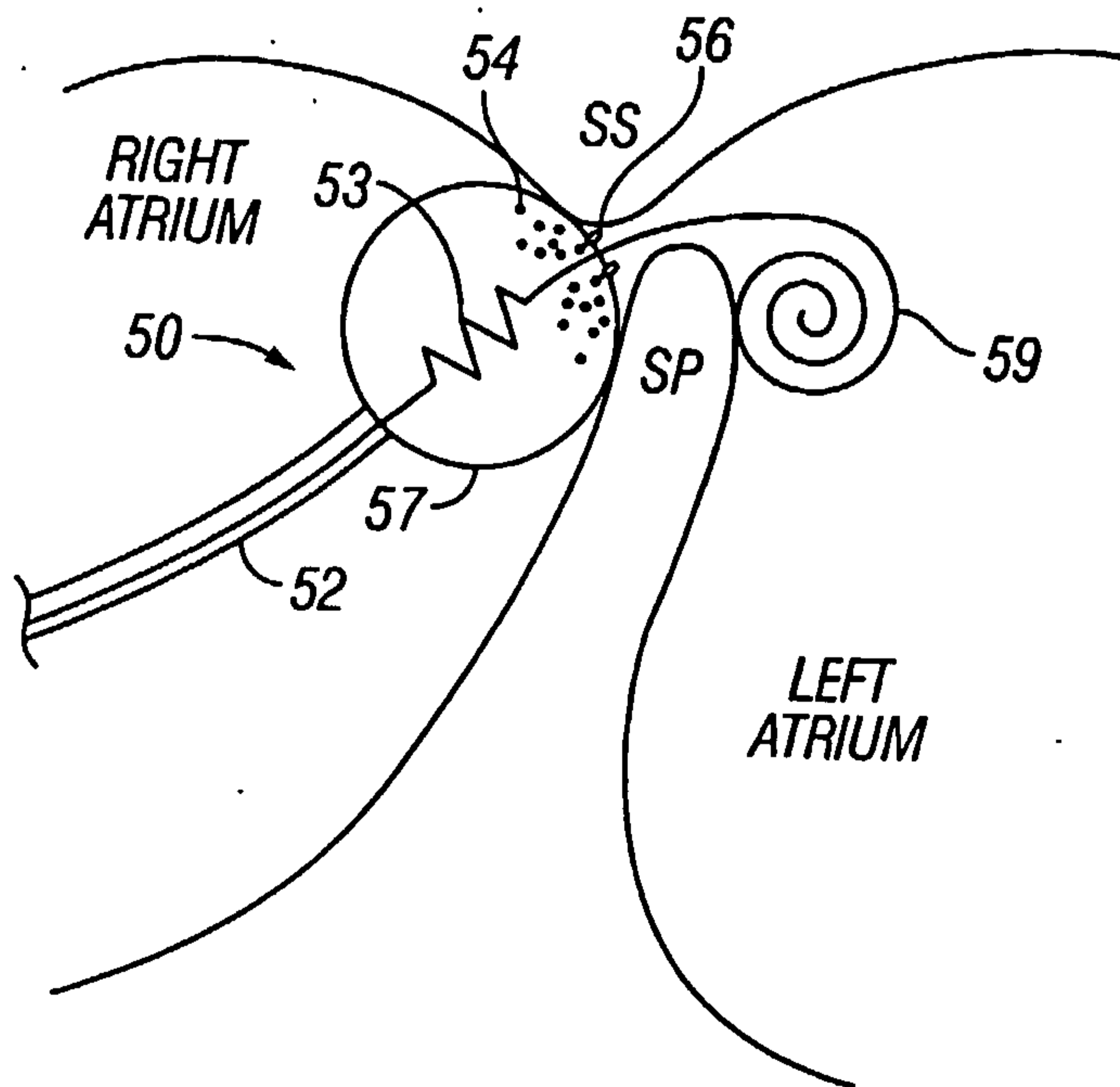

FIG. 6

5/14

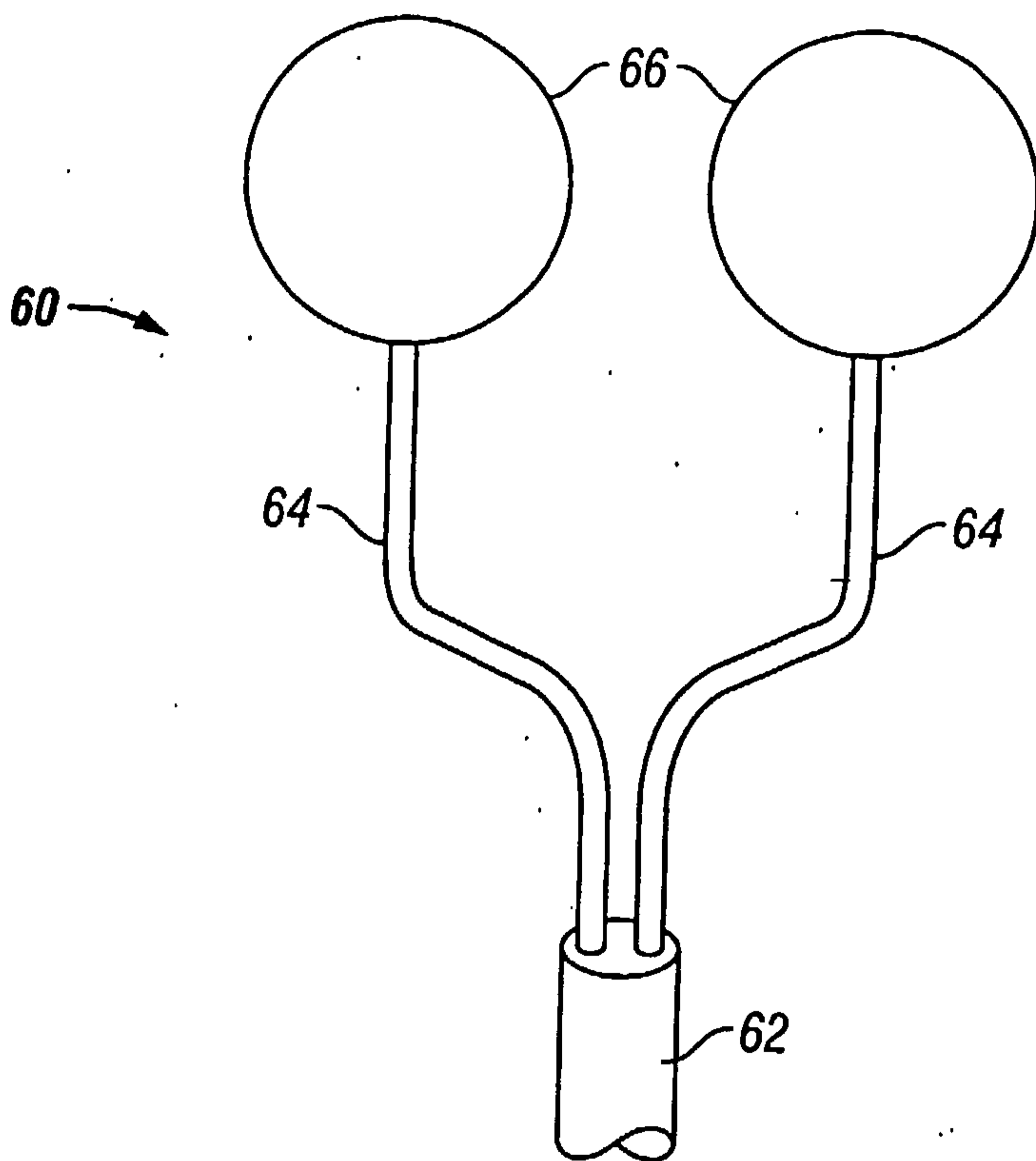

FIG. 7

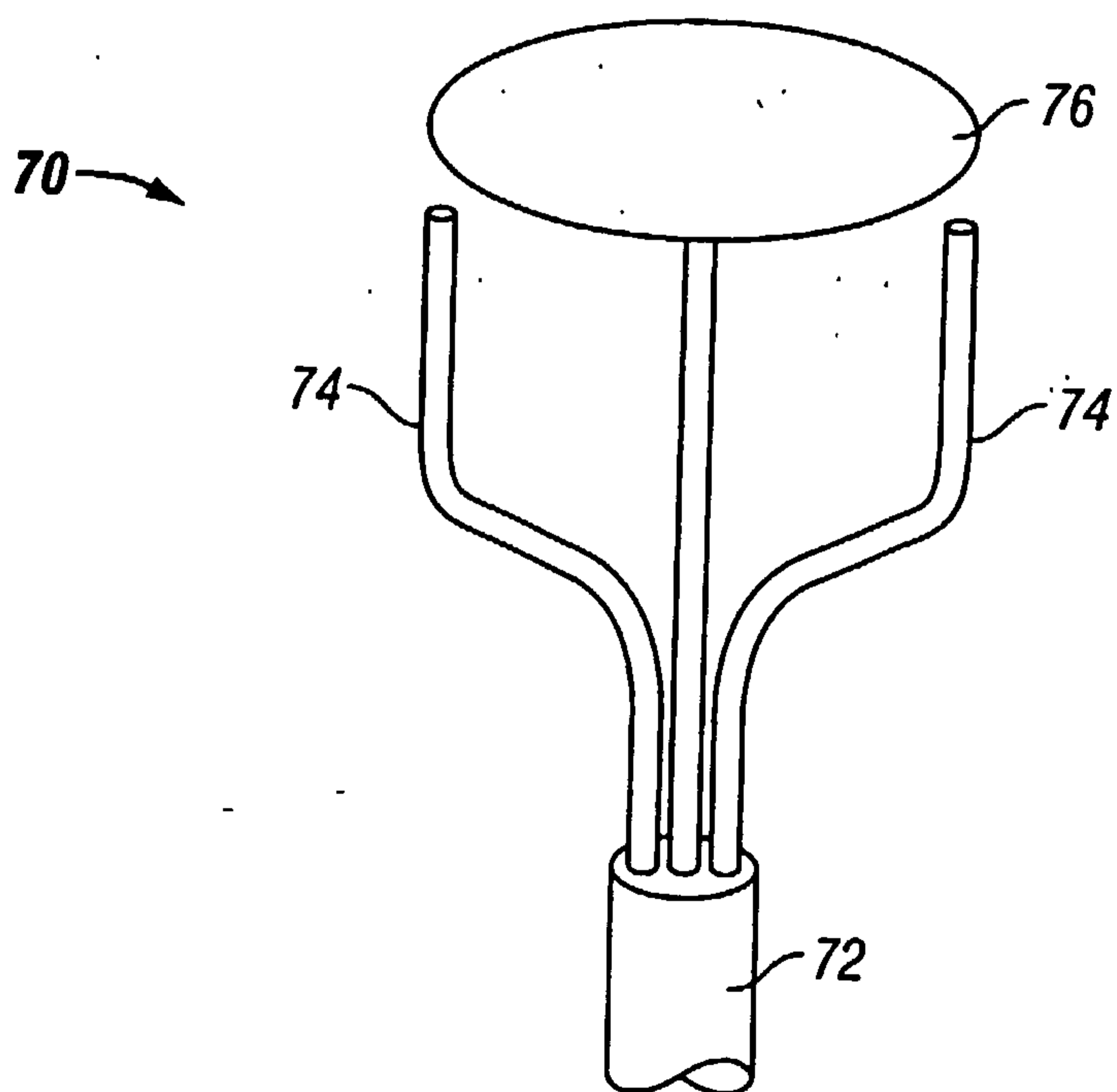

FIG. 8

6/14

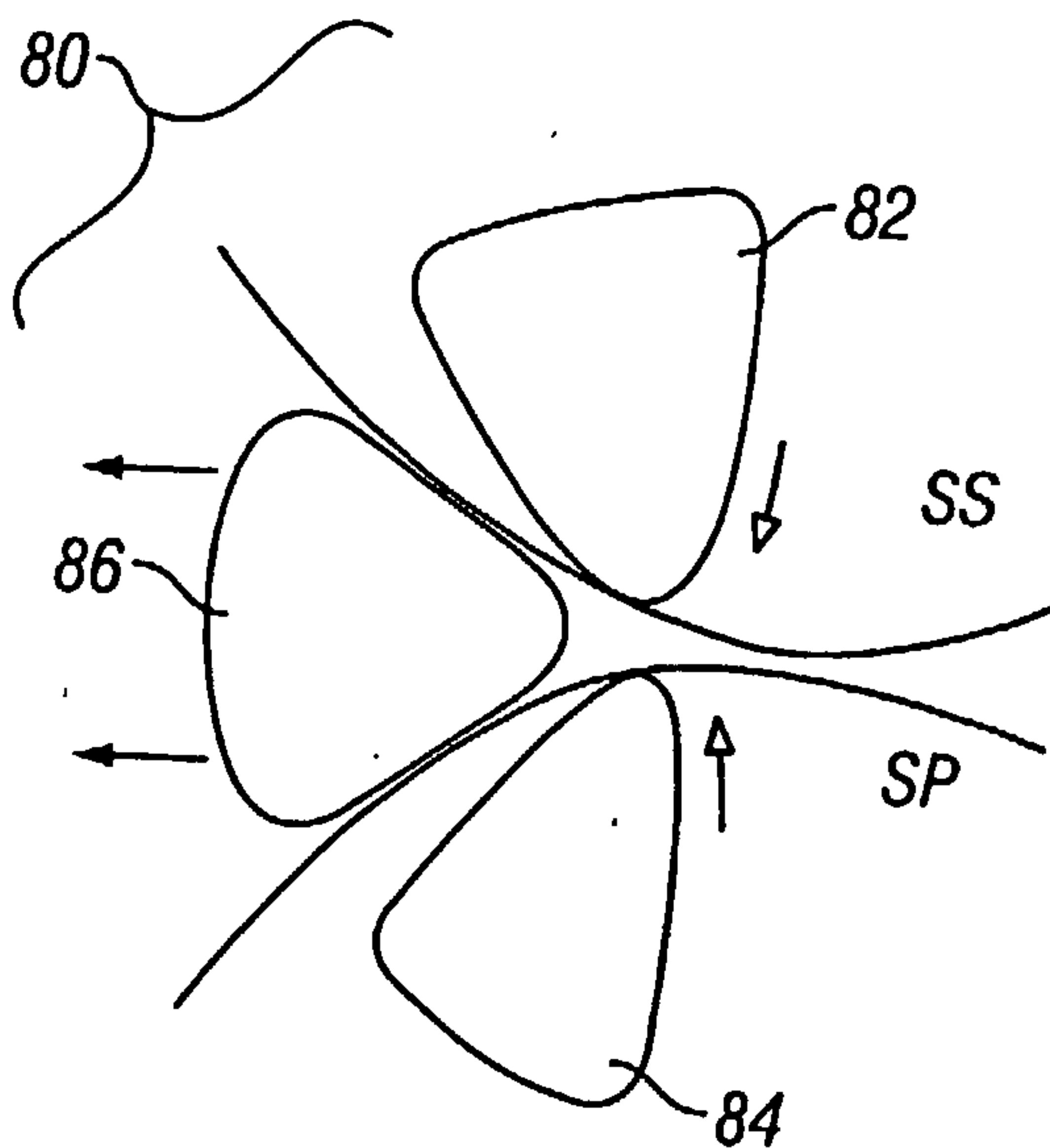

FIG. 9

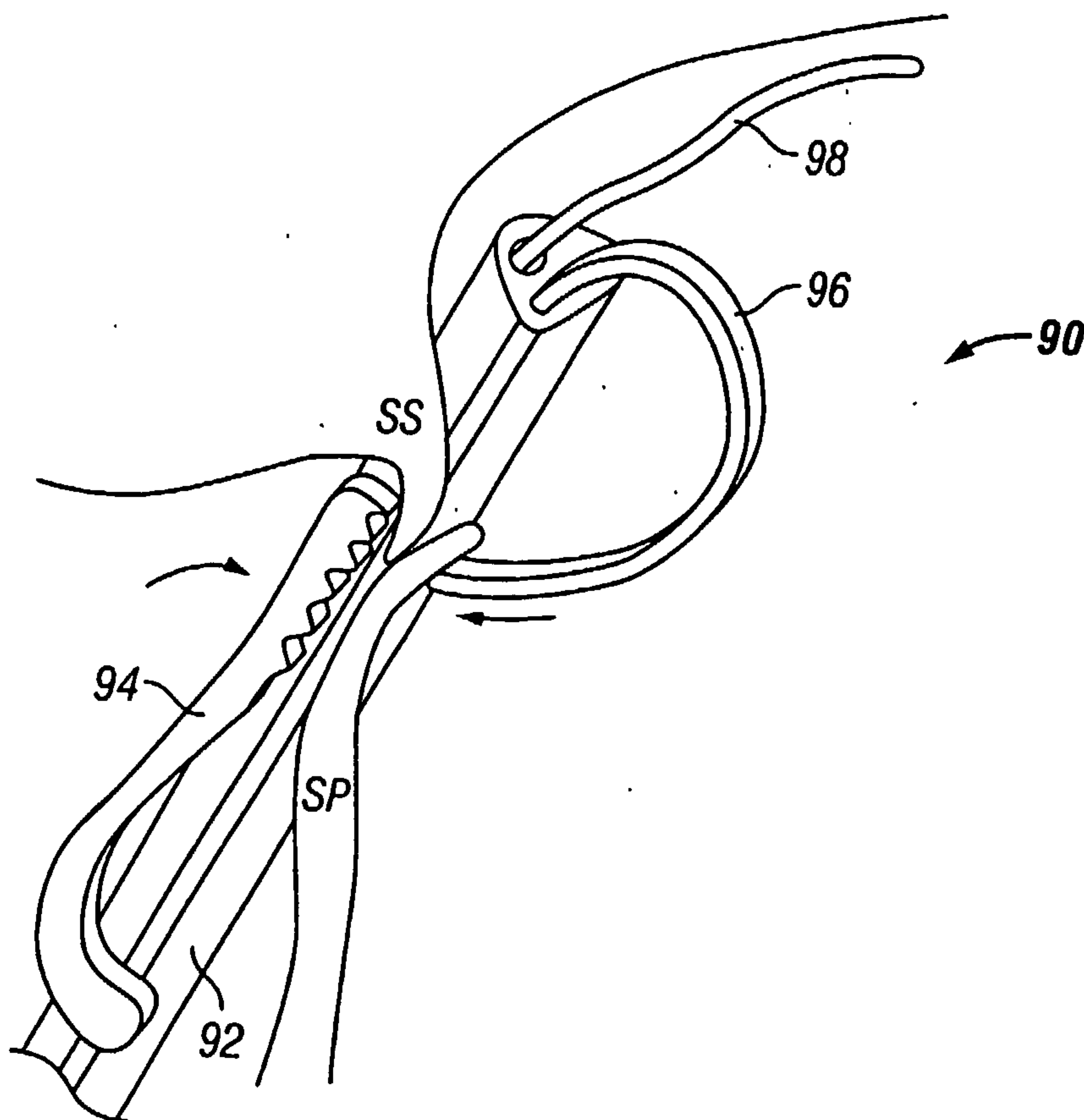

FIG. 10

7/14

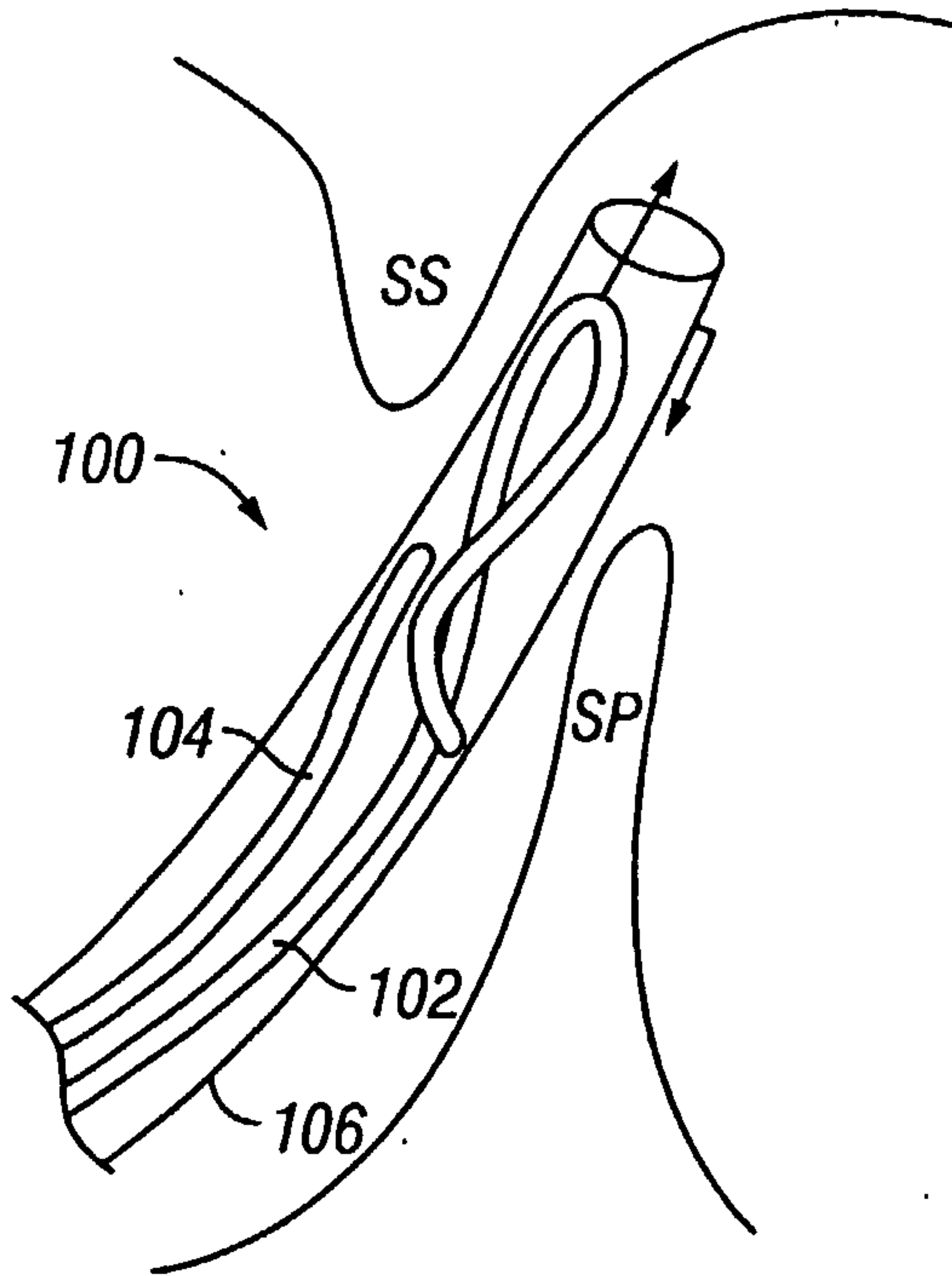

FIG. 11A

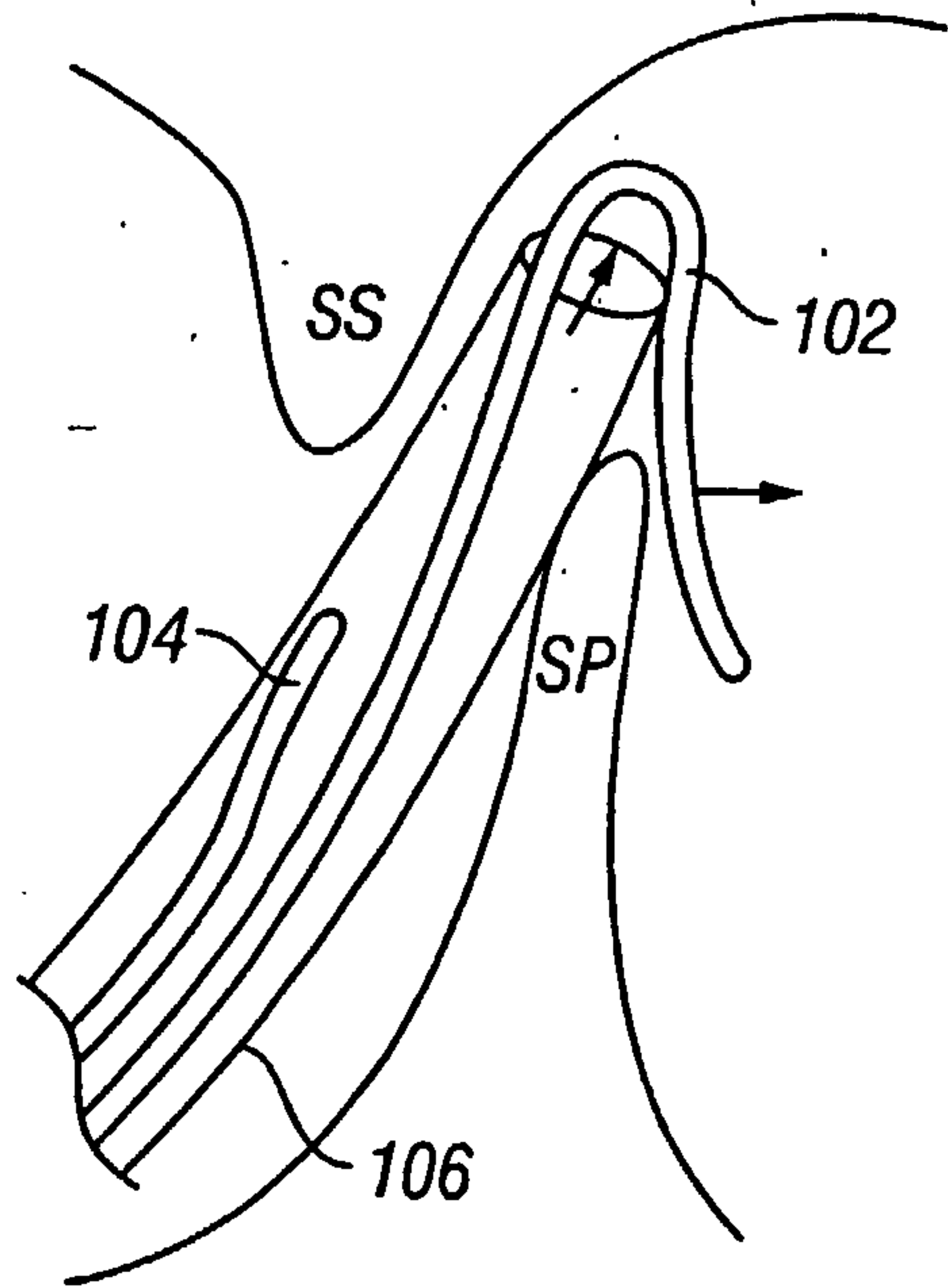

FIG. 11B

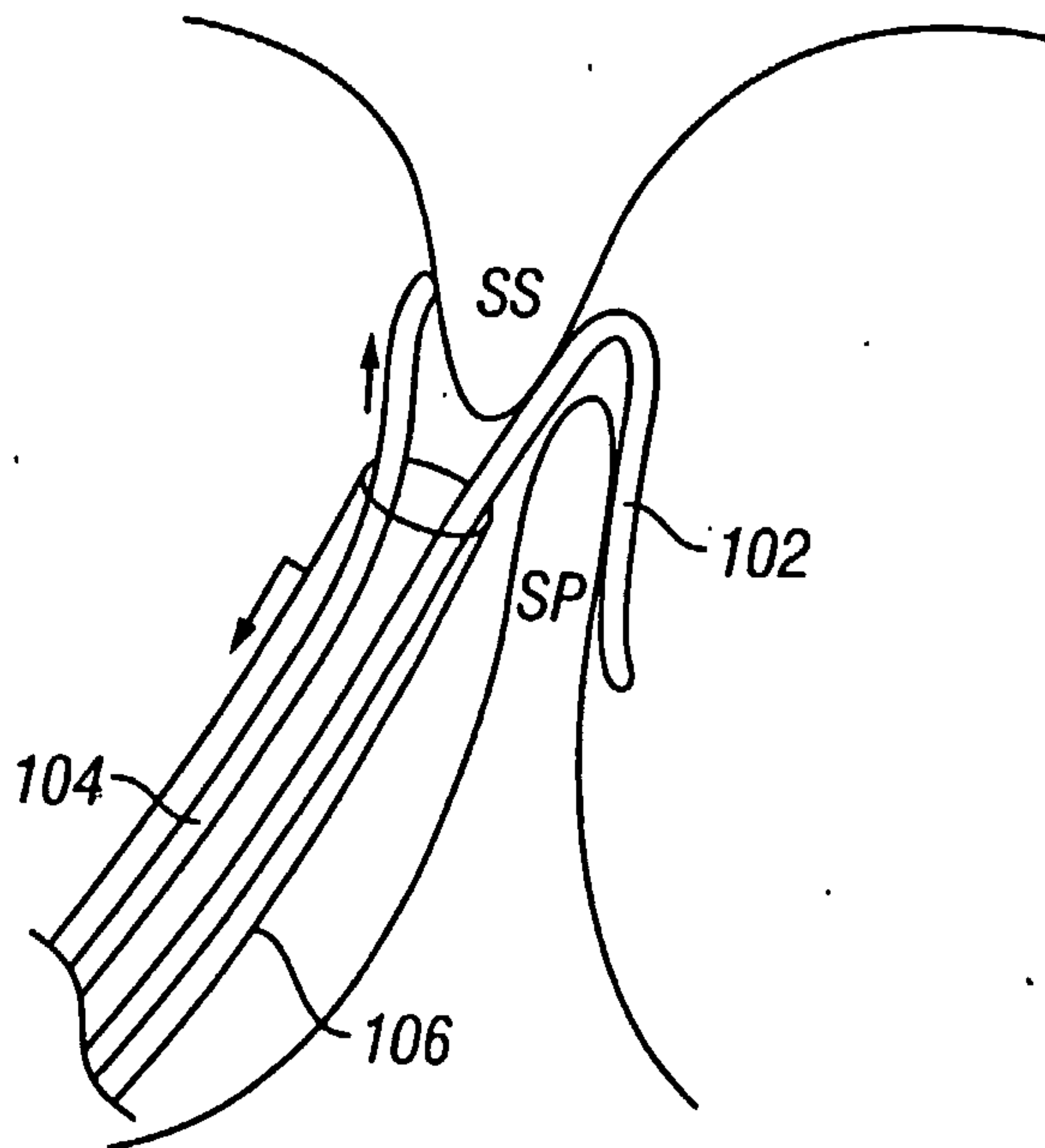

FIG. 11C

8/14

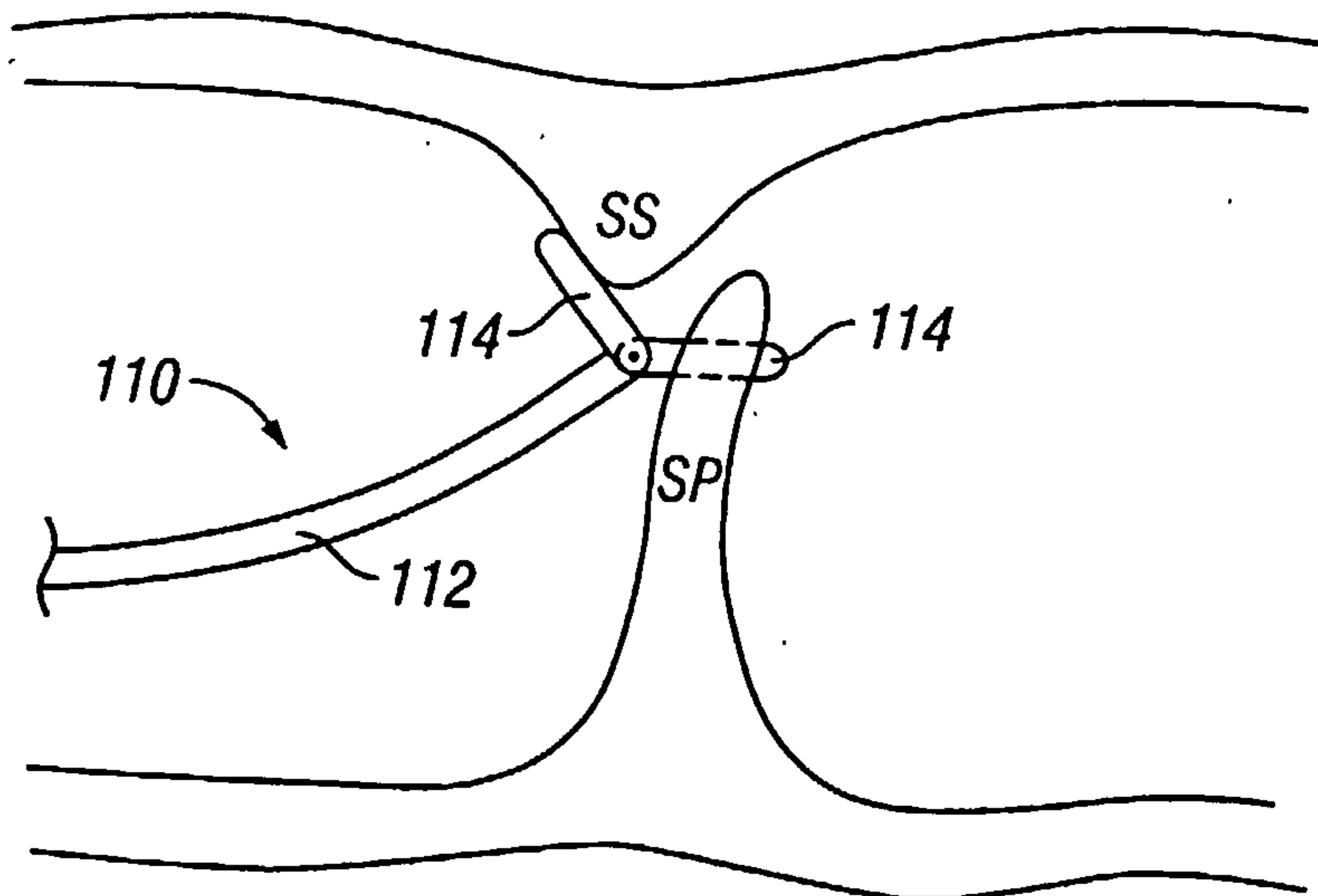

FIG. 12A

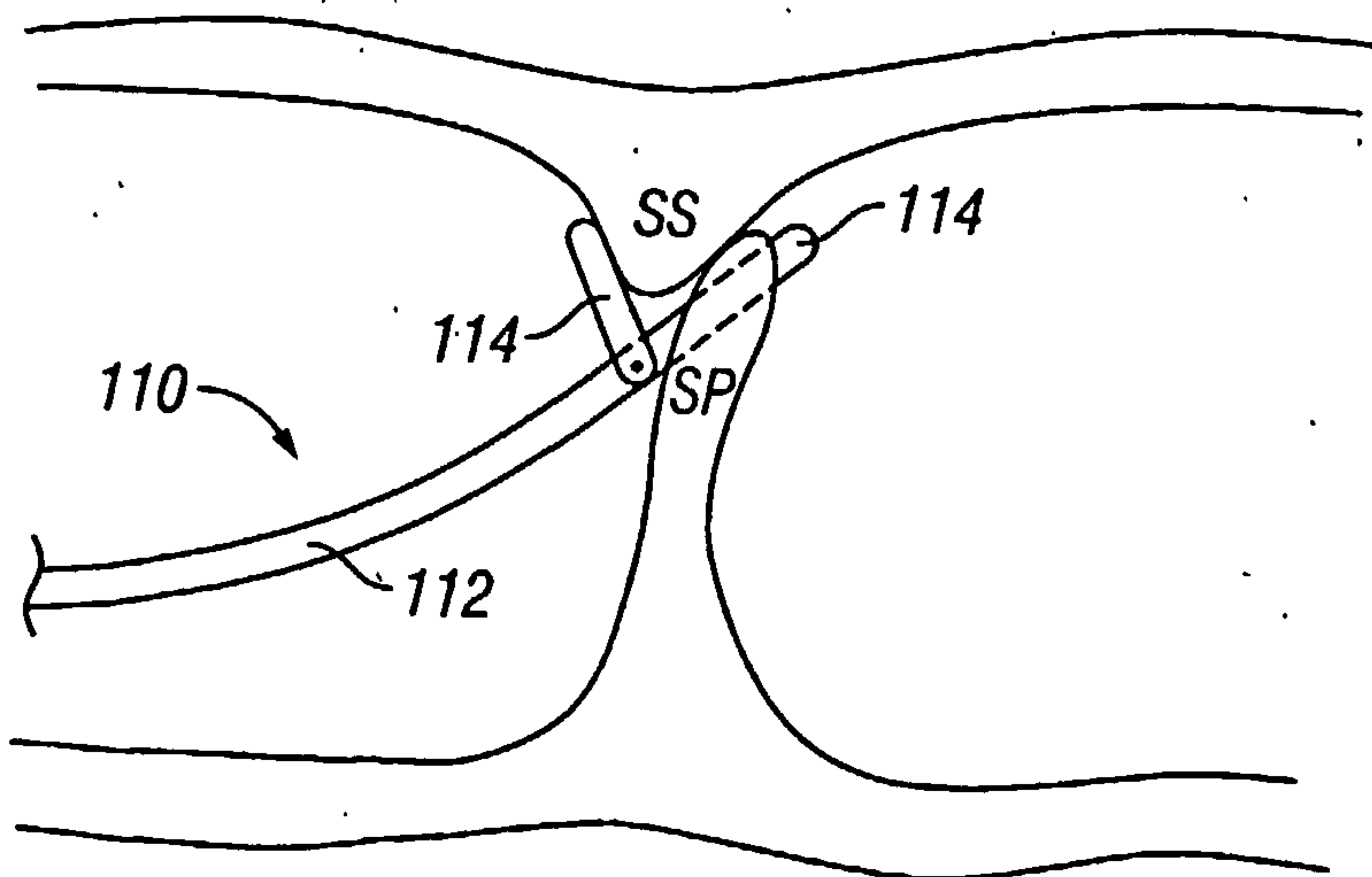

FIG. 12B

9/14

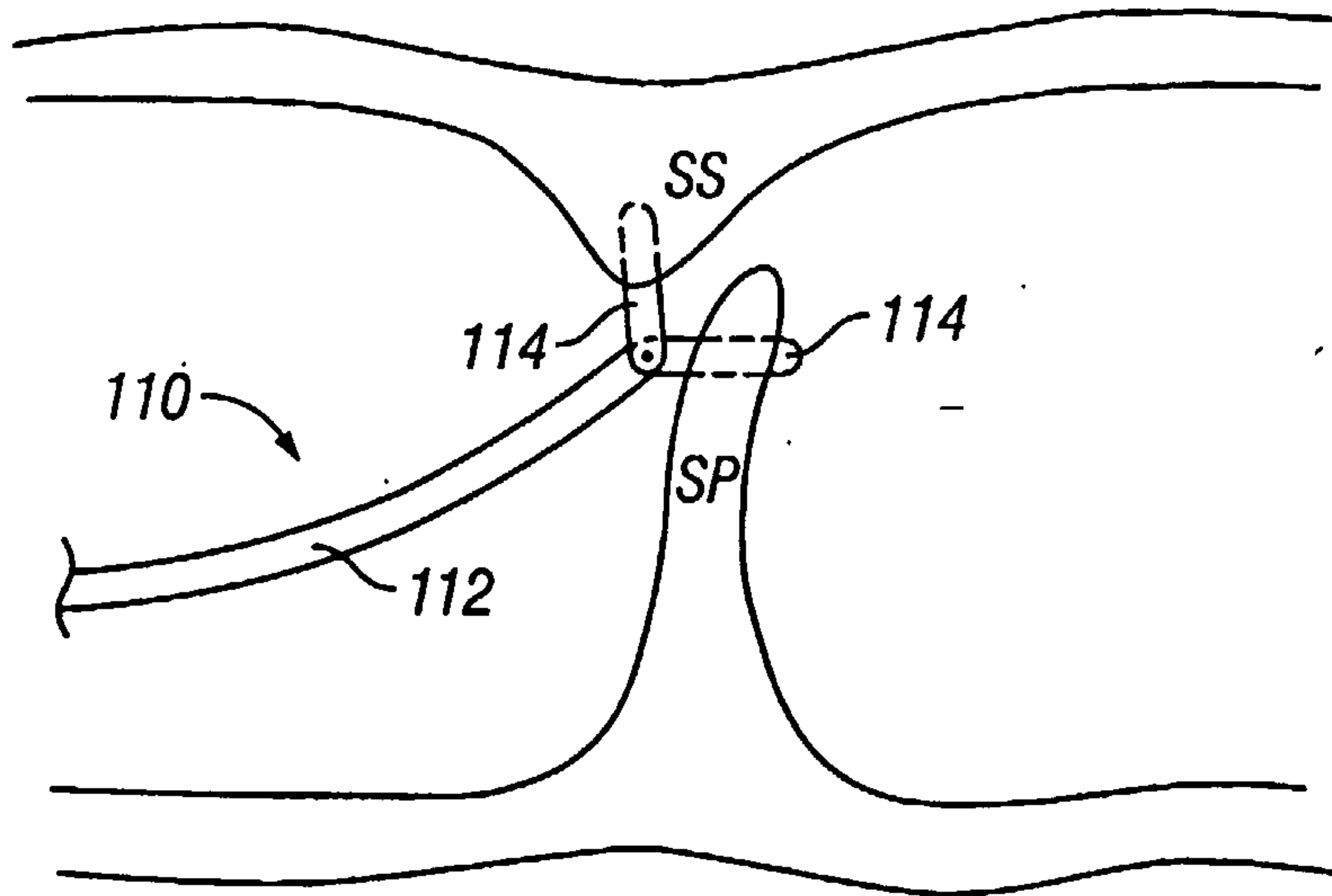

FIG. 13A

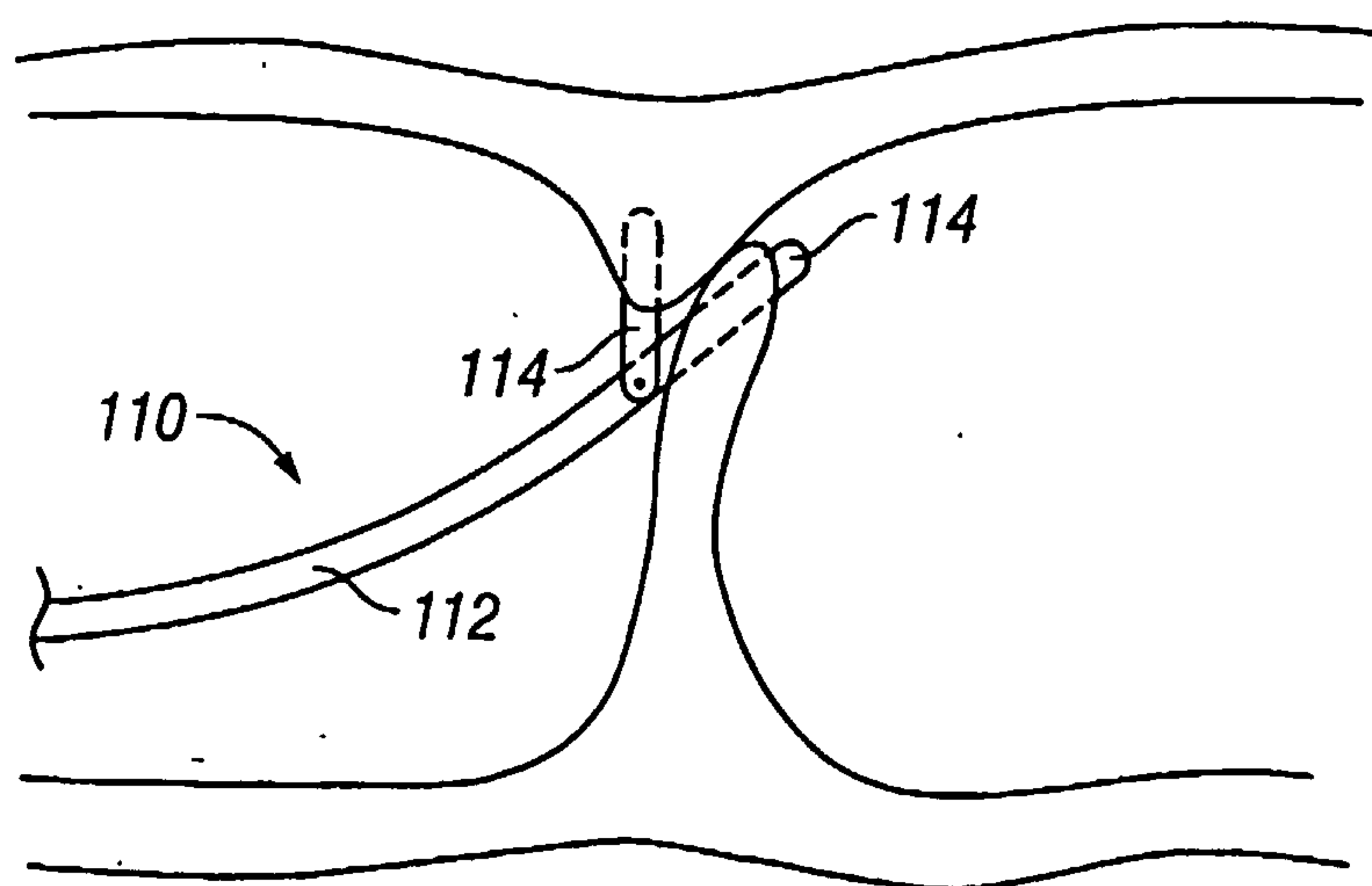

FIG. 13B

10/14

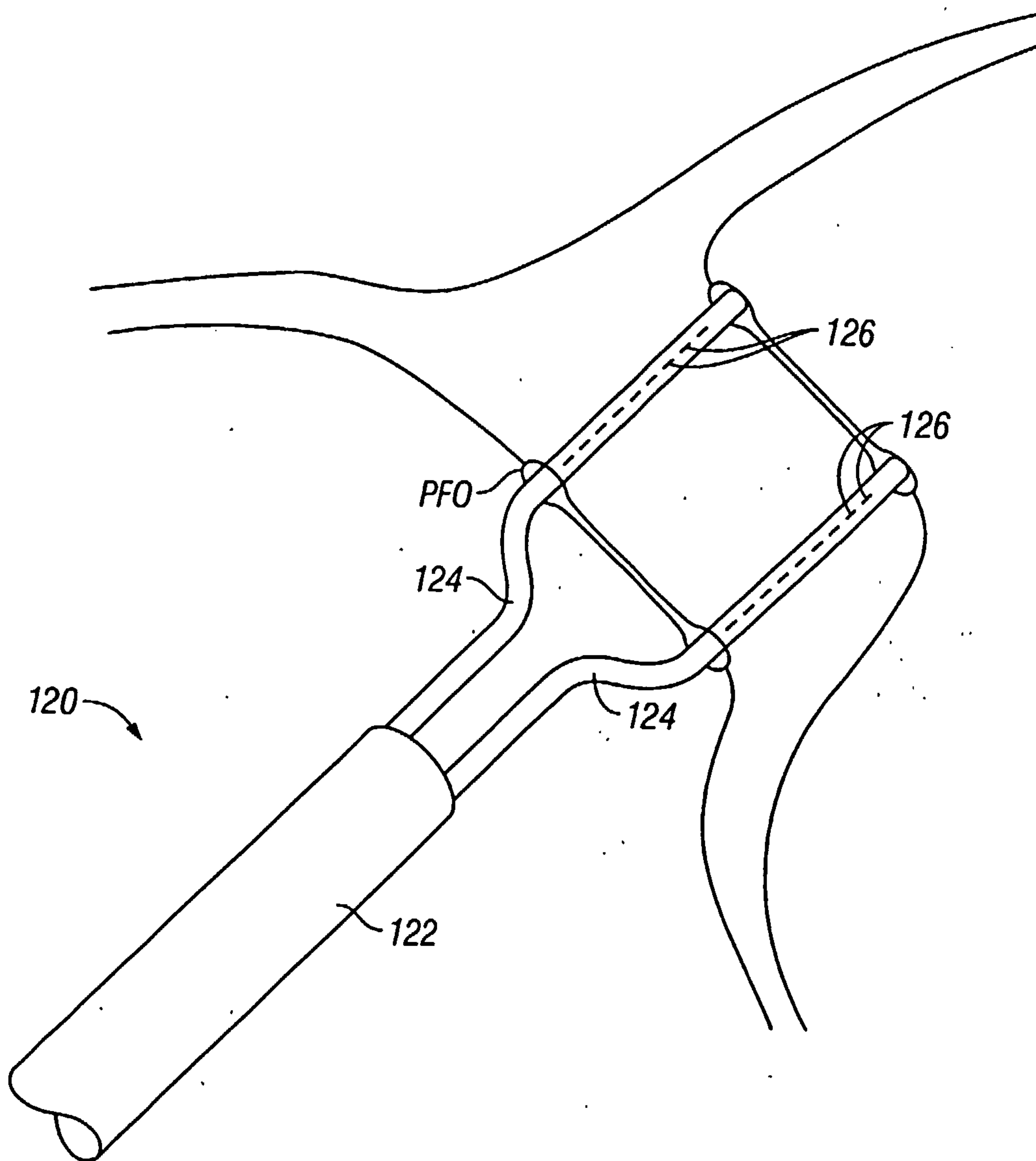

FIG. 14

11/14

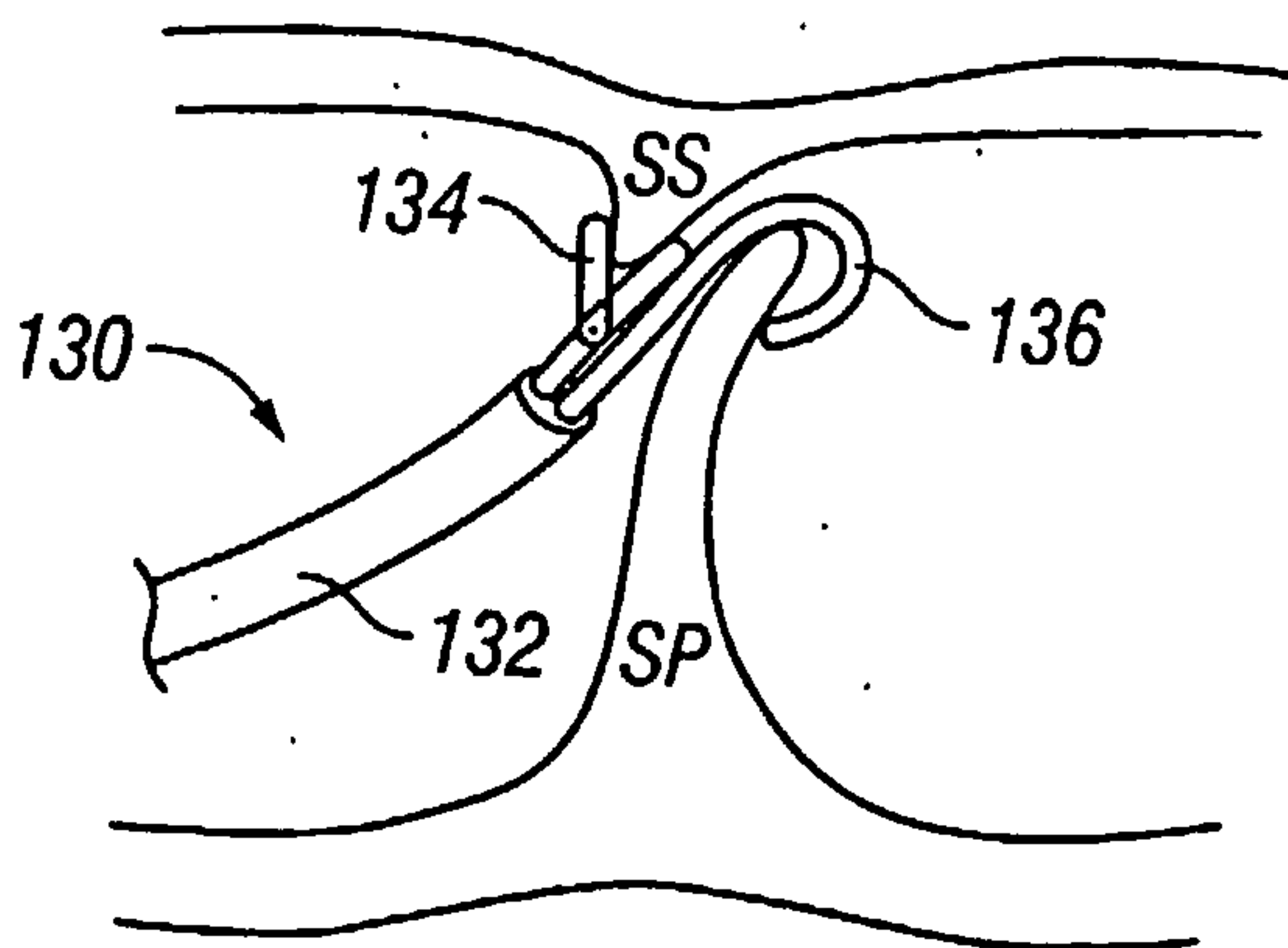

FIG. 15A

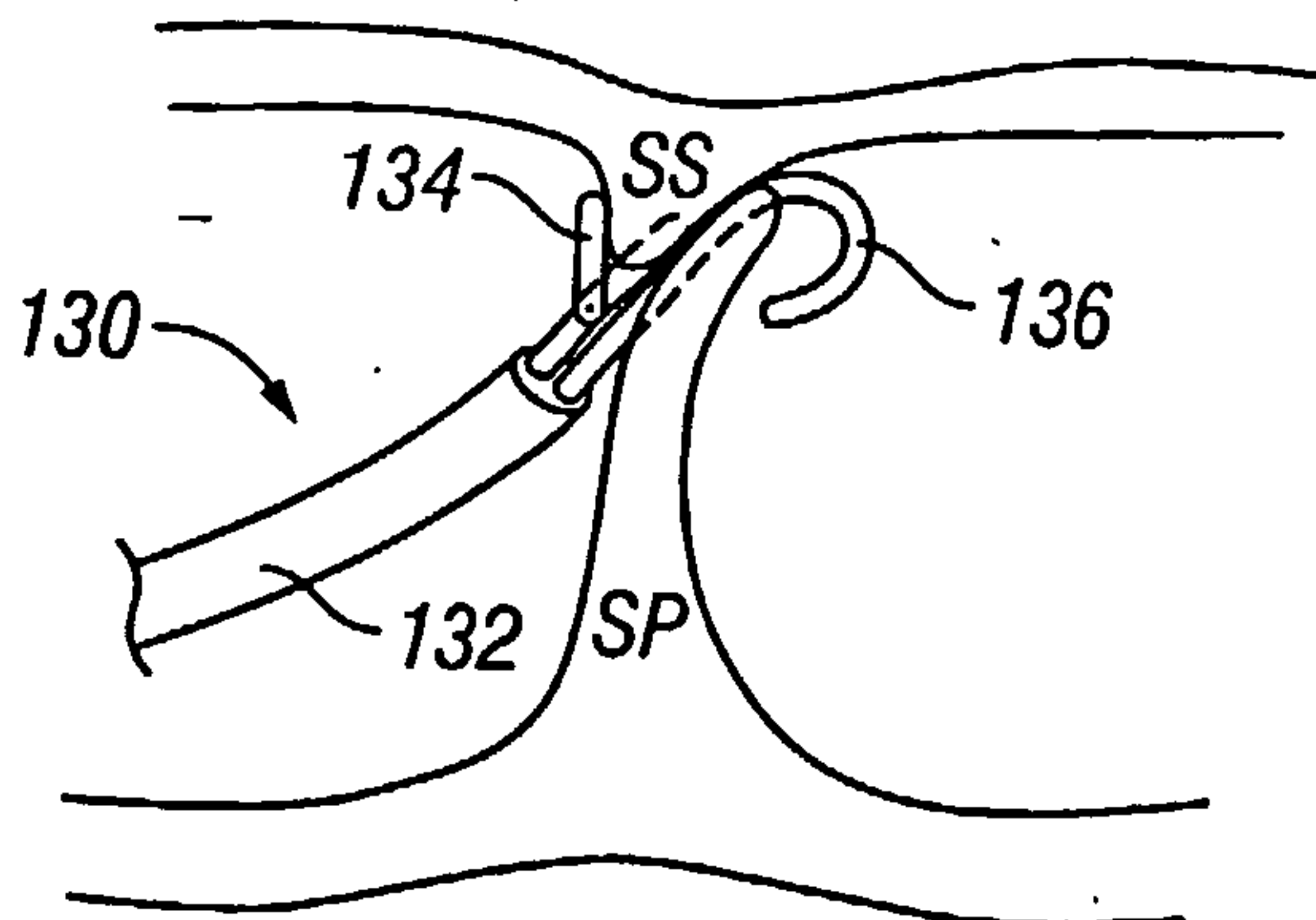

FIG. 15B

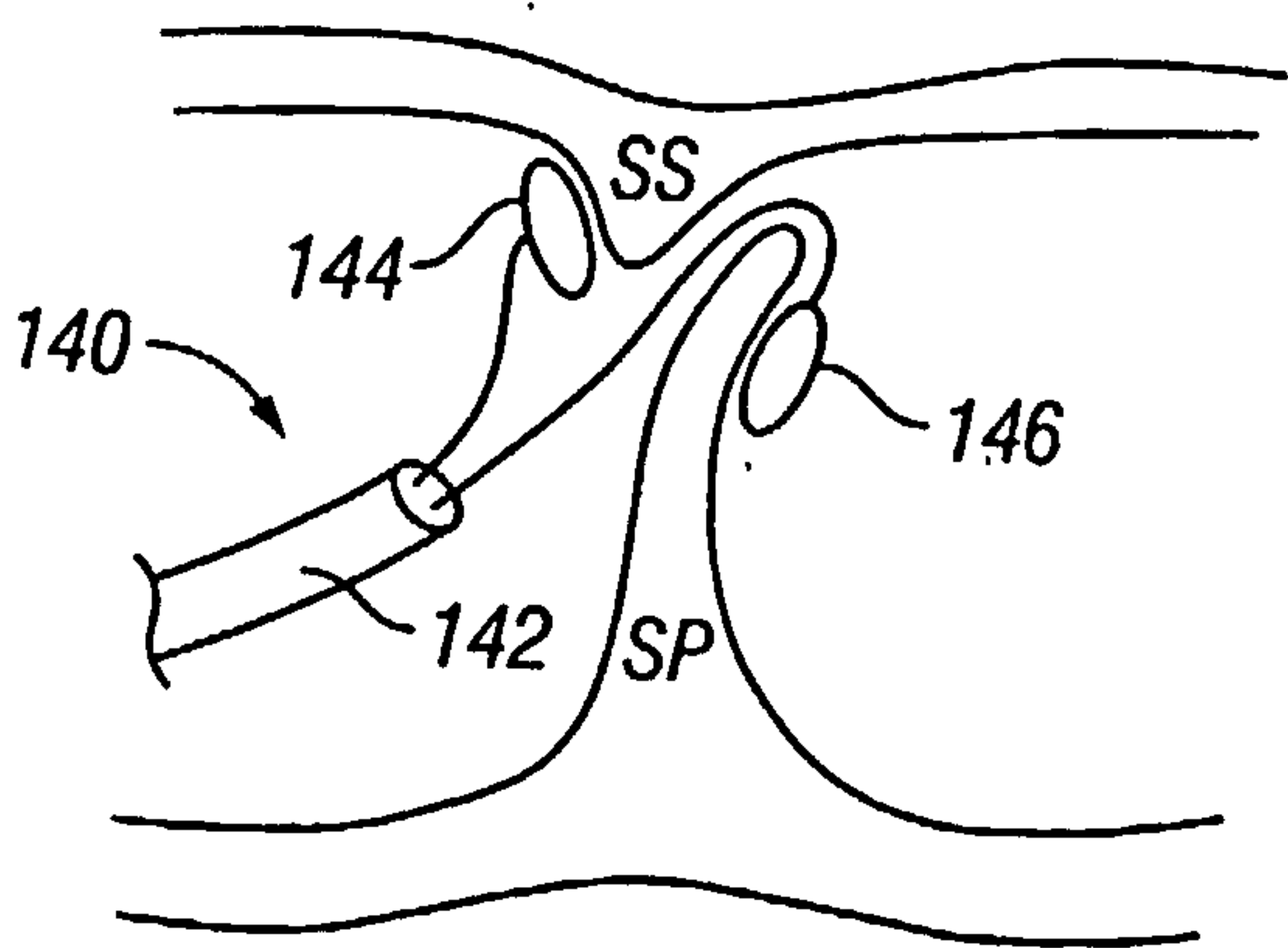

FIG. 15A

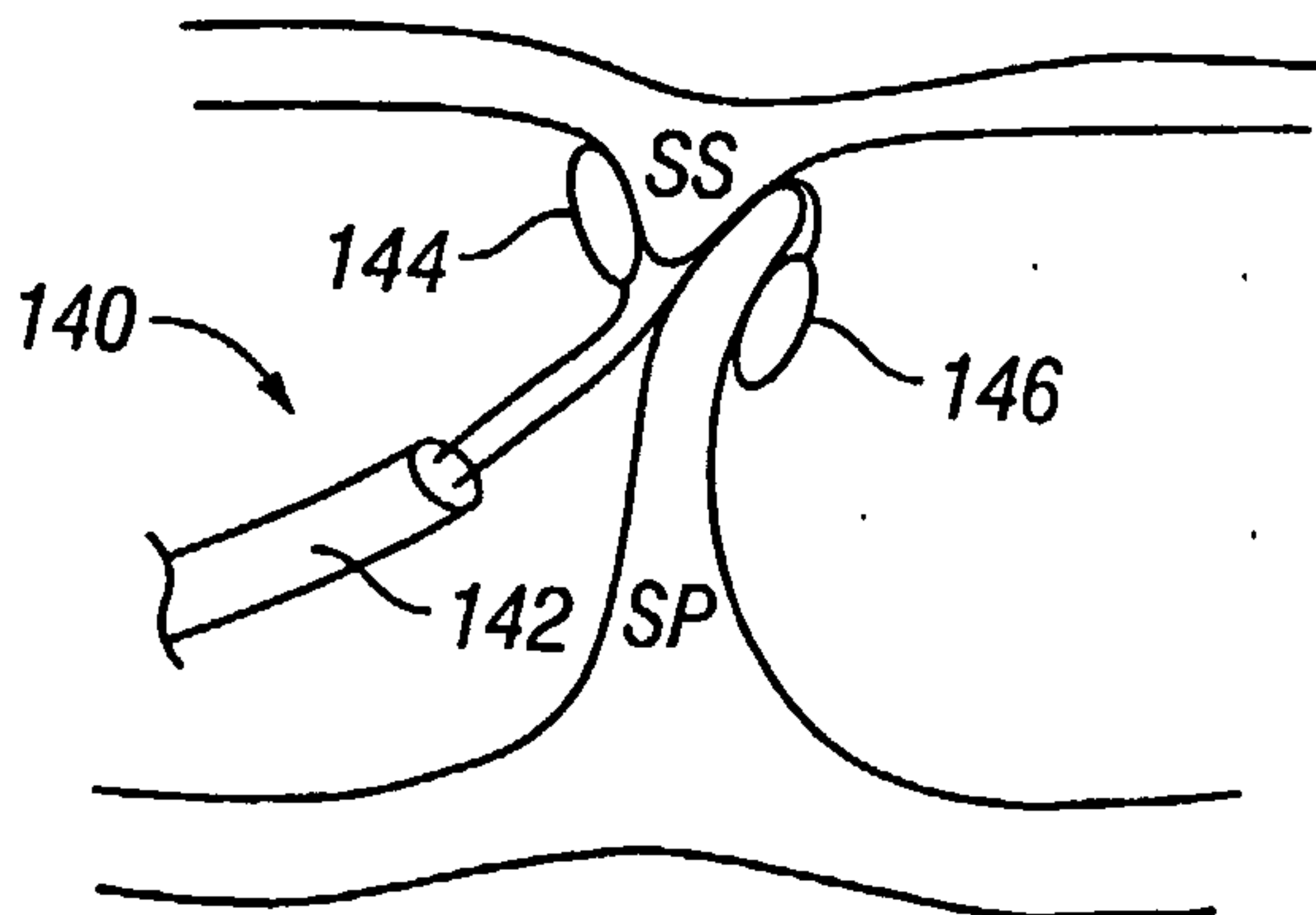

FIG. 15B

12/14

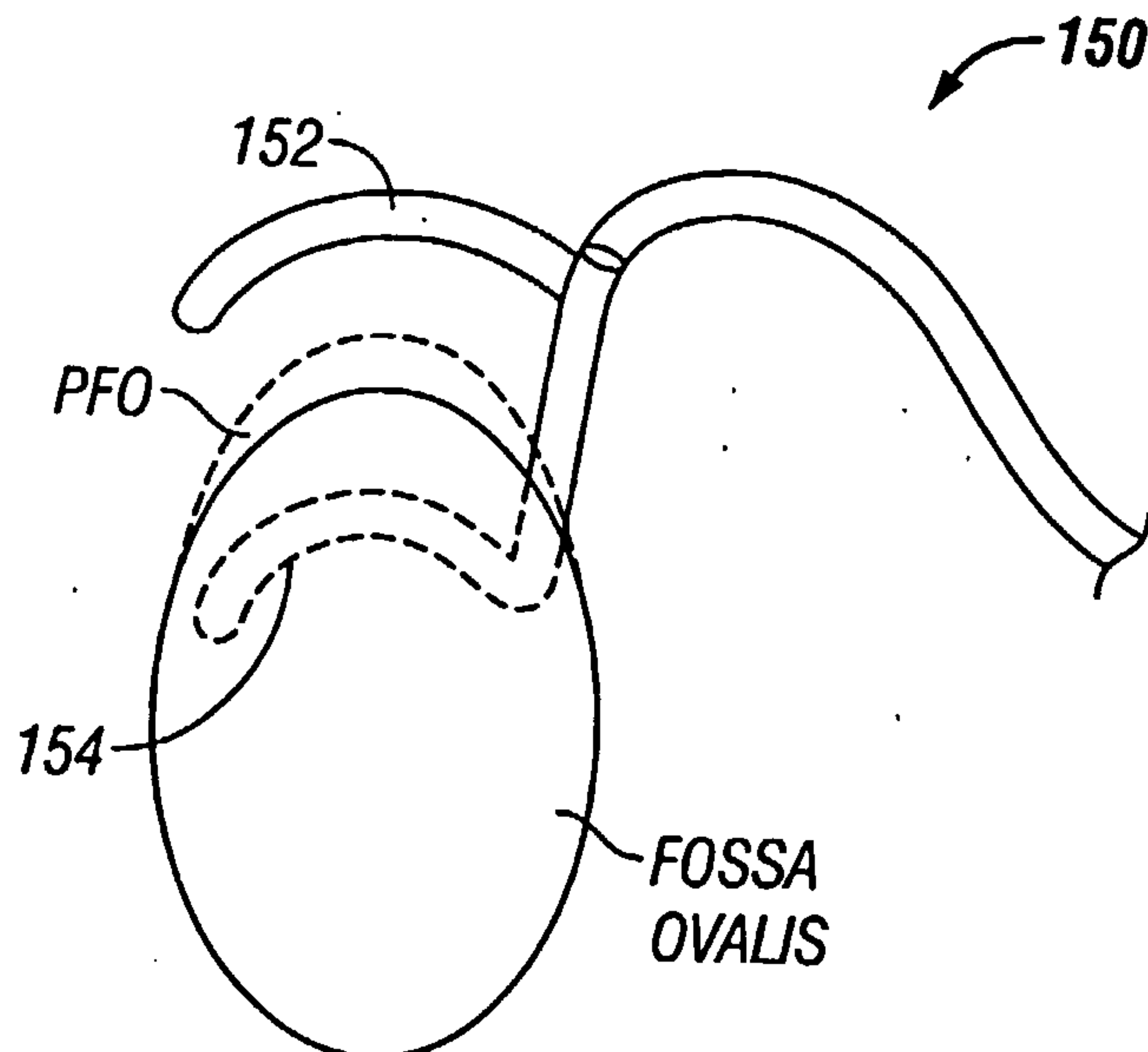

FIG. 17

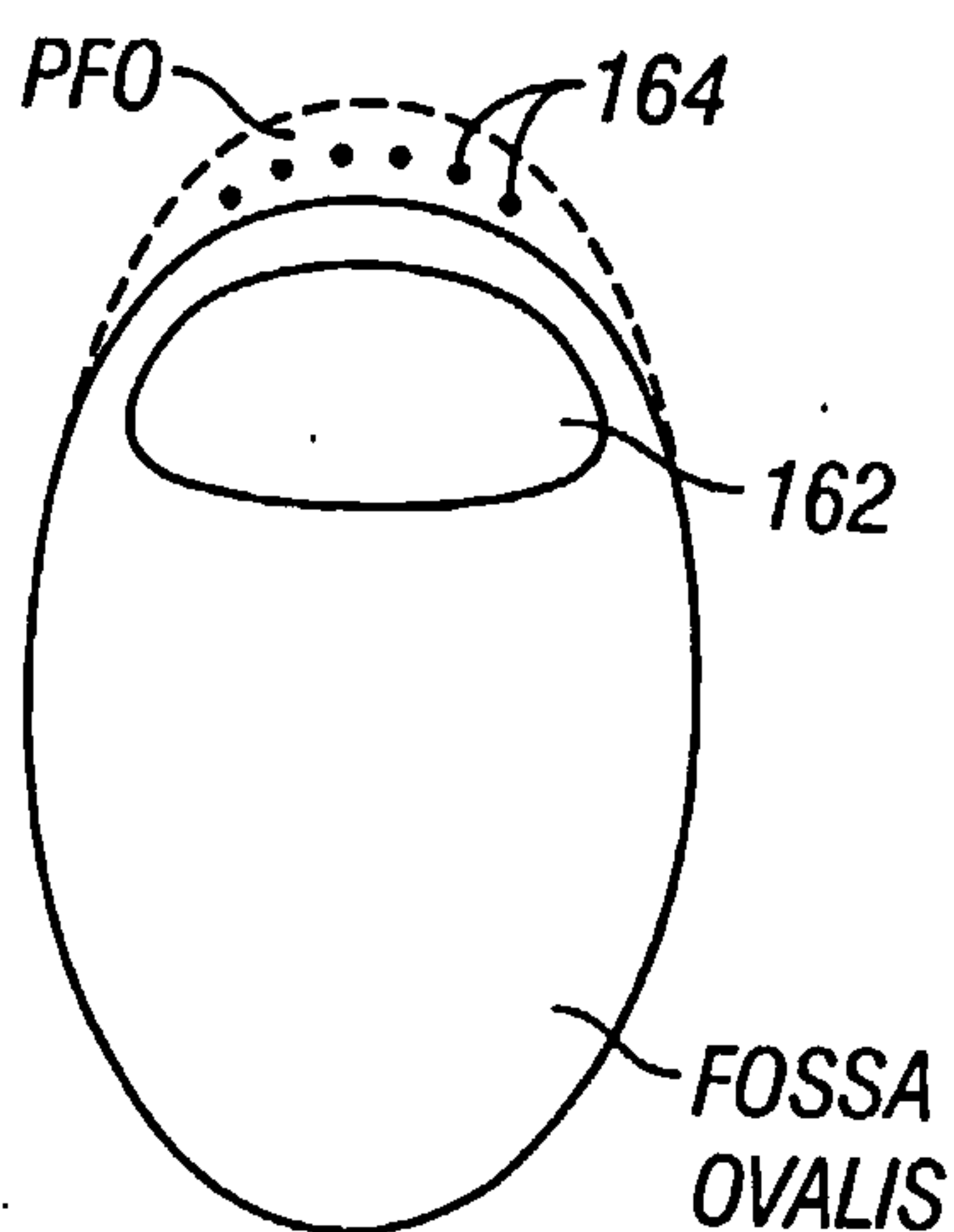

FIG. 18

13/14

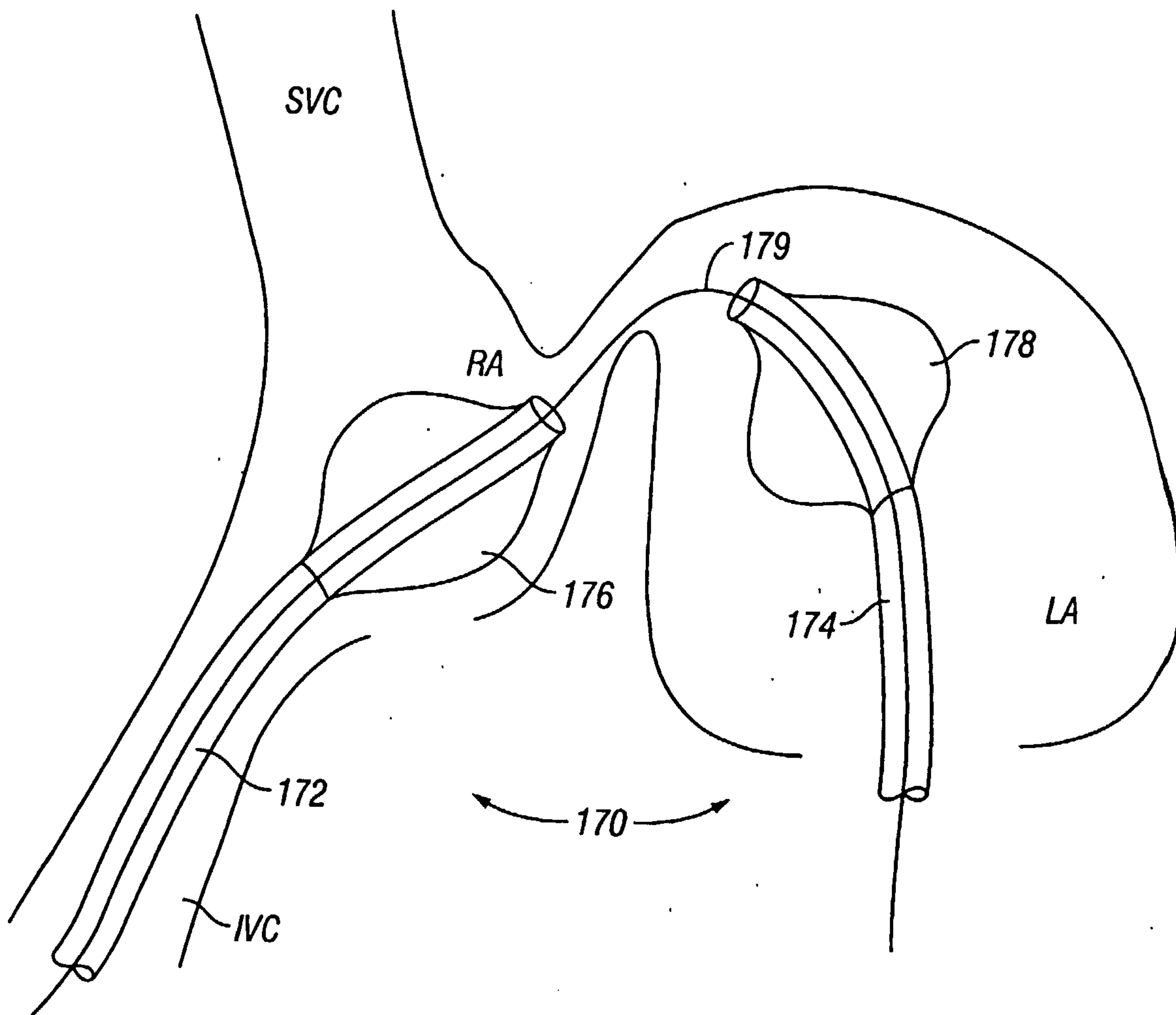

FIG. 19

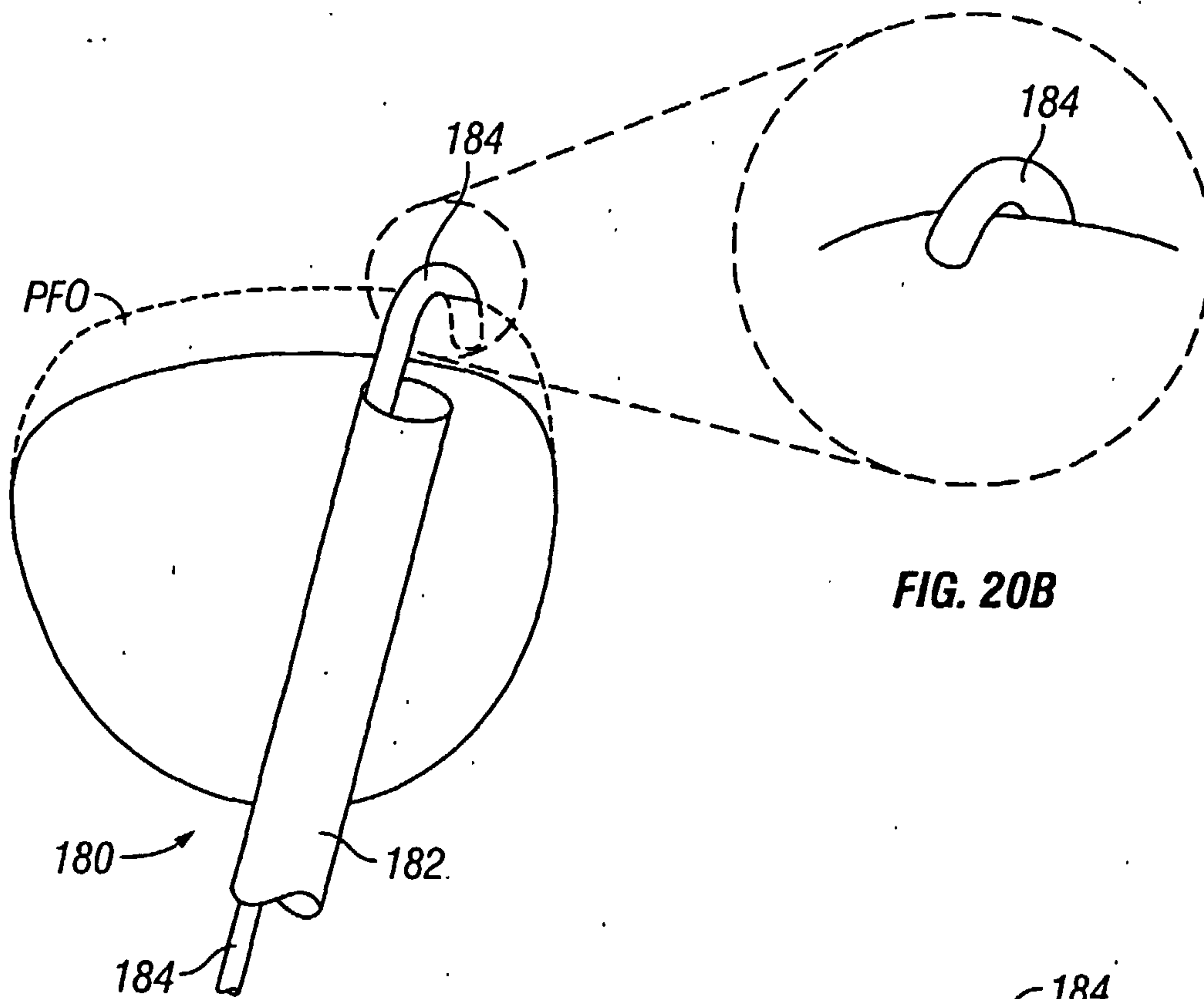

FIG. 20A

FIG. 20B

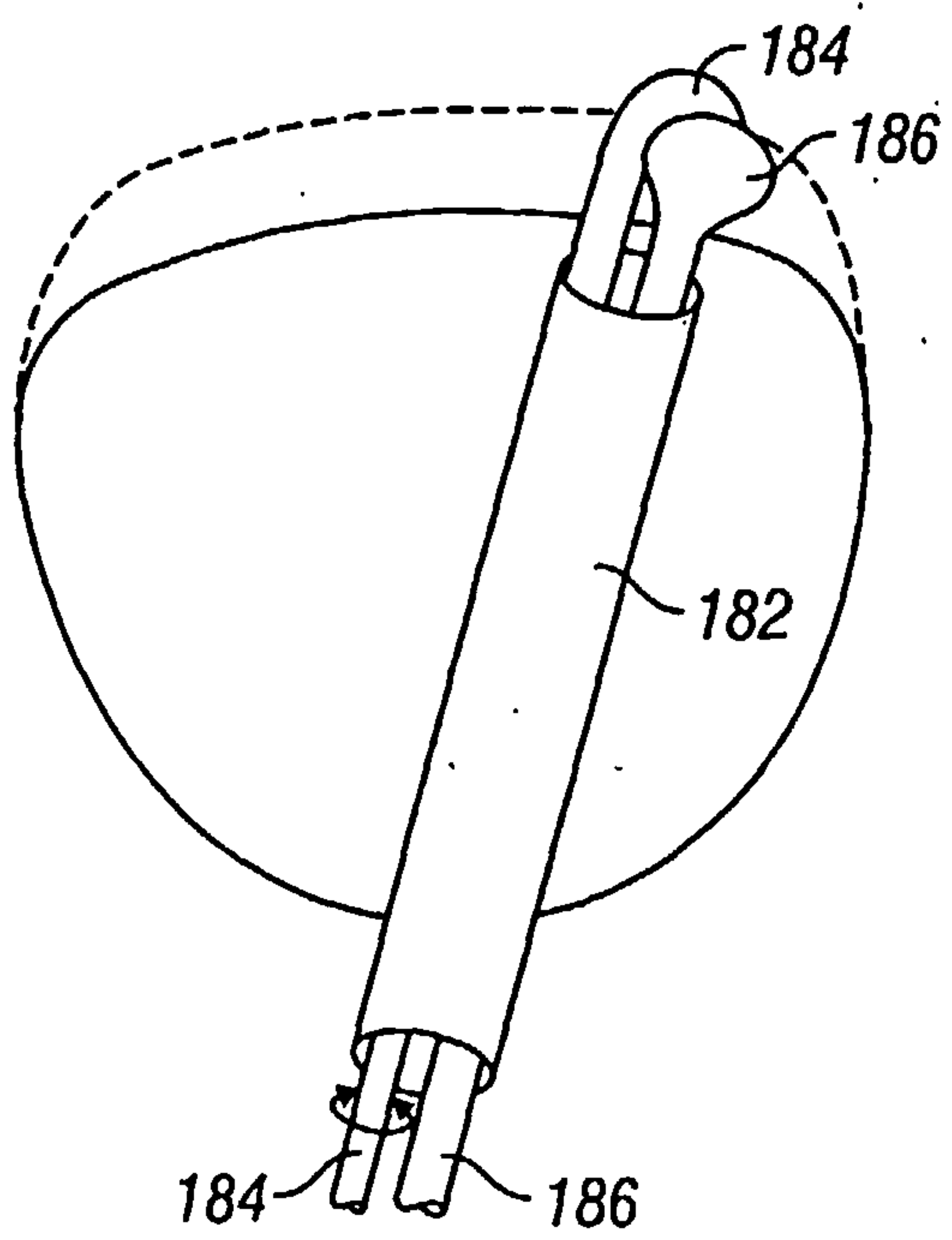

FIG. 20C

