

(12) **UK Patent Application** (19) **GB** (11) **2 279 187** (13) **A**

(43) Date of A Publication 21.12.1994

(21) Application No 9312725.6	(51) INT CL ⁵ H05B 41/29
(22) Date of Filing 19.06.1993	(52) UK CL (Edition M) H2H HB8 HLD61 HLD631 H25G H7B H72
(71) Applicant(s) Thorn Lighting Limited (Incorporated in the United Kingdom) Elstree Way, BOREHAMWOOD, Hertfordshire, WD6 1HZ, United Kingdom	(56) Documents Cited GB 1578038 A GB 1326810 A EP 0065794 A1 WO 90/09729 A1 US 4291254 A US 4245177 A
(72) Inventor(s) James Glenton Kelly	(58) Field of Search UK CL (Edition M) H2H HLD61 HLD631 INT CL ⁵ H05B 41/24 41/26 41/28 41/29
(74) Agent and/or Address for Service Thorn EMI Patents Limited Central Research Laboratories, Dawley Road, Hayes, Middlesex, UB3 1HH, United Kingdom	

(54) **Fluorescent lamp starting and operating circuit**

(57) A resonant start circuit for a discharge lamp includes a resonant combination of capacitance 7 and inductance and is used with an inverter 1, the frequency of operation of which may be varied. Initially at a value at which heater current passes through cathodes 17, 18 of the lamp, the frequency is swept to a value at which the resonant circuit resonates to provide a high voltage to start the lamp 3. In this invention the resonant circuit resonates at an harmonic, preferably the third harmonic, of the frequency of the inverter. In the preferred circuit the lamp cathodes are preheated at 100 to 140 kHz, as the frequency is swept down to 80 kHz the circuit resonates at 240 kHz and the lamp is subsequently run at 50 kHz. A practical circuit has a leakage reactance transformer 13, 14, 15, 16a, 16b connected to provide the cathode heating current and contributing to the inductance of the resonant circuit. The transformer has primary windings 13, 14, 15 which are well coupled to one another, but are not well coupled to the secondary windings 16.

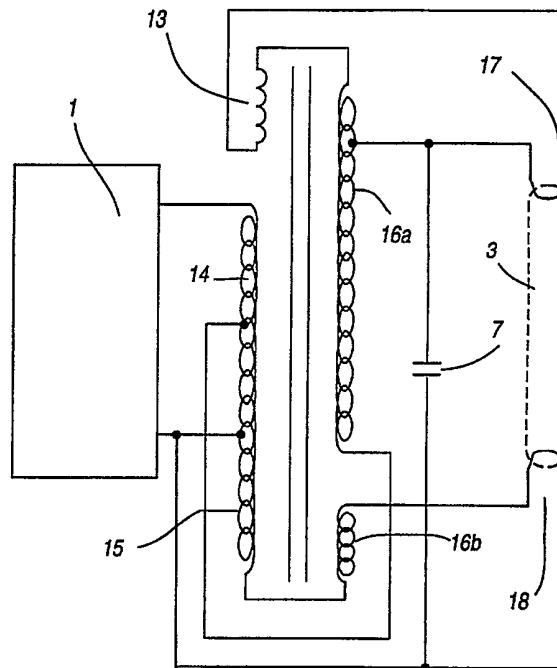

Fig.6.

GB 2 279 187 A

At least one drawing originally filed was informal and the print reproduced here is taken from a later filed formal copy.

The claims were filed later than the filing date within the period prescribed by Rule 25(1) of the Patents Rules 1990.

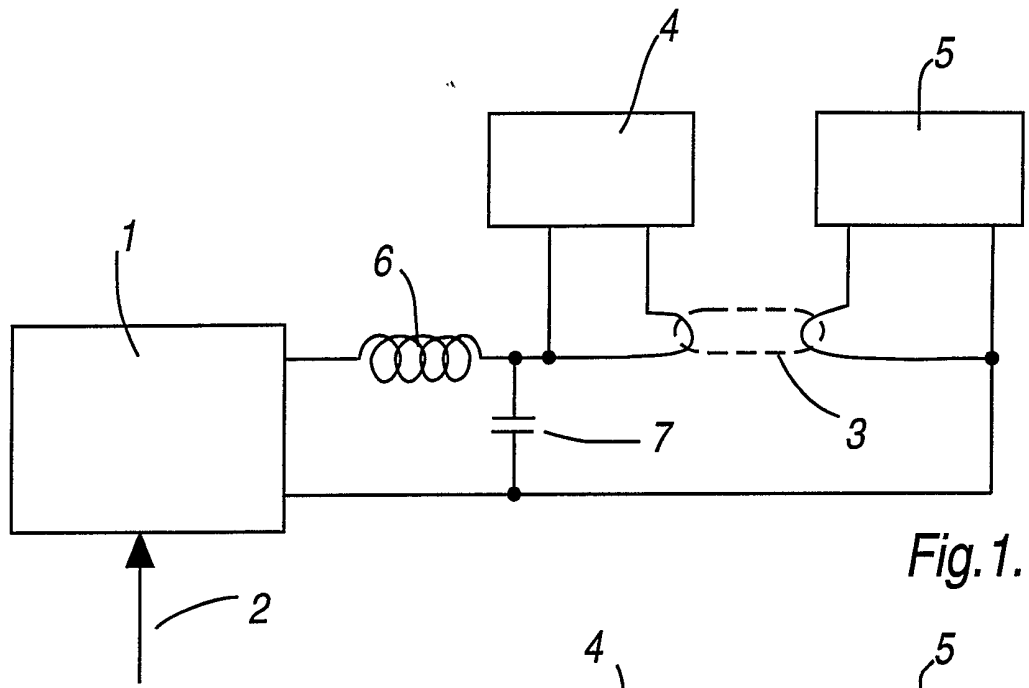

Fig.1.

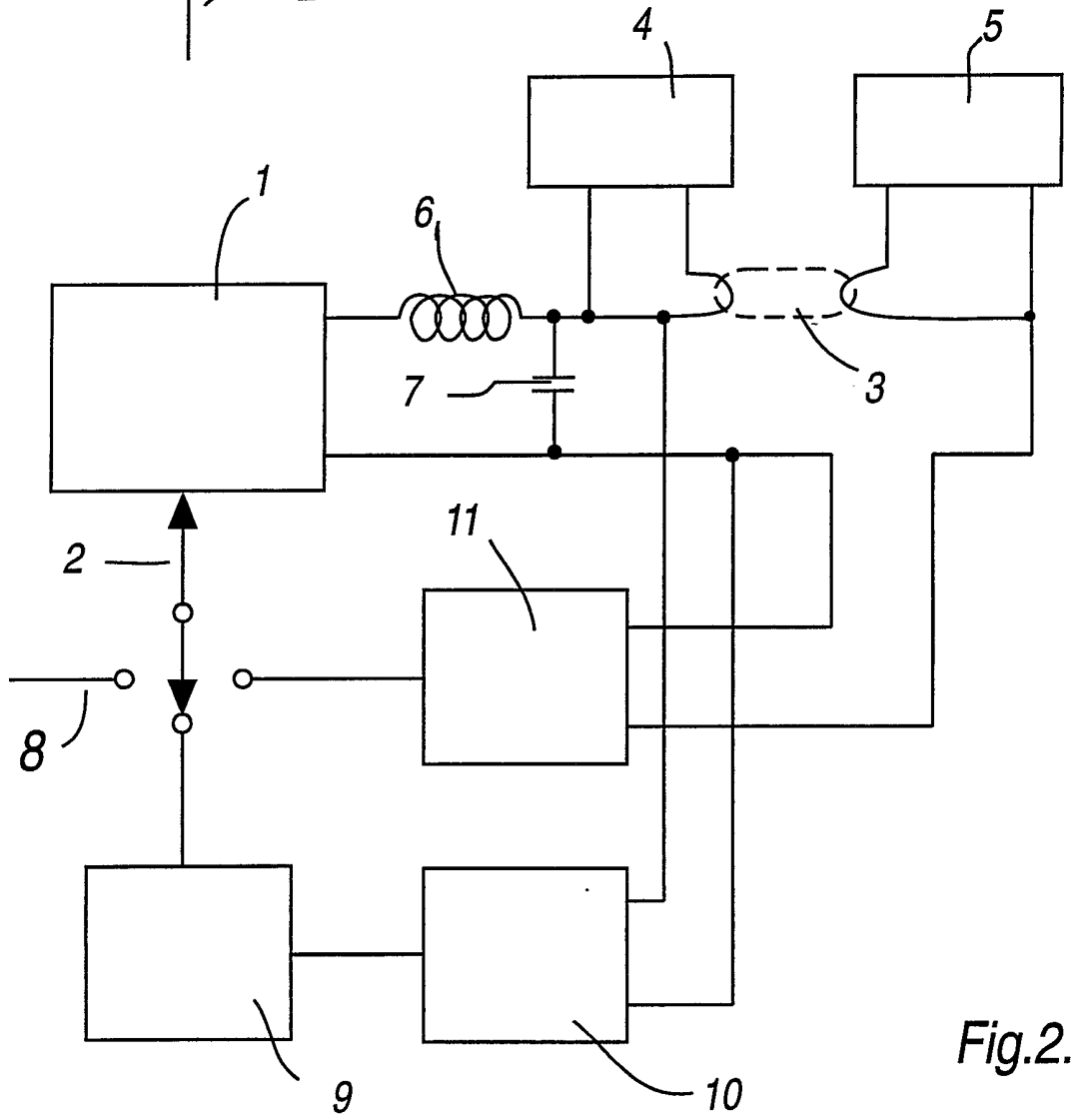

Fig.2.

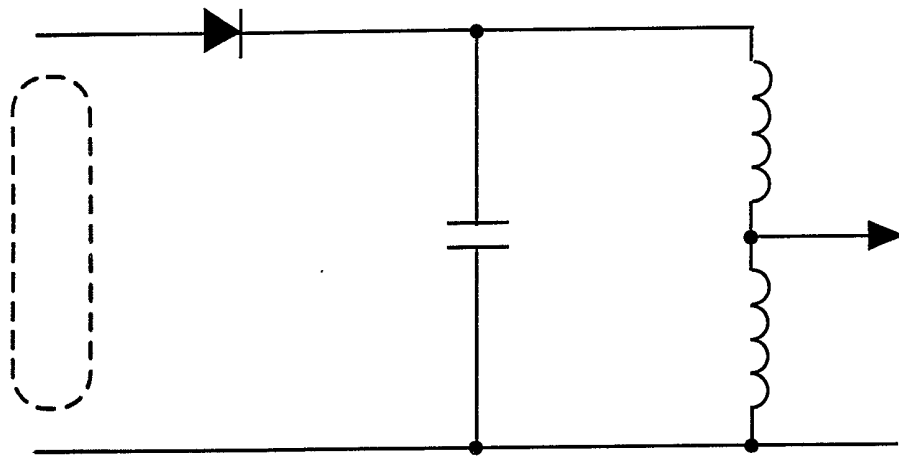

Fig.3a.

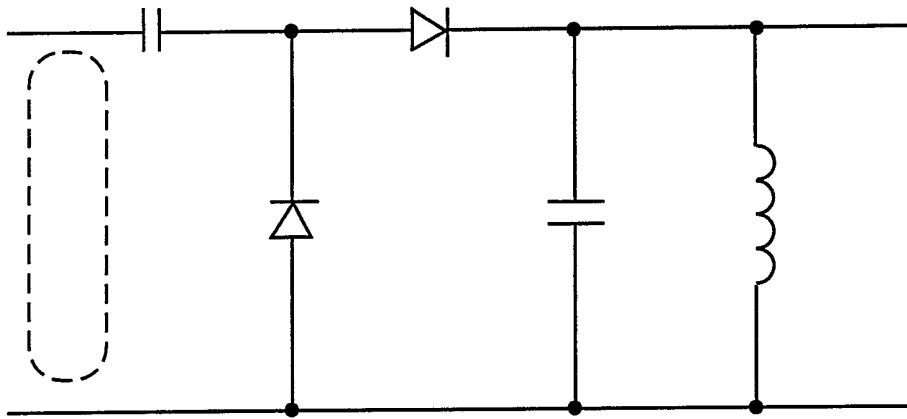

Fig.3b.

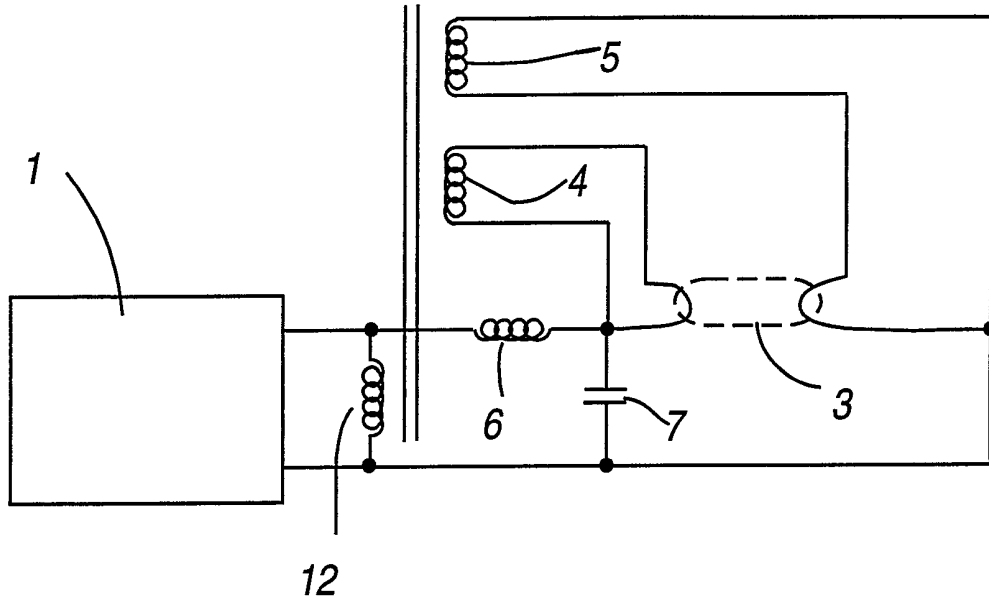

Fig.4a.

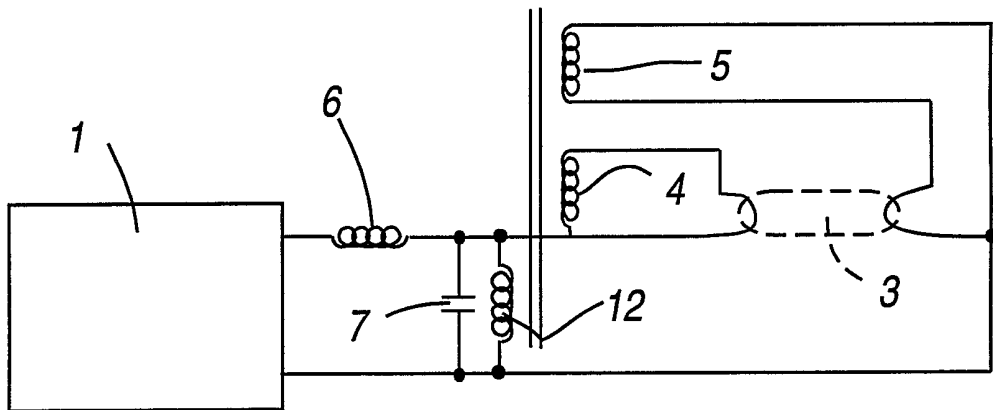

Fig.4b.

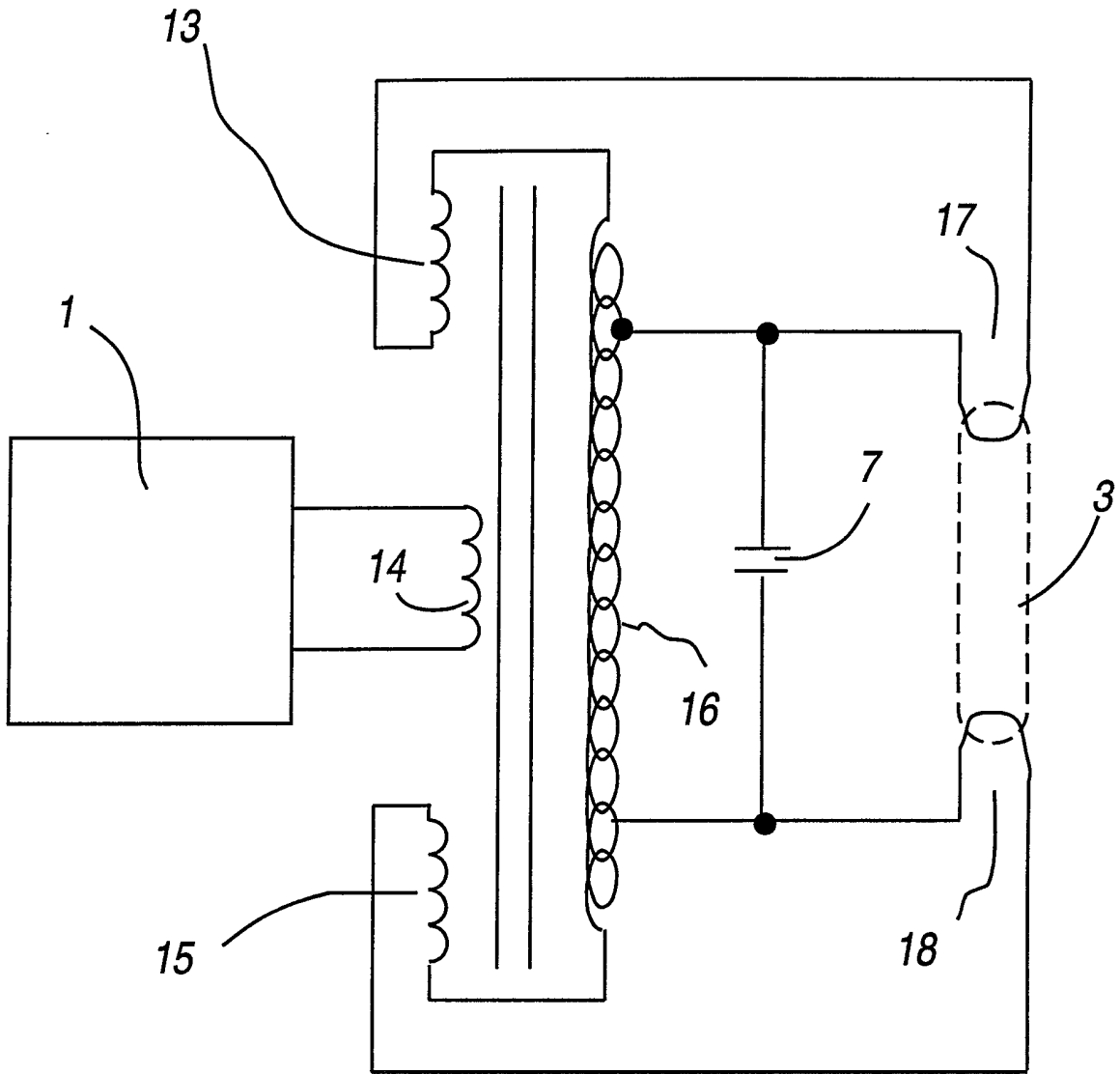

Fig.5.

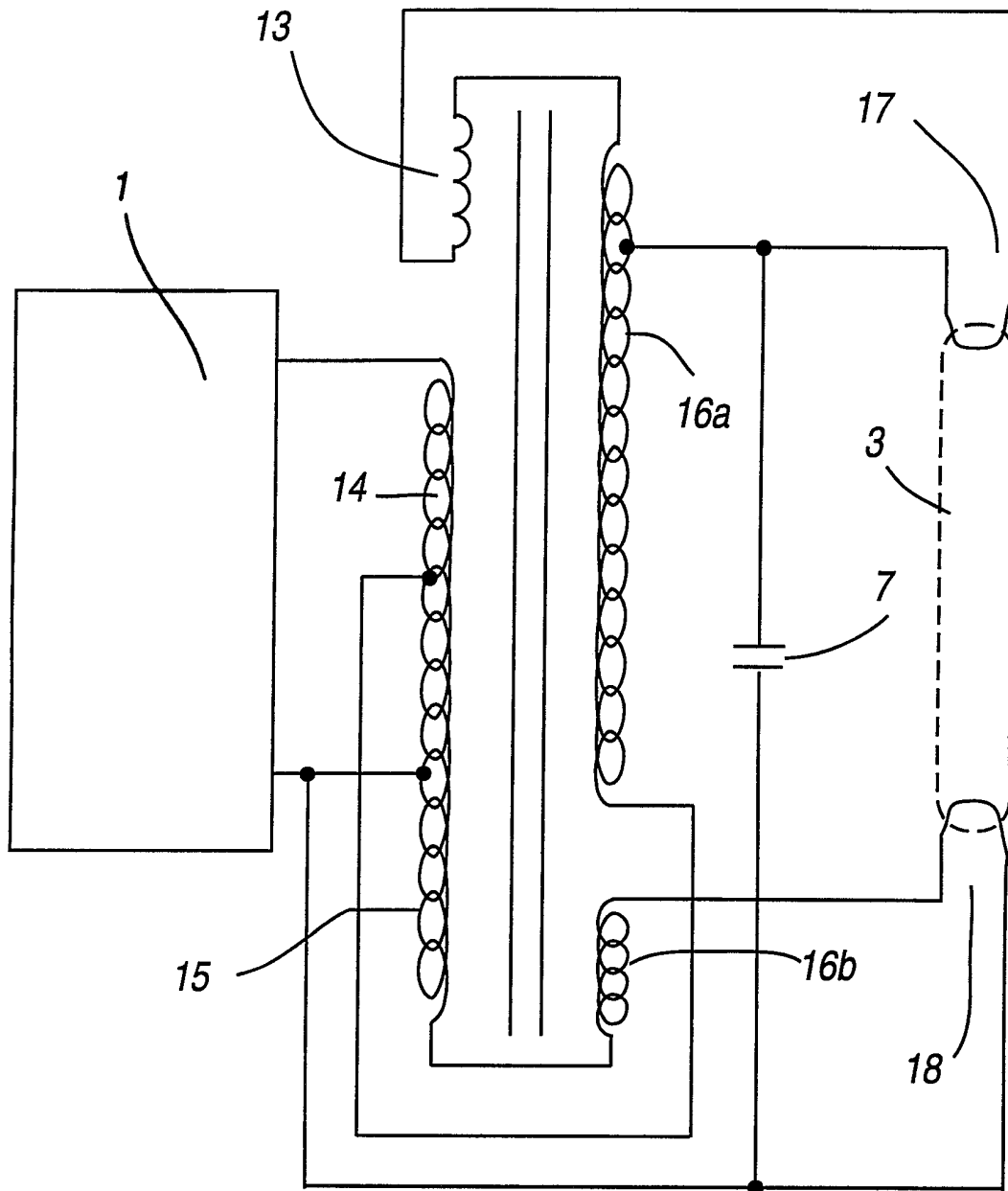

Fig.6.

LAMP STARTER CIRCUIT

The present invention relates to a starter circuit for a discharge lamp and in particular for a low-pressure discharge (fluorescent) lamp.

Fluorescent lamp operating circuits include circuits for initiating a discharge in the gas of the lamp, called starting and for maintaining the discharge when started; running the lamp.

5 The latter function includes a ballast which may be a wire wound ballast of well known type or an electronic ballast which is now becoming more common. Starters, particularly for use with wire wound ballasts, may be separate circuits but may also be incorporated within the circuits of an electronic ballast.

10 For the purpose of starting, a suitably high voltage is applied between the electrodes (cathodes) of the lamp. This may in principle be done with the lamp cold but, in order to avoid damage to the cathodes it is desirable to pass a heater current through them for a suitable period so that the gas in the lamp is ionised more readily when the starting voltage is applied.

15 Several types of starter circuit are well established, for example switch start circuits and electronic start circuits. This invention is concerned with an improvement of the type of starter circuit called resonant start circuits.

20 Such circuits include resonant combinations of capacitance and inductance. The arrangement is such that when the starting sequence is initiated the circuit frequency is not at resonance. Current is at that time passed through the cathodes, heating them for the purpose mentioned above. The circuit sweeps the frequency towards resonance so that by the time the resonant frequency is reached the cathodes have been sufficiently heated. When resonance is reached the voltage across the lamp rises rapidly and is sufficient to start the lamp.

25 With the lamp running and current being carried between the lamp electrodes the electrical characteristics of the circuit are different. The arrangement is such that the circuit then

operates away from resonance. Such circuits are now well established and many examples are known.

In designing an electronic ballast including a starter circuit, many matters need to be considered and the different component circuits interact to some extent.

5 The present invention is particularly suitable for an electronic ballast of the type described in our European Patent Application No 90 303932.9 in which the lamp is driven by a high frequency voltage from an inverter by a charge pump circuit. The circuit may have a series inductor with series tuning and, as described, current flowing in a resonating capacitor across the lamp is used to preheat the cathodes while operating the inverter at high frequency. Reducing the frequency is arranged to result in resonance thus striking the lamp. The ionised lamp damps the resonant circuit.

10 Problems however arise in practice. During preheat the frequency is at its maximum value and the series inductor presents a high impedance which would limit the current at too low a level to heat the cathodes. The value of the inductor cannot be reduced as it determines the value of the ballasting of the lamp in operation. A transformer may thus be required.

15 In a typical circuit preheat is obtained at 120kHz and the frequency is swept down to around 60kHz for resonance to generate the strike voltage. Resonance at 60kHz requires a capacitance of 11nF. With 1000V across the capacitor the peak current would be 4 Amps which is too much to put through the charge pump circuit because it would require too high a rail voltage. Alternatives can be devised but these would result in a reduction of efficiency.

20 According to the invention there is provided a starter circuit for a discharge lamp driven by an inverter operating at a variable frequency in which the circuit is arranged to start the lamp by causing resonance to increase the voltage applied between the lamp cathodes, wherein the circuit is arranged to resonate at an harmonic of the frequency of the inverter.

25 Preferably the circuit resonates at a frequency which is the third harmonic of the frequency of the inverter.

In order that the invention may be understood and readily carried into effect it will now be described with reference to the accompanying drawings of which:

Figure 1 shows a simplified circuit for a ballast including a starter according to the invention;

5 Figure 2 shows a circuit showing in schematic form the control arrangements necessary to operate the invention;

Figure 3 shows two embodiments of the voltage detection circuit for the circuit of Figure 2;

10 Figure 4 shows two arrangements for obtaining cathode heating for the circuit of Figure 2;

Figure 5 shows a more practical cathode heating arrangement;

Figure 6 shows a preferred cathode heating arrangement and

Figure 7 shows a practical ballast circuit incorporating the invention.

15 Using the third harmonic resonance to start the lamp significantly reduces the current required to strike, avoiding overdriving the charge pump. For example 1.8nF resonates at 150kHz (reactance 590 ohms) and 680pF resonates at 240kHz (reactance 976 ohms). In a practical example the inverter has a frequency range of 110kHz to 127.6 kHz, which, with a 10% margin gives 99 to 140kHz. The output circuit can then be resonated between 140kHz and $3 \times 99 = 297$ kHz. This in fact gives two suitable ranges: between 140 and 297
20 kHz (218.5 nominal) and between 420 and 495 kHz (nominal 457.5). For all other values the circuit might resonate in preheat. The circuit should then be tuned at one of the above nominal figures or in practice a little above to allow for added capacitance for example due to lamp leads.

At the higher of the two ranges the charge pump current would be lower but this requires too tight a tolerance and so the lower figure is preferred. It is also preferred that cathode preheat is provided from a separate transformer since if it was derived from the series capacitor as is sometimes the case the electrode current would be insufficient.

5 Looking at the preferred example in more detail then, the operation divides into three parts:

1. Preheating the lamp cathodes at 100 to 140 kHz.
2. Striking the lamp at resonance of 240kHz; and
3. Running the lamp at 50kHz.

10 Figure 1 shows a simplified circuit having at 1 a power source with variable frequency controlled by input 2.

The lamp is shown at 3 and individual power sources shown generally at 4 and 5 provide the cathode preheating. Inductor 6 and capacitor 7 form the resonant circuit. This figure does not indicate how the circuit operation is controlled.

15 The more complex circuit of figure 2 has the frequency control input connected in turn to three control sources to provide the three stages of operation. The preheat input at 8 is a constant voltage which causes the power source 1 to produce a square wave at the appropriate frequency. After a time of about 1 second stage 2 starts and the strike feedback circuit 9 is selected. This controls the voltage across the lamp at a fixed level
20 by way of a voltage detect circuit 10. Other circuits detect when the lamp ionises by monitoring the voltage across the lamp or alternatively monitoring the lamp current. In this example the voltage detect circuit is arranged to do the monitoring. After lamp ionisation is detected stage 3 starts and feedback circuit 11 is selected.

25 The feedback circuit controls the lamp during running in this example by monitoring the lamp current although other examples which will be apparent to those familiar with lamp

running circuits will be apparent. Figure three shows two options for detecting the lamp voltage. The preferred circuit is shown at b). This not only detects the voltage (giving an output proportional to the peak to peak voltage) but the output is additionally proportional to frequency. This can be used readily to detect the resonant condition and helps to avoid the fundamental frequency being swept past the regulating point. This is an issue because of the damping which the cathodes impose on the circuit. Cathode damping is a critical issue with third harmonic starting as the power available to produce resonance is about 10% of the power available for resonant starting at the fundamental frequency.

In Figure 4a there is shown a configuration for the main circuit of Figure 1, deriving cathode heating power from a transformer. The secondaries form the power sources 4 and 5 driven from a primary 12. This configuration does not add to the damping of the resonant circuit and so a high strike voltage should readily be obtained. There is however a disadvantage in that the cathode voltage does not decrease once the lamp is ionised so that unnecessary power is dissipated during normal operation. This is made worse by the fact that in practice the source voltage is greater during stage 3 (run) than during stage 1 (preheat).

In Figure 4b there is therefore shown an alternative in which the cathode heating reduces once the lamp ionises. However the damping which the transformer then places on the resonant circuit greatly reduces the potential strike voltage. For a practical circuit this makes this option unsuitable.

A more practical implementation shown in Figure 5 does not use a separate inductor and transformer but instead uses a leakage reactance transformer. This consists of two windings which are not 100% coupled. Thus if one winding were shorted a voltage could be applied to the other winding without drawing an infinite current. The current can be controlled by adjusting the degree of coupling. Windings 13, 14 and 15 are considered the primary windings and are well coupled to each other while the windings 16 are considered the secondary windings and are well coupled within themselves, but not well coupled to the primary windings.

The lamp cathodes 17 and 18 draw power from both the primary and secondary in a ratio determined by the relative values of N_p and N_s , the primary and secondary turn numbers respectively. This arrangement allows a compromise to be obtained between the damping of the resonance generating the strike voltage and the cathode voltage applied while the ballast runs the lamp.

Figure 6 is equivalent to Figure 5 but is a preferred form. It allows the transformer size to be reduced by substantially reducing the total ampere turns.

Figure 7 shows a complete ballast circuit employing the starting circuit of this invention including a practical implementation of figure 2 and the cathode supply arrangement shown in Figure 6.

other implementations of the principles of this invention will be apparent to those skilled in the art.

CLAIMS

1. A starter circuit, for a discharge lamp driven by an inverter operating at a variable frequency, in which the circuit is arranged to start the lamp by causing resonance to increase the voltage applied between cathodes of the lamp, the circuit including:
a resonant circuit having the lamp connected thereto;
control means arranged to cause the fundamental frequency of the inverter to be swept in use from an initial value, at which preheating current is passed through the lamp cathodes, through a chosen starting value;
the resonant circuit being arranged to resonate substantially at an harmonic of the chosen starting value of the fundamental frequency.
2. A starter circuit according to claim 1 in which the resonant circuit is arranged to resonate substantially at the third harmonic of the said starting value.
3. A starter circuit according to either of the preceding claims in which the control circuit is arranged to cause the frequency of the inverter to maintain a substantially constant frequency at said initial value for a predetermined period for preheat purposes before the frequency is swept to said chosen starting value.
4. A starter circuit according to claim 3 in which the said substantially constant frequency is between 100 and 140 kHz.
5. A starter circuit according to any preceding claim in which the resonant circuit is arranged to resonate at a frequency between 420 and 495 kHz.
6. A starter circuit according to any of claims 1 to 4 in which the resonant circuit is arranged to resonate at a frequency between 140 and 297 kHz.
7. A starter circuit according to claim 6 in which the resonant circuit is arranged to resonate at a nominal frequency of substantially 218.5 kHz.
8. A starter circuit according to claim 6 in which the resonant circuit is arranged to resonate at a nominal frequency of substantially 240 kHz.
9. A starter circuit according to any preceding claim in which the resonant circuit is tuned to a frequency above the frequency at which it is intended to resonate to take into account the effects of stray circuit capacitance.
10. A starter circuit according to any preceding claim including a transformer arranged to provide the cathode heating current.
11. A starter circuit according to claim 10 including a leakage reaction transformer

connection to provide said cathode heating current wherein said leakage reaction transformer provides an inductive component of said resonant circuit.

12. A starter circuit substantially as herein described with reference to the accompanying drawings.

13. In combination an inverter circuit for running a lamp in use and a starter circuit according to any preceding claim.

14. An electronic ballast for operating a discharge lamp, the ballast incorporating a combination according to claim.

15. A method of starting a discharge lamp including the step of:
applying a voltage to the lamp at a first frequency at which cathodes of the lamp are heat; and

sweeping the frequency to a predetermined value to cause a resonant circuit to resonate to increase the voltage across the lamp to a value at which the lamp start wherein the resonant circuit is caused to resonate substantially at an harmonic of the said predetermined frequency value.

16. A method according to claim 15 in which the resonant circuit is caused to resonate substantially at the third harmonic of the said predetermined frequency value.

17. A method of starting a discharge lamp, the method being substantially as herein described with reference to the accompanying drawings.

Relevant Technical Fields

Search Examiner
 M J BILLING

- (i) UK Cl (Ed.M) H2H HLD61, HLD631
 (ii) Int Cl (Ed.5) H05B 4124, 41/26, 41/28, 41/29

Date of completion of Search
 2 AUGUST 1994

Databases (see below)

Documents considered relevant following a search in respect of Claims :-
 1-11, 15, 16

- (i) UK Patent Office collections of GB, EP, WO and US patent specifications.

(ii)

Categories of documents

- | | |
|---|---|
| X: Document indicating lack of novelty or of inventive step. | P: Document published on or after the declared priority date but before the filing date of the present application. |
| Y: Document indicating lack of inventive step if combined with one or more other documents of the same category. | E: Patent document published on or after, but with priority date earlier than, the filing date of the present application. |
| A: Document indicating technological background and/or state of the art. | &: Member of the same patent family; corresponding document. |

Category	Identity of document and relevant passages	Relevant to claim(s)
Y	GB 1578038 (GENERAL ELECTRIC) eg see Figure 4, page 2 lines 17-76	1-3,15,16 at least
Y	GB 1326810 (WAGNER) eg see page 3 lines 17-29	1-3,15,16 at least
Y	EP 0065794 A1 (PHILIPS) eg see Abstract	1-3,15,16 at least
Y	WO 90/09729 A1 (ETTA) eg see page 13 lines 15-36	1-3,15,16 at least
Y	US 4291254 (ARLT) eg see Abstract, column 2 line 15 - column 4 line 16	1-3,15,16 at least
Y	US 4245177 (GENERAL ELECTRIC) eg see column 7 line 60 - column 8 line 66	1-3,15,16 at least

Databases:The UK Patent Office database comprises classified collections of GB, EP, WO and US patent specifications as outlined periodically in the Official Journal (Patents). The on-line databases considered for search are also listed periodically in the Official Journal (Patents).