

(19) World Intellectual Property Organization  
International Bureau



(10) International Publication Number  
**WO 2010/014101 A1**

(43) International Publication Date  
4 February 2010 (04.02.2010)

(51) International Patent Classification:  
*G06F 1/20* (2006.01)     *H05K 7/20* (2006.01)  
*G06F 3/14* (2006.01)     *G06G 7/56* (2006.01)

(74) Agents: **WEBB, Steven** et al.; Hewlett-Packard Company, Legal Department, IP Section, Mail Stop 35, P.O. Box 272400, Fort Collins, CO 80527-2400 (US).

(21) International Application Number:  
PCT/US2008/071789

(81) Designated States (unless otherwise indicated, for every kind of national protection available): AE, AG, AL, AM, AO, AT, AU, AZ, BA, BB, BG, BH, BR, BW, BY, BZ, CA, CH, CN, CO, CR, CU, CZ, DE, DK, DM, DO, DZ, EC, EE, EG, ES, FI, GB, GD, GE, GH, GM, GT, HN, HR, HU, ID, IL, IN, IS, JP, KE, KG, KM, KN, KP, KR, KZ, LA, LC, LK, LR, LS, LT, LU, LY, MA, MD, ME, MG, MK, MN, MW, MX, MY, MZ, NA, NG, NI, NO, NZ, OM, PG, PH, PL, PT, RO, RS, RU, SC, SD, SE, SG, SK, SL, SM, ST, SV, SY, TJ, TM, TN, TR, TT, TZ, UA, UG, US, UZ, VC, VN, ZA, ZM, ZW.

(22) International Filing Date:  
31 July 2008 (31.07.2008)

(25) Filing Language: English

(26) Publication Language: English

(71) Applicant (for all designated States except US): **HEWLETT-PACKARD DEVELOPMENT COMPANY, L.P.** [—/US]; 11445 Compaq Center Drive West, Houston, TX 77070 (US).

(72) Inventors; and

(75) Inventors/Applicants (for US only): **TRACY, Mark, S.** [US/US]; Hewlett-Packard Co., Mail Stop 120602, 20555 Tomball Parkway, Houston, TX 77070 (US). **MOORE, David, A.** [US/US]; Hewlett-Packard Co., (CCA05) CCA5-1 5104, Mail Stop 050103, 11445 Compaq Center Dr W, Houston, TX 77070 (US). **LEV, Jeffrey, A.** [US/US]; Hewlett-Packard Co., Mail Stop CCA120602, 20555 Tomball Parkway, Houston, TX 77070 (US).

(84) Designated States (unless otherwise indicated, for every kind of regional protection available): ARIPO (BW, GH, GM, KE, LS, MW, MZ, NA, SD, SL, SZ, TZ, UG, ZM, ZW), Eurasian (AM, AZ, BY, KG, KZ, MD, RU, TJ, TM), European (AT, BE, BG, CH, CY, CZ, DE, DK, EE, ES, FI, FR, GB, GR, HR, HU, IE, IS, IT, LT, LU, LV, MC, MT, NL, NO, PL, PT, RO, SE, SI, SK, TR), OAPI (BF, BJ, CF, CG, CI, CM, GA, GN, GQ, GW, ML, MR, NE, SN, TD, TG).

**Declarations under Rule 4.17:**

— as to the identity of the inventor (Rule 4.17(i))

[Continued on next page]

(54) Title: COOLING DEVICE FOR COMPUTER DISPLAY

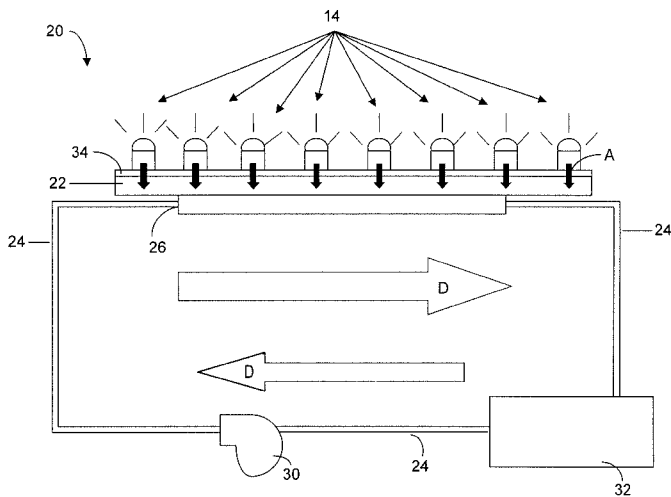
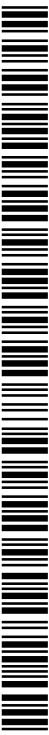

FIG. 2

(57) Abstract: A cooling device for a computer display having a heat generating light source can include a thermal interface material configured to interface with the heat generating light source of a computer display and a liquid coolant passage that is disposed at least one of within and adjacent to the thermal interface material. The liquid coolant passage can be configured to permit flow of a liquid coolant to dissipate heat generated by the heat generating light source.



WO 2010/014101 A1

— *as to applicant's entitlement to apply for and be granted  
a patent (Rule 4.17(ii))*

**Published:**

— *with international search report (Art. 21(3))*

## COOLING DEVICE FOR COMPUTER DISPLAY

### BACKGROUND

[0001] Conventional notebook personal computer (PC) liquid crystal display (LCD) panels have been backlit with cold cathode florescent CCF light emitting bulbs. CCF tubes consume a relatively low amount of power and generate very little thermal energy or heat.

[0002] With the advent of LED backlighting systems for PC LCD panels, an array of over fifty separate LED's can be used to generate acceptable LCD backlighting. However, such super bright white LED's can generate a considerable amount of heat due to their high energy demands in comparison to CCF bulbs. The high heat can degrade and detrimentally affect the longevity of the LED array, thus diminishing the effective brightness of the display.

### SUMMARY

[0003] One embodiment of invention relates to a cooling device for a computer display having a heat generating light source. The cooling device includes a thermal interface material configured to interface with the heat generating light source of the computer display, and a liquid coolant passage, disposed at least one of within and adjacent to the thermal interface material, configured to permit flow of liquid coolant to dissipate heat generated by the heat generating light source.

[0004] Another embodiment of invention relates to a computer with a display that includes a heat generating light source, and a cooling device. The cooling device includes a thermal interface material configured to interface with a heat generating light source and a liquid coolant passage. The liquid coolant passage is disposed at least one of within and adjacent to the thermal interface material. The liquid coolant passage is configured to permit flow of liquid coolant to dissipate heat generated by the heat generating light source.

## BRIEF DESCRIPTION OF THE DRAWINGS

[0005] These and other features, aspects, and advantages of the present disclosure will become apparent from the following description, appended claims, and the accompanying exemplary embodiments shown in the drawings, which are briefly described below.

[0006] FIG. 1 is a perspective view of a computer display.

[0007] FIG. 2 is a schematic side view of a cooling device for a computer display according to an embodiment.

[0008] FIG. 3 is a top view of a back side of a computer display with a cooling device, according to an embodiment.

## DETAILED DESCRIPTION

[0009] Presently preferred embodiments of the invention are illustrated in the drawings. In the drawings, an effort has been made to use like numerals to represent like parts.

[0010] Referring to FIG. 1, an example of a computer display 10 is illustrated. Though a desktop computer display is shown, the display could also be a display of, for example, a notebook or a laptop computer. Computer display 10 can include a liquid crystal display panel (LCD) 12. The LCD can be backlit with at least one heat generating light source 14 (not shown in FIG. 1). For example, a plurality of heat generating light sources 14 can be arranged, such as in a pattern or array, to provide backlighting for the display 10. A display 10, such as the one shown in the example of FIG. 1, can generate a large amount of heat due to the relatively large amount of energy consumed by the display, particularly the heat generating light sources 14 of the display. This heat can degrade components of the display 10, such as the heat generating light sources 14, causing the quality and lifetime of the display 10 to diminish over time.

**[0011]** An exemplary embodiment of a cooling device 20 is illustrated in the examples of FIGS. 2 - 3. Such a cooling device 20 can be used to extend the lifetime of a display 10, such as by minimizing the degradation of the display 10 that is caused by elevated temperatures created by power consumption by a heat generating light source 14. The heat generating light source 14 can be, for example, an LED. The heat generating light source 14 can be mounted on a printed circuit board (PCB) 34 that is located within a computer display 10, as shown in the example of FIG. 2. A cooling device 20 for a heat generating light source 14 of a display can include a thermal interface material (TIM) 22 and a coolant passage 24. The example of FIG. 2 shows a plurality of heat generating light sources 14 that can be used to backlight a display 10.

**[0012]** The TIM 22 can be configured to interface with a heat generating light source 14 of a computer display 10 in order to conduct heat from the heat generating light source 14, as indicated by the arrows A in the example of FIG. 2. The heat generated by the light source 14 can also be transferred through the PCB 34 to the TIM 22.

**[0013]** The TIM 22 can be made of, for example, a material with a relatively high thermal conductivity. Furthermore, the TIM 22 can be electrically insulative so that TIM 22 does not conduct electricity from the heat generating light source 14 and/or the PCB 34. The TIM 22 can be made of a material that conforms to the internal surfaces of computer display 10. For example, the TIM 22 can be arranged so that no gap, such as an air gap, exists between TIM 22 and the heat generating light source 14 or the PCB 34 in order to efficiently heat transfer from the heat generating light source 14. The TIM 22 can be, for example, an elastomeric thermal interface material. Examples of materials that can be used as the TIM 22 include Loctite® Thermostrate® 2000 manufactured by Henkel Corporation, Shin-Etsu 77XX Series grease manufactured by Shin-Etsu Chemical Co., Ltd, Denka FSL-B manufactured by Denka Corporation, Thermagon TIM products manufactured by Laird Technologies, or Gap-Pad® or Hi-Flow® products manufactured by the Bergquist Company.

[0014] As shown in the examples of FIGS. 2 - 3, the coolant passage 24 can be arranged so that the coolant passage 24 is disposed at least one of within and/or adjacent to the TIM 22. The coolant passage 24 can be configured to permit flow of a coolant through the coolant passage 24 so as to dissipate heat generated by a heat generating light source 14. As shown in the example of FIG. 3, the coolant passage 24 can be arranged to maximize the surface area of the coolant passage 24 that is within and/or adjacent to the TIM 22. For example, the coolant passage 24 can be arranged in a snaking configuration, a zig-zag configuration, coil-like configuration, or other configuration used in the art.

[0015] A portion of coolant passage 24 can be enclosed by a pipe or tube 26 to further aid in the dissipation of heat generated by the heat generating light source 14. For example, the pipe 26 can be arranged to be within and/or adjacent to the TIM 22, as shown in the example of FIG. 2. Furthermore, the pipe 26 can be configured to encase at least a portion of the coolant passage 24, as shown in the example of FIG. 2. The pipe 26 can be made of a material with a relatively high thermal conductivity, such as, for example, copper.

[0016] The coolant can be, for example, a fluid, such as a liquid. An example of a liquid coolant is a water based mixture, such as a mixture of propylene glycol and water. A particular example of such a mixture is Showbrine SLP-F manufactured by Showa Water Industries Co., Ltd.

[0017] The cooling device 20 can include a pump 30 that is configured to circulate coolant through the coolant passage 24. For example, the pump 30 can be configured to circulate the coolant through the coolant passage 24 in the direction indicated by arrows D in FIG. 2.

[0018] The cooling device 20 can include a heat exchanger 32 to remove heat absorbed from the TIM 22 by coolant in the coolant passage 24. The heat exchanger 32 can be, for example, an evaporator or other type of heat exchanger used in the art. The heat exchanger 32 can be naturally air cooled, forced air cooled, liquid cooled, or any combination thereof. The pump 30 and heat exchanger 32, when present in a

cooling device 20, can be located inside of the interior of a display 10 or outside of the interior of a display, as in the example of FIG. 3.

**[0019]** The cooling device 20 can also be configured to dissipate heat generated by other components contained within a computer, such as, for example, a central processing unit (CPU), a graphics processing unit (GPU), or other computer component. For example, FIG. 2 shows that a CPU 36 or a GPU 36 can be cooled by the cooling device 20. Such components may have previously had their own dedicated cooling system but the use of the cooling device 20 to cool other components in addition to the display 10 of a computer can provide efficient cooling of the display and computer components without the use of redundant cooling systems, additional parts, and additional cost.

**[0020]** The cooling device 20 can be used in various computer configurations that include a display utilizing a heat generating light source 14, such as, for example, notebook PC's, desktop computers, desktop gaming systems or gaming notebook computers, network terminals, or other computers with backlit displays.

**[0021]** The foregoing description of embodiments of the invention has been presented for purposes of illustration and description. It is not intended to be exhaustive or to limit the invention to the precise form disclosed, and modifications and variations are possible in light of the above teachings or may be acquired from practice of the invention. The embodiments were chosen and described in order to explain the principals of the invention and its practical application to enable one skilled in the art to utilize the invention in various embodiments and with various modifications as are suited to the particular use contemplated. Other embodiments of the invention will be apparent to those skilled in the art from consideration of the specification and practice of the invention disclosed herein.

**WHAT IS CLAIMED IS:**

1. A cooling device for a computer display having a heat generating light source, comprising:
  - a thermal interface material configured to interface with the heat generating light source of the computer display;
  - a liquid coolant passage, wherein the liquid coolant passage is disposed at least one of within and adjacent to the thermal interface material, wherein the liquid coolant passage is configured to permit flow of liquid coolant to dissipate heat generated by the heat generating light source.
2. The cooling device of claim 1, wherein the heat generating light source includes a plurality of LEDs.
3. The cooling device of claim 1, wherein the thermal interface material includes an elastomeric material.
4. The cooling device of claim 1, wherein the liquid coolant includes a water based mixture.
5. The cooling device of claim 1, further comprising a pipe that encases at least a portion of the liquid coolant passage.
6. The cooling device of claim 1, further comprising a pump configured to pump the liquid coolant through at least the liquid coolant passage.
7. The cooling device of claim 1, wherein the cooling device is further configured to dissipate heat generated by a central processing unit.
8. The cooling device of claim 1, wherein the cooling device is further configured to dissipate heat generated by a graphics processing unit.
9. A computer, comprising:
  - a display that includes a heat generating light source;
  - a cooling device, comprising:

a thermal interface material configured to interface with the heat generating light source;

a liquid coolant passage, wherein the liquid coolant passage is disposed at least one of within and adjacent to the thermal interface material, wherein the liquid coolant passage is configured to permit flow of liquid coolant to dissipate heat generated by the heat generating light source.

10. The computer of claim 9, wherein the heat generating light source includes a plurality of LEDs.

11. The computer of claim 9, wherein the thermal interface material includes an elastomeric material.

12. The computer of claim 9, wherein the cooling device further comprises a pipe that encases at least a portion of the liquid coolant passage.

13. The computer of claim 9, wherein the cooling device further comprises a pump configured to pump the liquid coolant through at least the liquid coolant passage.

14. The computer of claim 9, further comprising a central processing unit, wherein the cooling device is further configured to dissipate heat generated by the central processing unit.

15. The computer of claim 9, further comprising a graphics processing unit, wherein the cooling device is further configured to dissipate heat generated by the graphics processing unit.

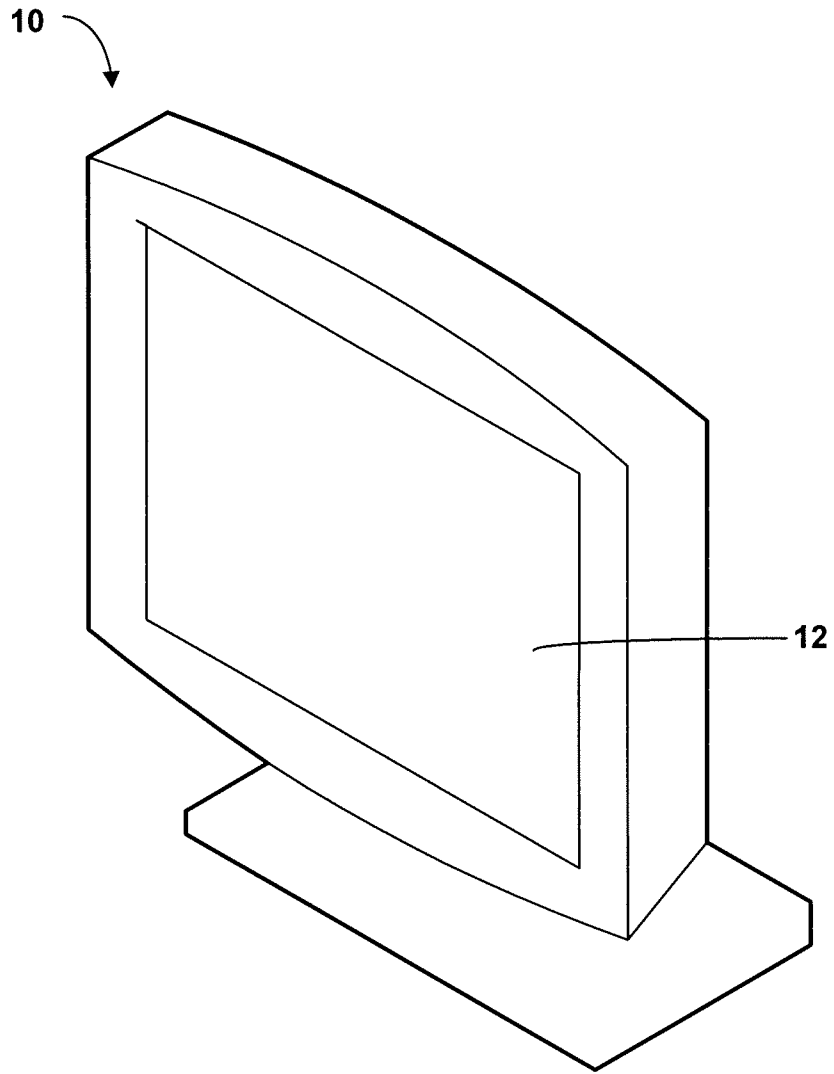

FIG. 1

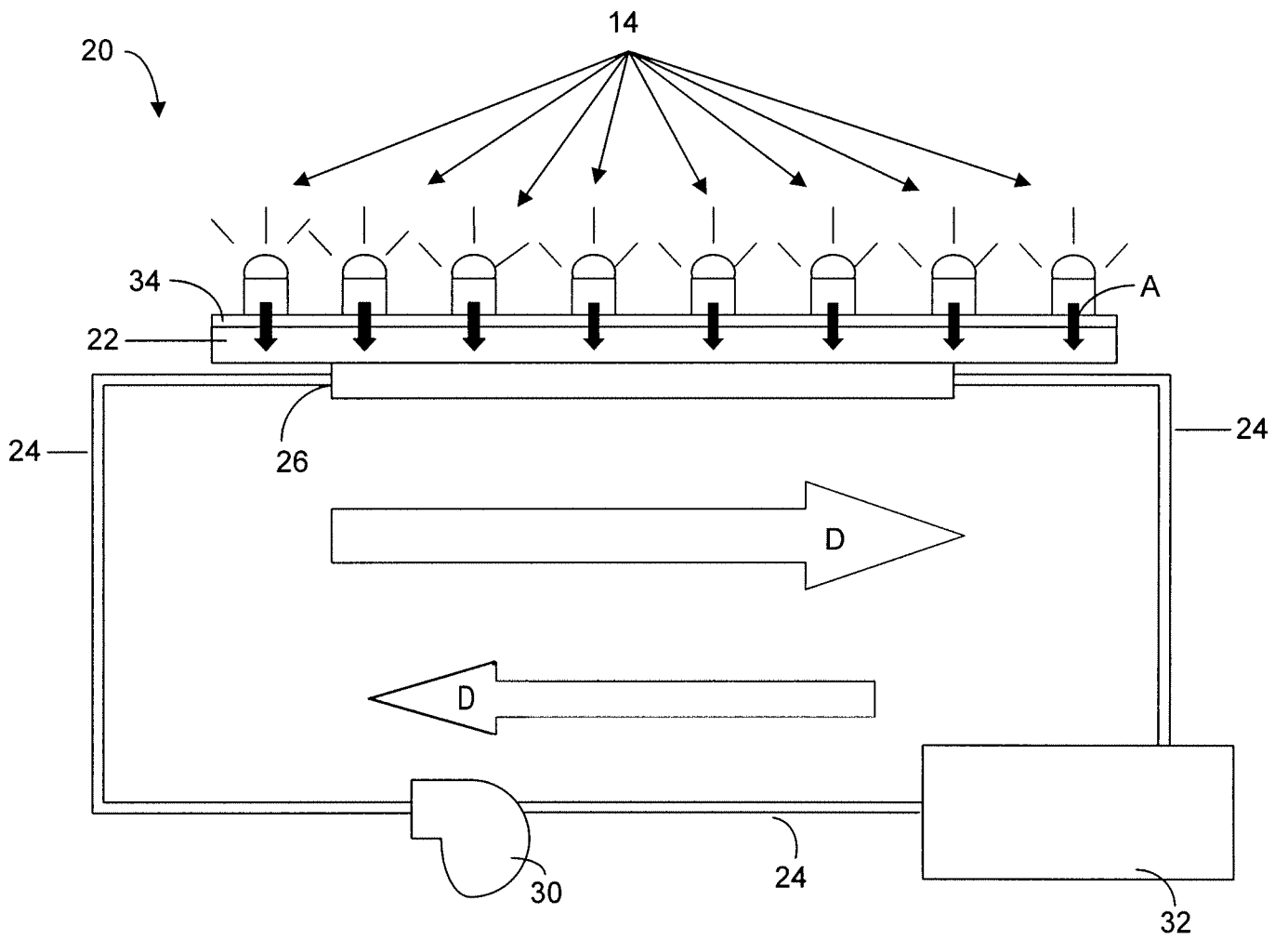

FIG. 2

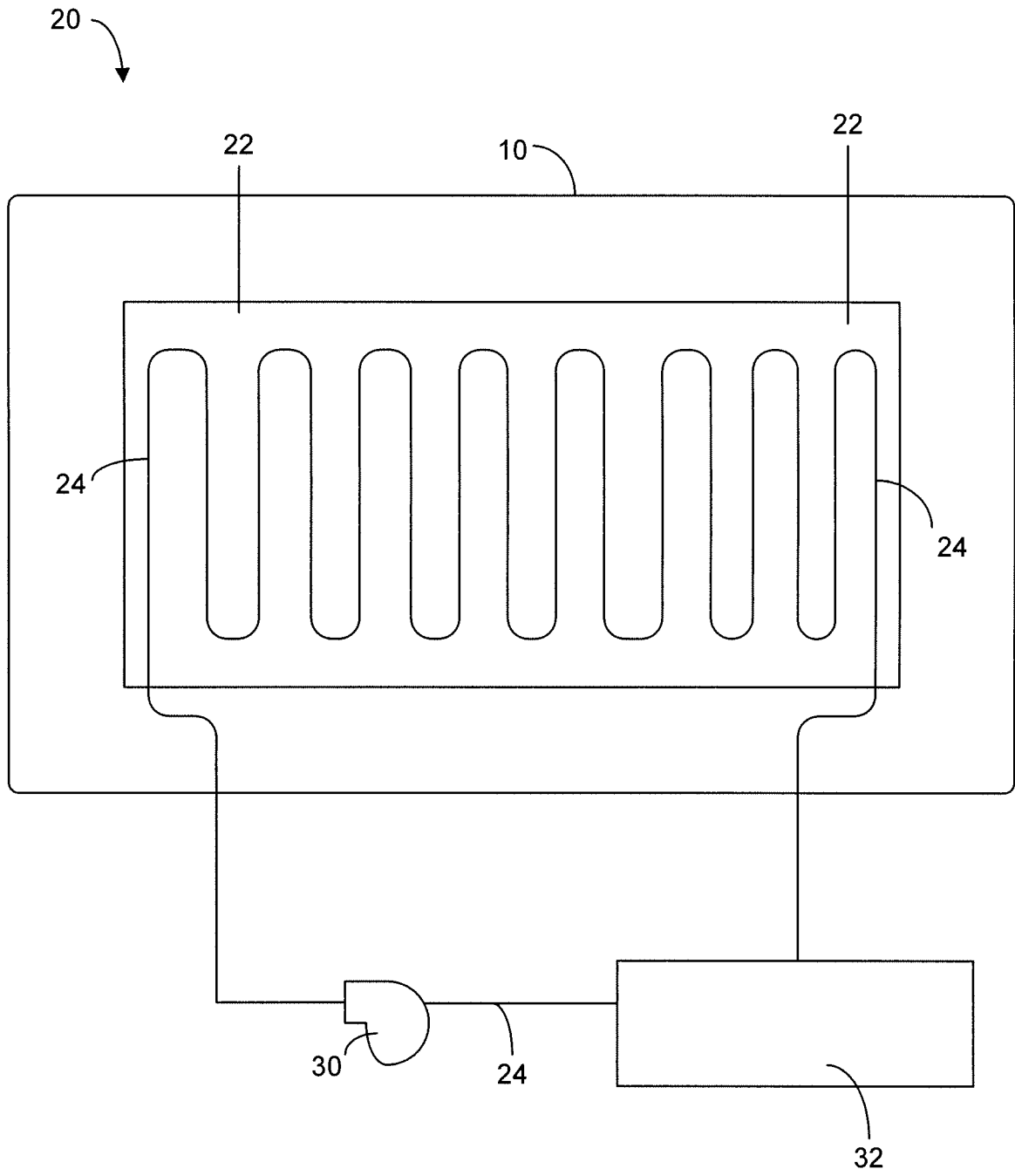

FIG. 3

**A. CLASSIFICATION OF SUBJECT MATTER****G06F 1/20(2006.01)i, G06F 3/14(2006.01)i, H05K 7/20(2006.01)i, G06G 7/56(2006.01)i**

According to International Patent Classification (IPC) or to both national classification and IPC

**B. FIELDS SEARCHED**

Minimum documentation searched (classification system followed by classification symbols)

IPC G06F, H05K, G02F

Documentation searched other than minimum documentation to the extent that such documents are included in the fields searched

Korean Utility models and applications for Utility models since 1975

Japanese Utility models and applications for Utility models since 1975

Electronic data base consulted during the international search (name of data base and, where practicable, search terms used)

eKIPASS(KIPO internal) "Keywords: display device, coolant and similar terms"

**C. DOCUMENTS CONSIDERED TO BE RELEVANT**

Category*	Citation of document, with indication, where appropriate, of the relevant passages	Relevant to claim No.
X	US 2004-0196628 A1 (KATSUMI HISANO et al.) 07 October 2004 See the abstract, paragraphs [0026-0033, 0041-0042, 0045], Claims, and figures 1, 4-6.	1-15
A	US 2002-0109969 A1 (STEFAN WELLHOFER) 15 August 2002 See the abstract, paragraphs [0006, 0008, 0022, 0027], Claims, and figure 1.	1-15
A	US 5502582 A (RALPH I. LARSON et al.) 26 March 1996 See the abstract, column 2, line 17 - line 44, column 4, line 12 - line 63, Claims, and figures 1-2.	1-15
A	KR 10-2007-0054001 A (DAEWOO ELECTRONICS CORP.) 28 May 2007 See the abstract, figures 2-3, and related explanations.	1-15

 Further documents are listed in the continuation of Box C. See patent family annex.

\* Special categories of cited documents:

"A" document defining the general state of the art which is not considered to be of particular relevance

"E" earlier application or patent but published on or after the international filing date

"L" document which may throw doubts on priority claim(s) or which is cited to establish the publication date of citation or other special reason (as specified)

"O" document referring to an oral disclosure, use, exhibition or other means

"P" document published prior to the international filing date but later than the priority date claimed

"T" later document published after the international filing date or priority date and not in conflict with the application but cited to understand the principle or theory underlying the invention

"X" document of particular relevance; the claimed invention cannot be considered novel or cannot be considered to involve an inventive step when the document is taken alone

"Y" document of particular relevance; the claimed invention cannot be considered to involve an inventive step when the document is combined with one or more other such documents, such combination being obvious to a person skilled in the art

"&amp;" document member of the same patent family

Date of the actual completion of the international search

29 MAY 2009 (29.05.2009)

Date of mailing of the international search report

**29 MAY 2009 (29.05.2009)**

Name and mailing address of the ISA/KR

Korean Intellectual Property Office  
Government Complex-Daejeon, 139 Seonsa-ro, Seo-gu, Daejeon 302-701, Republic of Korea

Facsimile No. 82-42-472-7140

Authorized officer

HWANG, Yun Koo

Telephone No. 82-42-481-5788



**INTERNATIONAL SEARCH REPORT**

Information on patent family members

International application No.

**PCT/US2008/071789**

Patent document cited in search report	Publication date	Patent family member(s)	Publication date
US 2004-0196628 A1	07.10.2004	CN 1525810 A	01.09.2004
		EP 1443813 A2	04.08.2004
		JP 2004-233791 A	19.08.2004
US 2002-0109969 A1	15.08.2002	AT 247323 T	15.08.2003
		DE 50100493 D1	18.09.2003
		DK 1231588 T3	01.12.2003
		EP 1231588 A1	14.08.2002
		EP 1231588 B1	13.08.2003
		ES 2204767 T3	01.05.2004
		JP 2002-314900 A	25.10.2002
		JP 3800327 B2	26.07.2006
		US 6714410 B2	30.03.2004
		US 5502582 A	26.03.1996
DE 69519233 D1	30.11.2000		
DE 69519233 T2	05.04.2001		
EP 0778931 A1	18.06.1997		
EP 0778931 B1	25.10.2000		
JP 10-505195 T	19.05.1998		
JP 3257798 B2	18.02.2002		
WO 96-07854 A1	14.03.1996		
KR 10-2007-0054001 A	28.05.2007	None	