

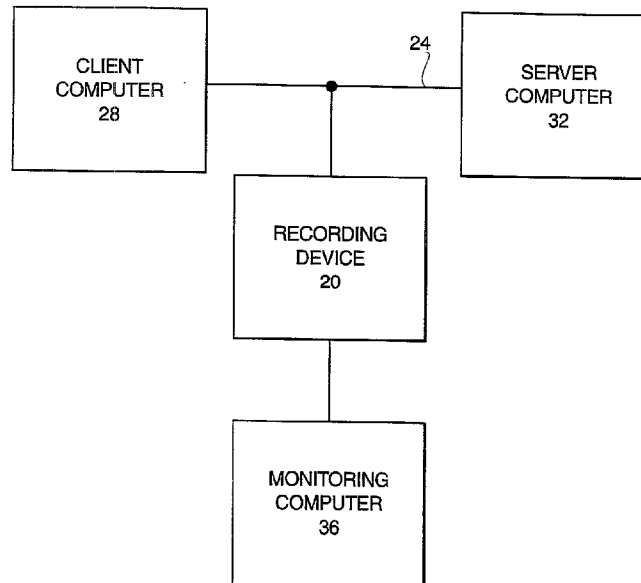

- (72) ROSBOROUGH, James M., US  
(71) ADVANCED SYSTEM TECHNOLOGIES, INC., US  
(51) Int.Cl.<sup>6</sup> H04L 12/26, H04L 12/56  
(30) 1995/08/10 (08/513,435) US  
(54) **PROCEDE ET APPAREIL DE MESURE DE TEMPS DE  
REPONSE**  
(54) **RESPONSE TIME MEASUREMENT APPARATUS AND  
METHOD**



(57) Procédé et appareil permettant de mesurer le temps de réponse (36) d'une transaction, et identifiant une séquence de demande de services correspondant à une transaction ainsi que les heures de démarrage et d'arrêt de la transaction. Cette invention peut s'appliquer sans altération et sans perturbation aux paquets de services (38) transmis entre une source (32) et un noeud récepteur (28).

(57) The present invention provides a method and apparatus for measuring transaction response time (36). The method and apparatus can identify service request sequence corresponding to a transaction and the start and stop times for transaction. The invention can be applied non-intrusively/non-invasively to the service packets (38) communicated between a source (32) and a destination node (28).

**PCT**WORLD INTELLECTUAL PROPERTY ORGANIZATION  
International Bureau

## INTERNATIONAL APPLICATION PUBLISHED UNDER THE PATENT COOPERATION TREATY (PCT)

<b>(51) International Patent Classification <sup>6</sup> :</b> <b>G06F 17/00</b>	<b>A1</b>	<b>(11) International Publication Number:</b> <b>WO 97/06494</b> <b>(43) International Publication Date:</b> 20 February 1997 (20.02.97)
<b>(21) International Application Number:</b> PCT/US96/12035 <b>(22) International Filing Date:</b> 19 July 1996 (19.07.96) <b>(30) Priority Data:</b> 513,435                      10 August 1995 (10.08.95)                      US <b>(71) Applicant:</b> ADVANCED SYSTEM TECHNOLOGIES, INC. [US/US]; Suite 260, 12200 East Briarwood Avenue, Englewood, CO 80112 (US). <b>(72) Inventor:</b> ROSBOROUGH, James, M.; 2400 South Brentwood Street, Lakewood, CO 80227 (US). <b>(74) Agents:</b> SWARTZ, Douglas, W. et al.; Sheridan Ross & McIntosh, Suite 3500, 1700 Lincoln Street, Denver, CO 80203 (US).	<b>(81) Designated States:</b> AL, AM, AT, AU, AZ, BB, BG, BR, BY, CA, CH, CN, CU, CZ, DE, DK, EE, ES, FI, GB, GE, HU, IL, IS, JP, KE, KG, KP, KR, KZ, LK, LR, LS, LT, LU, LV, MD, MG, MK, MN, MW, MX, NO, NZ, PL, PT, RO, RU, SD, SE, SG, SI, SK, TJ, TM, TR, TT, UA, UG, UZ, VN, ARIPO patent (KE, LS, MW, SD, SZ, UG), Eurasian patent (AM, AZ, BY, KG, KZ, MD, RU, TJ, TM), European patent (AT, BE, CH, DE, DK, ES, FI, FR, GB, GR, IE, IT, LU, MC, NL, PT, SE), OAPI patent (BF, BJ, CF, CG, CI, CM, GA, GN, ML, MR, NE, SN, TD, TG).  <b>Published</b> <i>With international search report.</i>	

**(54) Title:** RESPONSE TIME MEASUREMENT APPARATUS AND METHOD**(57) Abstract**

The present invention provides a method and apparatus for measuring transaction response time (36). The method and apparatus can identify service request sequence corresponding to a transaction and the start and stop times for transaction. The invention can be applied non-intrusively/non-invasively to the service packets (38) communicated between a source (32) and a destination node (28).

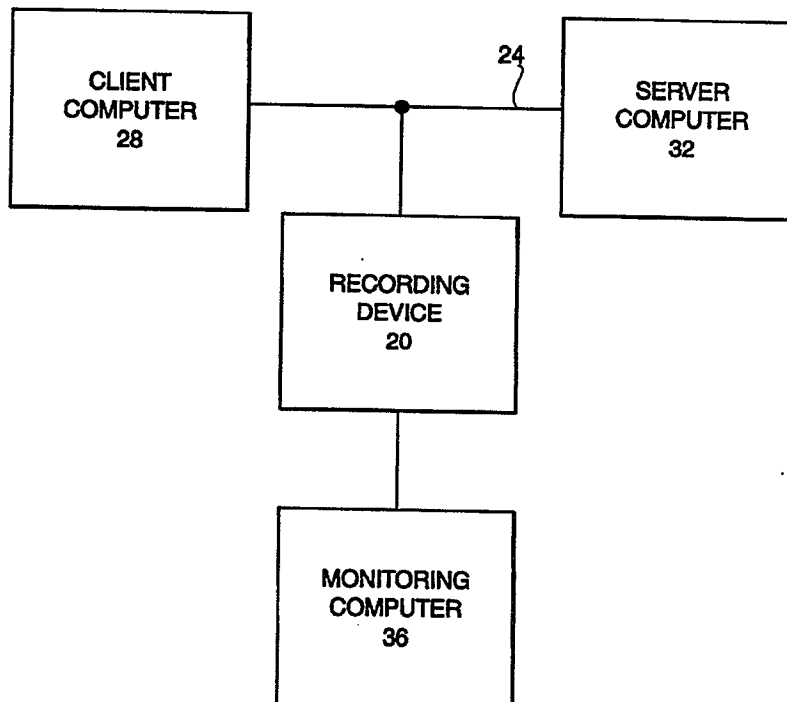

## RESPONSE TIME MEASUREMENT APPARATUS AND METHOD

## FIELD OF THE INVENTION

5           The present invention is directed generally to the measurement of response time in computer applications and specifically to the use of non-intrusive devices to measure response time in multi-tiered computer networks.

## 10                           BACKGROUND OF THE INVENTION

          Multi-tiered computer networks are widely used to provide one or more users with a wide variety of information and computer resources. In multi-tiered computer networks, client computers (e.g., users) interact  
15 with server computers to perform an application which is partitioned into one or more transactions. An application is a group of meaningful transactions, and a transaction is a unit of meaningful work as perceived by the user. A transaction is typically a collection of service requests,  
20 with the service request typically being a collection of service packets. A service packet is simply an item of information, or a message, communicated between computers. In the course of performing a transaction, the client computer may request one or more of the server computers to  
25 transfer service packets containing data to the client computer or provide service packets containing data to the server computer(s) to permit the server computer(s) to process the request. The server computers can in turn request the services of other server computers in

-2-

connection with the data transfer request from the client computer.

Performance monitoring of the network is important to ascertain periods of significant transaction user delays and user productivity. Performance monitoring generally seeks to measure the response time for a transaction or application. The response time is the time required for the servers and network to perform the transaction or application. Statistical analysis can be performed on the response times to facilitate analysis of servers and network performance.

Two methods are commonly used to monitor network performance and provide response times. Intrusive/invasive monitoring techniques alter the software code on the client computer to include a marker command. The marker commands inform a listening device of transmission of the initial service request packet to initiate timing measurement and receipt of the final results or acknowledgement packet to cease timing measurement. Non-intrusive/non-invasive monitoring techniques, in contrast, typically do not alter the software code. Rather, a probe is inserted into a communication line between the client and server computers to monitor the delays between transmission of individual packets between the client and server computers to provide a rough estimate of response time.

Intrusive/invasive and non-intrusive/non-invasive techniques each have a number of drawbacks. In the case of intrusive/invasive techniques, though the transaction

-3-

response time is provided, few multi-tiered applications are written with embedded marker commands in the code. Even if the applications were to have embedded marker commands, technical problems, can arise due to and consolidation of application-embedded response time statistics to a central location, especially for mobile user computers. In the case of non-intrusive/non-invasive techniques, it is only possible to determine the rate of information transmission between the computers for individual packets. Such techniques are typically unable to determine the response time for a transaction or application. Neither intrusive/invasive nor non-intrusive/non-invasive monitoring techniques are able to match, especially in multi-tiered networks, individual packets with the corresponding transaction to compute a response time for the transaction or related application. As noted above, each of the server computers performing an application can process a series of individual service requests pertaining to a variety of different user transactions. Existing monitoring techniques are unable to match the service packets in the various service requests to a specific transaction.

There is a need for an apparatus and method for measuring the response time for a transaction or an application, especially in multi-tiered computer networks. There is a related need for an apparatus and method for measuring the response time for a transaction or an application using non-intrusive/non-invasive techniques.

-4-

There is a need for an apparatus and method for measuring the response time for a transaction or an application that is able to match individual service packets with the corresponding transaction or application.

5

## SUMMARY OF THE INVENTION

The present invention addresses these and other needs by providing in one aspect a method for identifying a transaction corresponding to a plurality of service packets communicated between a source node and a destination node. The method includes the steps: (i) providing a communications data set including a plurality of service packets and information relating to the order in which the service packets are communicated on a communications line between the source and destination nodes and (ii) comparing the communications data set against a pattern characterization data set to determine whether at least a portion of the plurality of service packets are part of the transaction. The pattern characterization data set includes information relating to a predetermined ordering of service packets that comprise the transaction. The method is amenable to non-intrusive/non-invasive measuring techniques and can provide near real-time response time information, even for multi-tiered computer networks.

25 The invention is based in part upon the recognition that the service packets communicated along the communications line constitute patterns of service requests that occur repeatedly in an operational environment. These

-5-

service request patterns correspond to different transaction types. It has been discovered that these service request patterns can be determined using signal processing techniques. Once identified, the start and stop  
5 times for the pattern can be determined to provide a response time for the transaction.

A probe can be used to read the packets on a real-time basis from the communications line with the packets being recorded along with a received time (e.g., the time at  
10 which the packet was read by the probe) in the communications data set.

The packets can be filtered based on a node address and/or port number. In a preferred embodiment, the service packets correspond to a plurality of threads and the  
15 packets are sorted by thread.

The service request packets can be identified by their contents and destination. The service result packets can then be correlated with the corresponding service request  
20 packets. The start and stop times for the service request can then be determined.

After identification of the service requests corresponding to the transaction, the response time for the transaction can be determined using the various start and  
25 stop times for the service requests.

In another aspect of the present invention, a non-intrusive system is provided for identifying a transaction comprising a plurality of service packets communicated

-6-

between source and destination nodes. The system includes:  
(i) a device for recording a plurality of service packets  
communicated on the communications line and (ii) a device,  
in communication with the recording device, for identifying  
5 a transaction that includes at least a portion of the  
plurality of packets.

In yet another aspect, the present invention provides  
a method for identifying a transaction comprising a  
plurality of service packets communicated between source  
10 and destination nodes that includes the steps: (i)  
providing a communications data set including (a) a  
plurality of service packets corresponding to a plurality  
of service requests and (b) the start and stop times for  
each service request and (ii) comparing the time interval  
15 between the stop of a first service request and the start  
of a second service request against a predetermined value  
for the time interval to identify a sequence of service  
requests that comprise a transaction.

The comparing step can be performed in several  
20 iterations where the time interval is varied to select an  
optimal predetermined value for the time interval between  
service requests to yield a substantially optimal listing  
of service request sequences as a possible transaction. The  
resultant number of transaction service request patterns  
25 are then used to determine an optimal value for the  
predetermined time interval. For a range of time intervals  
the number of transaction service request patterns remains  
constant. The optimal value for the predetermined time



-7-

interval is the midpoint of this range of values. By way of example, after identifying a service request sequence(s) using the predetermined values, the method can further include selecting a second predetermined value, comparing the time intervals, between service requests, against the second predetermined value to identify a second sequence(s) of service requests corresponding to a second transaction(s), and recording the second sequence(s) of service requests and the number of occurrences of each of the second sequence(s) in a second data set. The method next selecting a third predetermined value (which is the optimal predetermined value) based on the relationship between (i) the number of the sequence(s) of service requests and the predetermined value and (ii) the number of the second sequence(s) of service requests and the second predetermined value. The method then comprises as before the time interval between service requests against the third predetermined value for the time interval to identify a third sequence(s) of service requests corresponding to a third transaction(s). The service request sequence for the third transaction is deemed to be the optimal sequence. The third sequence is then compared against the communications data set to determine whether at least a portion of the plurality of service requests correspond to one or more transaction(s).

The method produces the pattern characterization data set referred to above. The pattern characterization data set lists a plurality of service request sequences for

-8-

comparison against the service requests from the comparing step. This additional comparison step is to determine if the service requests as ordered by time are contained in the pattern characterization data set.

5 In a final aspect, the present invention includes a non-intrusive system for determining transaction level activity between a source and destination node. The system includes: (i) a device for recording a plurality of service packets communicated on a communications line between  
10 source and destination nodes and (ii) a device for determining the number of transactions in communication with the recording device. The service packets relate to a number of transactions and the recording device provides the communications data set.

15 In one embodiment, the determining device is a device for comparing the time interval between the stop time of a first service request and the start time of a second service request against a predetermined value for the time interval to identify a sequence of service requests in the  
20 communications data set that together comprise a transaction.

#### BRIEF DESCRIPTION OF THE DRAWINGS

Fig. 1 depicts an embodiment of the present invention  
25 connected to a computer network;

Fig. 2 depicts another embodiment of the present invention connected to a multi-tiered computer network;

Fig. 3 depicts a service packet;

-9-

Fig. 4 depicts an example of the service packets in a service request;

Fig. 5 depicts the response time for a transaction involving a number of service requests;

5 Figs. 6A-E depict a first embodiment of a method according to the present invention for determining response time;

Fig. 7 depicts the interactions of service requests in the pattern finding and matching steps;

10 Fig. 8 is a plot of the predetermined time value against the number of transactions discovered;

Figs. 9A-B depict a second embodiment of a method according to the present invention for determining response time;

15 Figs. 10-11 depict the interactions of service requests in the pattern finding and matching steps; and

Fig. 12 is a graphical presentation of CPU utilization versus response time for a transaction.

20 DETAILED DESCRIPTION

The present invention is directed to a method and apparatus for measuring response times for a transaction or an application using non-intrusive/non-invasive techniques. As noted above, non-intrusive/non-invasive monitoring techniques do not interrupt the software code to measure response time. Rather, such techniques monitor the network communications between the client computer and the various server computers. Unlike existing performance monitoring

25

-10-

methods, the method of the present invention matches selected service packets and associated start and stop time information for the service packets with the corresponding transaction or application. After the matching step, the method provides response times for the transaction or application. The present invention is useful not only for performance monitoring but also for billing and monitoring of service level agreement compliance.

#### The Apparatus Configuration

10 The apparatus configuration according to the present invention is depicted in Figs. 1 and 2. Referring to Fig. 1, the simplest single network segment is depicted. In the network, a recording device or probe 20 is connected to a communication line or busline 24 between a client computer 15 28 and a server computer 32. The recording device 20 selects service packets transmitted along the communication line 24 and provides the service packet and the time at which the service packet was received by the recording device 20 to the monitoring computer 36 for analysis. Fig. 20 2 depicts a more complex multi-tiered architecture with multiple network segments. Recording devices 20 a,b are connected via a communications device 22, such as a modem, to the communication lines 24a,b between the network segments 26a,b. The network segments include client 25 computer 28 and server computers 32a,b c,d and the communication lines 24 a, b. As can be seen from these figures, the present invention does not measure response time within the various client and server computers as in

-11-

intrusive/invasive monitoring techniques, but measures response time by monitoring the network communications on the communications line between the client computer and the various server computers.

5           The number and locations of the recording device(s) 20 in a multi-tiered computer network depend upon the application. Typically, a recording device 20 will be located on any portion of the communication line 24 that is between the points of access of the drivers of client or  
10 server computers to the communications line 24. In this manner, all of the service packets communicated on the communications line 24 will be read by a recording device 20 and an accurate determination of the response time for a transaction or application involving multiple client  
15 and/or server computers can be made.

          The text of a typical service packet communicated between computers in a multi-tiered computer network is depicted in Fig. 3. As can be seen from Fig. 3, a service packet 38 typically includes a node address 40, which  
20 identifies the source and destination of the service packet, a port number 44, and additional information 48. Depending upon the application, the service packet can have additional information, such as a database request, file system request and object broker request.

25           There are generally two types of service packets, namely service request and service results packets. Service request packets request a server computer to perform a specific action. Service results packets are

-12-

service packets generated in response to the service request packet. Service results packets can contain a variety of information including the information requested by the service request packet.

5 To illustrate the use of two types of service packets in a service request, an example of a service request involving numerous service packets is depicted in Fig. 4. A typical service request 52 begins with the service request packet 56 (which can be multiple service packets)  
10 issued by, for example, a client computer to a server computer. The server computer then transmits a service request acknowledgement packet 60 to the client computer and begins processing the request. When the server computer has completed processing the service request, the  
15 server computer sends a service results notification packet 64 to the client computer that the server computer is ready to send the service request's data to the client computer. The client computer then transmits a service results transmission packet 68 requesting transmission of the data.  
20 The service computer commences transmitting service results packets 72. The service results completion packet 76 notifies the client computer that the final service results packet has been transmitted, and the service results acknowledgement packet 80 notifies the server computer that  
25 the information has been received. The response time to complete the service request is the difference between the received time for the service request packet 56 and the

-13-

received time for the service completion acknowledgment packet 80.

To further illustrate the response time for a transaction, an example of a transaction involving numerous service requests will be described with reference to Figs. 2 and 5. A type "A" transaction executed on the client computer 28 makes service request 1 of server computer 32a and service request 2 of server computer 32b. To complete service request 1, server computer 32b makes service request 3 of server computer 32c. When service request 1 is completed, the type "A" transaction makes service requests 4 and 5 of server computer 32d and service type 6 (e.g., service request 6) of server computer 32c. The pattern of service requests to the various server computers identifies the transaction as a type "A" transaction. The response time for the type "A" transaction is measured from the start time of service requests 1 and 2 to the stop time of service request 5. Thus, the transaction response time is simply a collection of individual service request response times.

#### The Filtering of Service Packets

Figs. 6A-E provide a flow schematic depicting a first embodiment of a performance monitoring method according to the present invention. The method collects selected service packets from the recording device(s) and filters the selected service packets to form a communications data set. The network communications are filtered to yield only those service packets relevant to the application(s) of interest.

-14-

As will be appreciated, it is possible that multiple applications on the same client computer request the same type of services from a specific server computer. It is also possible that a service provider may migrate from one server computer to another server computer of the same type.

The first embodiment is based on the assumption that the packets of a given transaction are located on only one thread. A given thread can, however, have packets from more than one transaction. A second embodiment of the present invention is discussed below for an application in which a given transaction occurs on more than one thread.

As used herein, a thread is a specific identifiable connection or session between a service requestor node and a service provider node. A thread is preferably identified such that it can have only one service request on it at a given point in time. As will be appreciated, in some applications the node address is not an adequate identifier of each thread because there can be multiple sessions for a given node address. In such cases, the connection or session identification information is used to further identify the thread to which the service packet is to be dispatched. A thread can be either a user thread, which is a thread that is uniquely identifiable to a specific client computer, or a shared thread, which is a thread shared among multiple user requests.

Referring to Fig. 6A, one or more recording devices first read in command box 100 one or more service packets



-15-

from the communications line 24. Based on the node address or other thread identification information, a recording device 20 determines if the service packet pertains to the client computer(s) and/or server computer(s) (e.g., threads) of interest. If so, the service packet is recorded and the time the service packet was read by the recording device 20 (e.g., received time); otherwise, no record is made of the service packet. If one were interested in a particular subset of service requests, the recording device 20 could filter based not only on the node address or other thread identification information but also on the port number. The port number is useful for filtering if the application is configured such that there is only one service request on a port at a given point in time.

In a command box 104, the service packet is recorded in a communications data set by being dispatched to an appropriate thread data set. The communications data set contains the service packets read by all of the recording devices organized by the thread. There is a thread data set for each thread. In most applications, a plurality of thread data sets in the communications data set are active at any point in time.

The service packet is next examined in decision box 108 to determine if it is a service request packet. This is accomplished by searching in the text of the service packet for a key word(s) and/or symbol(s) unique to a service request packet; that is, the words and/or symbols are not used in service results packets. The words and/or

-16-

symbols used in the search can be specific to a given transaction and/or application.

If the service packet is an initial service request packet, the subsequent service packets are read in command  
5 box 112 to identify in decision box 116 the service completion packet. The service completion packet is the final service results packet in a service request. As noted above, there will only be one set of service packets for a specific service request that is serial on the thread  
10 at a particular moment in time. The set of service packets for a given service request comprise a service data subset. Accordingly, the matching of the service request packet with the corresponding service results packets is a relatively straightforward process.

15 There are two methods to identify the service completion packet. In one method, the text in each service results packet is searched for key word(s) and/or symbol(s) only associated with one or more of the service results packets. In the other method, the service packet having  
20 the latest received time is assumed to be the service completion packet. In other words, the last service packet on the thread before the immediately succeeding service request packet is assumed to be the service completion packet. The last packet on the thread can be sent by either the  
25 client or server computer. Which of the two methods is preferred in a specific case depends upon the application.

After the service request and service completion packets are identified in decision box 116, the start and

-17-

stop times for the service request are recorded in command box 120 in the communications data set along with the thread identification information and a service request identifier and possibly recording device location. The start time is the received time for the service request packet, and the stop time is the received time for the service completion packet. The service request identifier can be any suitable means for identifying the type of service to which the service request pertains. By way of example, the service request identifier can be a command or a portion thereof, especially in data processing applications. The communications data set can include other information, including the location of the recording device 20 on the communications line 24, network type and other recording information.

The preceding steps are repeated on a packet-by-packet basis for the service packets communicated along a section of the communications line 24 over a selected time period. The time period can be discrete or continuous. In either case, the communications data set is, after an appropriate time interval, subjected to the steps discussed below to identify response time.

For service packets having encrypted or compressed data, it is typically necessary to know or determine the compression algorithm before applying the filtering steps. Additional steps may therefore be required to unencrypt or uncompress the packets.

-18-

The Transaction Pattern Finding Steps

In a series of transaction pattern finding steps discussed in detail below, the monitoring computer 36 analyzes the communications data set to identify a sequence of service requests that together comprise a possible transaction pattern. Generally, the monitoring computer 36 identifies the service request sequence by comparing the time interval between the stop time of a first service request and the start time of a succeeding service request against a predetermined value for the time interval. If the time interval is less than or equal to the predetermined value, the service requests are deemed to be part of the same transaction and if the time interval is more than the predetermined value, the service requests are deemed to be part of separate transactions. Accordingly, the selected time interval is selected based on the maximum projected time interval between adjacent service requests for the two service requests to be considered part of the same transaction.

Referring to Fig. 6B to initiate the transaction pattern finding steps, a selected time interval can be increased or decreased by a selected time increment in decision box 124. If the selected time interval is at the upper or lower limit of the desired range of time interval values, processing is terminated. The selected time interval and incremental increases or decreases thereof are discussed in greater detail below. As will be appreciated, a smaller selected time interval yields a smaller number of

-19-

possible transaction patterns than a larger selected time interval.

After selection of the appropriate selected time interval, the monitoring computer 36 in command box 128  
5 opens for all of the selected time intervals a service request file, to contain information generated in the succeeding steps. As discussed below, the service request file will contain the service requests sorted by thread and selected time interval.

10 Returning to Fig. 6B, the monitoring computer next reads in command box 132 a service request from the communications data set and, in decision box 136, determines if all of the service requests in the communications data set have been read. If so, the  
15 monitoring computer goes to decision box 124. If not, the monitoring computer dispatches the service request in command box 144 to the appropriate thread to form a thread data set with one thread data set existing for each thread. As the various service requests are read from the  
20 communications data set and dispatched to the thread data sets for each selected time interval, a collection of service requests can form in each thread data set. The service requests in each thread data subset are ordered by their respective start and stop times. Thus, as noted  
25 above, each of the service requests in the collection is separated from an adjacent service request by a time interval. Command boxes 132, 144 are repeated until all of

-20-

the service requests in the communications data set are sorted by thread for each selected time interval.

After the computer in decision box 124 determines the all selected time intervals have been analyzed, the computer proceeds to command box 140. In command box 140, the service requests from the communications data set are all received into the various thread data sets. As will be appreciated, the ensuing steps in Fig. 6C are performed for each selected time interval in the service request file.

The service requests in each thread data set are next examined in decision box 148 to determine if the various service requests are local to another service request in the thread data set. A service request is local to another service request if the time interval between the service requests is no more than the selected time interval. If the service requests are local to one another, the service requests are considered to be components of the same transaction. If the service requests are not local to one another, the service requests are considered to be components of different or separate transactions.

Referring to Fig. 7, a string or sequence of service requests of the type generated in each thread data set in the service request file is illustrated. The string or sequence of service requests can refer either to a collection of service requests that are local with respect to at least one other service request in the sequence or to a single service request that is not local to another service request. As will be appreciated, a possible

-21-

transaction pattern can have one or more service requests. Thus, in Fig 7, the time intervals  $\Delta T_{a-d}$  separating the service requests 156a-e are no more than the selected time interval.

5           If a service request in a thread data set is local to another service request in the thread data set, the service requests in command box 150 are combined and added as a new possible transaction pattern to a possible transaction list in a pattern characterization data set in the service  
10 request file. As will be appreciated, the service request can be local to another service request that is either discrete or part of a string or sequence of a number of service requests. In this manner, a sequence of service requests corresponding to a given possible transaction  
15 pattern is progressively expanded to include additional service requests.

The pattern characterization data set can include a variety of information, including the various selected time intervals and the corresponding thread data sets, with each  
20 thread data set including variables for identification of the thread, the various service requests associated with the thread organized in service request sequences, and the number of occurrences of each service request sequence. This list of service request sequences is hereinafter  
25 referred to as the possible transaction pattern list.

The pattern characterization data set can also include other information depending upon the application. By way of example, the pattern characterization data set can

-22-

include the transaction type associated with each sequence of service requests. The transaction type can be based upon the identity of one or more of the service requests in the service request sequence corresponding to the transaction  
5 (e.g., the service request identifier).

The generation of the pattern characterization data set is initiated in command box 140 by receiving a service request from a thread data set in the record file. If the subject service request is not local to a previous service  
10 request in the thread data set, the service request sequence that immediately precedes in time the subject service request, if any, is compared in decision box 152 to previously identified patterns in all of the thread data sets for the related selected time interval in the pattern  
15 characterization data set to determine if the pattern has previously been recorded (discovered) for the selected time interval.

If the preceding service request sequence is not a new possible transaction pattern, the number of occurrences of  
20 the possible transaction pattern for the selected time interval is incremented in command box 156. More specifically, the recorded number of occurrences of the possible transaction pattern having the same sequence of service requests is increased by one.

25 Returning to decision box 152, if the service request sequence preceding the subject service request is a new possible transaction pattern for the selected time interval, the monitoring computer in command box 160



-23-

records the service request sequence on the possible transaction pattern list.

After command boxes 156, 160, the possible transaction pattern list is initialized in command box 164 to begin a new service request string for the selected time interval beginning with the subject service request. Based on the fact that the subject service request is not local to the immediately preceding service request, the program assumes that the service request sequence of which the immediately preceding service request is a part is completed. Because the service request is not local to a prior service request, the monitoring computer assumes that the service request is a part of a new service request sequence.

After command box 164 is completed, the monitoring computer determines in decision box 168 if the end of the thread data set(s) in the record file has been reached for all of the service requests in all of the selected time intervals. If so, the process is terminated. If not, the computer proceeds to command box 172 and receives another service request from a thread data set in the record file.

After command boxes 150 and 172 are completed, the monitoring computer returns to command box 140 and the preceding steps are repeated until all service requests in the record file have been read and processed.

In a communications data set having a plurality of threads, the monitoring computer applies the transaction pattern finding steps in parallel to service requests from different threads. Thus, the service requests in a

-24-

plurality of different thread data sets are analyzed simultaneously. Accordingly, at any point in time, a plurality of thread data sets can be active.

In a preferred embodiment, an optimal value for the selected time interval is selected by first selecting a series of selected time intervals for decision box 124. As noted above, the predetermined values can be selected using a predetermined increment in decision box 124. The values used for the selected time intervals are usually subsecond intervals ranging, for example, from about 50 to about 500 milliseconds.

Referring to Fig. 8, after the performance of the above-noted command and decision boxes with various selected time intervals, the numbers of possible transaction patterns from the pattern characterization data set (e.g., vertical axis) are plotted against the corresponding selected time intervals (e.g., horizontal axis). An optimal value for the selected time interval is selected in the central portion of the plateau 176 on the curve 180. Using the optimal value in decision box 124, the transaction pattern finding steps are repeated to yield a second pattern characterization data set. The transaction patterns in the second pattern characterization data set are believed to be the substantially optimal listing of transaction patterns for the various service requests in the record file.

Referring to Fig. 9A, the second embodiment of the present invention is depicted. Fig. 9A replaces Fig. 6C

-25-

and otherwise has the same steps as the first embodiment in Figs. 6A and B. Fig. 6C is substantially identical to Fig. 9A except for decision box 200 and command box 204. As noted above, the second embodiment, unlike the first  
5 embodiment, is applicable to applications and/or transactions that have more than one thread for a transaction.

There are generally three situations where an application or transaction has more than one thread per  
10 transaction. In one situation, a specific thread will perform only one service request type. After the service request type is performed, the application or transaction utilizes other threads. In another case, the application or transaction is performed on a number of user threads in  
15 sequence. For example, a number of service requests are performed on one user thread and a number of later service requests are performed on another user thread. In this manner, the application or transaction can move back and forth among user threads. In the last case, two or more  
20 client computers use a shared thread to perform service requests.

To address the use of more than one thread for a transaction, decision box 200, in response to a negative response to decision box 148, determines if the service  
25 request sequence that immediately precedes in time the subject service request is local to a service request in other thread data sets.

-26-

Referring to Figs. 7 and 10-11, the three possible results in decision box 200 of comparing the service requests in different thread data sets are illustrated. In Fig. 7, a service request 156d in one thread data set is  
5 local to the immediately preceding service request sequence (e.g., service requests 156a-c) in another thread data set because a time interval  $\Delta T_c$  between the service request 156c and a service request 156d in the service request sequence is no more than the selected time interval. In  
10 Fig. 10, a service request 210 in one thread data set is not local to the service request sequence (e.g., service requests 214a-b) in another thread data set because the service request overlaps the service request sequence. In other words, the service request is not local to the  
15 service request sequence if the service request was initiated or incomplete before the completion or initiation, respectively, of a service request in the service request sequence. For a discrete service request or service request sequence to be copied to another thread  
20 data set, it is thus critical that the service request or service request sequence does not overlap a portion of the service request sequence on the other thread data set (e.g., service requests 214a-b). In Fig. 11, a service request 218 in one thread data set is not local to the  
25 service request sequence (e.g., service requests 222a-b) in another thread data set because the time intervals  $\Delta T_e$  between the service request 218 and the service requests

-27-

222b in the service request sequence are greater than the selected time interval.

A service request or service request sequence can be transferred to one or more thread data sets in series or parallel. For example, the service request or service request sequence in one thread data set can be sequentially transferred to a second thread data set and to a third thread data set (e.g., series) or to two or more other thread data sets at substantially the same time (e.g., parallel).

If the service request sequence is local to a service request in another thread, the service request sequence in command box 204 is transferred to the possible transaction pattern list in the other thread data set. After completing command box 204, the monitoring computer returns to command box 140.

If the service request sequence is not local to a service request in another thread, the monitoring computer continues to decision box 152.

20

#### The Transaction Pattern Matching Steps

In the transaction pattern matching steps, the communications data set is compared against the pattern characterization data set from the transaction pattern finding steps to determine whether at least a portion of the plurality of service packets are part of one or more transactions. The start and stop times of the service requests corresponding to the service packets can then be

-28-

used to provide a response time for the transaction and/or application.

Referring to Fig. 6D, to initiate the transaction pattern matching steps, a service request file is opened in command box 250 to receive service requests read from the communications data set.

In command box 254, a service request is read from the communications data set and dispatched in command box 258 to the appropriate thread to form a thread data set in the service record file with one thread data set existing for each thread.

In decision box 256, the monitoring computer determines if the last service request in the communications data set has been read. If so, the monitoring computer proceeds to command box 262. If not, the monitoring computer returns to command box 254. In this manner, all service requests in the communications data set are sorted by thread data set before the steps of Fig. 6E.

Referring to Fig. 6E, the service request sequences in each thread data set, which are ordered based on start and stop times, are compared against the pattern characterization data set to determine whether at least a portion of the service request sequences are part of a possible transaction pattern.

In decision box 266, the matching process is initiated by comparing a subject service request in a thread data set against the initial service request in the various

-29-

transaction patterns obtained from all of the thread data sets in the pattern characterization data set. If the service request does not match any of the initial service requests in the transaction patterns obtained for all of the threads, the monitoring computer receives another service request in command box 262 and the decision box 266 is repeated. If the service request matches an initial service request, another service request from the thread data set is received in command box 270.

10 In decision box 274, the monitoring computer determines whether the service request received in command box 270 is local to the initial service request identified in decision box 266. If not, the monitoring computer returns to command box 262 and repeats the steps described above with another service request. If so, the monitoring computer in decision box 278 determines based on the transaction pattern in the pattern characterization data set if the service request read in command box 270 is the final service request in the transaction pattern.

20 To determine if the service request is the final service request in a probable transaction, the monitoring computer relies upon the sequence of service requests in the transaction patterns in the thread data set. If the service request is not the final service request in the probable transaction, the monitoring computer returns to command box 270. If the service request is the final service request, the monitoring computer records in command

-30-

box 282 the start and stop time for the probable transaction pattern and proceeds to decision box 286.

In decision box 282, if it is determined that if all of the service requests in the thread data sets have been  
5 characterized into service request sequences, the program is terminated. Otherwise, the computer returns to command box 262. Preferably, the preceding steps are performed in parallel for all of the thread data sets.

The preceding steps yield a pattern analysis data set  
10 containing the various service request sequences that together comprise the various transactions, the response times for each transaction, and the location of the recording device. The pattern analysis data set can include additional information, such as user identification  
15 and thread identification.

Referring to Fig. 9B, the second embodiment of the present invention is depicted. Fig. 9B replaces Fig. 6E and otherwise has the same steps as the first embodiment in Fig. 6D. Fig. 9B is substantially identical to Fig. 6E  
20 except for decision box 300 and command box 304. To address the use of more than one thread for a transaction, decision box 300, in response to a negative response to decision box 274, determines if the service request sequence is local to a service request in another thread data set. If the  
25 service request sequence is local to a service request in one or more other thread data set(s), the service request sequence in command box 304 is transferred to the other thread data set(s). After completing command box 304, the



-31-

monitoring computer returns to command box 262. If the service request sequence is not local to a service request in another thread data set, the monitoring computer continues to decision box 278.

5           After completion of the preceding steps of the first or second embodiments, the information in the pattern analysis data set can be used to generate performance statistics and transaction counts. For example, the resulting transaction response data can be aggregated into  
10 a fixed time interval, such as five minutes, and response time statistics, such as maximum, mean, standard deviation, and 70th, 80th and 90th percentiles, calculated by transaction type. The discrete transaction response time information can be used to analyze response times by  
15 service request breakdown within the transaction or by user class and other variants. An example of an analysis report for a transaction is shown in Fig. 12. The data can also be used to determine transaction counts performed over a discrete time period.

20           The pattern characterization data set can include transaction patterns determined by a process other than the transaction pattern finding steps. By way of example, a test can be performed for the transactions of interest to identify the service request sequences generated during the  
25 transactions. This method may be incomplete in some cases because a transaction can generate a multiplicity of service request sequences based on the particular responses selected by the user.

-32-

The transaction pattern finding and matching steps can be modified to discard incomplete service request sequences. Such service request sequences are typically the result of initiating the selected time period for recording of service packets after a transaction has already started or ending the selected time period before a transaction has ended. To eliminate incomplete service request sequences, any service request sequence in a thread data set that is not separated from a preceding or succeeding service request by a time interval that is more than the selected time interval is discarded. This modification assumes, of course, that any service requests separated by a time interval that is more than the selected time interval are not part of the same service request sequence.

While various embodiments of the present invention have been described in detail, it is apparent that modifications and adaptations of those embodiments will occur to those skilled in the art. It is to be expressly understood, however, that such modifications and adaptations are within the scope of the present invention, as set forth in the appended claims.

-33-

What is claimed is:

1. A method for identifying a transaction corresponding to a plurality of service packets communicated between a source node and a destination node,  
5 comprising:

providing a communications data set comprising a plurality of service packets and information relating to the order in which said service packets are communicated on a communications line between a source node and a  
10 destination node; and

comparing said communications data set against a pattern characterization data set comprising information relating to a predetermined ordering of service packets corresponding to a transaction to determine whether at  
15 least a portion of said plurality of service packets correspond to said transaction.

2. The method as claimed in Claim 1, wherein said communications data set includes a received time corresponding to each service packet and said providing  
20 step comprises:

reading with a probe said service packets from said communications line; and

recording said service packets and said received time, wherein said received time corresponds substantially to the  
25 time said packet is read by said probe.

3. The method as claimed in Claim 2, wherein said probe is located between said source and destination nodes and further comprising:

-34-

adding to said received time for a received packet a transit time corresponding substantially to the time required by a service packet to travel from said probe to at least one of said source node and destination node.

5           4. The method as claimed in Claim 1, wherein a plurality of said service packets have at least one of a node address and port number and said communications data set includes a received time corresponding to each service packet and said providing step comprises:

10           reading with a probe said service packets from said communications line;

          filtering said service packets based on at least one of node address and port number to form filtered service packets; and

15           recording said filtered service packets and said received time, wherein said received time corresponds substantially to the time said filtered service packet is read by said probe.

20           5. The method as claimed in Claim 1, wherein said service packets correspond to a plurality of threads with each thread corresponding to thread identification information and said comparing step comprises:

          sorting said service packets in said communications data set into a plurality of thread data sets wherein the  
25           service packets in each thread data set have the same thread identification information.

-35-

6. The method as claimed in Claim 1, wherein said service packets include service request packets and service results packets, each service request corresponds to a service request, and said comparing step comprises:

5 identifying service request packets in said service packets based on the contents of said service packets.

7. The method as claimed in Claim 1, wherein said service packets include service request packets and service results packets and said comparing step comprises:

10 identifying service request packets in said service packets based on the contents of said service packets;

correlating service results packets with corresponding service request packets; and

15 determining the start and stop times for the service request.

8. The method as claimed in Claim 7, further comprising:

computing a response time for said transaction.

20 9. The method as claimed in Claim 7, further comprising:

comparing the time interval between the stop of a first service request and the start of a second service request against a predetermined value for said time interval to identify a sequence of service requests  
25 corresponding to a transaction, wherein said predetermined ordering of service packets corresponds to said sequence of service requests.

-36-

10. The method as claimed in Claim 1, wherein said service packets correspond to a plurality of service requests and said comparing step comprises:

5 first matching a first service request in said communications data set with a first service request in said predetermined ordering of service packets;

10 second matching a second service request in said communications data set with a second service request in said predetermined ordering of service packets, wherein a time interval between said first and second service requests is no more than a predetermined value.

11. The method as claimed in Claim 1, wherein said service packets correspond to a plurality of service requests, said service requests correspond to a plurality of thread data sets, and said comparing step comprises:

15 first matching a first service request corresponding to a first thread with a first service request in said predetermined ordering of service packets;

20 second matching a second service request corresponding to a second thread with a second service request in said predetermined ordering of service packets, wherein a time interval between said first and second service requests is no more than a predetermined value.

25 12. A non-intrusive system for identifying a transaction corresponding to a plurality of service packets communicated between a source node and a destination node, comprising:

-37-

means for recording a plurality of service packets communicated on a communications line between a source node and a destination node, said recording means being in communication with said communications line; and

5 means, in communication with said recording means, for identifying a transaction corresponding to at least a portion of said plurality of packets.

13. The non-intrusive system as claimed in Claim 12, wherein said identifying means comprises means for  
10 comparing said plurality of service packets and the order in which said service packets are received by said recording means against a predetermined ordering of service packets relating to said transaction.

14. The non-intrusive system as claimed in Claim 12, wherein said recording means is located on a portion of  
15 said communications line between said source and destination nodes.

15. A method for identifying a transaction corresponding to a plurality of service packets  
20 communicated between a source node and a destination node, comprising:

providing a communications data set comprising (i) a plurality of service packets corresponding to a plurality of service requests and (ii) the start and stop times for  
25 each service request; and

comparing the time interval between the stop of a first service request and the start of a second service request against a predetermined value for said time

-38-

interval to identify a sequence of said service requests corresponding to a transaction.

16. The method as claimed in Claim 15, wherein said predetermined value ranges from about 50 to about 500  
5 milliseconds.

17. The method as claimed in Claim 15, wherein a portion of said service packets correspond to a thread and at least two service packets correspond to different threads and said service packets comprise a plurality of  
10 service request packets and service result packets corresponding to different service requests and said comparing step comprises:

identifying service request packets in said service packets;

15 correlating service result packets with corresponding service request packets to form a plurality of service data subsets with the service packets in each service data subset corresponding to a service request; and

20 sorting said service data subsets by thread to form a plurality of thread data sets of service requests with the service packets in said thread data set having the same thread addresses.

18. The method as claimed in Claim 15, wherein a plurality of sequences of service requests correspond to a  
25 plurality of transactions and said comparing step comprises:



-39-

recording each of said sequences of service requests and the number of occurrences of each sequence in a pattern characterization data set.

19. The method as claimed in Claim 15, further  
5 comprising:

selecting a second predetermined value;

comparing said time interval against said second predetermined value to identify a second sequence of said service requests corresponding to a second transaction; and

10 recording each of said second sequences of service requests and the number of occurrences of each of said second sequences in a second data set.

20. The method as claimed in Claim 19, further comprising:

15 selecting a third predetermined value based on the relationship between (i) the number of said sequences of service requests and said predetermined value and (ii) the number of said second sequences of service requests and said second predetermined value.

20 21. The method as claimed in Claim 20, further comprising:

comparing said time interval against said third predetermined value for said time interval to identify a third sequence of said service requests corresponding to a  
25 third transaction.

-40-

22. The method as claimed in Claim 21, further comprising:

5 comparing said third sequence against said communications data set to determine whether at least a portion of said plurality of service packets correspond to said transaction.

23. The method as claimed in Claim 22, further comprising:

10 computing a response time for said transaction.

24. The method as claimed in Claim 15, wherein said comparing step produces a pattern characterization data set listing a plurality of sequences of service requests and further comprising:

15 second comparing said service requests from said comparing step with said pattern characterization data set to determine if said service requests are contained in said pattern characterization data set.

25. The method as claimed in Claim 15, wherein said first service request corresponds to a first thread and said second service request corresponds to a second thread.

26. A non-intrusive system for determining transaction level activity between a source node and a destination node, comprising:

25 means for recording a plurality of service packets communicated on a communications line between a source node and a destination node, wherein said service packets relate to a number of transactions and said recording means is in communication with said communications line; and

-41-

means for determining said number of transactions in communication with said recording means.

27. The non-intrusive system as claimed in Claim 26, wherein said determining means comprises means for  
5 comparing said plurality of service packets and the order in which said service packets are received by said recording means against a predetermined ordering of service packets relating to said transaction.

28. The non-intrusive system as claimed in Claim 26,  
10 wherein at least a portion of said plurality of packets relate to different service request packets, said recording means provides a first data set including (i) said plurality of packets and (ii) the start and stop times for each service request, and said determining means comprises  
15 means for comparing the time interval between the stop time of a first service request and the start time of a second service request against a predetermined value for said time interval to identify a sequence of said service requests corresponding to a transaction.

1 / 17

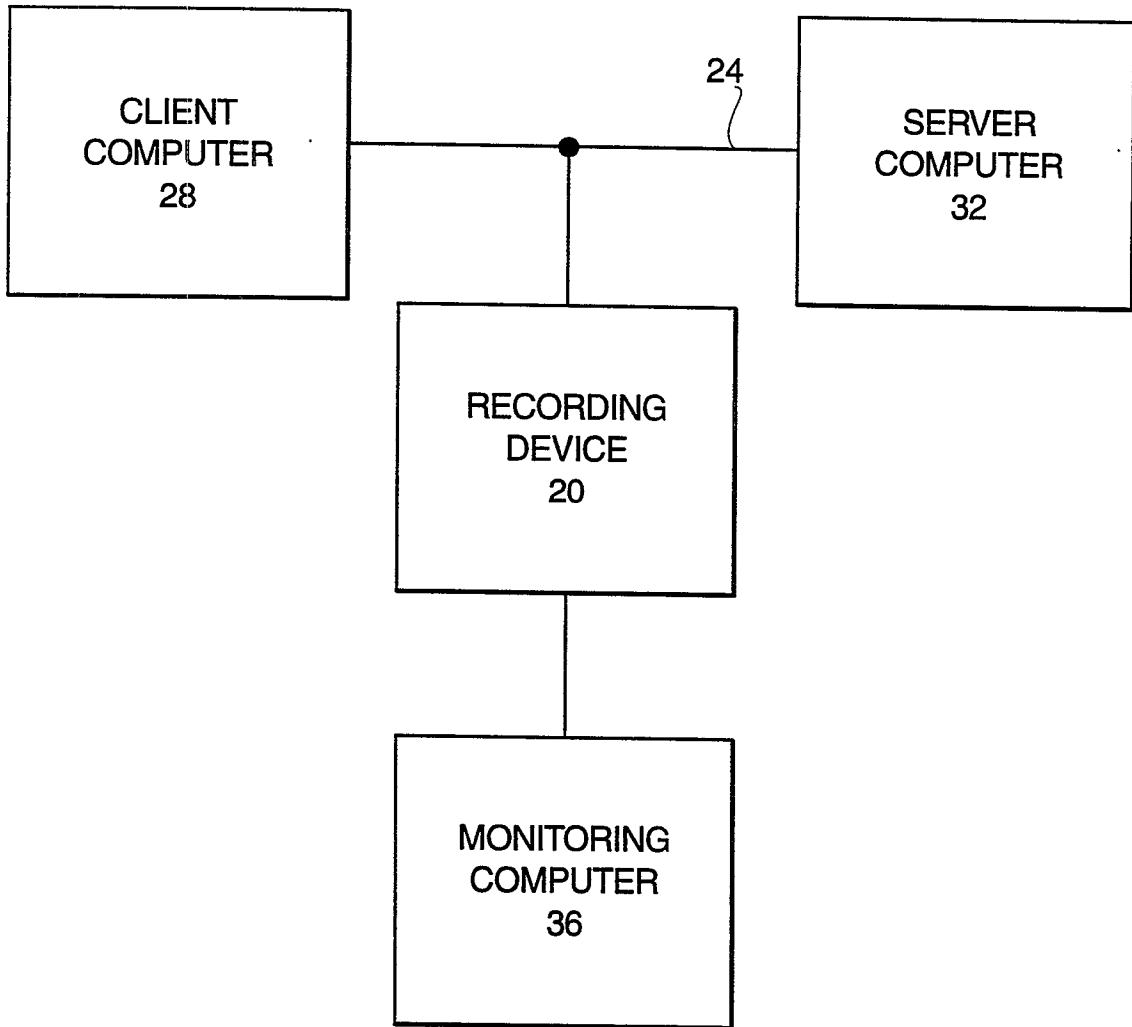

Fig. 1

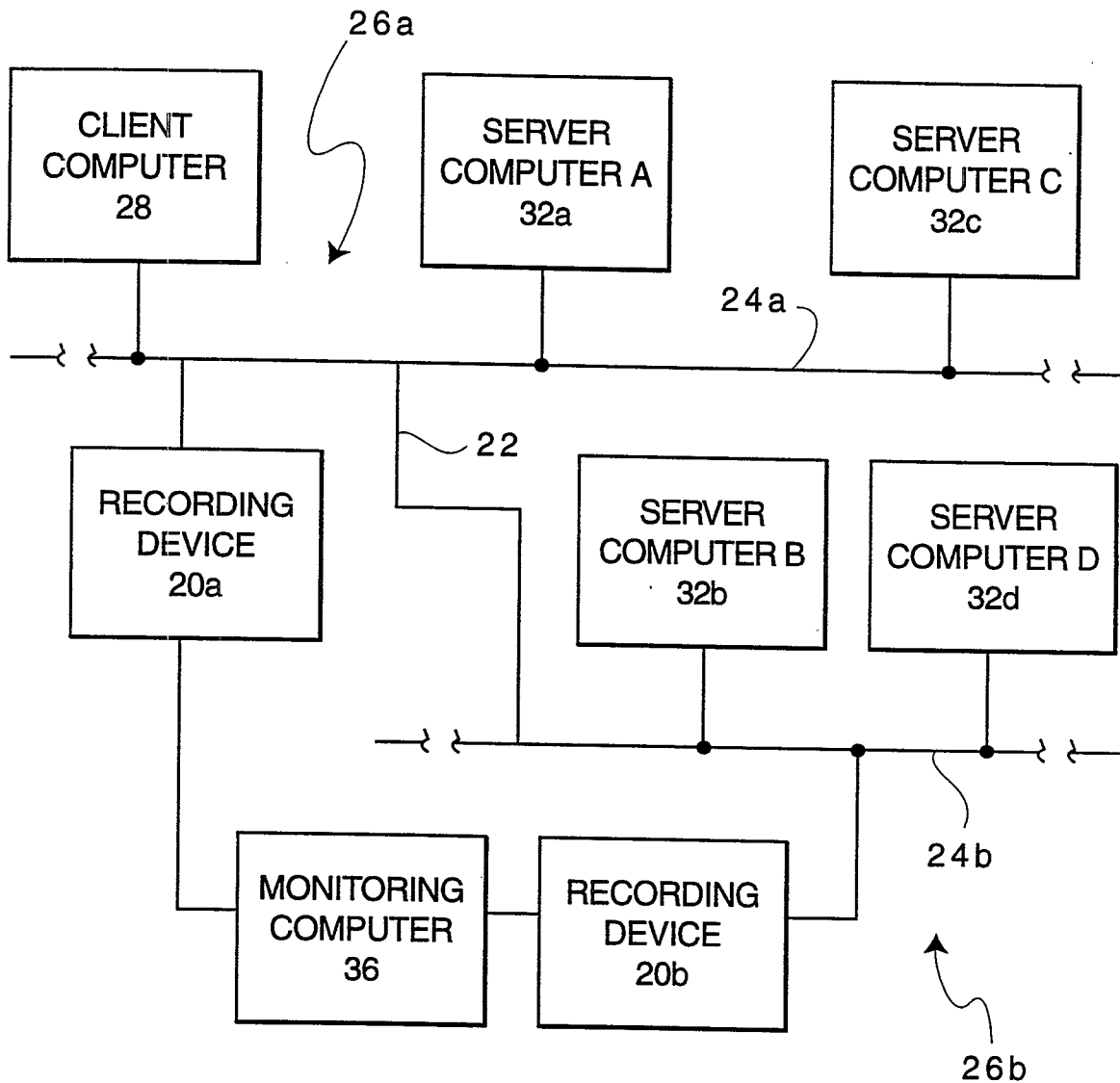

Fig. 2

3 / 1 7

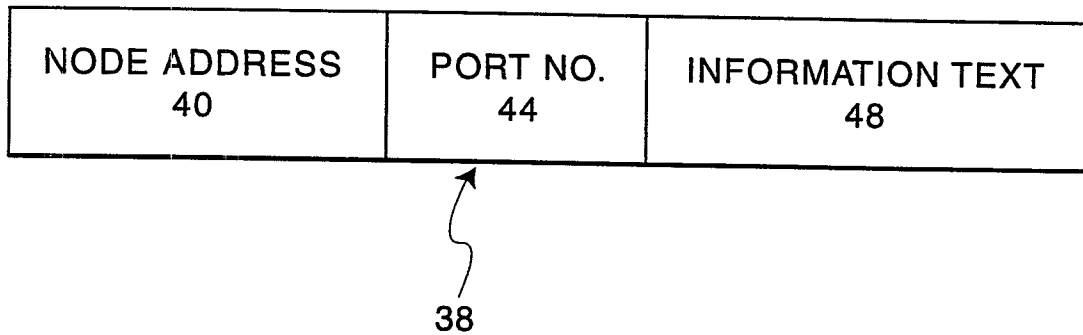

Fig. 3

4 / 17

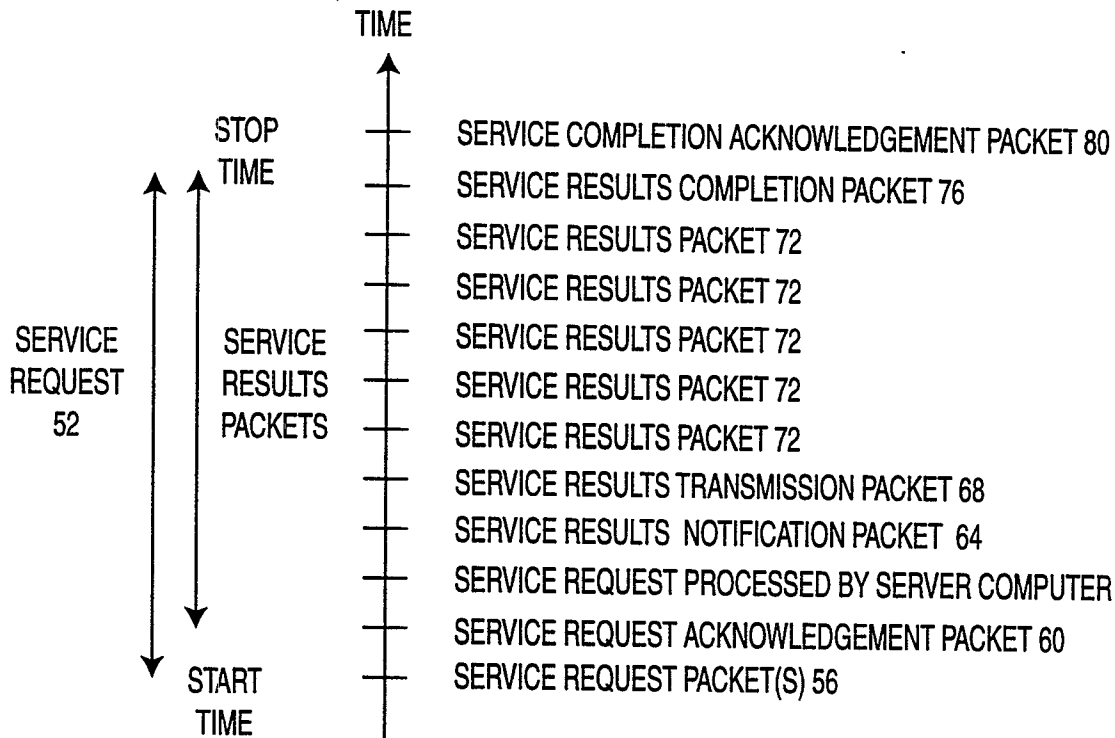

Fig. 4

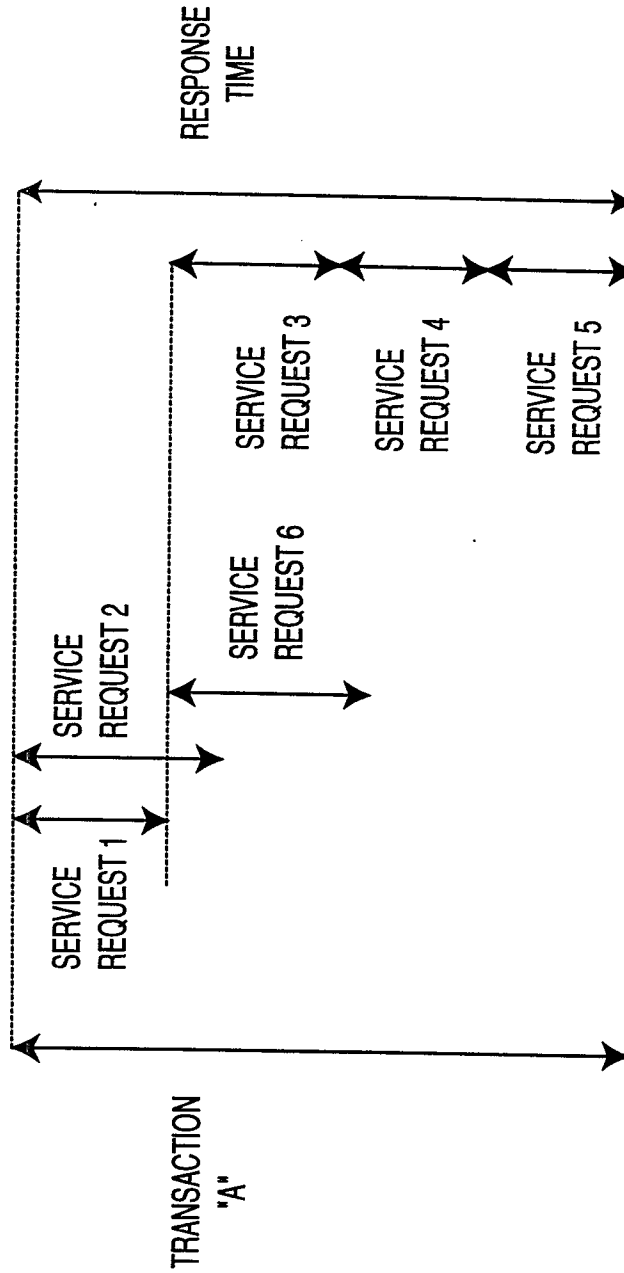

Fig. 5



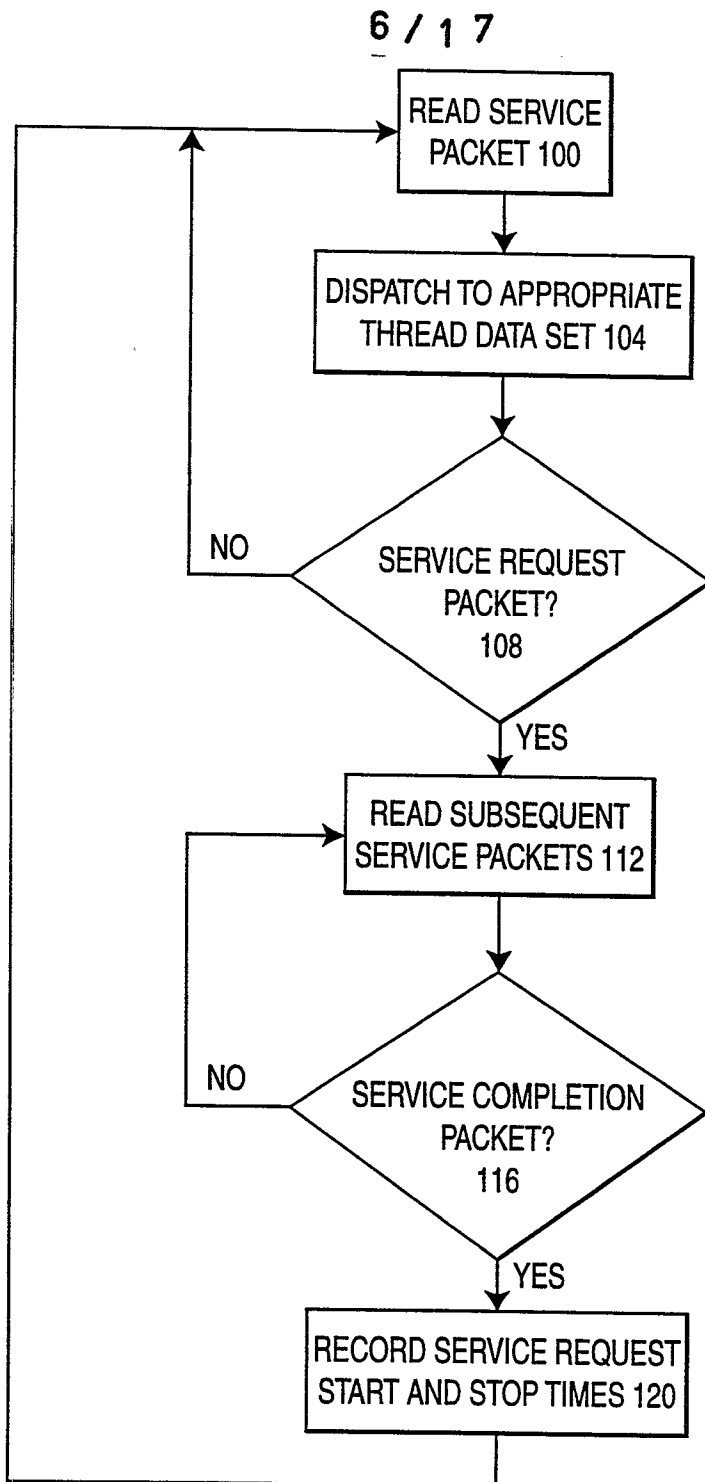

Fig. 6A

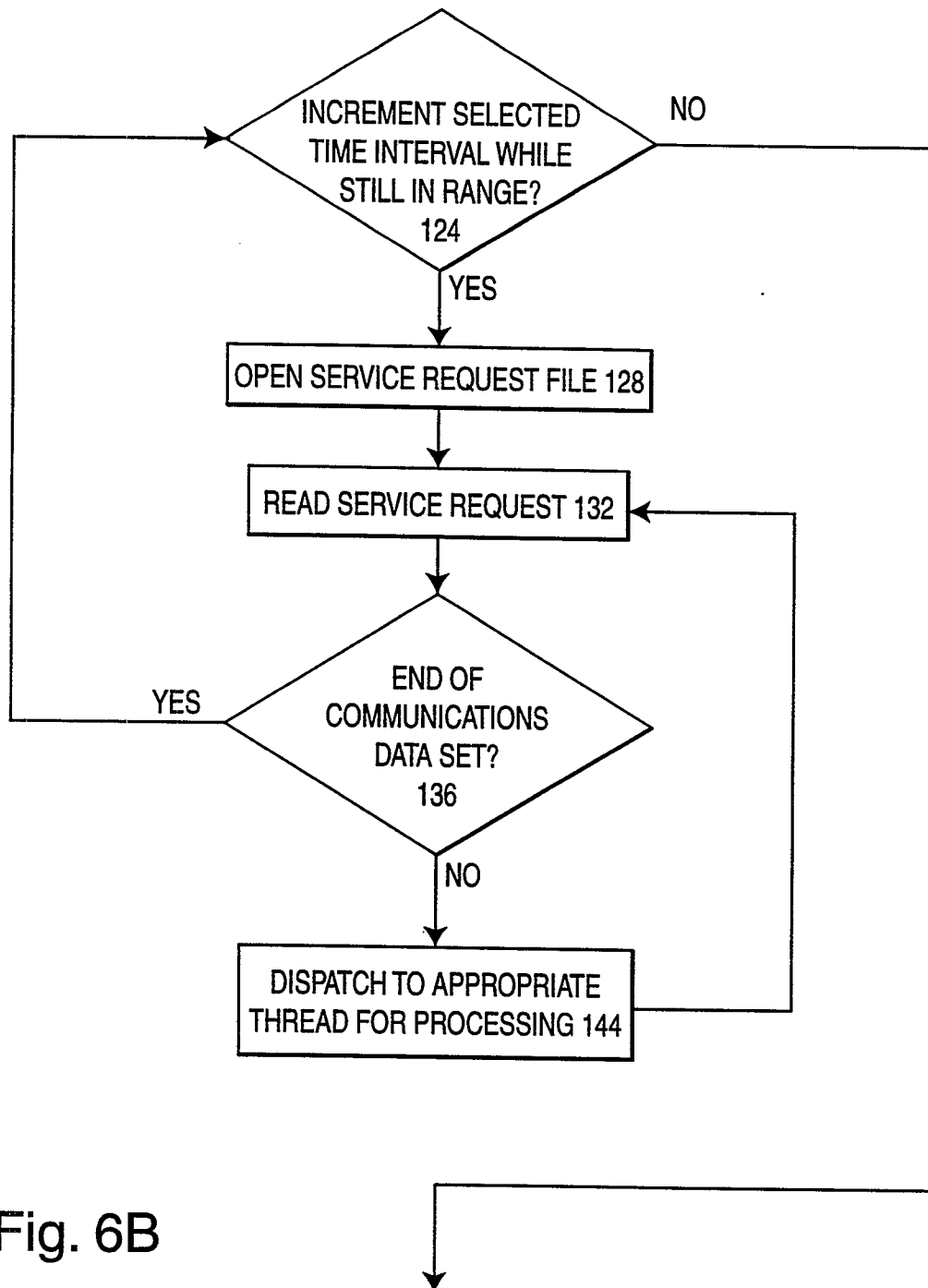

Fig. 6B

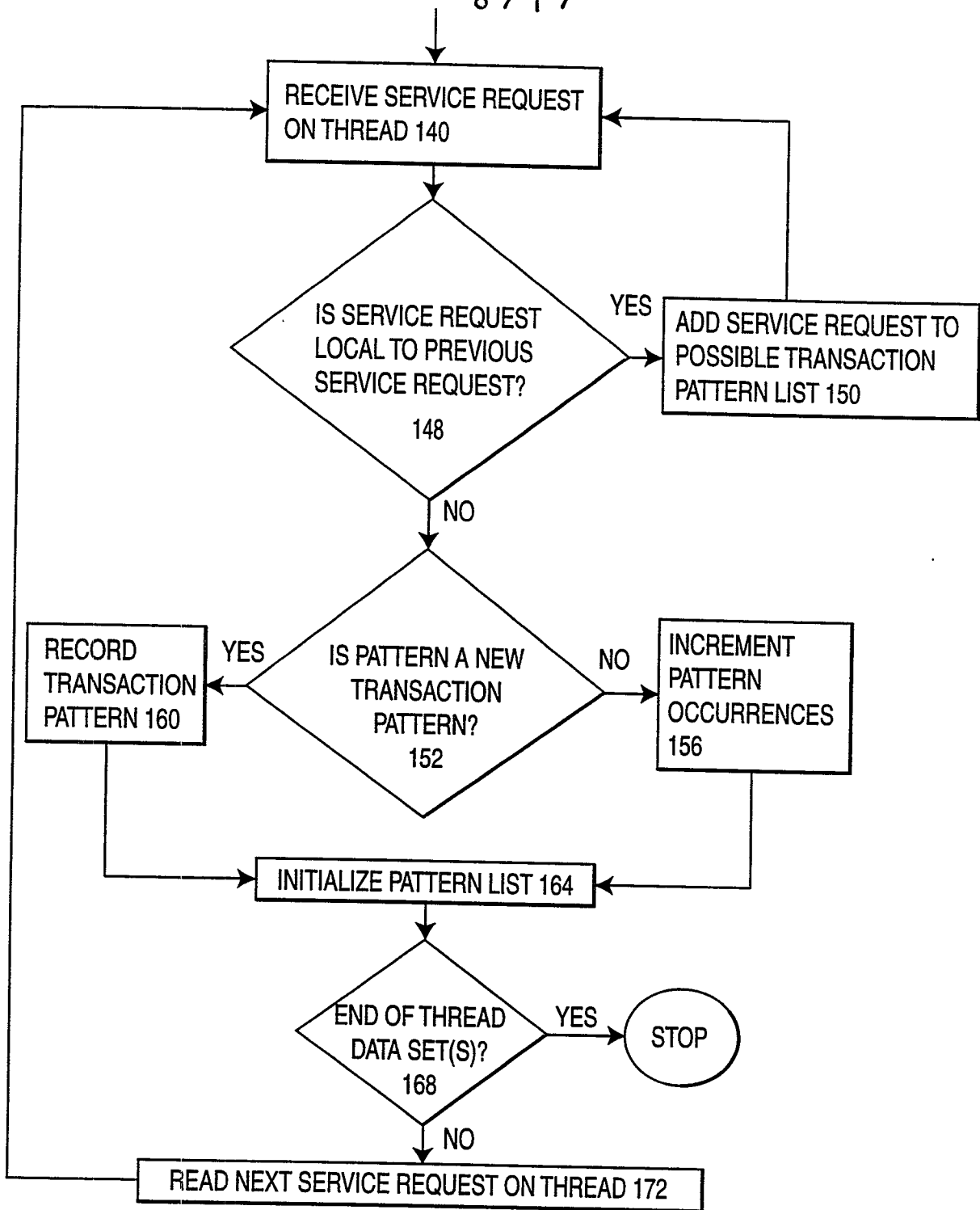

Fig. 6C

9 / 17

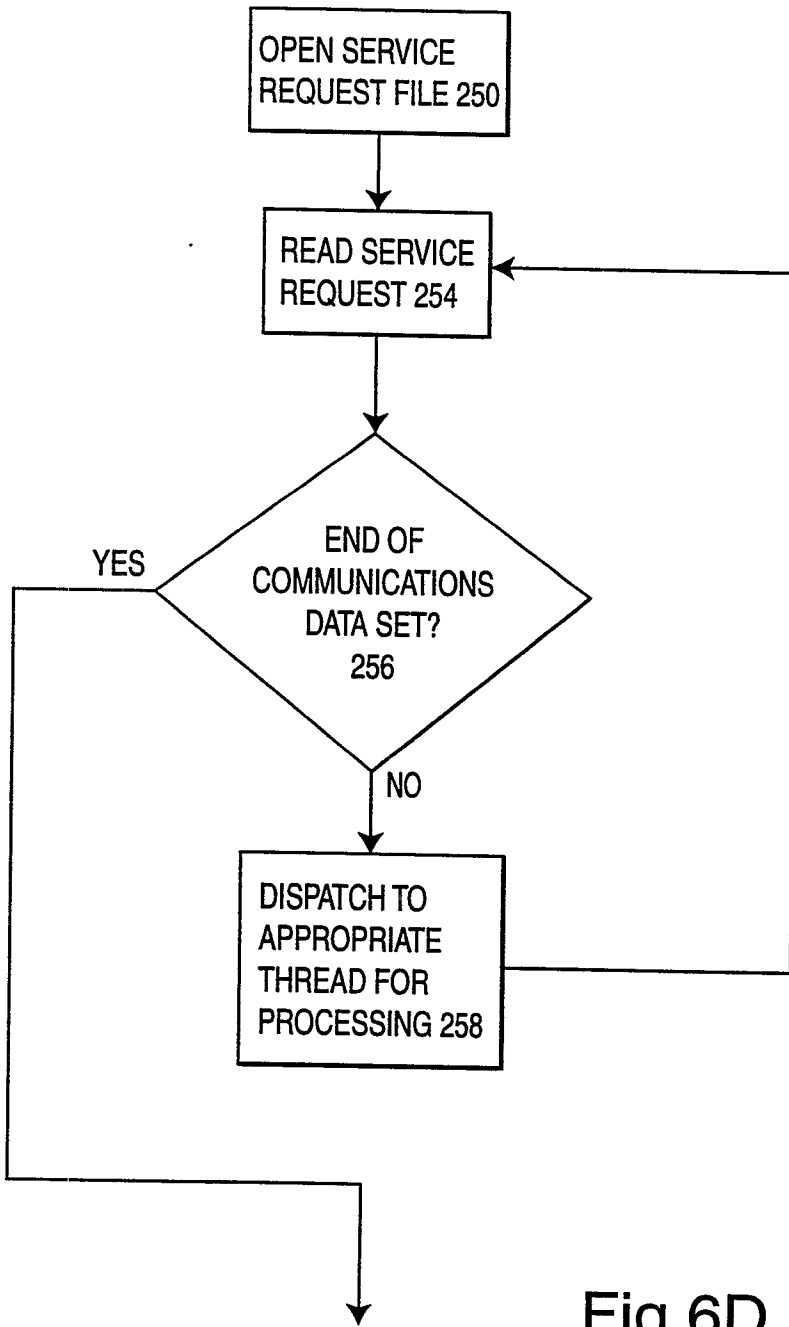

Fig 6D

10/17

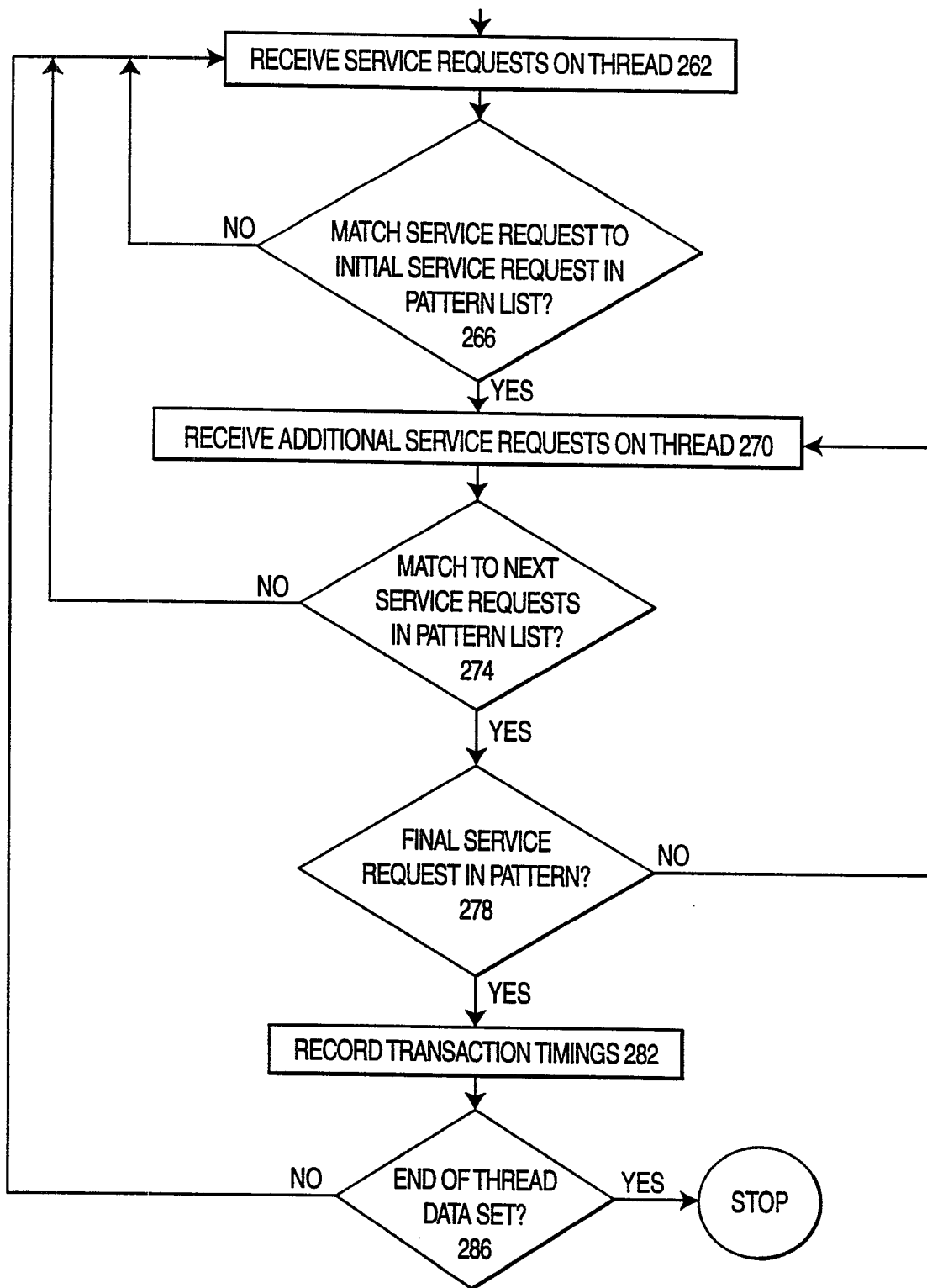

Fig.6E

11/17

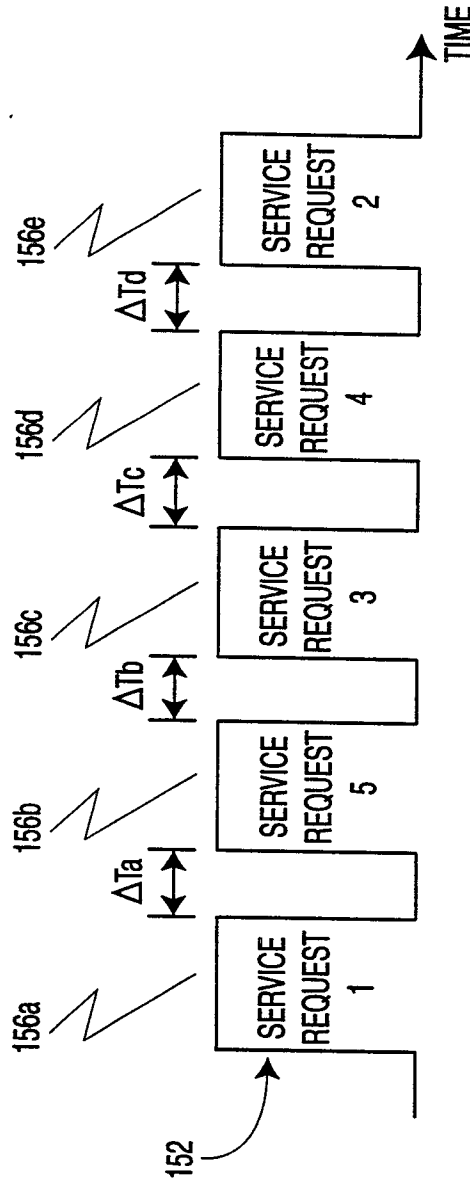

Fig. 7

12/17

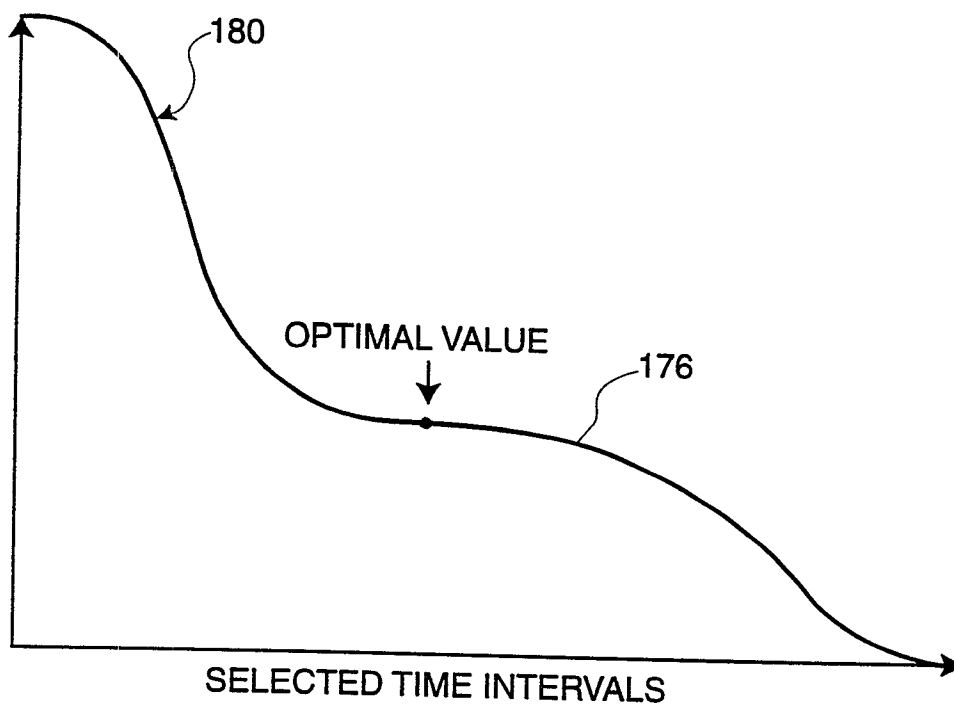

Fig. 8

13/17

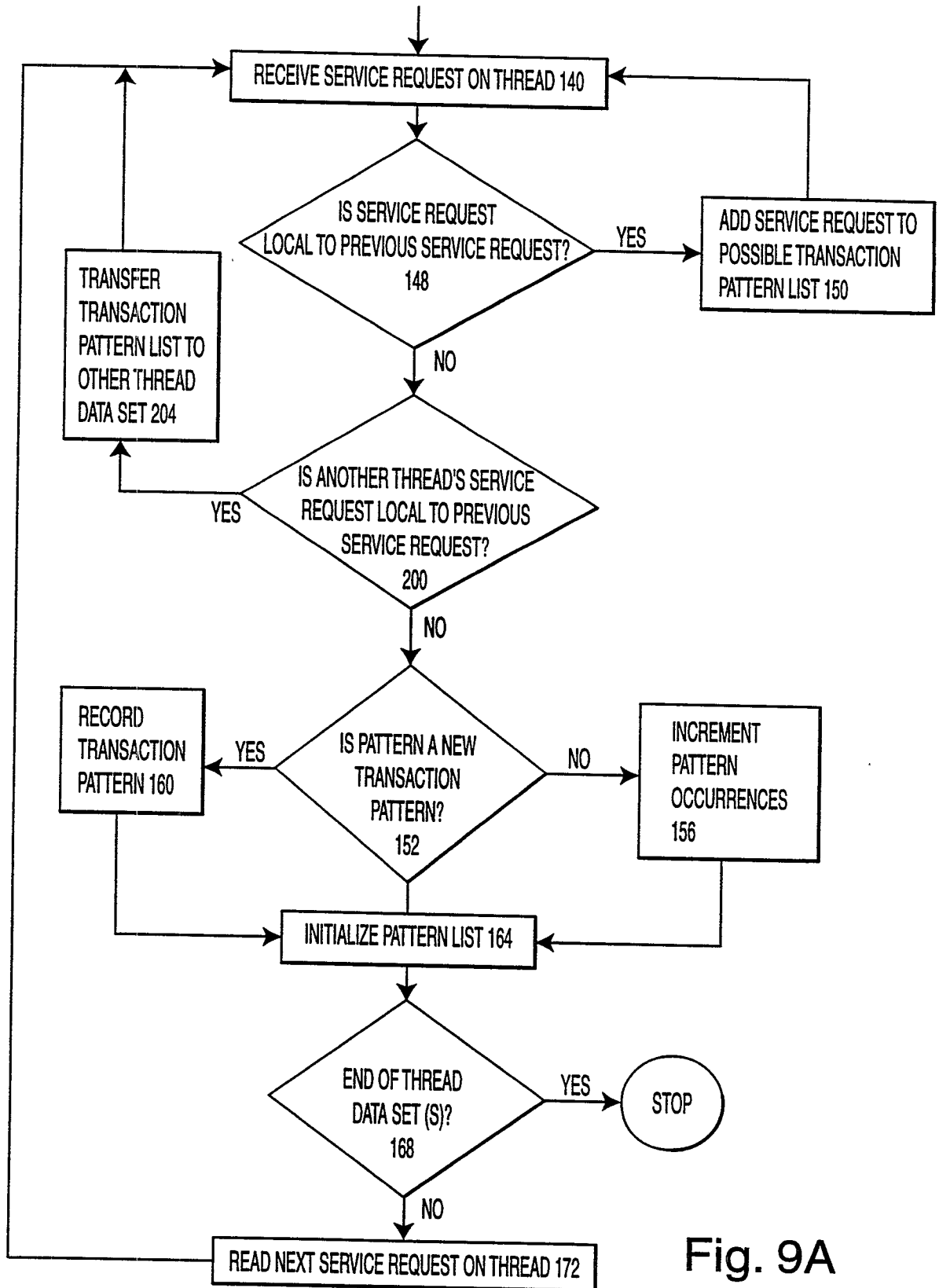

Fig. 9A



14/17

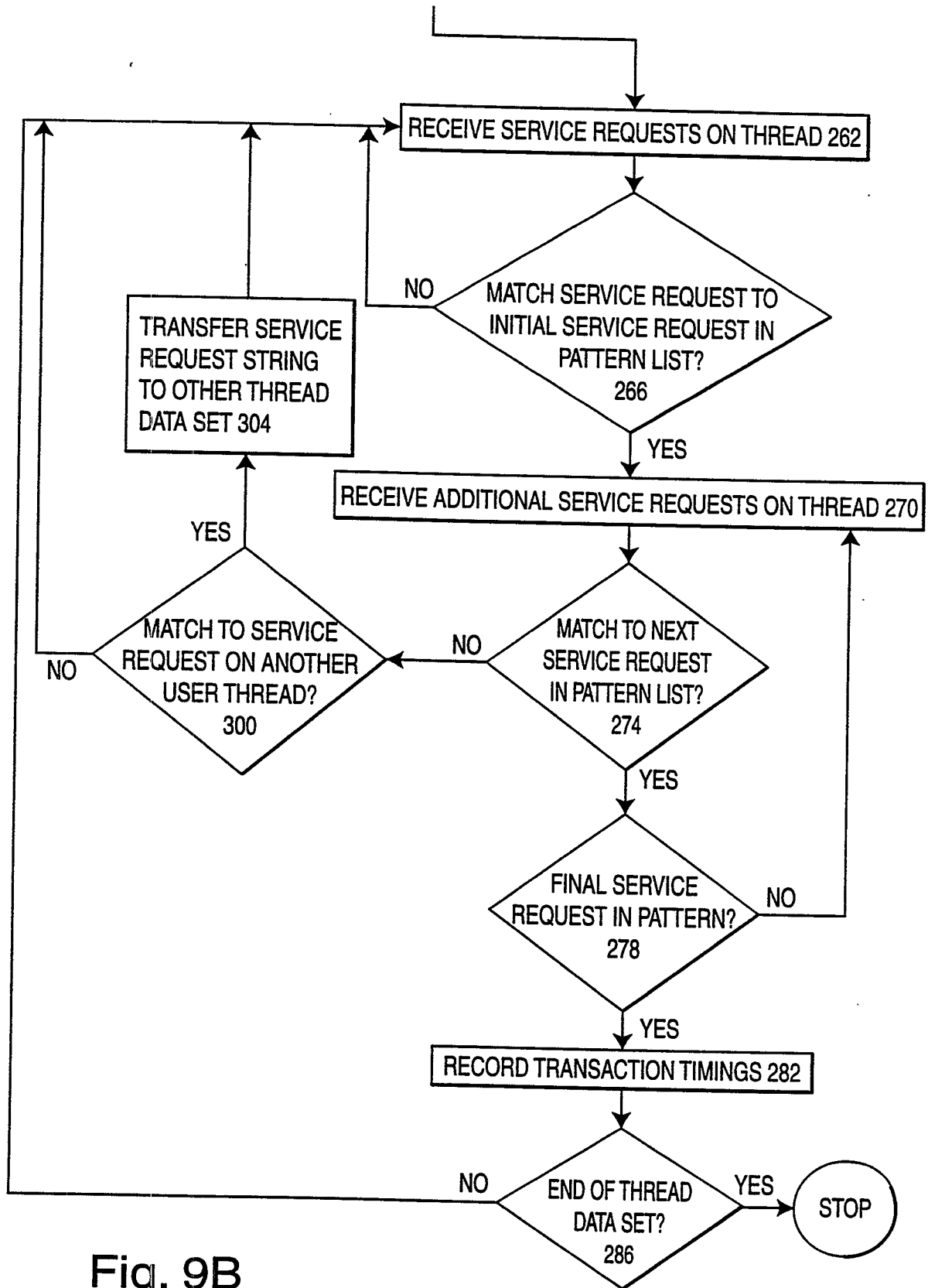

Fig. 9B

15/17

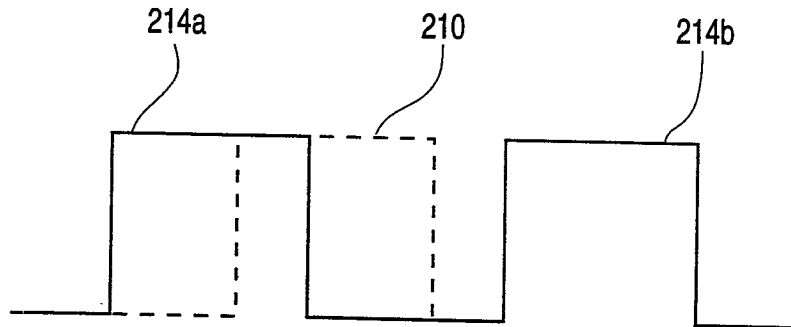

Fig. 10

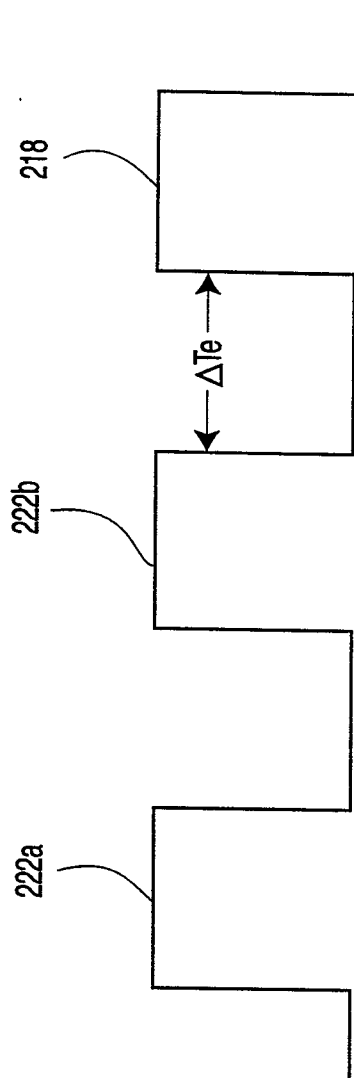

Fig. 11

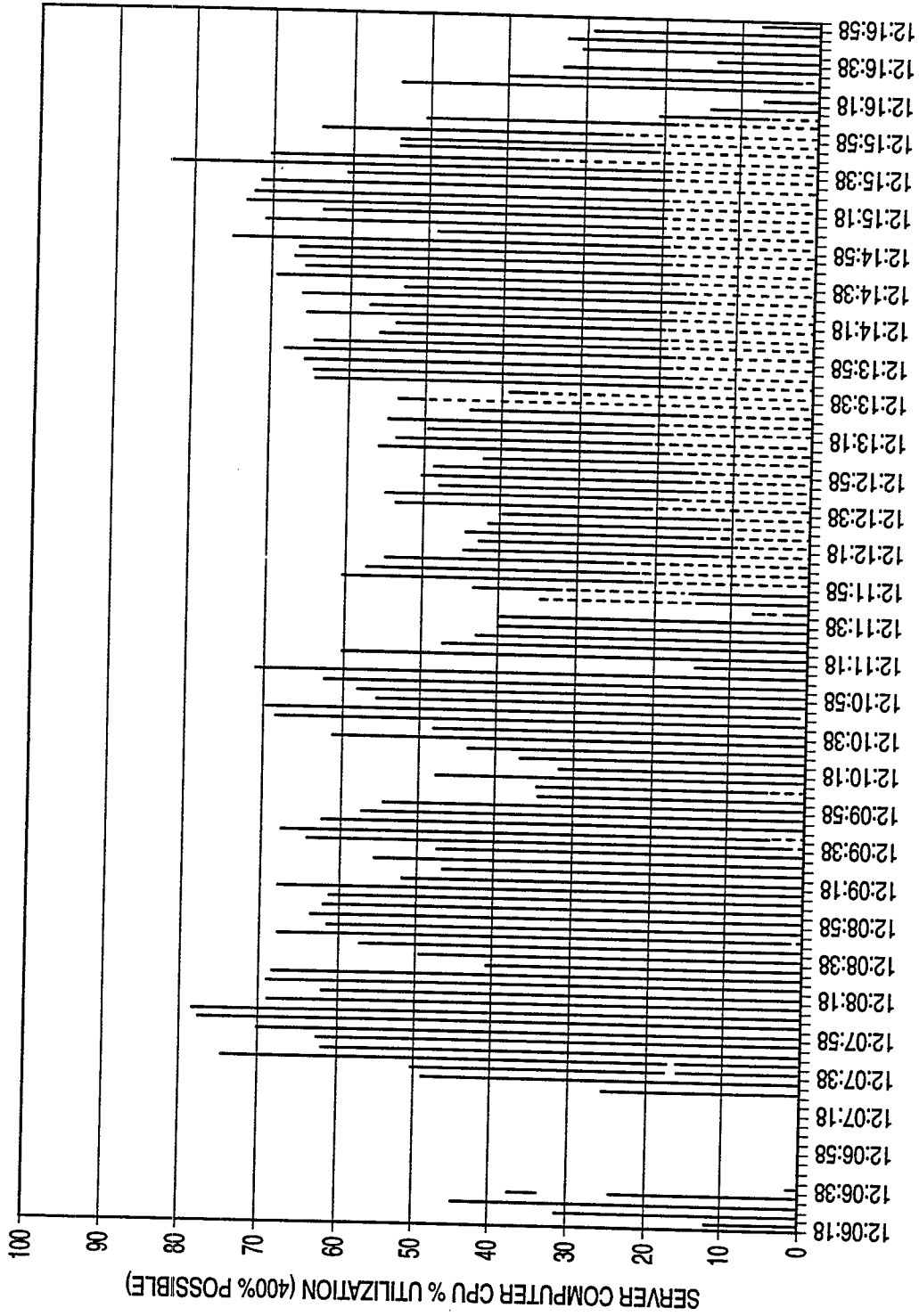

Fig. 12

Time in 5 Second Intervals

TRANSACTION RESPONSE TIME

(SUBSTITUTE SHEET (RULE 26))

