

C. D. BIGELOW.  
CONGRESS-GAITERS.

No. 177,455.

Patented May 16, 1876.

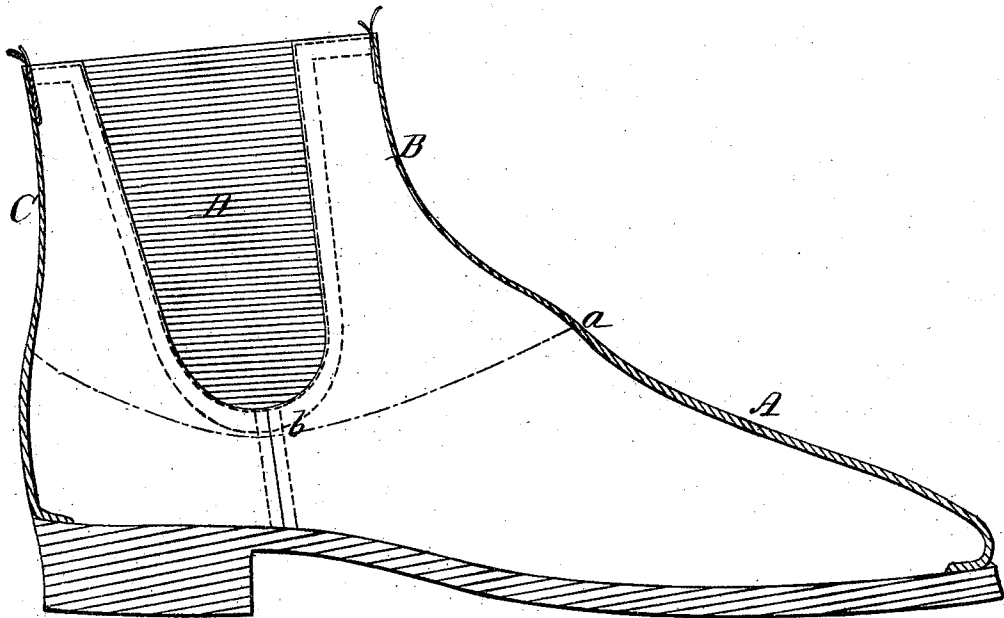
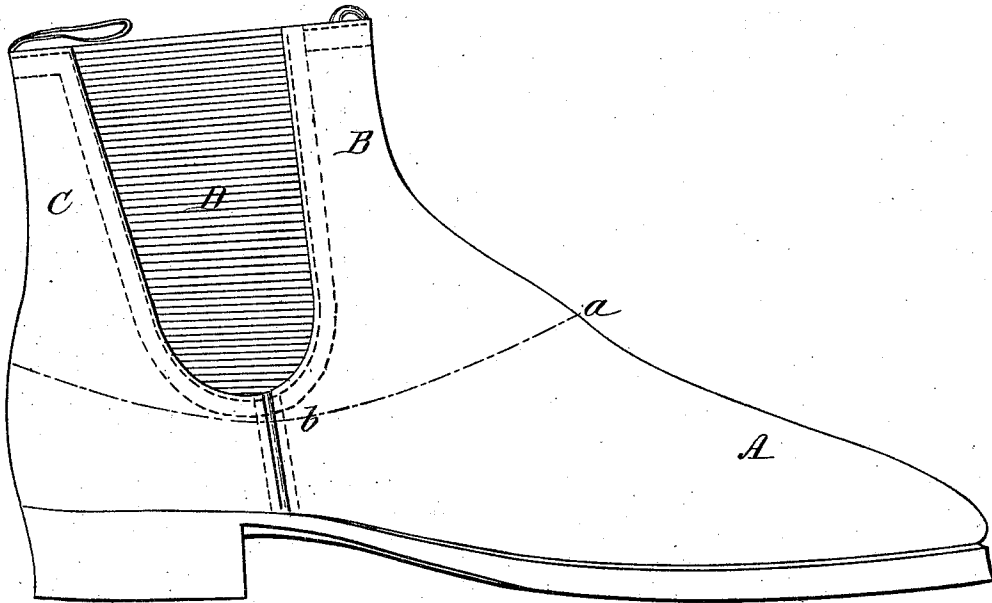

Witnesses:  
J. H. Wagner  
J. H. Rutherford

Inventor:  
Chas. D. Bigelow  
124 Johnson & Johnson  
Attys

# UNITED STATES PATENT OFFICE.

CHARLES D. BIGELOW, OF BROOKLYN, NEW YORK, ASSIGNOR TO BAY STATE SHOE AND LEATHER COMPANY, OF NEW YORK CITY.

## IMPROVEMENT IN CONGRESS-GAITERS.

Specification forming part of Letters Patent No. **177,455**, dated May 16, 1876; application filed March 16, 1876.

*To all whom it may concern:*

Be it known that I, CHARLES D. BIGELOW, of Brooklyn, in the county of Kings and State of New York, have invented certain new and useful Improvements in the Manufacture of Boots and Shoes, of which the following is a specification:

In making what is known as a "Creole congress-gaiter," the front is cut in one piece to form the instep and leg, and the shoe thus made, if of heavy leather for working-men, renders the top or leg portion, and at the bend of the instep, so stubborn and unpleasant to the wearer that heavy goods of this kind have not been extensively manufactured, although the style of shoe is a very desirable one, as it avoids the necessity of cutting a separate topping-piece of thin material, and stitching it to the front or vamp, and thereby making several seams that are liable to rip, in order to get a soft top. A serious objection to a Creole congress-gaiter is the stubbornness of the top and the instep, which not only hurts the wearer, but tends to destroy the elastic goring, and to avoid this objection I reduce the leather in thickness from about a little below the base of the gore on the side and the instep in the front to the top of the leg, of both the back and the front, and obtain thereby a thin and pliable top, leaving the balance of the upper, which bears the principal wear of the shoe, the full thickness. The top part is left of sufficient thickness to sustain the stitching which unites the elastic gore to the front and back. The front and heel can be made in one piece, if desired, but I prefer to make the front and back in separate pieces, and unite them by side seams, in the usual manner, as a more perfect fit in this way can be obtained.

The reduction of the thickness of the leather at the points stated is made by splitting or shaving off the inner surface before crimping, as it is necessary that the reduction be uniform.

The reduction in the thickness of the upper portion of the upper allows it to be more easily crimped, while it gives the additional important advantage of preventing the goring from being destroyed, as it would be, by a heavy thick upper.

The drawings show, in elevation and section, a Creole congress-gaiter embracing my invention, and in which A is the front or vamp of thick leather; B, the topping-piece or leg, made thin or reduced from a point, *a*, below the instep, to a point, *b*, below the base of the goring, and integral with the vamp. The back C is also reduced in thickness in the same manner and at points corresponding to the vamp, and to these integrally-reduced portions the elastic goring D is secured with the same advantage as if stitched to separate thin topping-pieces, as heretofore. The extension of the reduced portion beneath the goring is to obtain the benefit of stitching it all round to material that will yield with the goring and not cut it out.

I claim—

1. A leather congress-gaiter, having its upper portion reduced in thickness, as and for the purpose stated.

2. A congress-gaiter, having a thick foot-portion with the upper or ankle portion integral therewith, reduced by skiving or splitting, substantially as and for the purpose stated.

3. In a congress-gaiter, the combination, with upper having its foot portion of the full thickness of the leather, and the upper or ankle portion reduced in thickness, and forming an integral part of the foot portion of an elastic goring.

In testimony whereof I have affixed my signature in the presence of two witnesses.

CHAS. D. BIGELOW.

Witnesses:

A. E. H. JOHNSON,  
J. W. HAMILTON JOHNSON.