



US00D623702S

(12) **United States Design Patent**  
**Dalgaard et al.**

(10) **Patent No.:** **US D623,702 S**

(45) **Date of Patent:** **\*\* Sep. 14, 2010**

(54) **CASTER SCOOTER**

(75) Inventors: **Martin Dalgaard**, Topanga, CA (US);  
**James Ibon**, Porter Ranch, CA (US)

(73) Assignee: **Jasun Weiner**, Laguna Beach, CA (US)

(\*\*) Term: **14 Years**

(21) Appl. No.: **29/345,597**

(22) Filed: **Oct. 19, 2009**

(51) **LOC (9) Cl.** ..... **21-01**

(52) **U.S. Cl.** ..... **D21/423; D21/771**

(58) **Field of Classification Search** ..... D21/419,  
D21/421, 423, 426, 769, 760, 765, 771, 803;  
D12/1, 8; 280/14.21, 14.25, 14.26, 87.041,  
280/87.042, 263, 288.1, 288.2, 288.4, 200,  
280/214, 809; 180/180, 181

See application file for complete search history.

(56) **References Cited**

**U.S. PATENT DOCUMENTS**

|                   |         |                 |       |            |
|-------------------|---------|-----------------|-------|------------|
| D399,902 S *      | 10/1998 | Lee             | ..... | D21/765    |
| D418,567 S *      | 1/2000  | Robinette       | ..... | D21/760    |
| 6,481,913 B2      | 11/2002 | Chen            |       |            |
| D470,898 S *      | 2/2003  | Chen            | ..... | D21/423    |
| D479,734 S *      | 9/2003  | Schaffer et al. | ..... | D21/423    |
| D516,132 S        | 2/2006  | Sramek          |       |            |
| D552,201 S *      | 10/2007 | Kwak            | ..... | D21/765    |
| 7,338,056 B2      | 3/2008  | Chen et al.     |       |            |
| D569,448 S        | 5/2008  | Sramek et al.   |       |            |
| 7,367,572 B2 *    | 5/2008  | Jiang           | ..... | 280/87.042 |
| D572,332 S *      | 7/2008  | Sramek et al.   | ..... | D21/765    |
| D575,352 S        | 8/2008  | Sramek et al.   |       |            |
| D583,006 S *      | 12/2008 | Hennings, III   | ..... | D21/803    |
| 7,600,768 B2      | 10/2009 | Chen et al.     |       |            |
| 2002/0067018 A1   | 6/2002  | Shaw            |       |            |
| 2002/0105157 A1 * | 8/2002  | Chen            | ..... | 280/87.041 |

|                   |         |             |       |            |
|-------------------|---------|-------------|-------|------------|
| 2006/0055137 A1 * | 3/2006  | Jiang       | ..... | 280/87.042 |
| 2006/0163830 A1 * | 7/2006  | Kwak        | ..... | 280/87.042 |
| 2007/0001414 A1 * | 1/2007  | Kang        | ..... | 280/87.041 |
| 2007/0273118 A1   | 11/2007 | Conrad      |       |            |
| 2009/0058028 A1 * | 3/2009  | Chen et al. | ..... | 280/87.042 |

**OTHER PUBLICATIONS**

Street Surfing LLC; The Wave Owner's Manual; 2005; 4 pages.  
Razor USA LLC; Razor Kick Scooter Owner's Manual: A-Type, Cruiser & ProModel Scooter; 2007; 6 pages.  
Razor USA LLC; Ripstick Caster Board Owner's Manual; Revision: Jan. 25, 2008; 4 pages.

\* cited by examiner

*Primary Examiner*—Cynthia M Chin

(74) *Attorney, Agent, or Firm*—Mind Law Firm, P.C.;  
Jeromye V. Sartain; Justin G. Sanders

(57) **CLAIM**

The ornamental design for caster scooter, as shown and described.

**DESCRIPTION**

FIG. 1 is a perspective view of a scooter showing the new design;

FIG. 2 is a top plan view of the scooter of FIG. 1;

FIG. 3 is a bottom plan view of the scooter of FIG. 1;

FIG. 4 is a side elevational view of the scooter of FIG. 1;

FIG. 5 is another side elevational view of the scooter of FIG. 1;

FIG. 6 is a front elevational view of the scooter of FIG. 1; and,

FIG. 7 is a rear elevational view of the scooter of FIG. 1.

The broken lines represent portions of the design and the environment in which it resides and forms no part of the claim.

**1 Claim, 6 Drawing Sheets**

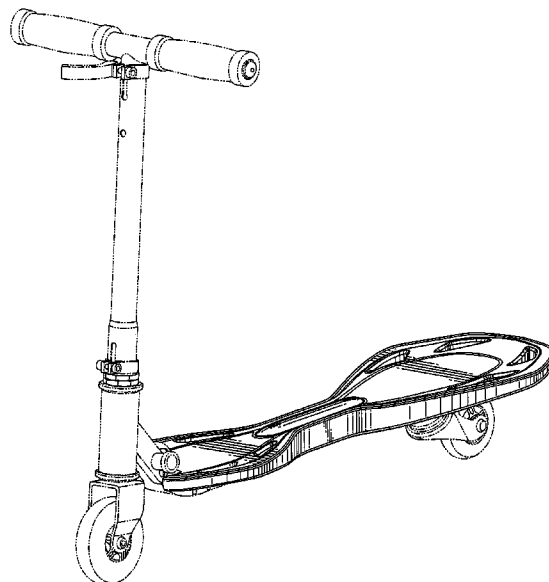
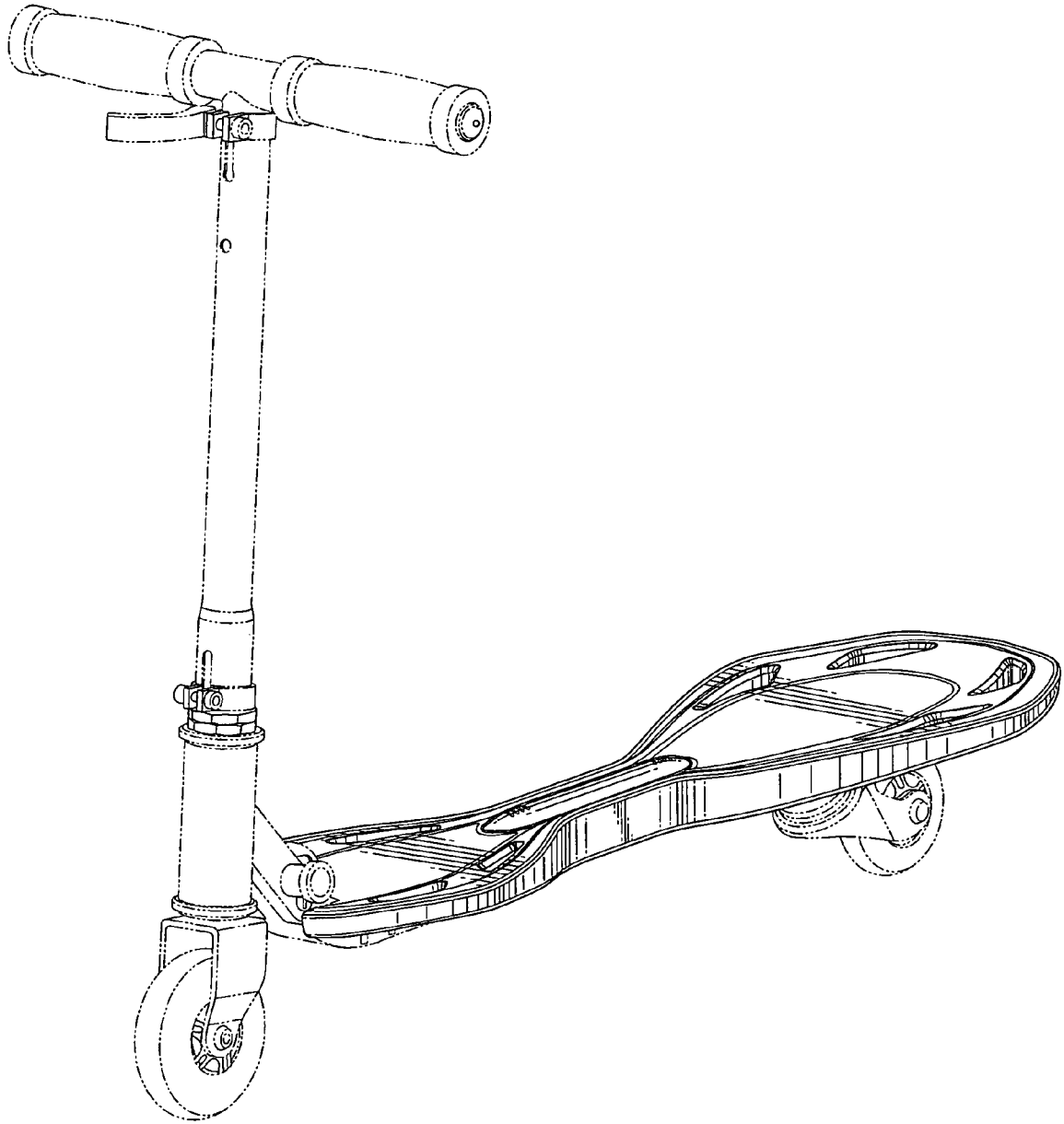

FIG. 1



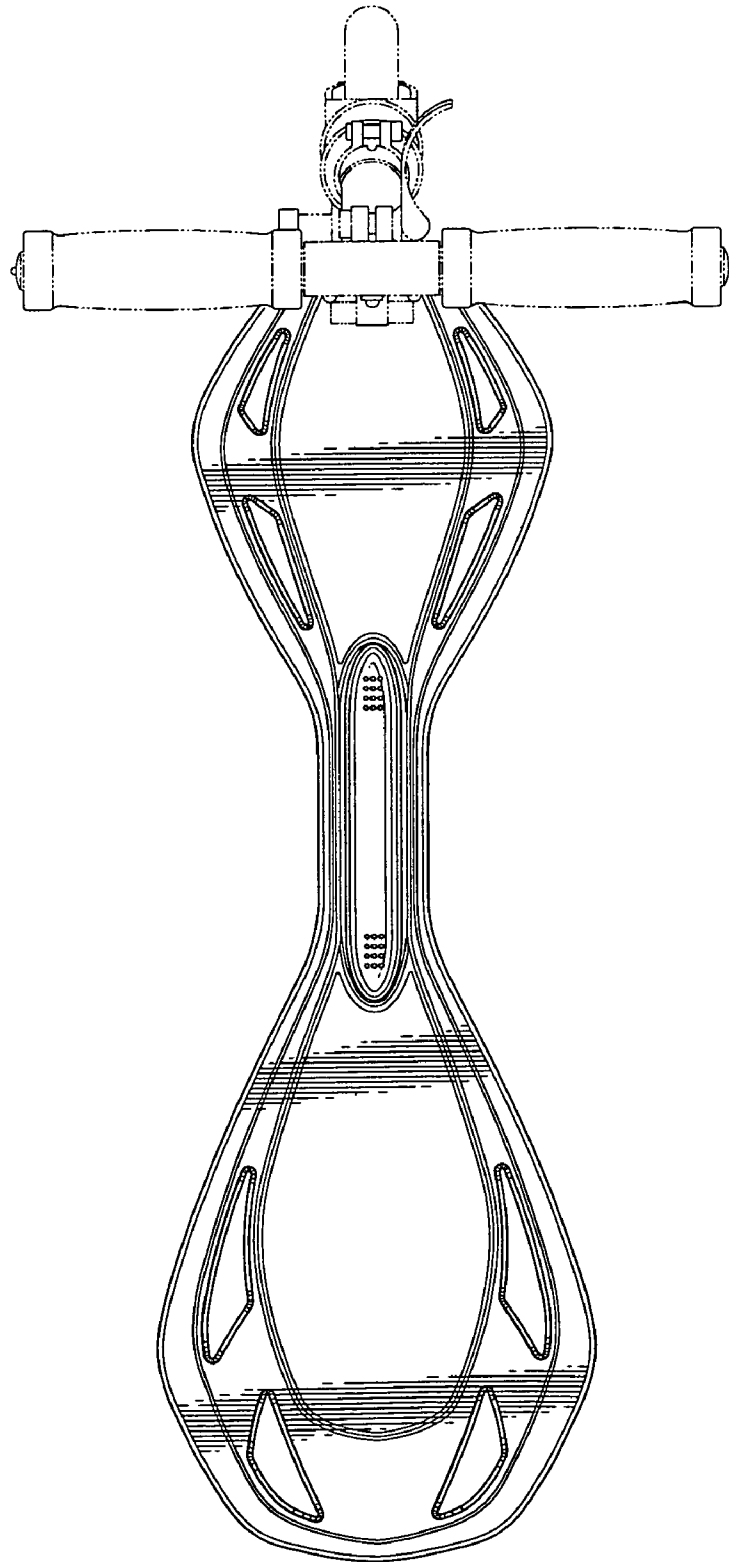

FIG. 2

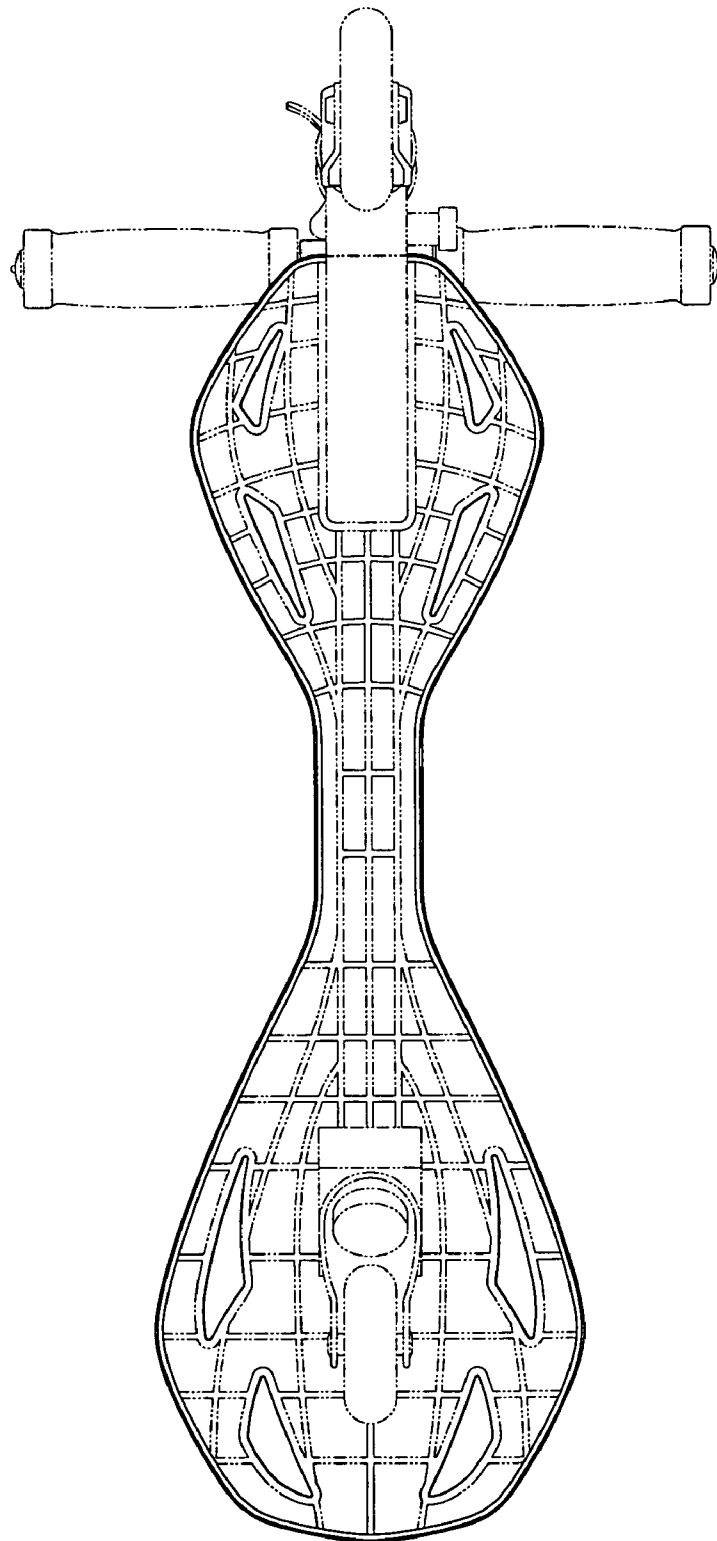

FIG. 3

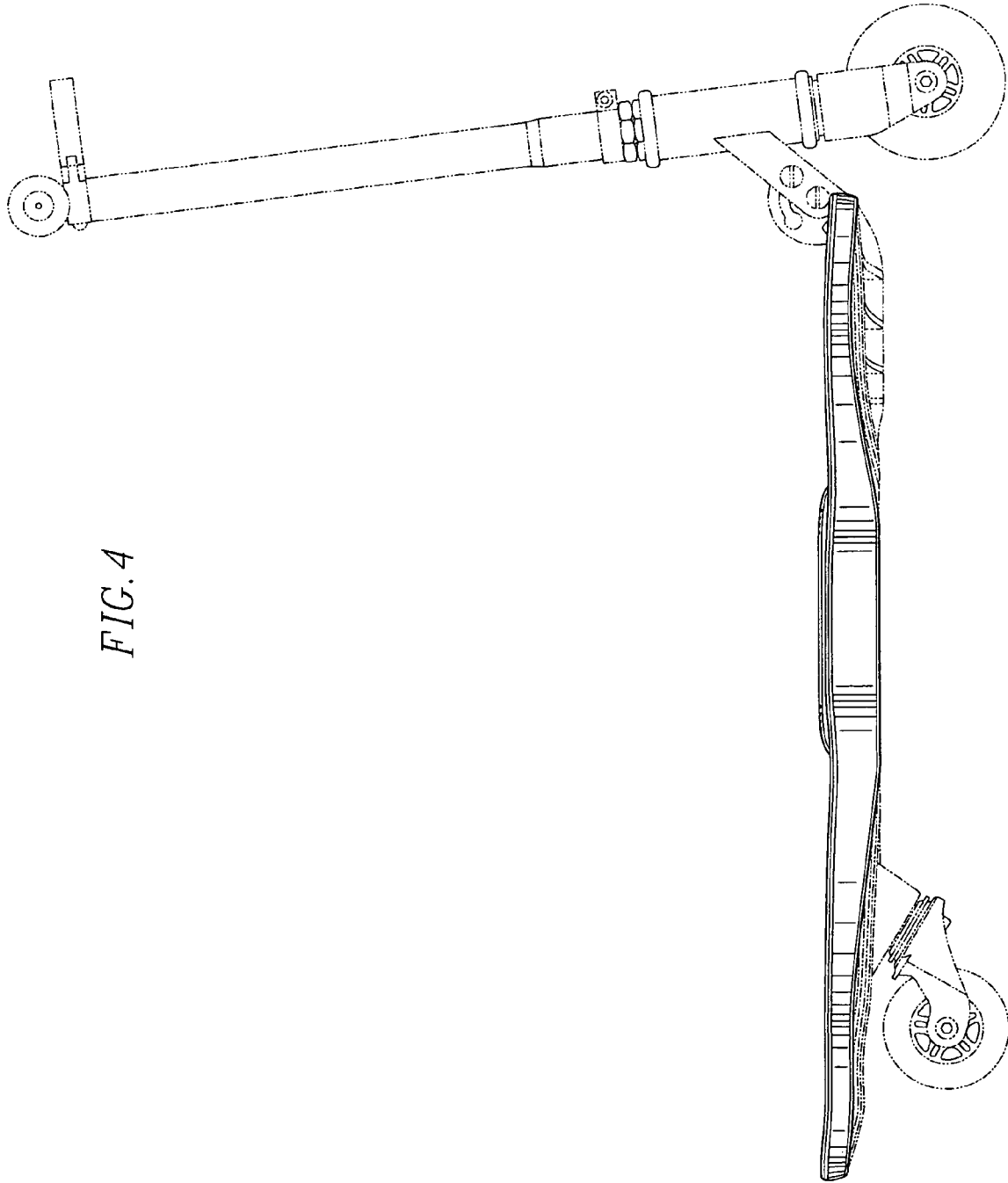

FIG. 4

