

(19) World Intellectual Property
Organization
International Bureau



(43) International Publication Date
29 December 2004 (29.12.2004)

PCT

(10) International Publication Number
WO 2004/113200 A1

- (51) International Patent Classification⁷: B65D 83/04, A61J 1/03
- (21) International Application Number: PCT/US2004/018257
- (22) International Filing Date: 9 June 2004 (09.06.2004)
- (25) Filing Language: English
- (26) Publication Language: English
- (30) Priority Data: 60/477,485 9 June 2003 (09.06.2003) US
- (71) Applicant (for all designated States except US): MEAD-WESTVACO CORPORATION [US/US]; One High Ridge Park, Stamford, CT 06905 (US).
- (72) Inventor; and
- (75) Inventor/Applicant (for US only): GELARDI, John, A. [US/US]; P.O. BOX 714, Rocky Pasture, Kennebunkport, ME 04046 (US).
- (74) Agents: DREW, Michael, V. et al.; Meadwestvaco Corporation, 299 Park Avenue, 13th Floor, New York, NY 10171 (US).
- (81) Designated States (unless otherwise indicated, for every kind of national protection available): AE, AG, AL, AM, AT, AU, AZ, BA, BB, BG, BR, BW, BY, BZ, CA, CH, CN, CO, CR, CU, CZ, DE, DK, DM, DZ, EC, EE, EG, ES, FI, GB, GD, GE, GH, GM, HR, HU, ID, IL, IN, IS, JP, KE, KG, KP, KR, KZ, LC, LK, LR, LS, LT, LU, LV, MA, MD, MG, MK, MN, MW, MX, MZ, NA, NI, NO, NZ, OM, PG, PH, PL, PT, RO, RU, SC, SD, SE, SG, SK, SL, SY, TJ, TM, TN, TR, TT, TZ, UA, UG, US, UZ, VC, VN, YU, ZA, ZM, ZW.
- (84) Designated States (unless otherwise indicated, for every kind of regional protection available): ARIPO (BW, GH, GM, KE, LS, MW, MZ, NA, SD, SL, SZ, TZ, UG, ZM, ZW), Eurasian (AM, AZ, BY, KG, KZ, MD, RU, TJ, TM), European (AT, BE, BG, CH, CY, CZ, DE, DK, EE, ES, FI, FR, GB, GR, HU, IE, IT, LU, MC, NL, PL, PT, RO, SE, SI, SK, TR), OAPI (BF, BJ, CF, CG, CI, CM, GA, GN, GQ, GW, ML, MR, NE, SN, TD, TG).
- Published:
— with international search report

[Continued on next page]

(54) Title: A SYSTEM FOR STORING AND UNPACKING ENCASED ARTICLES

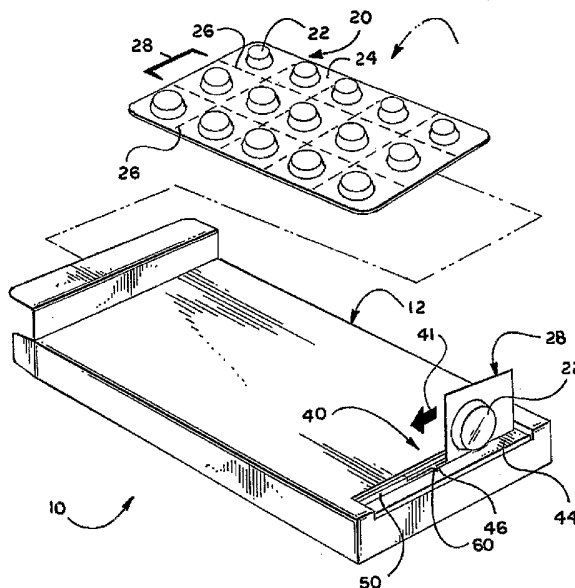

(57) Abstract: A system for storing and opening encased articles, such as those wrapped in a protective seal, provides a combined container and seal cutting apparatus. The container (12) is configured to store at least one removable article encased within a protective seal (28). The seal cutting apparatus (40) includes a receiving channel (50) and a cutting member (60) which extends into the receiving channel (50). The receiving channel (50) is configured to receive at least a portion of the seal (28) while the cutting member (60) is configured to cooperatively cut the seal portion as it is inserted into and translated along the channel (50). The cutting apparatus may be permanently or temporarily attached to the container.

WO 2004/113200 A1



-
- *before the expiration of the time limit for amending the claims and to be republished in the event of receipt of amendments*
- For two-letter codes and other abbreviations, refer to the "Guidance Notes on Codes and Abbreviations" appearing at the beginning of each regular issue of the PCT Gazette.*

5

SYSTEM FOR STORING AND UNPACKING ENCASED ARTICLES

CROSS-REFERENCE TO RELATED APPLICATIONS

This application claims the benefit of U.S. Provisional Application Serial No. 60/477,485
10 filed June 9, 2003.

BACKGROUND OF THE INVENTION

The invention relates to the packaging of encased articles such as those wrapped in a protective seal, and more specifically to an apparatus for storing and opening a unit blister-pack type package.

15 A blister-pack is a type of package wherein an item or article to be protected is sealed between a substantially planar substrate and a concave compartment structure resembling a "blister." The blister is typically made of a plastic type material. The substrate may be paper, foil, or plastic, or a laminate of one or more of these materials. The encased item or article is typically removed by pushing the article or item from the blister side of the pack through the planar
20 substrate. In the case of a child-resistant package, both the substrate and blister are made difficult to penetrate.

The blister-pack is useful for packaging individual, or unit, doses of pharmaceutical products. And, when used for this purpose, the blister-pack is particularly suitable for the packaging and distribution of multiple unit doses in a single package. A well known typical
25 multiple blister pack **20** arranged as an array of individual, or unit, dose blister packs is illustrated in Fig. 1. In the pack illustrated, each blister **22** contains a single (or individual, or unit) dose of a medication or similar item. Each unit dose is segregated by lines of demarcation **26**. The intersecting lines of demarcation **26** define individual unit dose blister-packs **28**. The line

5 of demarcation 26 may be a frangible line such as a perforated line that facilitates separation of a unit 28 from the multiple pack 20.

A problem with a blister-pack is that often it may be difficult to push the item or article, such as pill, through the substrate. This problem exists because often the substrate is made particularly durable to maintain the freshness and efficacy of the encased article. Sometimes the
10 substrate is made to inhibit removal of the encased article or item, as in the use of a child-resistant package. Thus, a need exists for a means for facilitating removal of an encased item or article from a blister-pack or similar protective seal.

It is known to provide a separate package opener that employs a protruding blade to puncture a substrate. However, such blades are typically exposed and create a hazard for users.
15 In addition, such blades are designed to substantially protrude into the package. This configuration creates the possibility of the blade puncturing or otherwise coming into contact with the enclosed item or article. This is especially undesirable in the case of items/articles such as capsules, gel caps or tablets that may be damaged if punctured. Further, it is generally undesirable for a non-sterile foreign object to come into contact with a consumable product.

20 Although prior attempts to solve the problem of removing an encased article from its protective seal are known, there remains the need for a convenient means to store encased articles together with a means for safely and efficiently cutting the unique protective seal that encases the article.

25 BRIEF SUMMARY OF THE INVENTION

The present invention provides a system for storing and opening encased articles. By way of example and not limitation, an encased article includes an item that is sealed by any

5 flexible or semi-flexible protective covering, shrink-wrapped, or blister-wrapped. For the purpose of efficiently teaching the present invention, and not as a limitation, the example of a blister-pack will be illustrated and described.

According to one embodiment of the invention, a channel for receiving a flanged edge of a unit dose blister-pack has a cutting edge disposed with respect to the channel so as to engage
10 the flanged edge that is translated along the channel.

In accordance with another embodiment of the invention, a channel for receiving a flanged edge of a unit dose blister-pack is defined between a blister abutment structure and a backstop structure. A cutting edge is disposed with respect to the channel so as to engage the flanged edge translated along the channel. The abutment structure is adapted to abut the blister
15 when the flanged edge is translated along the channel such that the cutting edge does not substantially protrude into the compartment, or cavity, defined by the blister. In accordance with another aspect of this embodiment the cutting edge projects from the backstop. In accordance with yet another aspect of this embodiment, a first height of the abutment structure is offset from a second height of the backstop structure.

20 Another embodiment of the invention teaches a container for receiving an array of encased articles and an apparatus for opening the seal that encases each of said articles. In accordance with another aspect of this embodiment, the apparatus for opening the seal is disposed within an opening of the container. In another aspect of this embodiment, the container has an opening at one end for receiving the array and the apparatus for opening the seal is
25 disposed at an opening at an opposing end, or an adjacent end, or the same end.

Other advantages and objects of the present invention will be apparent from the following description, the accompanying drawings, and the appended claims.

5

BRIEF DESCRIPTION OF THE DRAWINGS

Fig. 1 is an isometric view of the present invention.

Fig. 2 is an exploded view of the cutting apparatus of Fig. 1.

Fig. 3 is an exploded isometric view of the embodiment of Fig. 1.

Fig. 4 is the underside view of Fig. 3.

10

DETAILED DESCRIPTION OF THE INVENTION

Throughout the various figures, the same reference numerals are used to denote the same or like features of the invention.

Referring first to Fig. 1, therein is illustrated an apparatus **40** for opening the seal of an encased article, such as the seal which is a unit blister-pack package **28**. Also shown in Fig. 1, but which will be discussed in greater detail later, is a container **12** which together with the apparatus **40** form a system **10** in accordance with an embodiment of the invention. Further illustrated in Fig. 1 is an array **20** of unit dose blister-pack **28** packages.

Referring now simultaneously to Figs. 1 and 2, the apparatus **40** has a channel **50** with a cutting member **60** having a cutting edge **62** disposed with respect to the channel **50** such that a flanged edge of a unit dose blister-pack **28** is engaged when the flanged edge is translated along the channel **50**. One of the flanged edges of the blister-pack **28** is shown disposed within the channel **50** positioned for movement in the direction shown by the direction arrow **41**.

The channel **50** is defined by a blister abutment structure **44** and a back stop **48**. In Fig. 1, the blister **22** of the unit dose blister-pack **28** is shown abutting the abutment structure **44**. The underside of the unit dose blister-pack **28** is shown in contact with the backstop **48** in Fig. 1. In

5 this illustrated embodiment a first height of the abutment structure **44** is offset from a second height of the backstop, thereby forming a stepped or recessed structure for engaging a blister.

Referring again to Figs. 1 and 2 simultaneously, the cutting member **60** with its cutting edge **62** is shown positioned within and projecting into the channel **50** from the backstop **48**.

Referring now particularly to Fig. 2, therein can be seen the manner in which the cutting
10 member **60** can be seated within a seating compartment **64** in the backstop and held in place by a securing member **66**. It will be understood that the cutting member **60** may be permanently or temporarily integrated into the apparatus **40** by way of any number of methods known by those skilled in the art.

Referring now to Figs. 3 and 4 simultaneously, the apparatus **40** is shown separated from
15 the container **12**. To form the package **10** of Fig. 1, the apparatus **40** is inserted into the container **12** in the direction illustrated by the arrows **18**. In the embodiment illustrated, the apparatus **40** is held in place at the opening **16** of the container by cooperation between detents **42** of the apparatus and slots **14** of the container. As will be understood by those skilled in the art, the apparatus **40** may be attached to the container **12** with mechanical or chemical means including
20 tabs, couples, tapes, adhesives or formed integrally therewith. Alternatively the apparatus **40** may be removably attached to the container **12**.

Referring again to Fig. 1, in operation the end-user separates a unit dose blister pack **28**
from the array package **20** by tearing along lines of demarcation **26**. A flanged edge of an individual, or unit, dose blister-pack **28** is then inserted in the channel **50** and translated in the
25 direction of arrow **41** to cut along the unit dose blister pack **28**. The abutment of the blister **22** with the abutment member **44** helps position the pack **28** so that the cutting edge **62** of the cutting member **60** engages the pack **28** below the blister **22** compartment or so close to the

5 perimeter of the blister 22 compartment that the cutting edge 62 does not substantially project into the cavity, or compartment, formed by the blister 22. A relief nick 46 is positioned adjacent the cutting edge 62 and the cutting member 60. The relief nick 46 allows the flanged edge of the pack 28 to deform slightly and depart from the path of the channel sufficiently to prevent bunching at the cutting edge and thereby facilitate initiation of and cutting of the pack 28.

10 This specification conveys the best mode for carrying out the invention known to the inventor at the time of filing the patent application. Modifications and alternative embodiments may be made in the foregoing without departing from the scope and spirit of the present invention as defined in the appended claims.

5 We claim:

1. A system for storing and opening encased articles, comprising:

a container (12) configured to store at least one removable article encased within a protective seal (28);

a seal cutting apparatus (40), in combination with said container (12), comprising:

10 a receiving channel (50) defined by a first edge (44) spaced apart from a substantially parallel second edge (48);

a cutting member (60) including a cutting edge (62), said cutting member (60) positioned so said cutting edge (62) extends between said first edge (44) and said second edge (48);

15 wherein said receiving channel (50) is configured to slideably receive at least a portion of said seal (28) and said cutting edge (62) is configured to cooperatively cut said seal portion as it is inserted into and translated along said channel (50); and,

wherein said cut seal portion facilitates access to said article.

2. The system of claim 1, wherein said cutting apparatus (40) is fastened to said
20 container (12).

3. The system of claim 2, wherein said first edge (44) defines a slideable abutment structure and said second edge (48) defines a backstop.

4. The system of claim 3, wherein said backstop (48) includes a seating compartment (64) which receives and seats said cutting member (60).

5 5. The system of claim 4, wherein said cutting member (60) is stabilized and bound
by a securing member (66).

6. The system of claim 5, wherein said cutting edge (62) projects away from said
backstop (48) and extends into a relief nick (46) integral to said slideable abutment structure.

7. A method of providing and opening encased articles, comprising:
10 providing a combination container and seal cutting apparatus;
 inserting a plurality of articles into said container, wherein said articles are
encased within individual protective seals;
 distributing said container with articles and seal cutting apparatus to an end-user;
 removing a first article from said container;
15 inserting at least a portion of said first article's protective seal into said seal
cutting apparatus;
 operating said seal cutting apparatus to cut said portion of seal; and,
 retrieving said article from said protective seal.

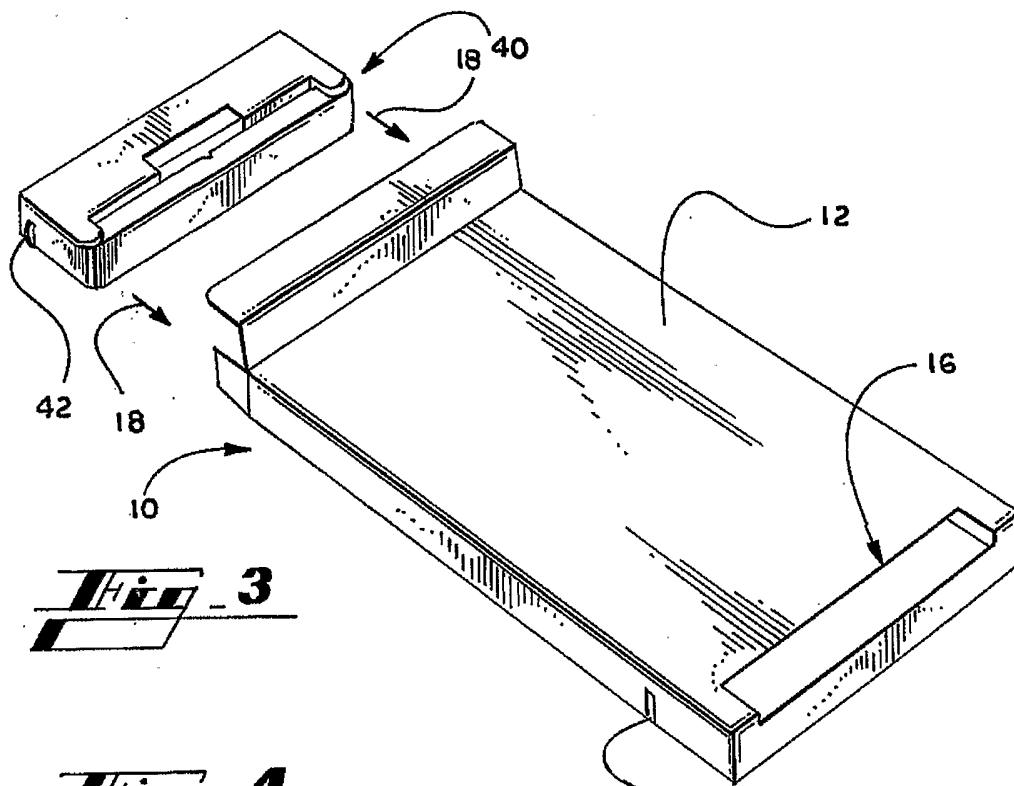

Fig. 3

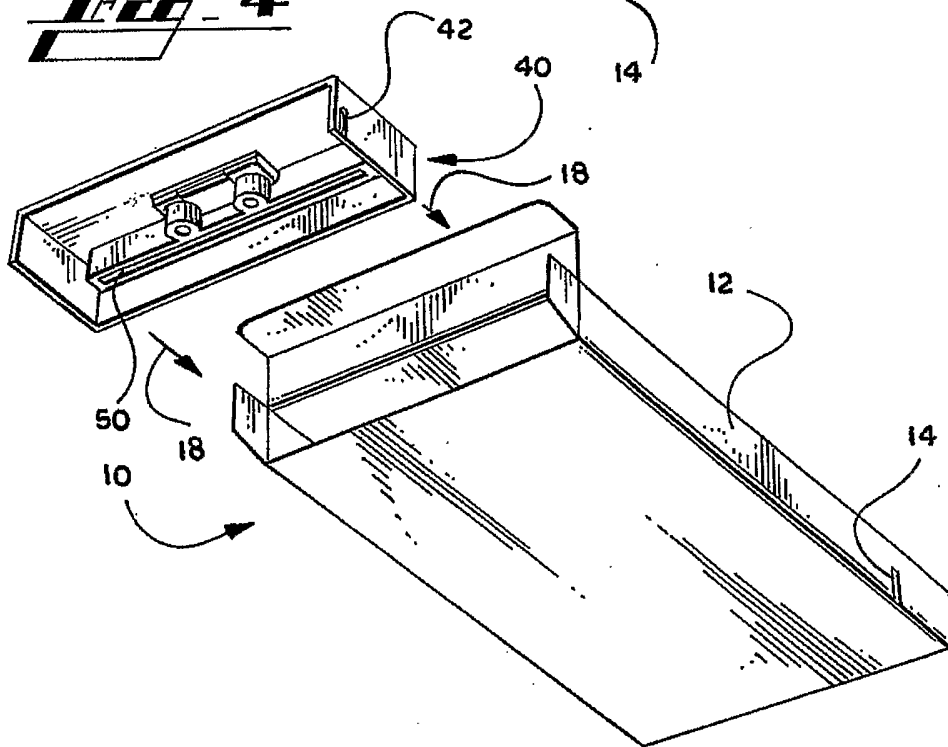

Fig. 4

INTERNATIONAL SEARCH REPORT

PCT/US2004/018257

A. CLASSIFICATION OF SUBJECT MATTER
 IPC 7 B65D83/04 A61J1/03

According to International Patent Classification (IPC) or to both national classification and IPC

B. FIELDS SEARCHED

Minimum documentation searched (classification system followed by classification symbols)
 IPC 7 B65D A61J B65B

Documentation searched other than minimum documentation to the extent that such documents are included in the fields searched

Electronic data base consulted during the international search (name of data base and, where practical, search terms used)
 EPO-Internal

C. DOCUMENTS CONSIDERED TO BE RELEVANT

Category °	Citation of document, with indication, where appropriate, of the relevant passages	Relevant to claim No.
X	US 5 332 096 A (BATTAGLIA ANNA D) 26 July 1994 (1994-07-26) column 3, line 22 - line 51; figure 5 -----	1,7

Further documents are listed in the continuation of box C.

Patent family members are listed in annex.

- ° Special categories of cited documents :
- *A* document defining the general state of the art which is not considered to be of particular relevance
 - *E* earlier document but published on or after the international filing date
 - *L* document which may throw doubts on priority claim(s) or which is cited to establish the publication date of another citation or other special reason (as specified)
 - *O* document referring to an oral disclosure, use, exhibition or other means
 - *P* document published prior to the international filing date but later than the priority date claimed
 - *T* later document published after the international filing date or priority date and not in conflict with the application but cited to understand the principle or theory underlying the invention
 - *X* document of particular relevance; the claimed invention cannot be considered novel or cannot be considered to involve an inventive step when the document is taken alone
 - *Y* document of particular relevance; the claimed invention cannot be considered to involve an inventive step when the document is combined with one or more other such documents, such combination being obvious to a person skilled in the art.
 - * & * document member of the same patent family

Date of the actual completion of the international search 4 November 2004	Date of mailing of the international search report 15/11/2004
--	--

Name and mailing address of the ISA European Patent Office, P.B. 5818 Patentlaan 2 NL - 2280 HV Rijswijk Tel. (+31-70) 340-2040, Tx. 31 651 epo nl, Fax: (+31-70) 340-3016	Authorized officer Bridault, A
--	---------------------------------------

INTERNATIONAL SEARCH REPORT

PCT/US2004/018257

Patent document cited in search report	Publication date	Patent family member(s)	Publication date
US 5332096	A	26-07-1994	NONE