



US 20110285609A1

(19) **United States**

(12) **Patent Application Publication**
Engel

(10) **Pub. No.: US 2011/0285609 A1**

(43) **Pub. Date: Nov. 24, 2011**

(54) **MULTI-VIEW DISPLAY**

(30) **Foreign Application Priority Data**

(75) **Inventor: Gabriel Damon Engel, Hamilton (NZ)**

Sep. 20, 2002 (NZ) 521505

Publication Classification

(73) **Assignee: PURE DEPTH LIMITED, Auckland (NZ)**

(51) **Int. Cl. G09G 5/00 (2006.01)**

(52) **U.S. Cl. 345/4**

(21) **Appl. No.: 12/948,638**

(57) **ABSTRACT**

(22) **Filed: Nov. 17, 2010**

A display device includes a first display screen operable to display a first image. A second display screen is operable to display a second image, wherein the first and second display screens overlap, and wherein the second display screen is further operable to display the second image for viewing from a first viewing angle and contemporaneously for reducing visibility of the second image from a second viewing angle.

Related U.S. Application Data

(63) Continuation of application No. 10/528,334, filed on Mar. 13, 2006, filed as application No. PCT/NZ03/00215 on Sep. 19, 2003.

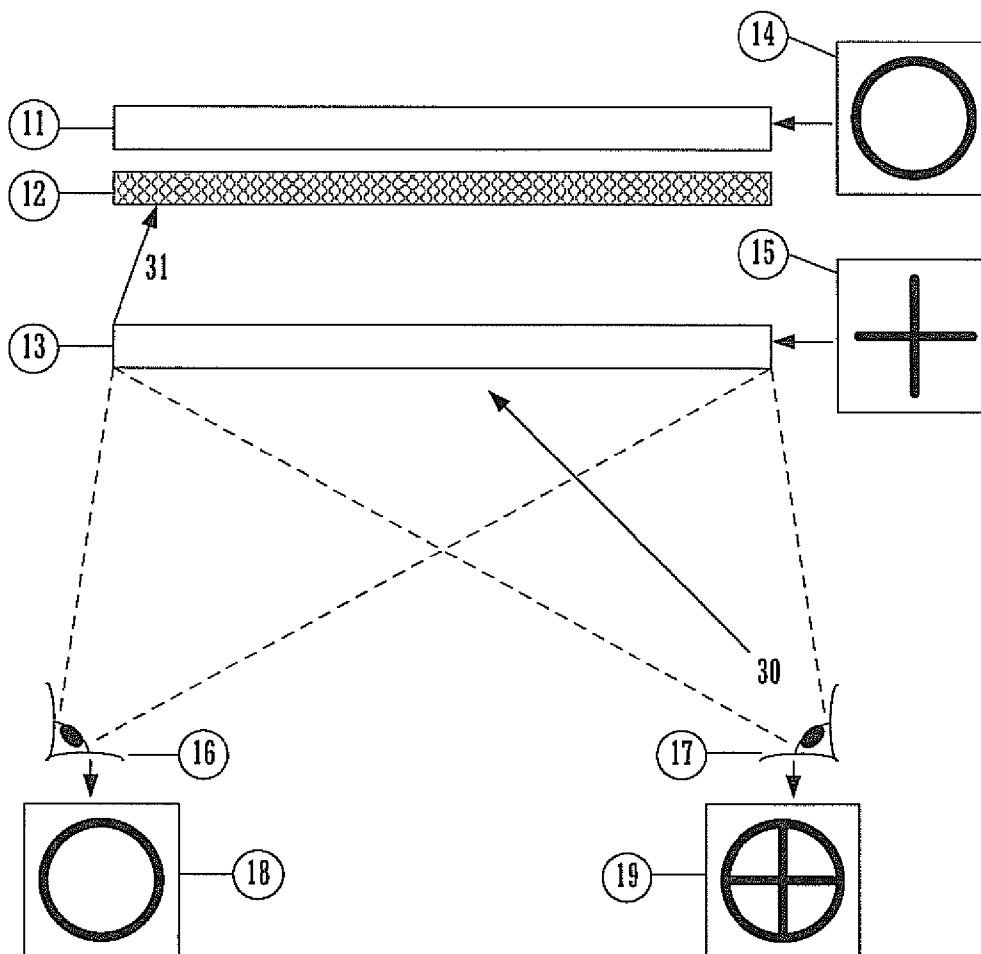

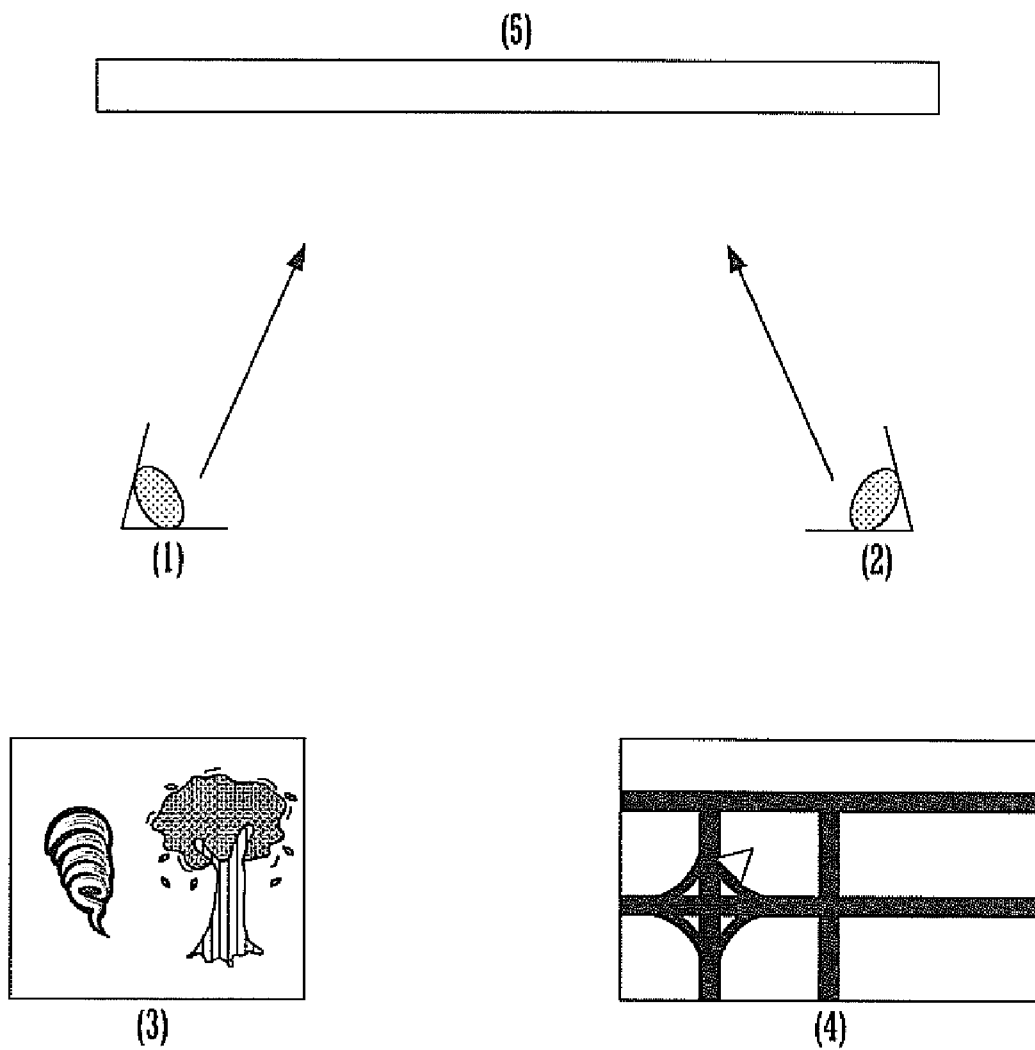

FIGURE 1

(10)



(5)



(9)



(7)

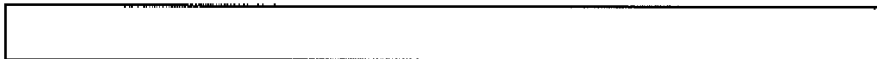

FIGURE 2

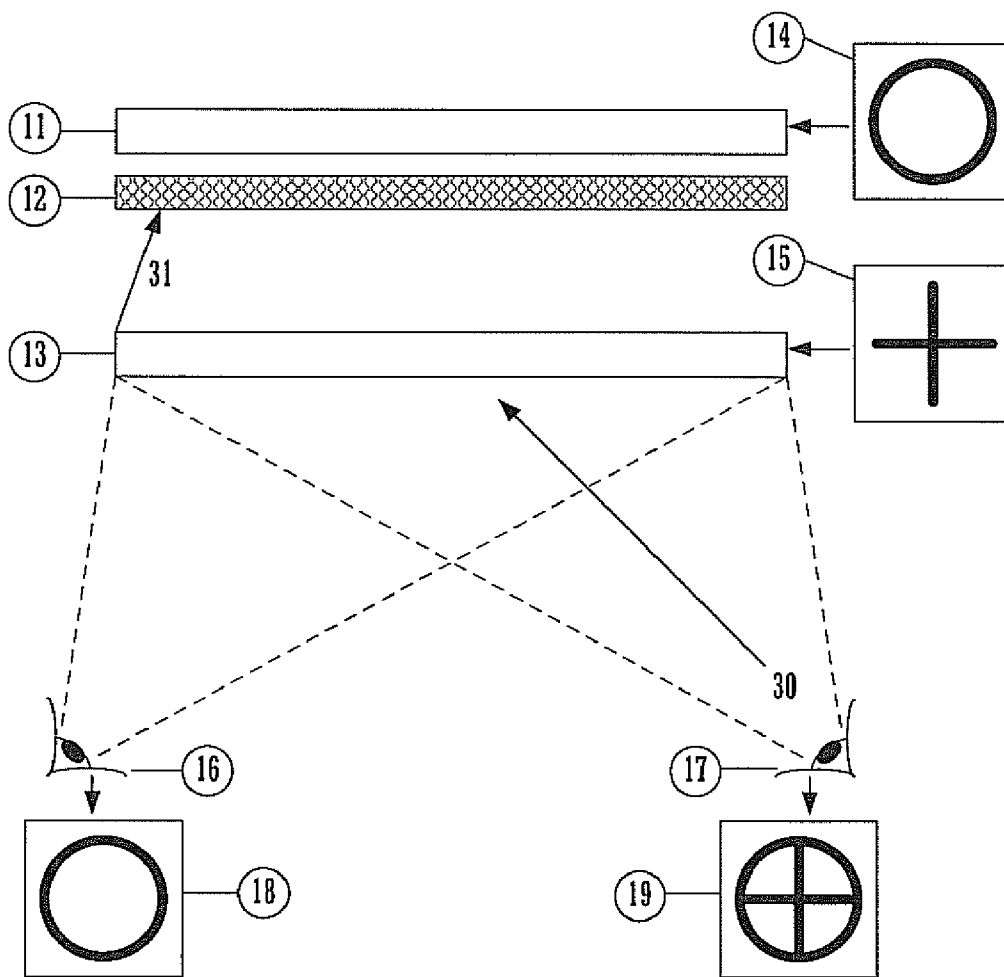

FIGURE 3

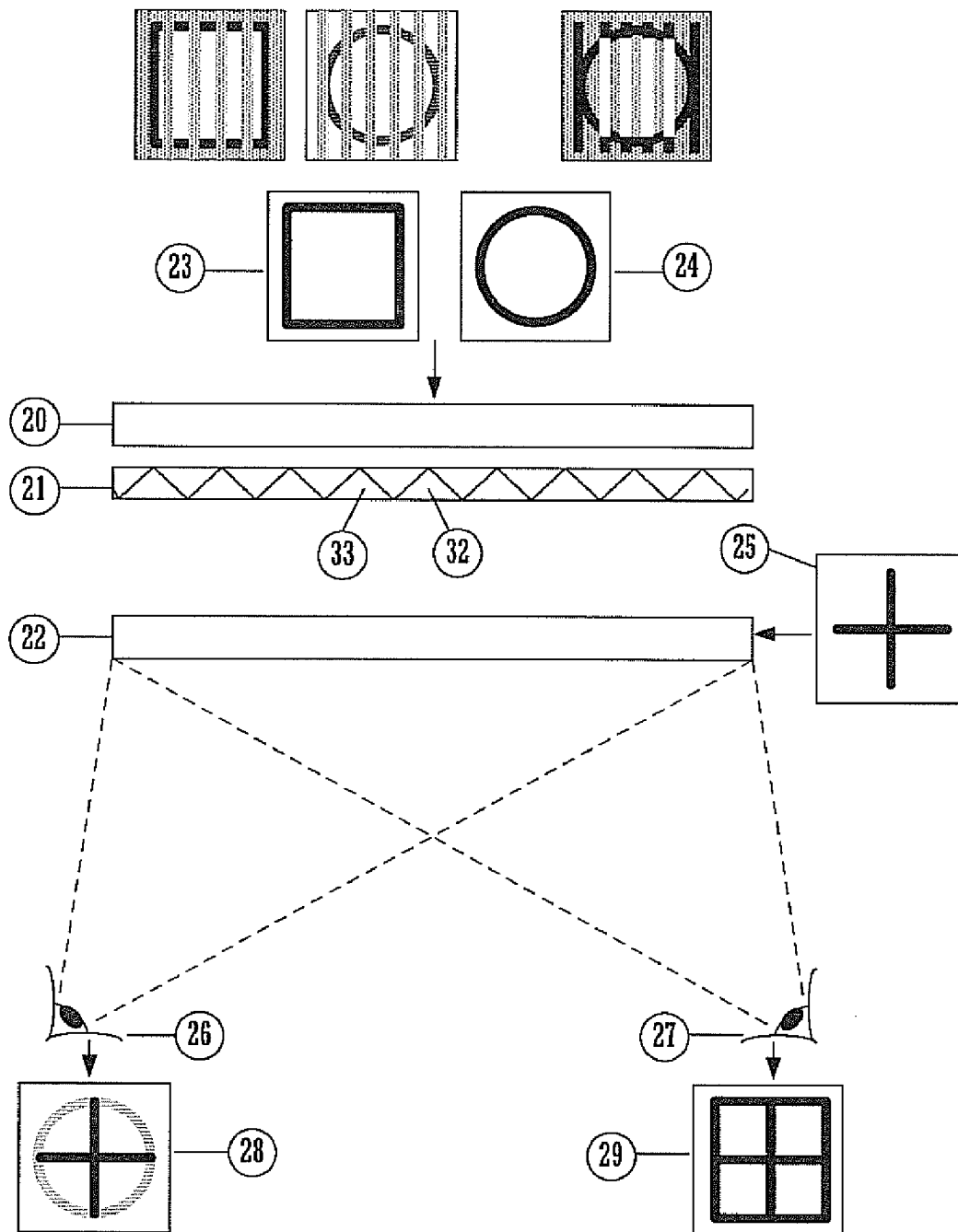

FIGURE 4

MULTI-VIEW DISPLAY

RELATED APPLICATIONS

[0001] The present application is a continuation of U.S. patent application Ser. No. 10/528,334, filed Mar. 13, 2006, naming Gabriel Engel as the inventor, assigned to the assignee of the present invention, and having attorney docket number PURE-P013, which is a National Stage Application filed under 35 U.S.C. §371 of International Patent Application Number PCT/NZ03/000215, filed Sep. 19, 2003, which claims the benefit of New Zealand Patent Number 521505, filed Sep. 20, 2002. These applications are incorporated herein by reference in their entirety and for all purposes.

BACKGROUND OF THE INVENTION

[0002] In-car navigation systems and in-car entertainment systems are available as an accessory in new cars, or are available separately for retrofit, commonly called after market sales. The displays for the systems are placed in or on top of the car dash board. Since the displays are typically of the wide-viewing angle colour liquid crystal type, both the front passenger and the driver may see the display. The display may be supplied with information so that it forms part of the car's navigation system or part of the entertainment system at any one time. If an in-car entertainment system is fitted in view of the driver, the video component such as television and DVD must be disabled whilst the car is in motion, so not to distract the driver who is responsible for the safety of the vehicle. This is federally mandated safety requirement in many countries and is somewhat of a disadvantage as it is desirable for the front passenger, and only the front passenger, to view in-car entertainment. In practice many owners disable this safety feature resulting in potentially fatal distraction for the driver. However, it is also useful for the driver view the in-car navigation system whilst the vehicle is moving. With present systems this would interrupt the passenger's entertainment. A potential solution would be to supply separate displays to the passenger and driver, however this increases expense and takes up almost double the area restricting design flexibility of the dash board control canter and reducing the space available for peripheral devices and storage space.

[0003] Long airplane flights are particularly boring for passengers. Airlines have attempted to alleviate this boredom by including projector systems on the airplanes to supply information about the journey and entertainment. However with a single projector system the entertainment is the same for each passenger, and there is no accounting for individual taste or interest. This problem has been alleviated in some airplanes with separate displays for each passenger, however a display for each passenger generally increases expense requires individual displays to be quite small, and can add significant weight to the plane increasing costs for airlines.

[0004] It is the object of the present invention specifically to allow a passenger to view full entertainment features such as television and movies on the same display device that a driver can view navigation information without conflict between images and thus to reduce components, reduce complexity, reduce driver distraction, and increase passenger enjoyment. To do this one requires to control the viewing angle of a display. There exist various methods to do this.

[0005] Certain environments such as kiosks or ATM's require privacy. Privacy film or filters are common in the marketplace which reduce the viewing angle in which the

viewer can only see the displayed images within a certain angle—typically directly in front of the display. A simple solution for a privacy screen is to laminate a view control film onto a screen. 3M are well known for producing these products which control the position from where the display can be viewed. The two most common types of privacy film are light control film and blur film. Light control film acts like Venetian blinds. If the observer were to stand at 60° to the front of these blinds the view would be blocked by the sides of the “louvers”. However when the observer stands directly in front of the “blinds” the display is viewable. Holographic diffusion film works by dispersing the incident light at particular angles and transmitting it at all other angles. The display appearance changes from translucent to transparent depending on the viewing angle.

[0006] A prismatic film or ‘image directing film’ can be used to direct the image displayed on a display device. The film rakes the image created by a flat panel display and redirects it to the optimum viewing angle, generally through refraction.

[0007] Parallax barrier methods and lenticular lenses can also be used to direct light.

[0008] Viewing angle can also be controlled by the liquid crystal itself. Viewing angle, which is in the same direction as the maximum contrast, can be controlled by the liquid crystal cell structure itself. The contrast ratio is defined as the ratio of maximum luminance to the minimum luminance. Since the retardation experienced by the ray traversing at the midlayer tilt angle is the lowest in this direction in a normally black panel, the luminance in this direction is lower resulting in a lower contrast ratio. Both the azimuth and tilt of this angle can be controlled by changing the azimuth and tilt angle on the alignment layers respectively. See Liquid Crystal Displays by Ernst Lueder, Wiley/SID series in display technology incorporated herein by way of reference.

[0009] At present there exist methods to produce displays where several imaging planes are stacked with set distances between them. These imaging planes may also be stacked as closely as possible. In a preferred embodiment these displays consist of a high-brightened backlight, and multiple image planes including but limited to a background image panel and a front image plane, which are parallel and physically separate and generally are laminated to form a stack. There are generally color filter stripes, and a matrix on each display which defined the borders of the pixels and a method of eliminated Moiré interference. The following discussion applies to all image planes that are addressed by passive or active matrices or have filters arranged in any periodic pattern but not limited to those described above.

[0010] The viewing angle of liquid crystal displays can be controlled by the orientation of the liquid crystal molecules with respect to the glass substrates that form the display. Optimum Viewing angle here means the direction a viewers looks in where the display contrast, the ratio between the luminance of the light and dark states of the display, is at a maximum. Orientation here is defined as a three-tuple where each element gives the magnitude of the angle between the x, y and z axes respectively where the x, y and z axes are aligned parallel with the horizontal, vertical and normal directions of the display respectively.

[0011] It has previously been considered undesirable for displays to have a narrow viewing angle because this prohibits multiple users from viewing the same image. However in the case of a car navigation and entertainment system it would

be desirable for the driver to be able to see navigation information, and only navigation information and the passenger to see entertainment, and only entertainment. For safety, space and cost constraints it would be useful for both passengers to have different images views from the same display.

[0012] All references, including any patents or patent applications cited in this specification are hereby incorporated by reference. No admission is made that any reference constitutes prior art. The discussion of the references states what their authors assert, and the applicants reserve the right to challenge the accuracy and pertinence of the cited documents. It will be clearly understood that, although a number of prior art publications are referred to herein, this reference does not constitute an admission that any of these documents form part of the common general knowledge in the art, in New Zealand or in any other country.

[0013] It is acknowledged that the term “comprise” may, under varying jurisdictions, be attributed with either an exclusive or an inclusive meaning. For the purpose of this specification, and unless otherwise noted, the term “comprise” shall have an inclusive meaning, e.g., that it will be taken to mean an inclusion of not only the listed components it directly references, but also other non-specified components or elements. This rationale will also be used when the term “comprised” or “comprising” is used in relation to one or more steps in a method or process.

[0014] It is an object of the present invention to address the foregoing problems or at least to provide the public with a useful choice.

[0015] Further aspects and advantages of the present invention will become apparent from the ensuing description which is given by way of example only.

SUMMARY OF THE INVENTION

[0016] Accordingly in a first aspect of the present invention may broadly be said to consist in a multi view display for viewing different images at specified viewing angles, the multi view display comprising: a display layer for the display of images; and an un-braiding viewing angle manipulation means which manipulates the viewing angle of the images displayed on the display layer, such that when at least two images are be interlaced and displayed on the display layer, each constituent image of the interlaced image is presented at the viewing angle or viewing angles as determined by the un-braiding viewing angle manipulation means.

[0017] Preferably two images will be presented to the viewer or viewers at different viewing angles using the present invention. Those images are interlaced and displayed on the display layer. The images are interlaced in such a way that the un-braiding viewing angle manipulation means separates out or ‘unbraids’ the constituent images in the interlaced image and presents the constituent images at different viewing angles. Using this technique, the observer will see one of the constituent images from one viewing angle and other constituent images from other viewing angles. While this specification refers to the presentation of two images this should not be seen as limiting. Those skilled in the art will appreciate that greater numbers of images can be interlaced and subsequently displayed to various viewing angles.

[0018] The term viewing angle manipulation means should be interpreted to mean any device used to direct light in certain directions or prevent light from proceeding in certain directions, this includes wide angle diffusers, privacy film, image or optical directing film.

[0019] The term un-braiding viewing angle manipulation means is preferably an adapted viewing angle manipulation means such as a privacy film, image directing film or compensation film. Typically this will involve interlacing at least two viewing angle manipulation means which direct light at different angles. For example by interlacing two image directing films of which have different refraction angles to each other, the film will be capable (when applied to an interlaced image, which is interlaced consistently with the interlaced image directing films) of directing images to two different viewing angles.

[0020] The term viewing angle as used here in should be interpreted as relating to the angle at which images displayed on a display device or pixel are viewable some a wide viewing angles may close to 100% or 180 degrees. Typically narrower viewing angles will be used to narrow the angles from which images can be viewed.

[0021] Throughout this specification reference is made to privacy film or image directing film or other viewing angle manipulation means. However this should not be seen as limiting. Those skilled in the art will appreciate that any means of directing images to viewing angles can be used with the present invention.

[0022] In the present invention, the unbraiding viewing angle manipulation means has the ability to present images displayed on the display device to different viewing angles. This can be achieved by interlacing two different image directing films each of which is designed to present images to a viewing angles angle which is different to the other interlaced privacy film.

[0023] The interlacing of images and their display needs to be consistent with the un-braiding viewing angle manipulation means used. In the case of two images which are interlaced, two optical viewing films with different viewing angles to each other will be used with corresponding interlacing between the unbraiding viewing angle manipulation means and the interlaced image displayed.

[0024] Preferably each of the at least two interlaced images are presented to a different viewing angles than the other image(s).

[0025] Accordingly in a further aspect of the present invention may broadly be said to consist in a multi view display for viewing different images at specified viewing angles, the multi view display including: an adapted display layer for the display of images, wherein the adapted display layer includes at least two different specified viewing angle pixels which are interlaced, such that when at least two images are interlaced and displayed on the adapted display layer, each constituent image of the interlaced image is presented to the viewing angle or viewing angles as determined by the viewing angle of the interlaced specified viewing angle pixels.

[0026] The term “specified viewing angle pixel” as used herein should be interpreted to include a pixel which is produced to have a defined viewing angle; that is the contrast ratio of the pixel is optimal for a certain scope of viewing angle. The control of viewing angle of a pixel is found commonly in the market. For example displays which are intended to be located higher than the intended viewer have a viewing angle pointing down.

[0027] Different specified viewing angle pixels which have different viewing angles are interlaced within the adapted display layer. Preferably two images will be presented to the viewer or viewers. Those images are interlaced and displayed on the adapted display layer. The images are interlaced in

such a way that the specified viewing angle pixels separate out or “unbraid” the constituent images from the interlaced image (e.g., displayed on the adapted display layer) and presents the constituent images at different viewing angles. Using this technique, the observer will see one of the constituent images from one viewing angle and the other constituent image from another viewing angle.

[0028] Accordingly in a further aspect of the present invention may broadly be said to consist in a multi view display for viewing different images at specified viewing angles, the multi view display including: an adapted display layer for the display of images, wherein the adapted display layer includes at least two different specified viewing angle pixels which are interlaced; and an un-braiding viewing angle manipulation means, such that when at least two images are interlaced and displayed on the adapted display layer, each constituent image of the interlaced image is presented to the viewing angle or viewing angles as determined by the viewing angle of the interlaced specified viewing angle pixels in combination with the unbraiding viewing angle manipulation means.

[0029] In this embodiment the combination of a manipulation means preferably an interlaced privacy film or light directing means is used in combination with interlaced specified viewing angle pixels. The combination of these mechanisms allows greater control of the viewing angle to which images are presented.

[0030] Accordingly in a further aspect of the present invention may be broadly said to consist in a multi-layer multi view display for displaying different images at specified viewing angles, the multi view display including: at least two display layers for the display of images, the display layers being substantially planar and at least in part overlapping, wherein the display layer(s) overlapping another display layer are selectively transparent; and an un-braiding viewing angle manipulation means acting upon at least one of the display layers and thereby manipulating the viewing angle of images displayed on the display layer(s) behind it, such that when at least two images are interlaced and a display layer which the un-braiding viewing angle manipulation means is acting upon, each constituent image of the interlaced image displayed on the layer(s) (which the un-braiding viewing angle manipulation means is acting upon) is presented at the viewing angle or viewing angles as determined by the un-braiding viewing angle manipulation means.

[0031] In one preferred embodiment of the present invention the display device is made up of a two layered multi-layer display, being backlit, with each layer being selectively transparent. In between those layers an interlaced lens with a triangle strip pattern with particular viewing angles acting as a viewing angle manipulation means acts on the rear most layer. The interlaced lens allows the constituent images of an interlaced image displayed on the rear screen to be seen from the viewing angles specified by the interlaced lens.

[0032] A conventional non-layered, non-compensated color liquid crystal display, contrast ratio decreases until to a crossover point at which the image inverts when viewed from outside the optimal viewing angle. This results in images being “washed out” and beyond the cut-off point these colors invert completely with black changing to white.

[0033] In the multi-layered setup used in a multi view display as described herein, the display may be transparent. In one embodiment, if a driver is looking at the rear image layer with a viewing direction of about 60 degrees in the plane perpendicular to the floor and parallel with the horizontal and with the front image layer with an optimal viewing direction of -60 degrees in the plane, then the driver may be able to see the image on the rear image layer and not on the front image

layer. Conversely, the passenger, sitting to the other side of the display, may only be able to see information from the front image layer. Hence, the passenger may be able to view entertainment and the driver can view navigation. Thus, limited viewing angle, which was previously considered a disadvantage in the industry, combined with multiple layered displays can be used to multiplex images to multiple viewers as an unexpected advantage.

[0034] Accordingly in a further aspect of the present invention may be broadly said to consist in a multi-layer multi view display for displaying different images at specified viewing angles, the multi view display including: at least two display layers for the display of images, the display layers being substantially planar and at least in part overlapping, wherein the display layer(s) overlapping another display layer are selectively transparent, where in at least one of the display layers is an adapted display layer comprising pixels which are specified viewing angle pixels, such that images displayed on the at least one adapted display layer will be presented to the viewing angle of the specified viewing angle pixels.

[0035] Preferably the images displayed on the at least one adapted display layer have a different viewing angle to the images displayed on the other (non-adapted) display layer(s).

[0036] In a preferred embodiment of the present invention the display device is made up of a two layered multi-layer display, being backlit, with each layer being selectively transparent. Both display layers are adapted display layers, having specified viewing angle pixels where the viewing angle of each of the two layers is opposite such that a viewer from the left will see the image displayed one layer and a viewer from the right will see the image displayed on the other layer.

[0037] Accordingly in a further aspect of the present invention may be broadly said to consist in a multi-layer multi view display for displaying different images at specified viewing angles, the multi view display including: at least two display layers for the display of images, the display layers being substantially planar and at least in part overlapping, wherein the display layer(s) that are overlapping another display layer are selectively transparent, a viewing angle manipulation means with a wide viewing angle acting upon at least one display and being located behind at least one display, such that images displayed upon display layers that the viewing angle manipulation means is acting on are presented to the viewing angle determined by the viewing angle manipulation means.

[0038] In a preferred embodiment two display layers are overlapped and transparent and are backlit. The front layer has a narrow viewing angle to the left (from the viewer's perspective) behind this is a further narrow viewing angle display but acting upon it is a wide angle diffusion refractor. Hence the images displayed on the rear layer are viewable from a wide viewing angle and the images displayed on the front layer are viewed only from the left (and are viewed as being layered on top of images displayed on the back layer). The diffusing refractor will assist in overcoming the Moiré interference arising as a result of layering two like substrates.

[0039] Accordingly in a further aspect of the present invention may be broadly said to consist in a multi-layer multi view display for displaying different images at specified viewing angles, the multi view display including: at least two display layers for the display of images, the display layers being substantially planar and at least in part overlapping, wherein the display layer(s) that are overlapping another display layer are selectively transparent, wherein at least one of the display layers is an adapted display layer comprising of at least two different specified viewing angle pixels which are interlaced, and all layers to the rear of that adapted display layer (if any)

are adapted display layers and also comprising at least one an un-braiding viewing angle manipulation means acting upon the adapted the display layer(s) behind it, such that when at least two images are interlaced and displayed on the adapted display layer, each constituent image of the interlaced image is presented to the viewing angle as determined by the viewing angle of the interlaced specified viewing angle pixels in combination with the unbraiding viewing angle manipulation means.

[0040] Preferably the multi view display is adapted to receive images from a CPU or other image transferring device such as a DVD or video playback.

[0041] Accordingly a further aspect of the present invention comprises a method of operating a multi view display the multi view display having at least two viewing angles characterized by the steps of displaying each images intended for each viewing to the display layer which presents that image to the intended viewing angle.

[0042] Accordingly a further aspect of the present invention comprises display software adapted to facilitate the display of images using multi view display the multi view display having at least two viewing angles the display software being adapted to execute the steps of transmitting each images intended for each viewing to the display layer which presents that image to the intended viewing angle:

[0043] Accordingly a further aspect of the present invention comprises a method of operating a multi view display the multi view display comprising at least two multi layered display layers characterized by the steps of: displaying interlaced images on display layers on which an un-braiding viewing angle manipulation means acts; and displaying non-interlaced images on any display layers (if any) on which no un-braiding viewing angle manipulation means acts.

[0044] Accordingly a further aspect of the present invention comprises display software adapted to facilitate the display of images using a multi view display the multi view display comprising at least two multi layered display layers, the display software being adapted to execute the steps of: transmitting interlaced images to display layer(s), the display layer(s) having an un-braiding viewing angle manipulation means acting upon it (them), the interlaced image being acted upon by the un-braiding viewing angle manipulation means to present the constituent images of the interlaced image to differing viewing angles; and transmitting (non-interlaced) image data to display layers (if any) on which no unbraiding viewing angle manipulation means acts the image data being used by the display components to display a images to the viewing angle inherent to the display layer.

[0045] The display layer used in the invention can be any kind of display device such as a Liquid Crystal Display (LCD), an Organic Light Emitting Diode Display (OLED) or any other type of display. A display screen may include interlaced pixels and/or be at least partially transparent.

[0046] Reference throughout this specification is made the present invention as applying to video display systems. However, it should be appreciated by those skilled in the art that other types of display and imaging systems may be used in conjunction with the invention, not necessarily being video screens such as but not limited to hand held or arcade video games, desktop computers, security monitors, process control system monitors.

BRIEF DESCRIPTION OF THE DRAWINGS

[0047] Further aspects of the present invention will become apparent from the following deposition which is given by way of example only and with reference to the accompanying drawings.

[0048] FIG. 1 shows a display device with a single layer in accordance with one embodiment of the present invention.

[0049] FIG. 2 shows a display device with multiple layers in accordance with one embodiment of the present invention.

[0050] FIG. 3 is a diagrammatic view of a multi-layer multi view embodiment of the present invention in which the front layer is viewable only by one observer and the rear layer is viewable by both observers in accordance with one embodiment of the present invention.

[0051] FIG. 4 is a diagrammatic view of a multi-layer multi view embodiment of the present invention in which the front display layer is viewable by both observers and two interlaced images displayed on the rear display layer are presented to different observers in accordance with one embodiment of the present invention.

DETAILED DESCRIPTION OF THE INVENTION

[0052] In a first preferred embodiment a single layer display is used to at least two different images or display contents each image/display-content being presented to a different viewing angle to the images/display-content.

[0053] FIG. 1 illustrates single layer multi view display which can be used as an in-car navigation/entertainment device. A viewer (1) looking at the display (5) in the direction shown sees a movie being played (3), whilst a second viewer (2) looking at the display in the direction shown sees the image of a navigation system (4). In this embodiment the display layer (5) is adapted such that it comprises interlaced pixels of two different viewing angles. The movie is displayed on pixels of one viewing angle and the navigation images are displayed on pixels of the other viewing angle.

[0054] In a further preferred embodiment a multi-layered multi view device is used to display at least two different images or display contents each image/display-content being presented to a different viewing angle to the images/display-content.

[0055] FIG. 2 illustrates a display device with multiple display screens which can be used as a combined in-car navigation and entertainment display. A first layer (7) with optimum viewing direction (6) is placed substantially col-linear and as close to a second layer (5) with an optimum viewing direction (8). In most cases there will be a diffusion layer (9) to abate Moiré interference. The displays can be back lit using either direct view lamps or a light pipe (10). A viewer viewing at an angle (6) will see image (3), and a viewer looking in direction (8) will see image (4).

[0056] In a further preferred embodiment a multi-layered multi view device is used to display layered images to one viewer and a single image to another viewer.

[0057] FIG. 3 illustrates a multi layered multi view device. An image (15) is displayed on the first layer (13) with an optimum viewing direction (30) and an image (14) is displayed on a second layer (11) through a viewing angle enhancer (12) which expands the viewing angle (31) of second layer (11) with an optimum viewing angle of (31), such that a viewer (17) inline with the viewing angle of the first layer (30) would see a combined image. (19) with the image (14) from the second layer (11) would appear at distance behind the image (15) from the first layer (13) and such that a second simultaneous viewer (16) outside the viewing angle (30) of the first layer would see an image (18) only represented by the second layer (11).

[0058] In a further preferred embodiment a multi-layered multi view device is used in combination with an interlaced optical film or lens.

[0059] FIG. 4 illustrates a diagrammatic view of the multi-layered privacy embodiment where image (25) is displayed

on the first layer (22) and multiple images (23, 24) are displayed on the back layer (20) such that the images are interlaced to match a lens stripe pattern (21) allowing a viewer (27) in position inline with pattern (32) matching the image (23) on the rear layer (20) to see a composite image (29) comprising the foreground image (25) in front of a background image (23) that is aligned with the viewer's position, while allowing a second simultaneous viewer (26) in position inline with a pattern (33) matching the image (24) on the rear layer (20) to see a composite image (28) comprising the foreground image (25) in front of a background image (24) that is aligned with the viewer's position.

[0060] Aspects of the present invention have been described by way of example only and it should be appreciated that modifications and additions may be made thereto without departing from the scope thereof.

What is claimed is:

- 1. A display device comprising: a first display screen operable to display a first image; and a second display screen operable to display a second image, wherein said first and second display screens overlap, and wherein said second display screen is further operable to display said second image for viewing from a first viewing angle and contemporaneously for reducing visibility of said second image from a second viewing angle.
- 2. The display device of claim 1, wherein said second display screen is further operable to display a third image, and wherein said second display screen is further operable to display said third image for viewing from said second viewing angle and further for reducing visibility of said third image from said first viewing angle.
- 3. The display device of claim 2, wherein said second and third images are interlaced.
- 4. The display device of claim 1 further comprising: an optical component operable to reduce visibility of said second image from said second viewing angle, and wherein said first optical component is further operable to reduce visibility of a third image from said first viewing angle.
- 5. The display device of claim 4, wherein said optical component is disposed between said first and second display screens.
- 6. The display device of claim 4, wherein said optical component is selected from a group consisting of a privacy film, an image directing film, an optical directing film, and a lens including a lens stripe pattern.
- 7. The display device of claim 1 further comprising: a component operable to enable viewing of said first image from said first and second viewing angles.
- 8. The display device of claim 7, wherein said component is selected from a group consisting of a diffuser and a refractor.
- 9. A display device comprising: a first display screen operable to display a first image; and a second display screen operable to display a second image, wherein said first and second display screens overlap; and an optical component disposed between said first and second display screens, wherein said optical component is

operable to enable viewing of said second image from a first viewing angle and contemporaneously operable to reduce visibility of said second image from a second viewing angle.

10. The display device of claim 9, wherein said optical component is selected from a group consisting of a privacy film, an image directing film, an optical directing film, and a lens including a lens stripe pattern.

11. The display device of claim 9, wherein said second display screen is further operable to display a third image, wherein said optical component is further operable to enable viewing of said third image from said second viewing angle, and wherein said optical component is further operable to reduce visibility of said third image from said first viewing angle.

12. The display device of claim 11, wherein said second and third images are interlaced.

13. A display device comprising:

a first display screen operable to display a first image; and a second display screen operable to display a second image for viewing from a first range of viewing angles, wherein said second display screen is further operable to display a third image for viewing from a second range of viewing angles, wherein said second and third images are interlaced, and wherein said first and second display screens overlap.

14. The display device of claim 13, wherein said second range of viewing angles includes at least one viewing angle which is different from said first range of viewing angles.

15. The display device of claim 13, wherein said second and third images are displayed using a respective set of directional pixels.

16. The display device of claim 15, wherein a first set of directional pixels used to display said second image is operable to reduce visibility of said third image from said first range of viewing angles.

17. The display device of claim 15, wherein a second set of directional pixels used to display said third image is operable to reduce visibility of said second image from said second range of viewing angles.

18. The display device of claim 13 further comprising:

an optical component operable to reduce visibility of said second image from said second range of viewing angles, and wherein said optical component is further operable to reduce visibility of said third image from said first range of viewing angles.

19. The display device of claim 18, wherein said optical component is disposed between said first and second display screens.

20. The display device of claim 18, wherein said optical component is selected from a group consisting of a privacy film, an image directing film, an optical directing film, and a lens including a lens stripe pattern.

21. The display device of claim 13 further comprising: a component for enabling viewing of said first image from said first and second ranges of viewing angles.

22. The display device of claim 21, wherein said component is selected from a group consisting of a diffuser and a refractor.