



- (51) International Patent Classification:
B05B 1/00 (2006.01) *A47K 3/00* (2006.01)
- (21) International Application Number:
PCT/IL2017/051279
- (22) International Filing Date:
23 November 2017 (23.11.2017)
- (25) Filing Language: English
- (26) Publication Language: English
- (30) Priority Data:
249680 21 December 2016 (21.12.2016) IL
- (72) Inventor; and
(71) Applicant: ZABARI, Lidor [IL/IL]; 1 HaSar Barzilai St.,
Bat Yam (IL).
- (74) Agent: TURIEL, Avi; PO Box 4025, Tel Mond, 4063178
(IL).

MG, MK, MN, MW, MX, MY, MZ, NA, NG, NI, NO, NZ,
OM, PA, PE, PG, PH, PL, PT, QA, RO, RS, RU, RW, SA,
SC, SD, SE, SG, SK, SL, SM, ST, SV, SY, TH, TJ, TM, TN,
TR, TT, TZ, UA, UG, US, UZ, VC, VN, ZA, ZM, ZW.

- (84) Designated States (unless otherwise indicated, for every kind of regional protection available): ARIPO (BW, GH, GM, KE, LR, LS, MW, MZ, NA, RW, SD, SL, ST, SZ, TZ, UG, ZM, ZW), Eurasian (AM, AZ, BY, KG, KZ, RU, TJ, TM), European (AL, AT, BE, BG, CH, CY, CZ, DE, DK, EE, ES, FI, FR, GB, GR, HR, HU, IE, IS, IT, LT, LU, LV, MC, MK, MT, NL, NO, PL, PT, RO, RS, SE, SI, SK, SM, TR), OAPI (BF, BJ, CF, CG, CI, CM, GA, GN, GQ, GW, KM, ML, MR, NE, SN, TD, TG).

Published:
— with international search report (Art. 21(3))

- (81) Designated States (unless otherwise indicated, for every kind of national protection available): AE, AG, AL, AM, AO, AT, AU, AZ, BA, BB, BG, BH, BN, BR, BW, BY, BZ, CA, CH, CL, CN, CO, CR, CU, CZ, DE, DJ, DK, DM, DO, DZ, EC, EE, EG, ES, FI, GB, GD, GE, GH, GM, GT, HN, HR, HU, ID, IL, IN, IR, IS, JO, JP, KE, KG, KH, KN, KP, KR, KW, KZ, LA, LC, LK, LR, LS, LU, LY, MA, MD, ME,

(54) Title: SELF-SEALING SHOWER HEAD WITH DISINFECTANT

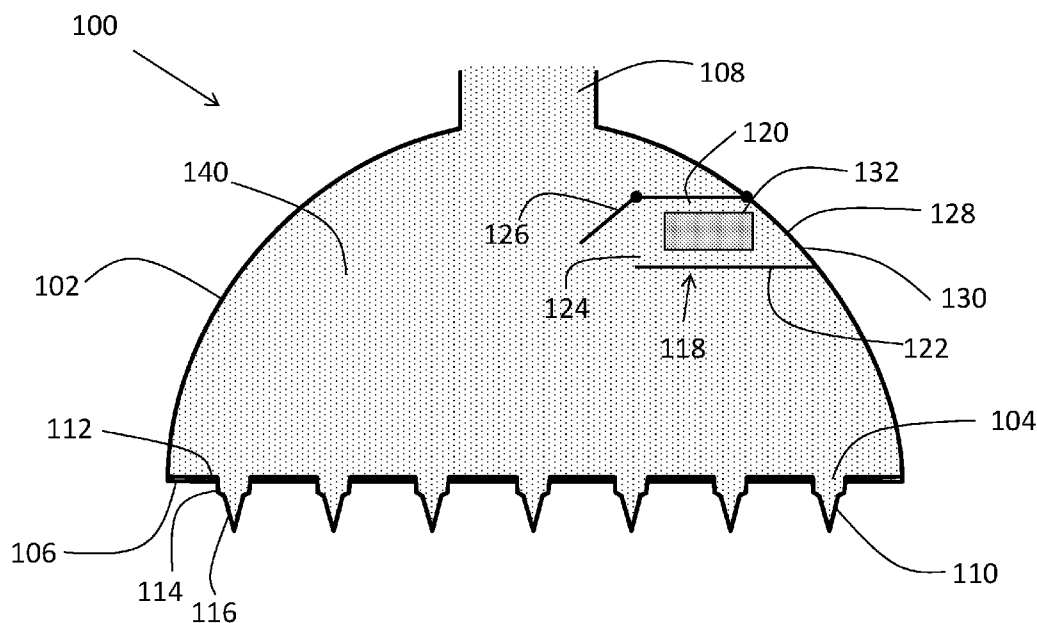

Fig. 1B

(57) Abstract: A shower head comprising: a plurality of outlet nozzles each comprising a valve; and a disinfectant means; wherein the valves open when pressurized water flows into the head and close when there is no pressurized water inflow such that residual water is held inside the head by the closed valves for exposure to the disinfectant means.



SELF-SEALING SHOWER HEAD WITH DISINFECTANT

FIELD OF THE INVENTION

5 The present invention is of a shower head and in particular, such a shower head that prevents bacteria development within the shower head.

BACKGROUND

10 The start and stop of water flow through a shower head results in a mixing of air and water. When water flow is stopped through existing shower heads and faucets, air fills the space within the outlet head. When water flow is renewed the new flow generates turbulence inside the empty shower head which generates small air bubbles. The air, organic materials, water, and lime/stony environment within the shower head provides an excellent environment for development of Legionella
15 bacteria. This bacterium and others may pose a serious danger to at-risk populations especially in hospitals, military camps, hotels, sports centers, and senior citizen residences.

 The danger posed by shower heads is in direct contrast to the need for hygiene that showers and fresh water are supposed to provide and there is therefore a need
20 to keep water systems free of pathogens including Legionella bacteria.

 Water disinfection chemicals and mechanisms rely on the presence of water and therefore do not function when there is no water in the shower system, particularly in the shower head when the water flow is stopped and the water drains from the head. Further, these systems function upstream from the shower head and are
25 difficult to maintain.

 PCT/NL2000/000412 to Antonius Maria Van Remmen discloses a irradiating a liquid with ultraviolet radiation with a converter inside the housing. The ultraviolet disinfection does not change the environment within the outlet part of the shower head that is downstream from the light. Therefore this approach can't prevent
30 legionella bacteria from prospering in the shower head.

US20110150700 to LaPorta and US2659627 to McConnell disclose shower heads which are complex, block the flow of water, require difficult maintenance provided by a technician, and also do not provide disinfection in the actual head.

5 There is therefore a need for improved shower heads and faucets that are simple to manufacture and maintain that allow for disinfection of the head itself such that it will not become a fertile habitat for development of Legionella and other bacteria.

SUMMARY OF THE INVENTION

10 The present invention overcomes the deficiencies of the background art by providing a shower head that prevents the mixing of air and water within the shower head, and also results in a shower head that is always filled with water, even when switched off, thereby providing for disinfection of the water that remains inside the shower head with an integrated disinfection means.

15 The nozzles of the shower head each comprise a backflow valve that is forced open when a pressurized water flow is provided to the head and that close when the pressurized water flow is stopped. The closed valves prevent the entry of air into the head and the valve closure upon removal of pressurized water results in residual water – water that remains inside the shower head. This residual water can be
20 disinfected. This residual water also prevents the inflow of air when the pressurized water flow is renewed and also the turbulence that generates air bubbles. The valves therefore prevent a water/air mixture – thereby preventing the growth of organisms that rely on this water/air mixture.

25 Further, the shower head comprises a disinfectant comprising a disinfectant material or ultraviolet (UV) light or microfilter. The disinfectant is provided so as to be active in the residual water when water flow ceases and not active when water flows through the shower head.

30 Disinfectant material is provided in a chamber constructed with an opening into the internal region of the shower head that is closed when water flows through the shower head and open when water flow stops, thereby bringing the disinfectant material into contact with the residual water to disinfect this residual water. An

opening on the external wall of the shower head enables filling and refilling of the disinfectant material.

A further advantage of the valves is that they reduce water pressure and therefore also water consumption of the shower head.

5 According to some embodiments of the present invention, a shower head comprises: a plurality of outlet nozzles each comprising a valve; and a disinfectant means; wherein the valves open when pressurized water flows into the head and close when there is no pressurized water inflow such that residual water is held inside the head by the closed valves for exposure to the disinfectant means.
10 Preferably, the valves are check valves. Preferably the valves are duckbill valves. Preferably, the valves are umbrella valves.

Preferably the disinfectant means comprises a chamber and wherein the chamber comprises: an inner aperture; a door; and a disinfectant material inside the chamber; wherein the door closes the aperture when pressurized water flows
15 through the head and opens the aperture when there is no pressurized water inflow to expose the residual water to the disinfectant material.

Preferably, the disinfectant material is selected from the group consisting of: a liquid disinfectant material; and a solid disinfectant material. Preferably, the disinfectant material is selected from the group consisting of: ozone; bromine;
20 chlorine; and hypochlorite.

Preferably, the chamber further comprises an outer aperture and outer door. Preferably, the disinfectant means is selected from the group consisting of: an ultraviolet light; a microfilter; and disinfectant material. Optionally, the shower head further comprises a connecting pipe connected at its distal end to an inlet to the
25 head and at its proximal end to a faucet; and an inner pipe positioned within the connecting pipe and connected at its distal end to the disinfectant means and open at its proximal end which is proximal to the faucet; wherein the disinfectant means comprises a pump; wherein the pump, pumps residual water through the disinfectant means, through the inner pipe for circulation through the connecting
30 pipe back into an inner volume of the head, for disinfecting the water. Preferably, the valves prevent air from entering the shower head while allowing outflow of pressurized water.

According to further embodiments of the present invention, a shower head comprises: a plurality of outlet nozzles each comprising a valve; wherein each of the valves open when pressurized water flows into the head and close when there is no pressurized water inflow such that residual water is held inside the head; a
5 disinfectant means in fluid communication with the residual water; and means for preventing fluid communication of the disinfectant means with the pressurized water. Preferably, the disinfectant means is selected from the group consisting of: ultraviolet light; microfilter; liquid disinfectant material; solid disinfectant material; ozone; bromine; chlorine; hypochlorite; and a combination of the above.

10 Preferably, each of the valves are selected from the group consisting of: check valves; backflow valves; duckbill valves; umbrella valves; and a combination of the above. Optionally, the shower head comprises a connecting pipe connected at its distal end to an inlet to the head and at its proximal end to a faucet; and an inner pipe positioned within the connecting pipe and connected at its distal end to the
15 disinfectant means and open at its proximal end which is proximal to the faucet; wherein the disinfectant means comprises a pump; wherein the pump, pumps residual water through the disinfectant means, through the inner pipe for circulation through the connecting pipe back into an inner volume of the head, for disinfecting the residual water. Preferably, the valves prevent air from entering the shower head
20 while allowing outflow of pressurized water.

According to further embodiments of the present invention, a shower head comprises: a plurality of outlet nozzles each comprising a valve; and a disinfectant module; wherein the valves open when pressurized water flows into the head and close when there is no pressurized water inflow such that residual water is held
25 inside the head by the closed valves for exposure to the disinfectant module. Preferably, the disinfectant module comprises at least one of: ultraviolet light; microfilter; liquid disinfectant material; solid disinfectant material; ozone; bromine; chlorine; or hypochlorite.

Preferably, each of the valves are selected from the group consisting of: check
30 valves; backflow valves; duckbill valves; umbrella valves; and a combination of the above. Preferably, the module comprises an outer aperture and outer door. Optionally, the shower head further comprises a connecting pipe connected at its

distal end to an inlet to the head and at its proximal end to a faucet; and an inner pipe positioned within the connecting pipe and connected at its distal end to the disinfectant module and open at its proximal end which is proximal to the faucet; wherein the disinfectant module comprises a pump; wherein the pump, pumps
5 residual water through the disinfectant module, through the inner pipe for circulation through the connecting pipe back into an inner volume of the head, for disinfecting the water. Preferably, the valves prevent air from entering the shower head while allowing outflow of pressurized water.

The term shower head or head as used herein may refer to any outlet of a water
10 distribution system including a spout, faucet, or tap. The shower head as described herein is attached to a pipe or other form of attachment that connects it to a water source as known in the art. While embodiments disclosed herein depict a spherical shower head, this should not be considered limiting and the invention may comprise any shape or dimension of faucet or shower head.

The flow of water into the shower head assumes an attached water source
15 providing water under pressure to generate a flow of water. Similarly the water source may be stopped or closed, halting the supply of pressurized water and the flow into the head. Pressurized water as defined herein is of a pressure found in common residential and commercial water supply systems and may vary between
20 30-150 PSI.

Implementation of the method and system of the present invention involves performing or completing certain selected tasks or steps manually, automatically, or a combination thereof.

Unless otherwise defined, all technical and scientific terms used herein have the
25 same meaning as commonly understood by one of ordinary skill in the art to which this invention belongs. The materials, methods, and examples provided herein are illustrative only and not intended to be limiting.

BRIEF DESCRIPTION OF THE DRAWINGS

30 The invention is herein described, by way of example only, with reference to the accompanying drawings. With specific reference now to the drawings in detail, it is stressed that the particulars shown are by way of example and for purposes of

illustrative discussion of the preferred embodiments of the present invention only, and are presented in order to provide what is believed to be the most useful and readily understood description of the principles and conceptual aspects of the invention. In this regard, no attempt is made to show structural details of the invention in more detail than is necessary for a fundamental understanding of the invention, the description taken with the drawings making apparent to those skilled in the art how the several forms of the invention may be embodied in practice.

In the drawings:

FIGS. 1A and 2A are exemplary illustrations of a shower head comprising a plurality of duckbill valves and disinfectant means according to at least some embodiments of the present invention;

FIGS. 2A and 2B are exemplary illustrations of a shower head comprising a plurality of umbrella valves and disinfectant means according to at least some embodiments of the present invention;

FIGS. 3A and 3B are exemplary illustrations of a shower head comprising alternative disinfectant means according to at least some embodiments of the present invention; and

FIG. 4 is an exemplary illustration of a shower head with disinfectant means for an attached pipe according to at least some embodiments of the present invention.

DESCRIPTION OF THE PREFERRED EMBODIMENTS

The present invention, in at least some embodiments, is of a shower head that uses check valves to contain residual water within the shower head, and also provides for disinfection of this residual water that remains inside the shower head when there is no water flow.

Reference is now made to figures 1A-1B which are exemplary illustrations of a shower head according to at least some embodiments of the present invention. As shown, the shower head 100 comprises a body 102. Body 102 comprises any material common in shower head manufacture such as the non-limiting examples of plastic, stainless steel, or a combination of these or other materials. Body 102 is shown as having a cylindrical form but this should not be considered limiting. Body 102 could be of any shape suitable for a shower head or faucet as known in the art.

Body 102 comprises a plurality of outlets 104 in base 106. Although the cutaway of figures 1A-1B shows seven outlets 104, this should not be considered limiting. Shower 100 preferably comprises as many outlets 104 arranged in any arrangement to suit any current shower head outlet pattern as known in the art. Body 102 further
5 comprises an inlet 108 which is connected via a pipe or connector (not shown) to a source of pressurized water.

Outlets 104 comprise valves 110. Valve 110 may optionally be any type of valve, such as a check valve, that allows flow of pressurized water out of head 100 via outlet 104 but which prevents air from entering head 100. Valve 110 is preferably
10 any check valve or backflow valve. Valve 110 is more preferably a duckbill valve formed from an elastomeric material. Valve 110 comprises flange 112 which is sealably attached to head base 106. Valve saddle 114 extends through outlet 104 and terminates in duckbill 116. Optionally, any combination of valve types may be used.

Shower head 100 comprises disinfectant means 118. Disinfectant means 118
15 may also be referred to herein as disinfectant unit 118 or disinfectant module 118. Disinfectant means 118 comprises a disinfectant material or ultraviolet (UV) light or microfilter. Disinfectant means 118 is provided so as to be active in the residual water when water flow ceases and not active when water flows through the shower
20 head.

In the embodiment of figures 1A, 1B, 2A and 2B, disinfectant means 118
comprises chamber 120. Chamber 120 comprises chamber body 122 which encloses chamber 120. Chamber body has an inner aperture 124 sealed by inner flap 126. When flap 126 is open, volume 140 is fluidly connected to chamber 120 via aperture
25 124. Inner flap 126 is attached to chamber body such that pressurized water flowing through head 100 will force flap 126 to close, whereas the absence of a pressurized water flow will result in flap 126 opening.

Chamber body 122 also comprises external aperture 128 which is sealably closed
with outer door 130. Outer door is formed such that it can be opened or closed to
30 allow filling or refilling of disinfectant material 132 which is placed inside chamber 120. Non-limiting examples of disinfectant material 132 include Ozone (O₃), bromine, chlorine and hypochlorite. Disinfectant material 132 may be provided in a

solid or liquid form. Disinfectant material 132 is provided in a form that allows disinfection to be provided for an extended period of time before disinfectant material 132 needs to be replaced. Disinfectant material 132 is preferably active for 1 to 12 months before needing replacement. The concentration of chlorine disinfectant within residual water is preferably between 0.8ppm and 3ppm. 5 Optionally a combination of disinfectant materials and/or methods are used. As a non-limiting example, chlorine tablets may be combined with a UV light.

Chamber 120 is mounted in shower head 100 such that inner aperture 124 is in fluid communication with inner volume 140 while outer aperture 128 is accessible 10 from outside of head 100 to allow access to chamber 120 for replacement of disinfectant material 132.

In operation, as shown in figure 1A, pressurized water flows into head 100 through inlet 108 in the direction as shown by arrow 150. The pressurized water fills volume 140 and forces duckbills 116 of valves 110 to open such that water flows out 15 of head 100 via outlets 104 in the direction as indicated by arrow 152. The presence of pressurized water flowing through head 100 forces flap 126 into a closed position such that the water in volume 140 is not in communication with chamber 120.

As shown in figure 1B, when the pressurized water is shut off, such as by a tap (not shown) upstream from head 100, water ceases to flow into head 100. Duckbills 20 116 of valves 110 close and water is held in volume 140 to form residual water. The residual water can now be exposed to disinfectant to prevent the growth of bacteria. Additionally, air cannot enter outlets 110 and therefore no air/water mixture is provided and bacterial growth is retarded. The lack of pressurized water results in flap 126 opening such that volume 140 and chamber 120 are in fluid communication. 25 Disinfectant material 132 mixes into the water in volume 140 to kill pathogens that may be in the water. Aperture 124 may be adapted to be larger or smaller to allow greater or lesser mixing of water with disinfectant material 132. Aperture 124 is preferably adjustable to adjust the concentration of disinfectant material 132 in residual water within volume 140. Optionally adjustment is provided by an 30 adjustment lever (not shown) placed next to door 130.

When the pressurized water flow is renewed, as shown in figure 1A, water again flows into head 100 through inlet 108 in the direction as shown by arrow 150. The

water already in volume 140 is added to the pressurized flow which forces duckbills 116 of valves 110 to open such that water flows out of head 100 via outlets 104 in the direction as indicated by arrow 152. The presence of water in volume 140 and the opening of duckbills only when pressurized water is present prevents creation of
5 air bubbles inside volume 140. The presence of pressurized water flowing through head 100 again forces flap 126 into a closed position such that the water in volume 140 is not in communication with chamber 120 and disinfectant material 132 is not released into the flowing water.

Reference is now made to figures 2A-2B which are exemplary illustrations of a
10 shower head according to at least some embodiments of the present invention. The embodiment of figures 2A and 2B is identical to that of figures 1A and 1B with the exception of valves 110. As shown in figures 2A and 2B, the valves used are umbrella valves. Valve 110 is formed from an elastomeric material. Valve 110 comprises flange 112 which is sealably attached to head base 106. Umbrella 117 alternatively
15 allow flow of pressurized water out of head 100 via outlet 104 as shown in figure 2A or seals outlets 104 when no pressurized water flows into head 100. Valves 110 of figures 2A and 2B therefore provide the same result as those in figures 1A and 1B, holding residual water within volume 140 so that residual water can be disinfected by disinfectant means 118 as described above.

Reference is now made to figures 3A-3B which are exemplary illustrations of a
20 shower head according to at least some embodiments of the present invention. Figure 3A and 3B illustrate the shower head of figure 1A, but with an alternative embodiment of disinfectant means 118.

As shown in in figure 3A, disinfectant means 118 comprises ultraviolet (UV) light
25 180, microfilter 184 pump 188, and flow detector 182. UV light 180 and pump 188 comprise a power source (not shown). When flow detector 182 detects a flow of water in volume 140, light 180 and pump 188 are turned off to conserve power. When flow detector 182 detects that no flow is present, such as when water is not flowing through head 100, pump 188 is activated to draw water through disinfectant
30 means 118 in the direction shown by arrow 186. When no flow is present UV light 180 is also activated. Pump 188 therefore draws water from volume 140 through disinfectant means 118 to pass UV light 180 and microfilter 184 to thereby disinfect

the residual water inside volume 140. The power source such as a battery may be replaced or charged via outer door 130. Additionally microfilter 184 may be cleaned or replaced via outer door 130. Optionally the embodiment shown in figure 3A comprises only UV light 180 without microfilter 184, or comprises only microfilter 184 without UV light 180.

As shown in figure 3B, disinfectant means 118 comprises chamber 120 which comprises chamber body 122 which encloses chamber 120. Chamber body has an inner aperture 124 sealed by inner door or nozzle 190. When nozzle 190 is open, volume 140 is fluidly connected to chamber 120 via aperture 124. Inner nozzle 190 is adapted such that pressurized water flowing through head 100 will force nozzle 190 to close, whereas the absence of a pressurized water flow will result in nozzle 190 opening.

Chamber body 122 also comprises external aperture 128 which is sealably closed with outer door 130. Outer door is formed such that it can be opened or closed to allow filling or refilling of liquid disinfectant material 132 which is placed inside chamber 120. Liquid disinfectant material 132 is provided in a form that allows disinfection to be provided for an extended period of time before disinfectant material 132 needs to be replaced. Disinfectant material 132 is preferably active for 1 to 12 months before needing replacement.

Chamber 120 is mounted in shower head 100 such that inner aperture 124 is in fluid communication with inner volume 140 while outer aperture 128 is accessible from outside of head 100 to allow access to chamber 120 for replacement of disinfectant material 132.

Reference is now made to figure 4 which is exemplary illustrations of a shower head according to at least some embodiments of the present invention. Figure 4 illustrates the shower head of any of the previous embodiments, but with an extension pipe to disinfect the pipe 402 connected to head 100.

As shown in in figure 4, pipe 402 is connected at its distal end to head inlet 108. Pipe 402 is connected at its proximal end to faucet 406. Inner pipe 404 is connected at its distal end to disinfectant means 118. The proximal end of inner pipe 404 is open and in fluid communication with the water inside pipe 402.

Disinfectant means 118 comprises a pump 188, and flow detector 182. Disinfectant means 118 also comprises any of the disinfectant mechanisms such as disinfectant material, UV light or microfilter as described in the embodiments presented above. Pump 188 comprises a power source (not shown). When flow detector 182 detects a flow of water in volume 140, pump 188 is turned off to conserve power. When flow detector 182 detects that no flow is present, such as when water is not flowing through head 100, pump 188 is activated to draw water through disinfectant means 118 in the direction shown by arrows 408.

When faucet 406 is closed and water flow through head 100 is ceased, valves 110 will close as described above, creating residual water in volume 140. Residual water will extend and also remain in volume 440 within pipe 402. Driven by pump 188, water will therefore circulate as shown by arrows 408, through disinfectant means 118, through inner pipe 404, out of the proximal end of pipe 404, and returning through pipe 402 into volume 140. Therefore all of residual water in volumes 140, 440 and inside inner pipe 404 will be disinfected.

It should be appreciated that the above described methods and apparatus may be varied in many ways, including omitting or adding steps, changing the order of steps and the type of devices used. It should be appreciated that different features may be combined in different ways. In particular, not all the features shown above in a particular embodiment are necessary in every embodiment of the invention. Further combinations of the above features are also considered to be within the scope of some embodiments of the invention.

Therefore combinations of the embodiments of figures 1A, 1B, 2A, 2B, 3A and 3B are possible. As a non-limiting example, the valve of figure 2A may be combined with the chamber of figure 3B. Optionally other such combinations are possible.

While the invention has been described with respect to a limited number of embodiments, it will be appreciated that many variations, modifications and other applications of the invention may be made.

30

What is claimed is:

1. A shower head comprising:
 - a. a plurality of outlet nozzles each comprising a valve; and
 - 5 b. a disinfectant means;wherein said valves open when pressurized water flows into said head and close when there is no pressurized water inflow such that residual water is held inside said head by said closed valves for exposure to said disinfectant means, wherein said disinfectant means comprises a chamber and wherein
10 said chamber comprises: an inner aperture; a door; and a disinfectant material inside said chamber; wherein said door closes said aperture when pressurized water flows through said head and opens said aperture when there is no pressurized water inflow to expose said residual water to said disinfectant material.
- 15 2. The shower head of claim 1 wherein said valves are check valves.
3. The shower head of claim 1 wherein said valves are duckbill valves.
4. The shower head of claim 1 wherein said valves are umbrella valves.
5. The shower head of any one of the above claims wherein said disinfectant material is selected from the group consisting of:
20 a. a liquid disinfectant material;
 b. a solid disinfectant material;
 c. ozone;
 d. bromine;
 e. chlorine;
25 f. hypochlorite;
 g. an ultraviolet light; and
 h. a microfilter.
6. The shower head of any one of the above claims wherein said chamber further comprises an outer aperture and outer door.
- 30 7. The shower head of any one of the above claims, further comprising:
 - a. a connecting pipe connected at its distal end to an inlet to said head and at its proximal end to a faucet; and

b. an inner pipe positioned within said connecting pipe and connected at its distal end to said disinfectant means and open at its proximal end which is proximal to said faucet;

wherein said disinfectant means comprises a pump; wherein said pump, pumps residual water through said disinfectant means, through said inner pipe for circulation through said connecting pipe back into an inner volume of said head, for disinfecting said water.

5

8. The shower head of any one of the above claims wherein said valves prevent air from entering said shower head while allowing outflow of pressurized water.

10

9. A shower head comprising:

a. a plurality of outlet nozzles each comprising a valve; wherein each of said valves open when pressurized water flows into said head and close when there is no pressurized water inflow such that residual water is held inside said head;

15

b. a disinfectant means in fluid communication with said residual water; and

c. means for preventing fluid communication of said disinfectant means with said pressurized water.

20

10. The shower head of claim 9 wherein said disinfectant means is selected from the group consisting of:

a. ultraviolet light;

b. microfilter;

c. liquid disinfectant material;

d. solid disinfectant material;

e. ozone;

f. bromine;

g. chlorine;

h. hypochlorite; and

i. a combination of the above.

25

30

11. The shower head of any one of claim 9 or 10 wherein each of said valves are selected from the group consisting of:
- a. check valves;
 - b. backflow valves;
 - 5 c. duckbill valves;
 - d. umbrella valves; and
 - e. a combination of the above.
12. The shower head of any one of claims 9-11, further comprising:
- a. a connecting pipe connected at its distal end to an inlet to said head and at its proximal end to a faucet; and
 - 10 b. an inner pipe positioned within said connecting pipe and connected at its distal end to said disinfectant means and open at its proximal end which is proximal to said faucet;
- wherein said disinfectant means comprises a pump; wherein said pump, pumps residual water through said disinfectant means, through said inner pipe for circulation through said connecting pipe back into an inner volume of said head, for disinfecting said residual water.
13. The shower head of any one of claims 9-12 wherein said valves prevent air from entering said shower head while allowing outflow of pressurized water.
- 20
14. A shower head comprising:
- a. a plurality of outlet nozzles each comprising a valve; and
 - b. a disinfectant module;
- wherein said valves open when pressurized water flows into said head and close when there is no pressurized water inflow such that residual water is held inside said head by said closed valves for exposure to said disinfectant module, wherein said module comprises an outer aperture and outer door.
- 25
15. The shower head of claim 14 wherein said disinfectant module comprises at least one of:
- 30 a. ultraviolet light;
 - b. microfilter;
 - c. liquid disinfectant material;

- d. solid disinfectant material;
 - e. ozone;
 - f. bromine;
 - g. chlorine; or
 - 5 h. hypochlorite.
16. The shower head of either one of claims 14 or 15 wherein each of said valves are selected from the group consisting of:
- a. check valves;
 - b. backflow valves;
 - 10 c. duckbill valves;
 - d. umbrella valves; and
 - e. a combination of the above.
17. The shower head of any one of claims 14-16, further comprising:
- a. a connecting pipe connected at its distal end to an inlet to said head and at its proximal end to a faucet; and
 - 15 b. an inner pipe positioned within said connecting pipe and connected at its distal end to said disinfectant module and open at its proximal end which is proximal to said faucet;
- wherein said disinfectant module comprises a pump; wherein said pump, pumps residual water through said disinfectant module, through said
- 20 inner pipe for circulation through said connecting pipe back into an inner volume of said head, for disinfecting said water.
18. The shower head of any one of claims 14-17 wherein said valves prevent air from entering said shower head while allowing outflow of pressurized water.

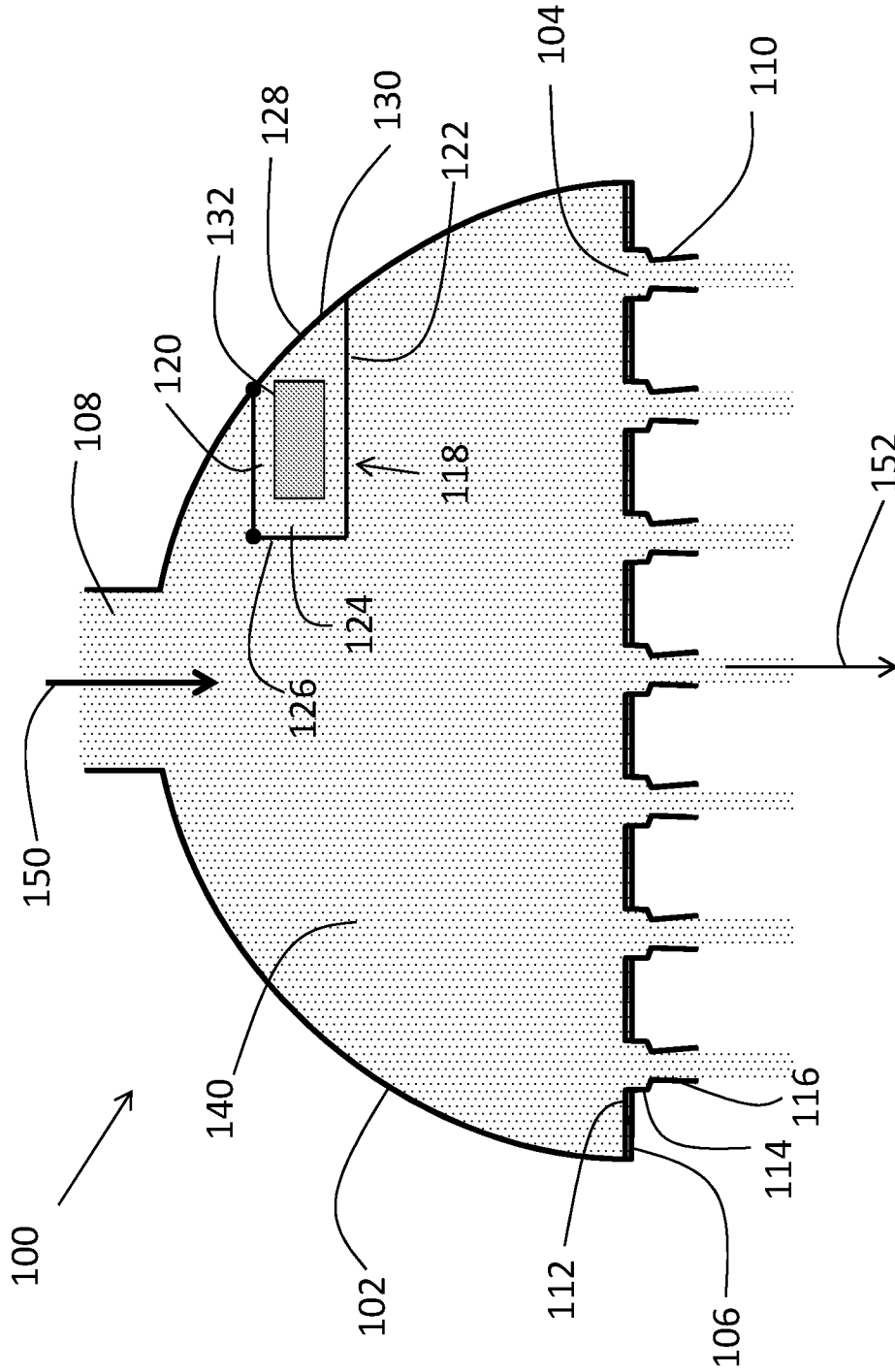

Fig. 1A

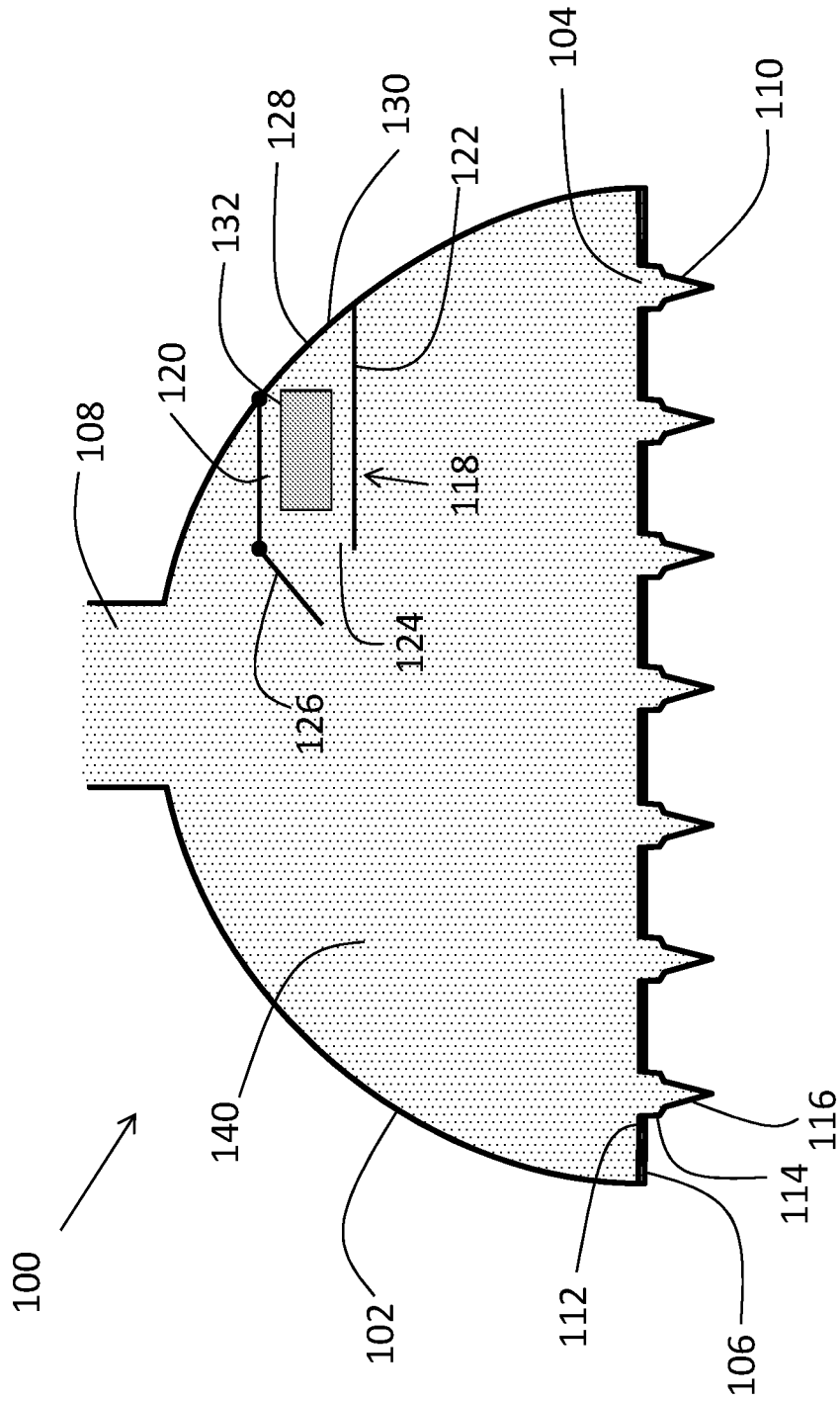

Fig. 1B

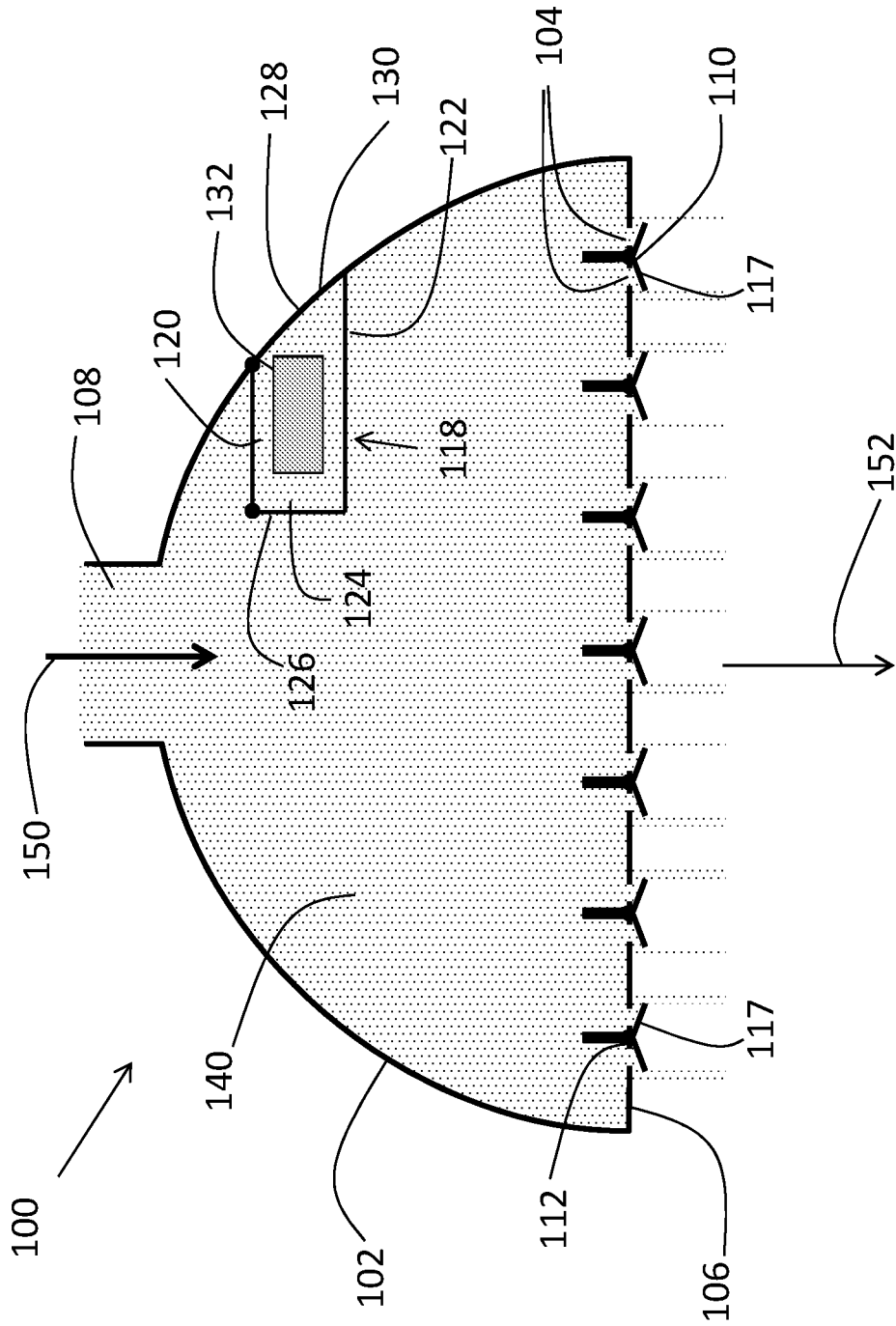

Fig. 2A

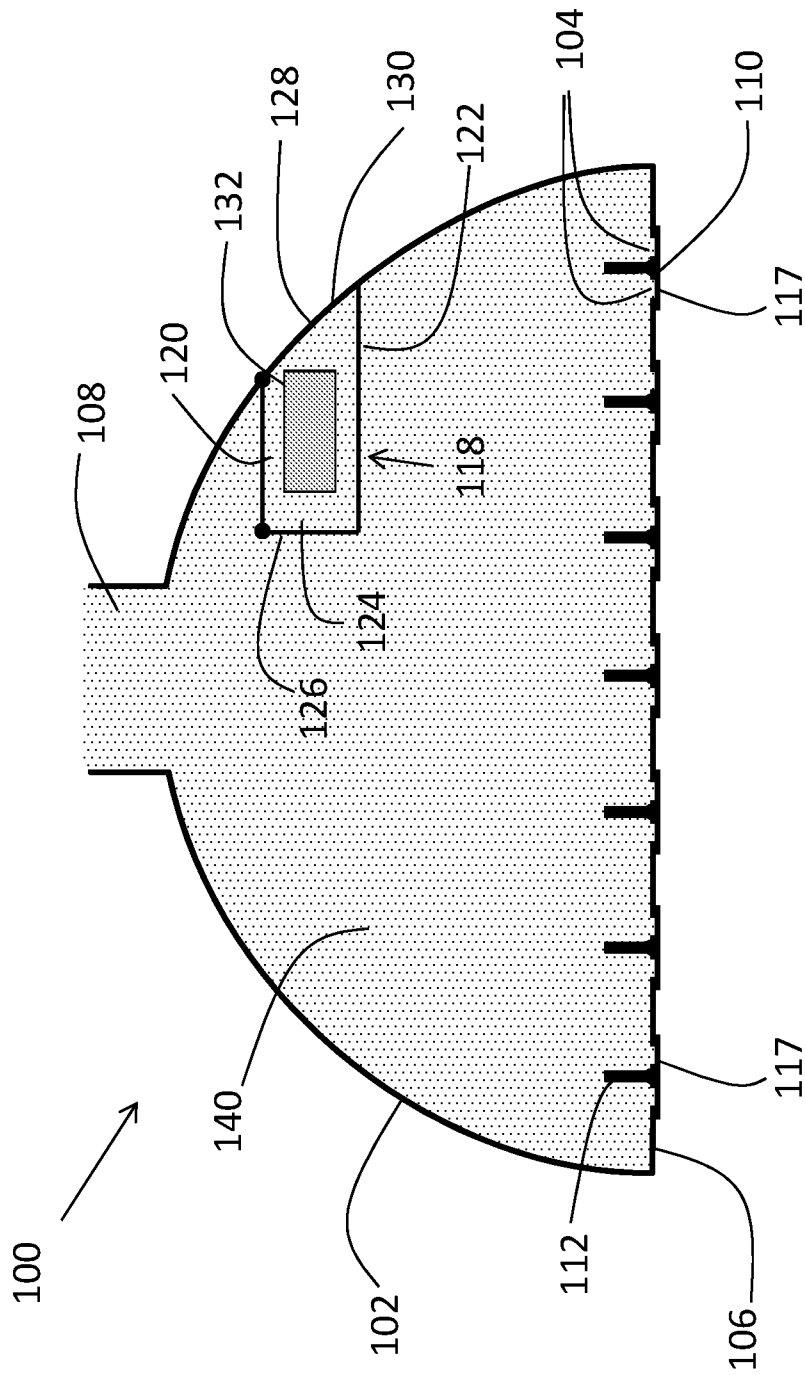

Fig. 2B

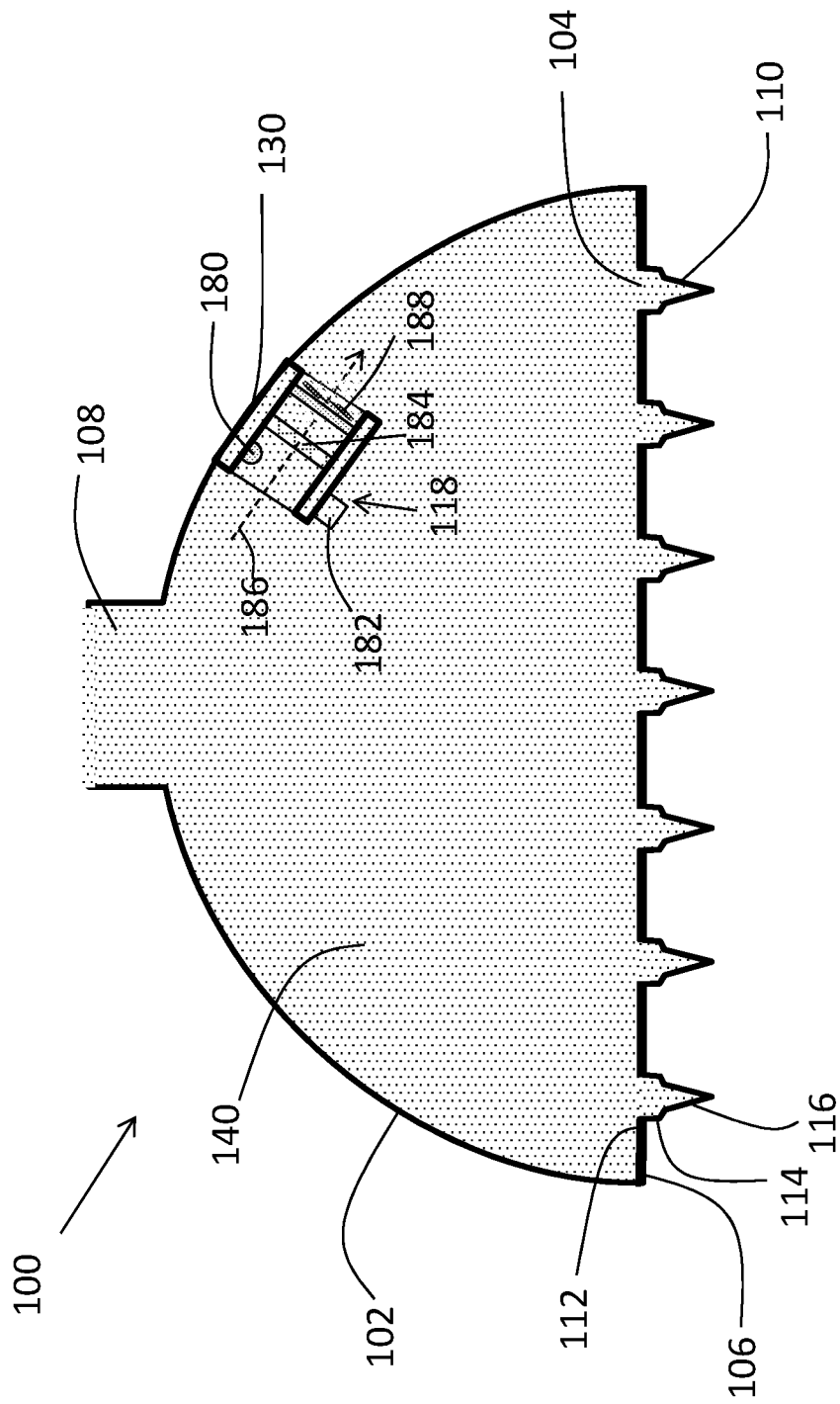

Fig. 3A

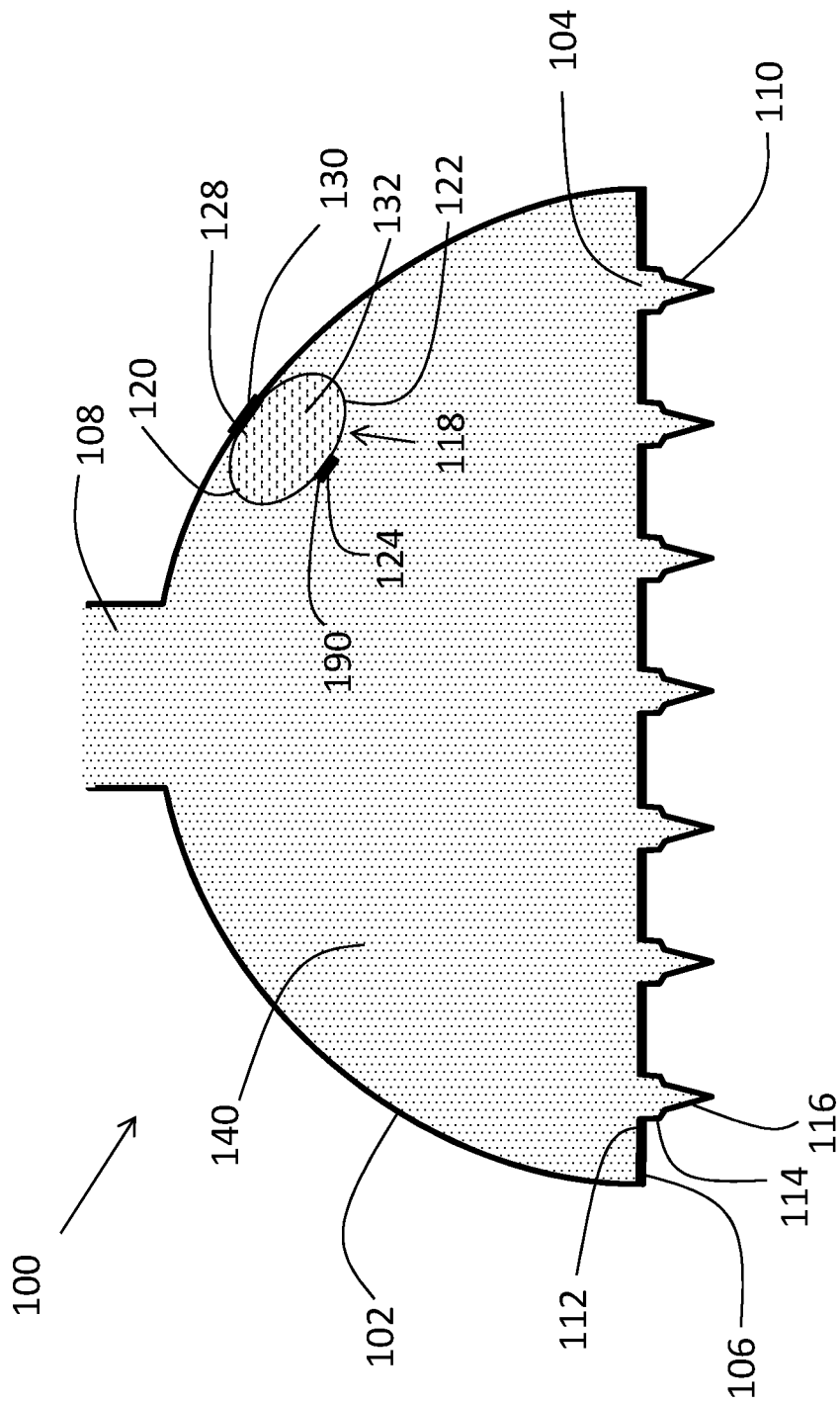

Fig. 3B

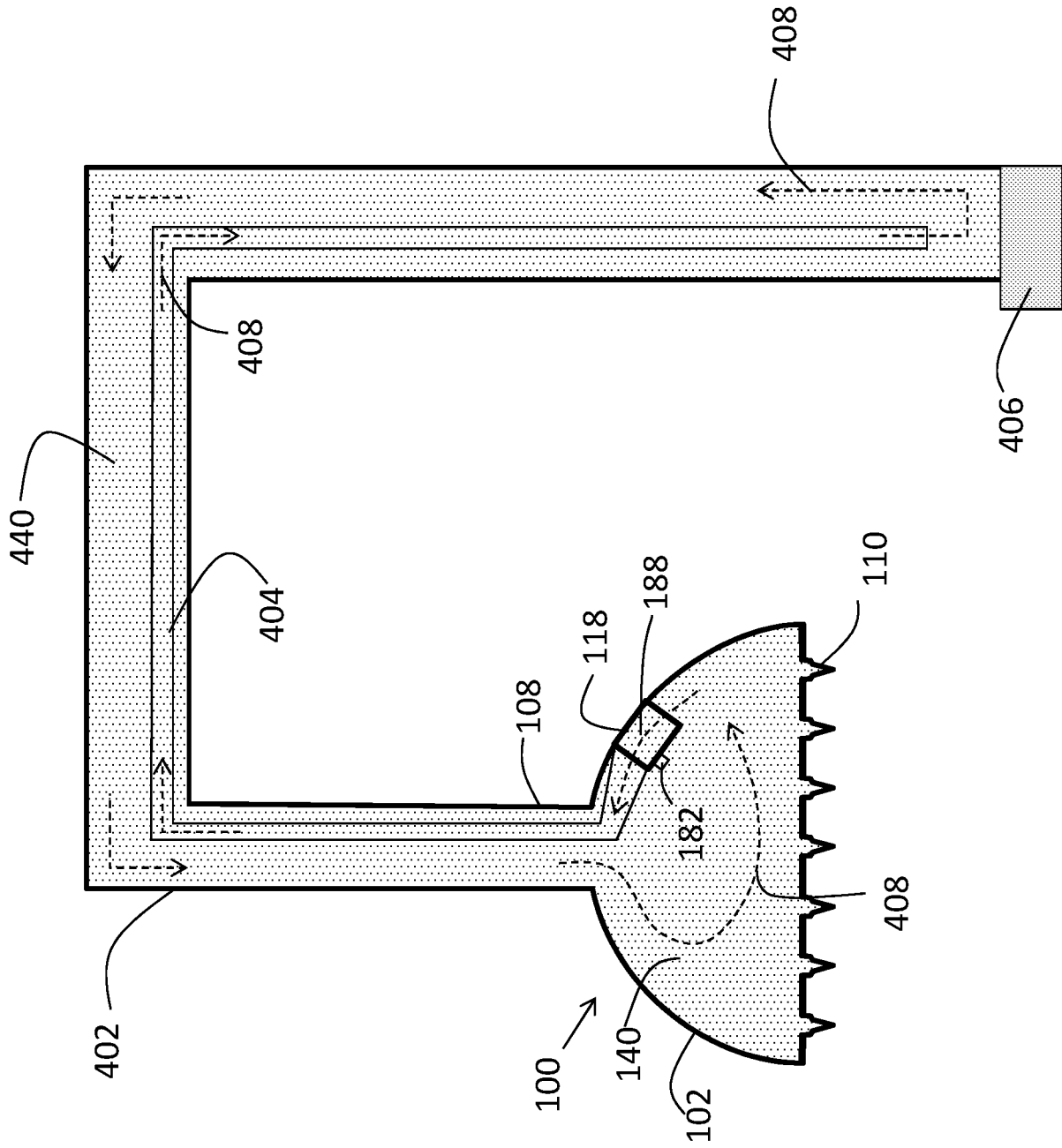

Fig. 4

INTERNATIONAL SEARCH REPORT

International application No.

PCT/IL2017/051279

A. CLASSIFICATION OF SUBJECT MATTER

IPC (2018.01) B05B 1/00, A47K 3/00

According to International Patent Classification (IPC) or to both national classification and IPC

B. FIELDS SEARCHED

Minimum documentation searched (classification system followed by classification symbols)

IPC (2018.01) B05B 1/18, A47K 3/28, C02F 1/28, A61L 2/235, B01D 35/02

Documentation searched other than minimum documentation to the extent that such documents are included in the fields searched

Electronic data base consulted during the international search (name of data base and, where practicable, search terms used)

Databases consulted: Derwent Innovation, Orbit

Search terms used: disinfect, shower, head, chamber, sprinkler, nozzle, umbrella, duck, spout, piston, valve, aperture

C. DOCUMENTS CONSIDERED TO BE RELEVANT

Category*	Citation of document, with indication, where appropriate, of the relevant passages	Relevant to claim No.
A	DE 3107808 A1 GROHE ARMATUREN FRIEDRICH [DE] 16 Sep 1982 (1982/09/16) Entire Document	1-18
A	JP 2001008849 A INAX CORP 16 Jan 2001 (2001/01/16) Entire Document	1-18
A	US 2008135062 A1 3M INNOVATIVE PROPERTIES CO 12 Jun 2008 (2008/06/12) Entire Document	1-18
A	US 2012055888 A1 HUNTER ALASTAIR J [GB]; WILKINSON TIMOTHY J [GB]; PALL EUROPE LTD [GB] 08 Mar 2012 (2012/03/08) Entire Document	1-18

 Further documents are listed in the continuation of Box C. See patent family annex.

* Special categories of cited documents:

"A" document defining the general state of the art which is not considered to be of particular relevance

"E" earlier application or patent but published on or after the international filing date

"L" document which may throw doubts on priority claim(s) or which is cited to establish the publication date of another citation or other special reason (as specified)

"O" document referring to an oral disclosure, use, exhibition or other means

"P" document published prior to the international filing date but later than the priority date claimed

"T" later document published after the international filing date or priority date and not in conflict with the application but cited to understand the principle or theory underlying the invention

"X" document of particular relevance; the claimed invention cannot be considered novel or cannot be considered to involve an inventive step when the document is taken alone

"Y" document of particular relevance; the claimed invention cannot be considered to involve an inventive step when the document is combined with one or more other such documents, such combination being obvious to a person skilled in the art

"&" document member of the same patent family

Date of the actual completion of the international search

07 Feb 2018

Date of mailing of the international search report

11 Feb 2018

Name and mailing address of the ISA:

Israel Patent Office

Technology Park, Bldg.5, Malcha, Jerusalem, 9695101, Israel

Facsimile No. 972-2-5651616

Authorized officer

CHOVER Nimrod Israel

Telephone No. 972-5651692

INTERNATIONAL SEARCH REPORT
Information on patent family members

International application No.
PCT/IL2017/051279

Patent document cited search report	Publication date	Patent family member(s)	Publication Date
DE 3107808 A1	16 Sep 1982	DE 3107808 A1	16 Sep 1982
		DE 3107808 C2	21 Feb 1991
JP 2001008849 A	16 Jan 2001	JP 2001008849 A	16 Jan 2001
US 2008135062 A1	12 Jun 2008	US 2008135062 A1	12 Jun 2008
		EP 2101828 A2	23 Sep 2009
		TW 200833378 A	16 Aug 2008
		WO 2008073681 A2	19 Jun 2008
		WO 2008073681 A3	04 Sep 2008
US 2012055888 A1	08 Mar 2012	US 2012055888 A1	08 Mar 2012
		CA 2751904 A1	08 Mar 2012
		CA 2751904 C	06 Jan 2015
		CN 102401164 A	04 Apr 2012
		CN 102401164 B	08 Jul 2015
		EP 2428262 A1	14 Mar 2012
		JP 2012057458 A	22 Mar 2012
		JP 5495394 B2	21 May 2014
		KR 20160055751 A	18 May 2016
		KR 101719613 B1	24 Mar 2017
		KR 20120026011 A	16 Mar 2012
		SG 179340 A1	27 Apr 2012
		US 2012055886 A1	08 Mar 2012
		US 9745206 B2	29 Aug 2017
		US 2017239680 A1	24 Aug 2017
		US 9878921 B2	30 Jan 2018