



(11) **EP 1 918 664 A2**

(12) **EUROPEAN PATENT APPLICATION**

(43) Date of publication:  
**07.05.2008 Bulletin 2008/19**

(51) Int Cl.:  
**F25D 17/06<sup>(2006.01)</sup> F25D 31/00<sup>(2006.01)</sup>**

(21) Application number: **07118653.0**

(22) Date of filing: **17.10.2007**

(84) Designated Contracting States:  
**AT BE BG CH CY CZ DE DK EE ES FI FR GB GR HU IE IS IT LI LT LU LV MC MT NL PL PT RO SE SI SK TR**  
Designated Extension States:  
**AL BA HR MK RS**

(72) Inventors:  
• **Galkin, Igor**  
**398024, Lipetsk (RU)**  
• **Fioretti, Gabriele**  
**I-60044, Fabriano (AN) (IT)**

(30) Priority: **24.10.2006 IT TO20060767**

(74) Representative: **Dini, Roberto**  
**Metroconsult S.r.l.**  
**Via Sestriere 100**  
**10060 None (Torino) (IT)**

(71) Applicant: **Indesit Company S.p.A.**  
**60044 Fabriano (AN) (IT)**

(54) **Refrigerating appliance**

(57) The invention relates to a refrigerating appliance, in particular for domestic use, the refrigerated compartment (2) of which contains a cell (9) thermally insulated by a separating septum (7).

The cell thus prearranged can contain hot items, such as cooked foods in plates, saucepans or the like, having a temperature significantly higher than room temperature, without making the temperature in the refrigerated compartment (2) rise above a preset level.

In double-door "no-frost" type refrigerators, the cell (9) is cooled internally by air coming from the freezer compartment (3).

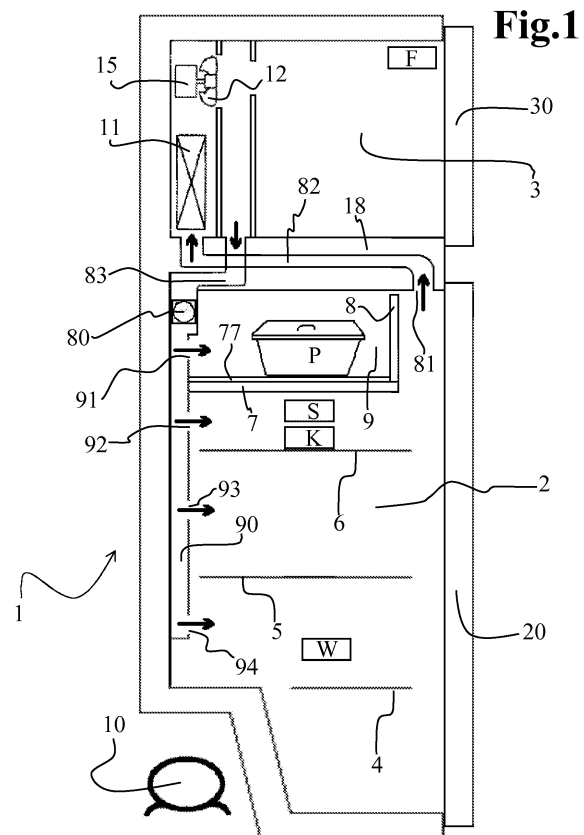

**EP 1 918 664 A2**

## Description

**[0001]** The present invention relates to a refrigerating appliance according to the preamble of the first claim, and typically applies to household refrigerators used for preserving and/or storing foodstuffs.

**[0002]** Many known refrigerating appliances comprise at least one internal compartment adapted to contain foodstuffs and to be cooled by means of a refrigerating circuit. Said internal compartment may be a refrigerated one, i.e. kept at an average temperature between 0°C and 10°C, suitable for preserving fresh foodstuffs.

**[0003]** Household refrigerating appliances are also known which comprise a refrigerator compartment and a freezer compartment, the latter being arranged on top of the refrigerator compartment: such refrigerating appliances are commonly called "double-door refrigerators" by those skilled in the art of household refrigeration.

**[0004]** Finally, refrigerating appliances are also known wherein heat is subtracted from the foodstuffs by forced convection, i.e. by providing cold air circulation inside the refrigerator compartment: these refrigerating appliances therefore stand out from static-type refrigerating appliances (i.e. without forced convection) and are commonly called "no-frost refrigerators" by those skilled in the art.

**[0005]** Generally, the above-mentioned known refrigerating appliances suffer from the drawback that their refrigerator compartment cannot contain hot items such as food cooked in containers (plates, heat-resistant pans, etc.) having a temperature significantly higher than room temperature.

**[0006]** In fact, hot items placed in the refrigerator compartment would cause some areas thereof to reach temperatures above 10°C, thus making the appliance no longer compliant with the requirements of the ISO 15502 standard and no longer capable of ensuring a correct preservation of the foodstuffs kept in the refrigerator compartment. It should be reminded that the ISO 15502 standard specifies the essential characteristics of static and no-frost refrigerating appliances for domestic use, as well as the correct methods for checking said characteristics.

**[0007]** It follows that the user cannot put food in the refrigerator compartment as soon as it is cooked they are done, since it will be necessary to wait for the food to cool down almost to room temperature. It should be remarked that the cooling time of cooked food in a room environment can be rather long.

**[0008]** The above-mentioned drawback is felt even more if the users of the refrigerating appliance are accustomed to cooking large quantities of food to be eaten at different times within a span of a few days, or if they have the habit of cooking food, e.g. soups, having such a consistency to determine a low area/volume ratio.

**[0009]** Patent application EP1564514 describes a household refrigerating appliance comprising a variable-speed compressor driven by the electronic control system based on the temperature detected by sensors lo-

cated inside the refrigerator compartment. When the sensors detect a considerable rise of temperature caused by hot food placed in the refrigerator compartment, the electronic control system will switch the compressor to maximum power.

**[0010]** A refrigerating appliance according to EP1564514 suffers from the drawback of requiring a very complex control and of being very costly. There are also sound reasons to doubt that it can comply with the parameters specified by the ISO 15502 standard when the temperature of the food placed in the refrigerator is much higher than room temperature.

**[0011]** Patent application JP2003-014354 describes a container made of insulating material and suitable for containing hot food just cooked. The food is first placed in the container (having a lid also made of insulating material), which in turn is placed in a household refrigerating appliance. According to JP2003-014354, the insulating material used for manufacturing the container prevents the hot food from altering the preservation conditions of other foodstuffs.

**[0012]** However, such a container has the manifest drawback of a rather limited capacity, so that it can only contain certain types of food, due to its rigid construction. It is also quite bulky, so that it cannot be housed in all refrigerating appliances.

**[0013]** It is the object of the present invention to provide a refrigerating appliance which is particularly suitable for obtaining a quick cooling of hot foodstuffs and which complies with the current standards in terms of preservation temperatures.

**[0014]** In other words, the invention aims at providing an appliance wherein the presence of hot items in the refrigerator compartment will not cause any alterations in the preservation conditions of other foodstuffs stored in the same appliance.

**[0015]** It is a further object of the present invention to provide a household refrigerating appliance which can overcome the inherent drawbacks of the above-described ones, being particularly cheap to produce and easy to control in addition to including a high-capacity hot-food zone in the refrigerator compartment.

**[0016]** The present invention is based on the general idea of providing a refrigerating appliance in which a refrigerated compartment includes a thermally insulated cell, the inside of which is preferably cooled: thus it will be possible to store hot foodstuffs, or any foodstuffs having a temperature much higher than room temperature, in the cell, without the heat of said foodstuffs radiating in the refrigerated compartment.

**[0017]** Such an appliance eliminates any incompatibility issues between the preservation conditions of the foodstuffs stored in the refrigerated compartment and the applicable standards.

**[0018]** According to a preferred embodiment, the cell is defined by a separating septum which separates it from the rest of the refrigerator compartment.

**[0019]** The technical features and the advantages of

the present invention will become apparent from the following detailed description provided with reference to the annexed drawings, which illustrate a merely exemplifying and non-limiting embodiment of the present invention, wherein:

- Fig. 1 shows a sectional side view of a refrigerating appliance according to the present invention;
- Fig. 2 shows the temperature/time curves of some hot foodstuffs and some standard preservation packs contained in a refrigerating appliance according to the present invention.

**[0020]** Fig. 1 shows a refrigerator-freezer 1, i.e. a household refrigerating appliance comprising at least two inner compartments 2 and 3 having different temperatures, so that at least two different foodstuffs preservation states are allowed.

**[0021]** In this example, compartment 2 is a refrigerator compartment, i.e. it is suitable for preserving fresh foodstuffs at a temperature between 0 °C and 10 °C, whereas freezer compartment 3 is suitable for preserving frozen foodstuffs; the freezer compartment is located on top of refrigerator compartment 2, in accordance with the typical configuration of double-door refrigerators.

**[0022]** Both compartments 2 and 3 are closed by respective doors: in particular, door 20 closes refrigerator compartment 2, while door 30 closes freezer compartment 3.

**[0023]** The representation of refrigerator 1 in Fig. 1 shows some items which are commonly found inside a refrigerator compartment, such as shelves 4, 5 and 6 arranged at different heights, but for simplicity's sake it does not show other typical items contained in a refrigerator compartment, such as the lower drawer for vegetables or the lighting device of refrigerator compartment 2, which may advantageously be turned on in accordance with the method described in patent application W02006/095217. Likewise, Fig. 1 does not show any additional devices which may be housed in refrigerator compartment 2 of refrigerator-freezer 1, such as an air purification device in refrigerator compartment 2, or a special container adapted to preserve vacuum-packed foodstuffs.

**[0024]** Double-door refrigerator-freezer 1 shown in Fig. 1 is a no-frost type refrigerating appliance, i.e. the heat is removed by forced convection through circulation of cold air in refrigerator compartment 2 and in freezer compartment 3.

**[0025]** The cooling power is generated by compressor 10, which is a part of a refrigerating circuit that also comprises evaporator coil 11 (the other components of the refrigerating circuit are not shown in Fig. 1, since they are well known to those skilled in the art of household refrigeration; for the same reason, the drawing does not show the defrosting device commonly associated with evaporator coil 11), which is located in the rear of freezer compartment 3.

**[0026]** The air cooled by evaporator coil 11 is circulated by fan 12, when the latter is driven by motor 15, and is partly released in freezer compartment 3 and partly conveyed to refrigerator compartment 2 through supply duct 83, obtained in separating wall 18 between refrigerator compartment 2 and freezer compartment 3. Supply duct 83 is connected to distribution means 90 for distributing cold air into refrigerator compartment 2, which comprise venting means 91, 92, 93 and 94 located at different heights in refrigerator compartment 2 (in this example, distribution means 90 consist of a conduit, while venting means 91, 92, 93 and 94 consist of a series of cold air outlets or apertures).

**[0027]** A gate valve 80 is connected between supply duct 83 and distribution means 90; said gate valve 80, which is traditionally present in double-door refrigerating appliances and is known in the art of household refrigeration as "damper", adjusts the flow rate of the cold air supplied to refrigerator compartment 2 according to the temperature sensed therein.

**[0028]** The cold air is warmed by the heat subtracted by forced convection from the foodstuffs contained in refrigerator compartment 2 and then returns to the evaporating pack 11 through return section 81 and intake duct 82, obtained in separating wall 18 between refrigerator compartment 2 and freezer compartment 3.

**[0029]** Refrigerating appliance 1 comprises a cell 9 for cooling hot foodstuffs, the inner temperature of which is lower than that in refrigerator compartment 2; cell 9 is located in the upper portion of the latter and is separated from the rest of the refrigerator compartment by a thermoinsulating separating septum 7 which makes it suitable for storing hot foods.

**[0030]** Separating septum 7 comprises a layer made from plastic material, preferably polystyrene or polyurethane, which works as a thermoinsulating layer since, as known, this kind of material is a good insulator against heat transfer by conduction.

**[0031]** The thickness of the plastic layer is preferably between 10 mm and 20 mm, more preferably about 15 mm: in fact, a plastic layer this thick can provide an effective insulating action even in the presence of temperature differences between cell 9 and the remaining volume of refrigerator compartment 2 of about 100°C (though not less effective, thicker layers would be bulkier and would imply a greater reduction in the capacity of the refrigerator compartment 2). Alternatively, separating septum 7 may be an insulating panel having at least one inner layer in a vacuum.

**[0032]** The top surface of separating septum 7 may be coated with a protective coating 77 made from a material capable of withstanding temperatures much higher than room temperature. Said protective coating 77 allows the user to place hot food into cell 9 still in the container used for cooking (e.g. if the hot food is a soup, the cooking container may be a metal pot with a lid), without having first to transfer the hot food from the cooking container to another suitable container, such as a Pirex<sup>®</sup> glass

container. The material used for protective coating 77 is preferably heat-resistant rubber capable of withstanding temperatures much higher than room temperature.

**[0033]** If, as in Fig. 1, refrigerating appliance 1 is of the no-frost type and comprises distribution means 90 for distributing cold air in refrigerator compartment 2, there will be cold air venting means 91 in cell 9. Thus the foodstuffs contained in the cell will be hit by a cold air flow which will tend to remove the thermal content of the foodstuffs by forced convection in a rather quick and effective manner.

**[0034]** Cell 9 is closed by an element 8, i.e. a panel or a door, as described below, which also defines the capacity thereof; said capacity is preferably about 15 litres.

**[0035]** Closing element 8 prevents the air that has become significantly warmer in cell 9 after having exchanged heat with the hot foodstuffs from diffusing in refrigerator compartment 2, in which case it would change the preservation conditions of the foodstuffs stored therein, so that refrigerating appliance 1 would no longer be compliant with the standards specifying food preservation temperatures.

**[0036]** Furthermore, closing element 8 is also used for allowing the user of refrigerating appliance 1 to gain access to cell 9 in order to store or remove foodstuffs; to this end, element 8 is movable and/or removable, so that the user can open cell 9 through it.

**[0037]** According to a first configuration of refrigerating appliance 1, the separating septum 7 is a fixed component of refrigerating appliance 1.

**[0038]** In such a configuration, cell 9 can be opened through a rotary movement of closing element 8: for example, closing element 8 may be provided in the form of a flap which, when door 20 is open, can be turned about one side constrained to separating septum 7 or to another component of refrigerating appliance 1 (e.g. the side walls of refrigerator compartment 2).

**[0039]** According to a second configuration of the cell 9, which is alternative to and preferable over the preceding one, the separating septum 7 is a removable component.

**[0040]** In this case, closing element 8 is a panel associated with separating septum 7, thus forming a drawer: in this manner, the inside of cell 9 becomes easily accessible by pulling out said drawer either partially or totally with respect to refrigerator compartment 2.

**[0041]** It should also be pointed out that a variant may be conceived for this second embodiment as well; in fact, front closing element 8 may be pivoted (instead of fixed) as in the first embodiment, although separating septum 7 can still be extracted like a normal drawer. Of course, the pivoting mechanism of element 8 shall allow it to stop in the vertical condition of Fig. 1.

**[0042]** Fig. 1 shows the positioning of hot foodstuffs and of a number of standard preservation packs in a refrigerator prototype according to the present invention derived from the Ariston MTM 1911 F double-door no-frost refrigerating appliance. It should be reminded that

a standard preservation pack is a test element having a parallelepiped shape, made from a material having physical characteristics almost identical to those of beef, in the geometrical centre of which there is a thermocouple for detecting the inner temperature of the pack.

**[0043]** In cell 9 there is a hot food P, in particular consisting of 3 litres of soup. The hot food P is contained in a heat-resistant Pyrex® glass pan with a lid, resting on the separating septum 7. The temperature of hot food P is monitored through a suitable temperature probe.

**[0044]** A number of standard preservation packs have been placed in refrigerating appliance 1 in order to verify the compliance with the requirements of the ISO 15502 preservation standard even in the presence of hot food P. In particular, said preservation packs are:

- i) a first preservation pack S, located in refrigerator compartment 2 at a distance of 15 mm from the lower surface of separating septum 7;
- ii) a second preservation pack K, located on the shelf of refrigerator compartment 2 which is closest to separating septum 7 (i.e. shelf 6);
- iii) a third preservation pack W, located in the refrigerator compartment at a significant distance from cell 9 (precisely in the space between shelves 4 and 5), and
- iv) a fourth preservation pack F, located in the least cold area of freezer compartment 3, i.e. the uppermost portion of the volume of freezer compartment 3 adjoining door 30.

**[0045]** Fig. 2 is a diagram which includes a number of curves showing the progress of temperature TP of hot food P, temperature TS of first preservation pack S, temperature TK of second preservation pack K, temperature TW of third preservation pack W, and temperature TF of fourth preservation pack F as a function of time H.

**[0046]** In the diagram, time H=0 represents the moment when hot food P is correctly placed into cell 9 of refrigerating appliance 1; at time H=0, the temperature probe associated with hot food P detects a temperature of 86.1 °C and all preservation packs are at their respective operating temperature. Temperature TP of hot food P decreases rapidly, due to continuous heat removal by forced convection, so that room temperature (T=25°C) is reached after approximately 4 hours and 30 minutes. This shows how refrigerating appliance 1 according to the present invention, which allows the user to place hot foodstuffs directly into refrigerator compartment 2, achieves the advantage of providing a reduction in the cooling time of hot food P.

**[0047]** The temperature of the standard preservation packs placed in refrigerator compartment 2 turns out to be constantly complying with the ISO 15502 preservation standard as hot food P is being cooled. In fact, at no time their temperature rises above 10°C, the maximum value of temperature TS of preservation pack S being 9°C, the maximum value of temperature TK of preservation pack

K being 7.8°C, and the maximum value of temperature TW of preservation pack W being 4.9°C. Nor is freezer compartment 3 affected by the thermal load placed in cell 9 to such an extent as to exceed the parameters of the ISO 15502 standard. In fact, temperature TF of preservation pack F, located in the least cold area of freezer compartment 3, reaches a maximum temperature of -16°C, while said standard requires the average operating temperature in freezer compartment 3 to be approximately -18°C and the temperature reached during transient periods (for instance due to door 30 being opened or to evaporator coil 11 being defrosted) not to exceed -15°C (transient periods may last up to 6h).

**[0048]** The progress of temperature TF clearly shows that, during hot food P cooling time, compressor 10 operates continuously instead of intermittently, until most of the thermal load applied to refrigerating appliance 1 by hot food P placed in cell 9 has been dissipated.

**[0049]** According to a variant of the present invention, refrigerating appliance 1 is controlled electronically and comprises electronic control means operationally connected to refrigerating power generation means (represented by compressor 10 in Fig. 1). Electronically controlled refrigerating appliance 1 also comprises sensor means and user interface means, both of which are operationally connected to the electronic control means. The wording "sensor means" refers to one or more devices (temperature probes, humidity probes, etc.) suitable for detecting the value of at least one physical quantity pertaining to the operation of refrigerating appliance 1, whereas the wording "interface means" refers to one or more devices (push-buttons, knobs, LEDs, displays, etc.) suitable for allowing the user to set a parameter related to the operation of refrigerating appliance 1 and/or for displaying at least one piece of information pertaining to the operation of refrigerating appliance 1.

**[0050]** At least two different modes of operation of refrigerating appliance 1 are possible:

- i) a first mode of operation according to which periods when compressor 10 is on alternate with periods when the compressor is off (this first mode is particularly suitable for the normal operation of refrigerating appliance 1);
- ii) a second mode of operation according to which compressor 10 remains constantly on (this second mode is particularly suitable after the introduction of a high thermal load, such as hot food P, into refrigerator compartment 2 or freezer compartment 3).

**[0051]** The switching from the first to the second mode of operation may take place as follows:

- i) upon a user's command, by means of a suitable selection device included in the user interface means of refrigerating appliance 1. For example, in the non-limiting case that said selection device is a push-button, after having placed hot food P into cell 9 the

user presses the push-button in order to turn on compressor 10 continuously, or

ii) automatically, if the electronically controlled refrigerating appliance 1 comprises at least one temperature sensor which detects a temperature rise in cell 9 due to the introduction of hot food P. The electronic control means, which are operationally connected to the temperature sensor, control compressor 10 for continuous operation. Preferably, a first preset temperature value is stored in the electronic control means: when the temperature detected by said sensor rises and reaches the first preset temperature value, the first mode of operation is automatically switched to the second mode of operation. In addition to electronically controlled refrigerating appliances, the automatic switching from the first to the second mode of operation may be implemented to advantage also in electromechanical refrigerating appliances.

**[0052]** The reverse switching from the second to the first mode of operation may take place:

- i) after a predetermined period of time (e.g. approximately 5 hours), said second mode of operation having a predetermined duration. In this case, the electronic control means include a timer device which makes them capable of counting the time elapsed after the activation of the second mode of operation. The time elapsed after the activation of the second mode of operation is compared with the preset duration time stored in the electronic control means, or
- ii) on the basis of the temperature detected by said temperature sensor, which senses a temperature reduction in cell 9 due to the dissipation of a large quantity of the thermal load introduced into cell 9. Preferably, the electronic control means store a second preset temperature value which is lower than said first preset value: when the temperature detected by the sensor decreases and reaches the second preset temperature value, the second mode of operation is automatically switched to the first mode of operation. Temperature may advantageously be used as a parameter determining the automatic switching from the second to the first mode of operation in both electronically controlled and electromechanical refrigerating appliances.

**[0053]** The present invention offers several advantages.

**[0054]** In the first place, the user of refrigerating appliance 1 can put foodstuffs into refrigerator compartment 2 as soon as it is done, without having to wait for it to cool down to room temperature. This anticipated action (which does not jeopardize the compliance with the parameters defined by the ISO 15502 standard, nor does it change the preservation conditions of the other foodstuffs contained in refrigerator compartment 2) elimi-

notes the risk that the user forgets to put the food into refrigerator compartment 2 once it has cooled down to room temperature, in which case the food would remain too long outside refrigerating appliance 1, where it would be much more subject to bacteria and other pathogenic and/or deteriorating agents.

**[0055]** In the second place, refrigerating appliance 1 allows the user to cook large quantities of foodstuffs, such as soups or other foodstuffs having similar consistency, to be eaten within a span of a few days, since cell 9 has a large capacity and ensures optimal preservation conditions.

**[0056]** In the third place, refrigerating appliance 1 requires neither any critical electronic control nor features such as a variable-speed compressor, which would inevitably imply higher production costs.

**[0057]** In the fourth place, refrigerating appliance 1 allows the user to avoid using specific containers for storing hot foodstuffs in refrigerating appliance 1, said containers generally suffering from the drawbacks of not being suitable for containing all kinds of foodstuffs, of having a rather limited capacity, and of taking up much space inside refrigerating appliance 1.

**[0058]** In this frame, it should be pointed out that the solution of the above-described example of the invention, according to which the cell is obtained by applying a separating septum 7 into refrigeration compartment 2, can also be easily implemented without any particular difficulty in existing refrigerators.

**[0059]** In other terms, it is possible to provide existing refrigerators with cell 9 at a low cost, because in said solution cell 9 is delimited at its sides and top by the walls of refrigerator compartment 2, and is delimited at the bottom and in front by separating septum 7 and closing element 8.

**[0060]** It should however be underlined that, according to a further possible variant of the invention, front closing element 8 may be complemented by side walls arranged along the edge of separating septum 7, thus forming a drawer.

**[0061]** In other words, in this variant cell 9 would be defined by the drawer thus formed, the side walls of which shall preferably be thermally insulated through layers of polystyrene, polyurethane or the like, just like separating septum 7.

**[0062]** The invention so conceived is clearly suited to industrial application. It may also be subject to many other changes and variations without departing from the scope of the inventive concept; all details thereof may be replaced by technically equivalent items. The present invention has been described herein with reference to particular embodiment examples, but it is clear that many changes may be made thereto by those skilled in the art without departing from the protection scope defined by the appended claims.

## Claims

1. Refrigerating appliance comprising at least one refrigerated compartment (2) and one cell (9) arranged in said compartment (2), **characterized in that** the cell (9) is thermally insulated and can contain hot items, such as foodstuffs placed in containers or the like and having a temperature significantly higher than room temperature, without making the temperature in the refrigerated compartment (2) rise above a preset level.
2. Appliance according to claim 1, wherein the compartment (2) is a refrigerator compartment and the cell (9) is cooled internally.
3. Appliance according to claim 1 or 2, wherein the cell (9) is cooled by air circulating therein.
4. Appliance according to claim 3, comprising a freezer compartment (3) which is in fluid communication with the cell (9) for providing cold air circulation therein.
5. Appliance according to any of the preceding claims, wherein the cell (9) comprises a bottom wall (7) which is used as a support for hot items and is thermally insulated by means of a layer of a material such as polystyrene, polyurethane or the like.
6. Appliance according to claim 5, wherein the insulating material layer preferably has a thickness between 10 mm and 20 mm.
7. Appliance according to claim 6, wherein the surface of the wall (7) facing the inside of the cell (9) is coated with a protective layer (77) capable of withstanding the high temperatures of the items placed in the cell.
8. Appliance according to any of the preceding claims, comprising a separating septum (7) which separates the cell (9) from the rest of the refrigerated compartment (2) and which is also the wall of the cell (9) on which hot items are laid.
9. Appliance according to claim 8, wherein the separating septum (7) is fixed with respect to the refrigerated compartment (2), and the cell (9) also comprises a front closing element (8) associated with the separating septum (7) and movable in relation thereto.
10. Appliance according to claim 9, wherein the closing element (8) can be turned like a horizontally pivoted door.
11. Appliance according to any of claims 1 to 8, wherein the separating septum (7) can be extracted from the refrigerated compartment (2), and the cell (9) also

comprises a front closing element (8) associated with the separating septum (7) and fixed relative to it, thus substantially forming a drawer.

12. Appliance according to any of claims 1 to 8, wherein the separating septum (7) can be extracted from the refrigerator compartment (2), and the cell (9) also comprises a front closing element (8) associated with the separating septum (7) and movable relative to it, thus turning like a horizontally pivoted door from a closed condition, in which it is perpendicular to the separating septum (7), to an open condition, in which it is turned over relative to it. 5  
10
13. Appliance according to any of claims 1 to 8, wherein the separating septum (7) can be extracted from the refrigerator compartment (2), and side walls are pre-arranged on the edge thereof which define, together with the septum (7), a drawer closed frontally by a closing element (8). 15  
20
14. Appliance according to claim 13, wherein the side walls along the edge of the separating septum (7) are thermally insulated by a layer of polystyrene, polyurethane or the like. 25
15. Refrigerating appliance according to any of the preceding claims, having a refrigerating circuit for cooling the refrigerated compartment (2), comprising a compressor (10), electronic control means operationally connected to the compressor (10), sensor means operationally connected to the electronic control means for detecting the temperature in the cell (9), and user interface means operationally connected to the electronic control means for allowing a user to enter commands. 30  
35
16. Appliance according to claim 15, wherein the user interface means comprise a selection device for switching the compressor (10) from a first mode of operation according to which it is intermittently on to a second mode of operation according to which it is continuously on. 40
17. Appliance according to claim 16, wherein the selection device is actuated manually through a push-button or any other equivalent element. 45
18. Appliance according to claim 16, wherein the switching between said first and second modes of operation of the compressor (10), and vice versa, is controlled by the electronic control means. 50
19. Appliance according to claim 18, wherein the switching between said first and second modes of operation, and vice versa, is controlled by the control means based on the temperature detected in the cell (9) by the sensor means. 55

**Fig.1**

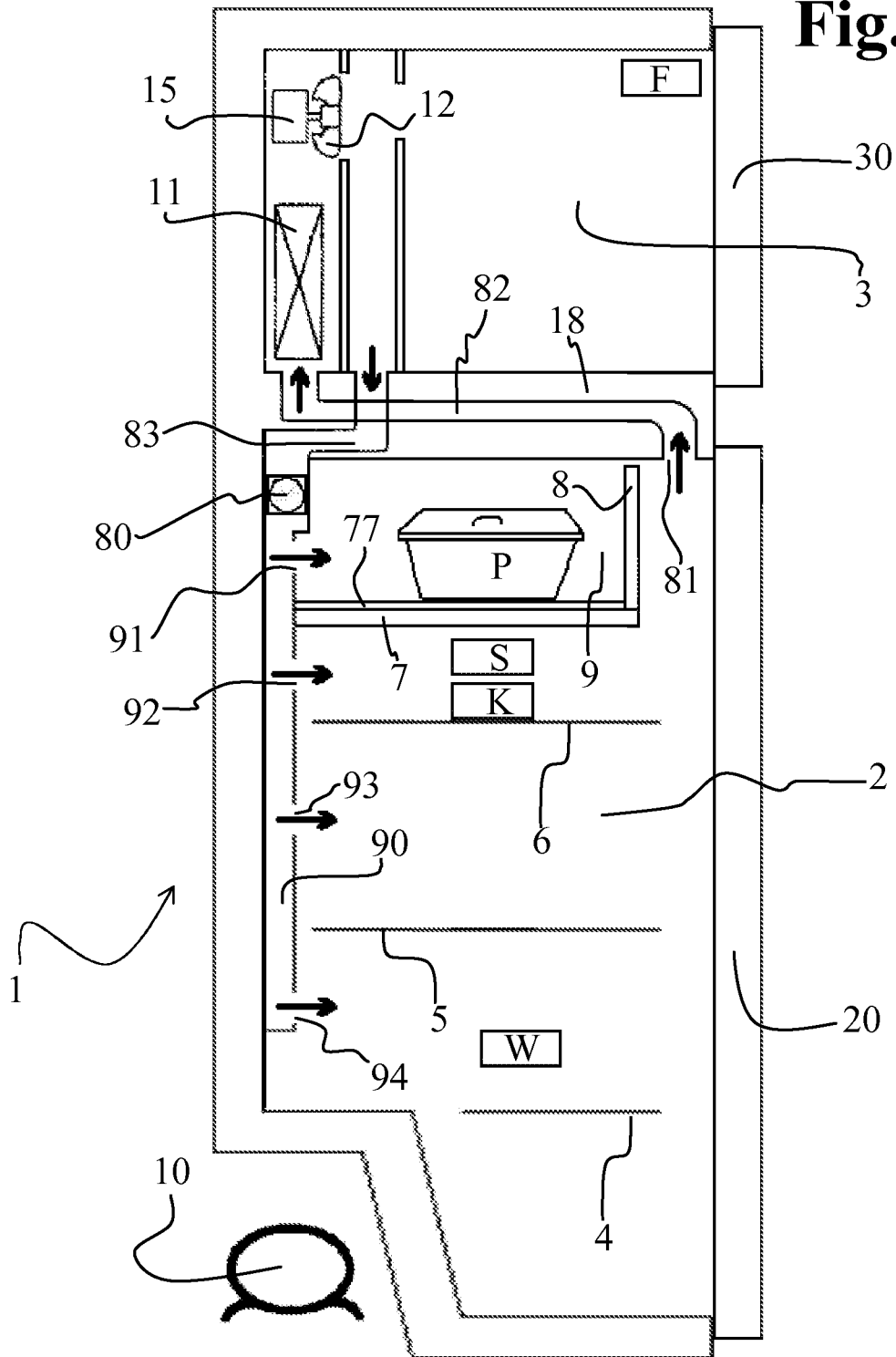

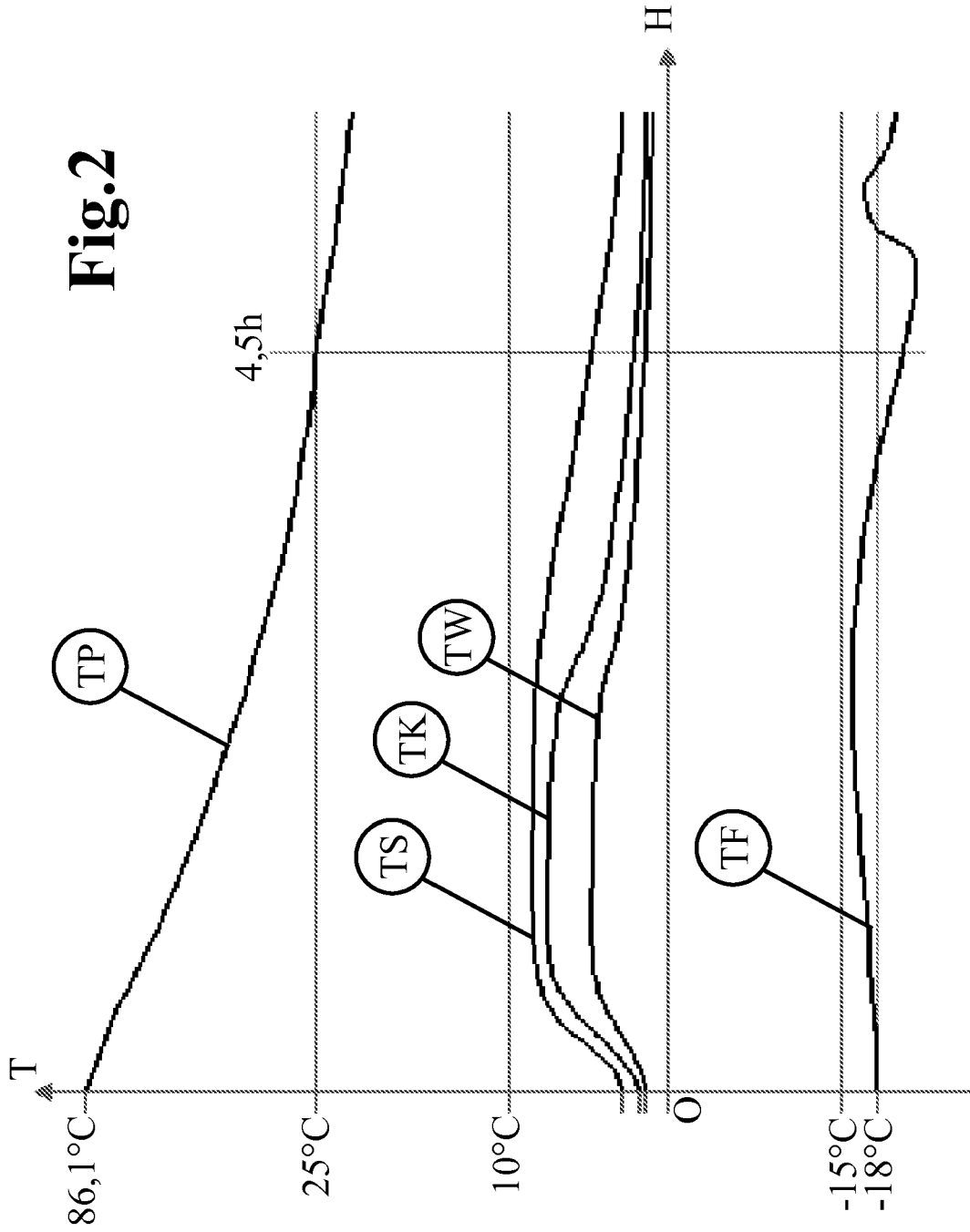

**REFERENCES CITED IN THE DESCRIPTION**

*This list of references cited by the applicant is for the reader's convenience only. It does not form part of the European patent document. Even though great care has been taken in compiling the references, errors or omissions cannot be excluded and the EPO disclaims all liability in this regard.*

**Patent documents cited in the description**

- EP 1564514 A [0009] [0010]
- JP 2003014354 A [0011] [0011]
- WO 2006095217 A [0023]