



USOORE36985E

United States Patent [19] **Trainham, III et al.**

[11] E **Patent Number: Re. 36,985**
[45] **Reissued Date of Patent: Dec. 12, 2000**

[54] **ANODE USEFUL FOR ELECTROCHEMICAL CONVERSION OF ANHYDROUS HYDROGEN HALIDE TO HALOGEN GAS**

[75] Inventors: **James Arthur Trainham, III**, Greenville, Del.; **Clarence Garland Law, Jr.**, Franklin, Tenn.; **John S. Newman**, Kensington, Calif.

[73] Assignee: **E. I. du Pont de Nemours and Company**, Wilmington, Del.

[21] Appl. No.: **09/093,535**
[22] Filed: **Jun. 8, 1998**

Related U.S. Patent Documents

Reissue of:
[64] Patent No.: **5,580,437**
Issued: **Dec. 3, 1996**
Appl. No.: **08/246,909**
Filed: **May 20, 1994**

U.S. Applications:

- [63] Continuation-in-part of application No. 08/156,196, Nov. 22, 1993, Pat. No. 5,411,641.
- [51] **Int. Cl.⁷** **C25B 1/24**
- [52] **U.S. Cl.** **205/621; 205/622; 205/252; 205/265; 205/266; 205/291; 205/292; 205/293**
- [58] **Field of Search** **205/621, 622, 205/252, 265, 266, 291, 292, 293**

[56] **References Cited**

U.S. PATENT DOCUMENTS

3,453,187	7/1969	Slatin	204/69
3,729,395	4/1973	Caron et al.	204/59 R
4,139,447	2/1979	Faron et al.	204/239
4,169,025	9/1979	Needes	204/98
4,191,618	3/1980	Coker et al.	204/98
4,210,501	7/1980	Dempsey et al.	204/128
4,224,121	9/1980	Dempsey et al.	204/98
4,294,671	10/1981	Balko	204/128
4,311,568	1/1982	Balko	204/128
4,595,579	6/1986	Prudhon et al.	423/487
4,655,887	4/1987	Oda et al.	204/283
4,959,132	9/1990	Fedkiw, Jr.	204/101
5,223,102	6/1993	Fedkiw, Jr. et al.	204/78

FOREIGN PATENT DOCUMENTS

1179631	12/1984	Canada	.
1195949	10/1985	Canada	.
0319489	6/1989	European Pat. Off.	.
2413481	7/1979	France	.
2312297	9/1974	Germany	204/59 R
56-36873	8/1981	Japan	.
0363424	12/1931	United Kingdom	423/483
0861978	3/1961	United Kingdom	204/128

OTHER PUBLICATIONS

Appleby, A. J. et al., *Fuel Cell Handbook*, Van Nostrand Reinhold, New York, Chapter 10, pp. 284-312. No date available.

Jewulski, J. R. et al. *Solid-State Proton Conductors—Final Report*, For U.S. DOE, Office of Fossil Energy, Morgantown Energy Tech. Center, Morgantown WV, Institute of Gas Technology, Chicago, Illinois, Dec. 1990. No date available.

Minz, F. R., "HLC—Electrolysis—Technology for Recycling Chlorine," Bayer AG, Conference on Electrochemical Processing, Innovation & Progress, Glasgow, Scotland, UK, Apr. 21-23, 1993.

Takenaka H., et al., "Solid Polymer Electrolyte Water Electrolysis", *Int. J. Hydrogen Energy*, 7(5), pp. 397-403, 1982. No month available.

Wilson, M. S., et al., "High Performance Catalyzed Membranes of Ultra-low Pt Loadings for Polymer Electrolyte Fuel Cells", *J. Electrochem. Soc.*, 139(2), Feb. 1992.

Primary Examiner—Kishor Mayekar

[57] **ABSTRACT**

A particular anode comprising an electrochemically active material selected from the group [comprising] consisting of the oxides of the elements tin, germanium and lead and mixtures comprising at least one of the respective oxides of such elements is useful in an electrochemical cell for the direct production of essentially dry halogen gas from essentially anhydrous halogen halide, or in a process for such production of essentially dry halogen gas. This cell or process may be used to produce halogen gas such as chlorine, bromine, fluorine and iodine from a respective anhydrous hydrogen halide, such as hydrogen chloride, hydrogen bromide, hydrogen fluoride and hydrogen iodide.

16 Claims, 2 Drawing Sheets

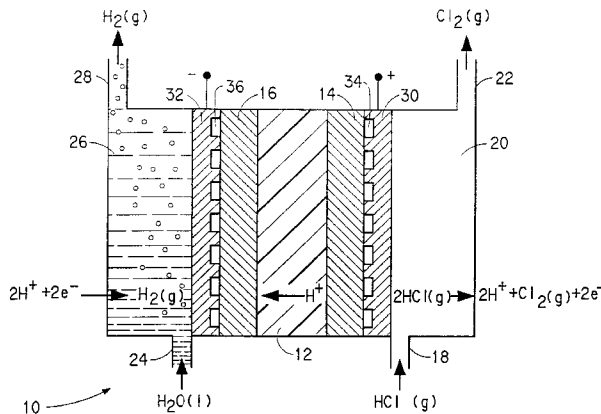

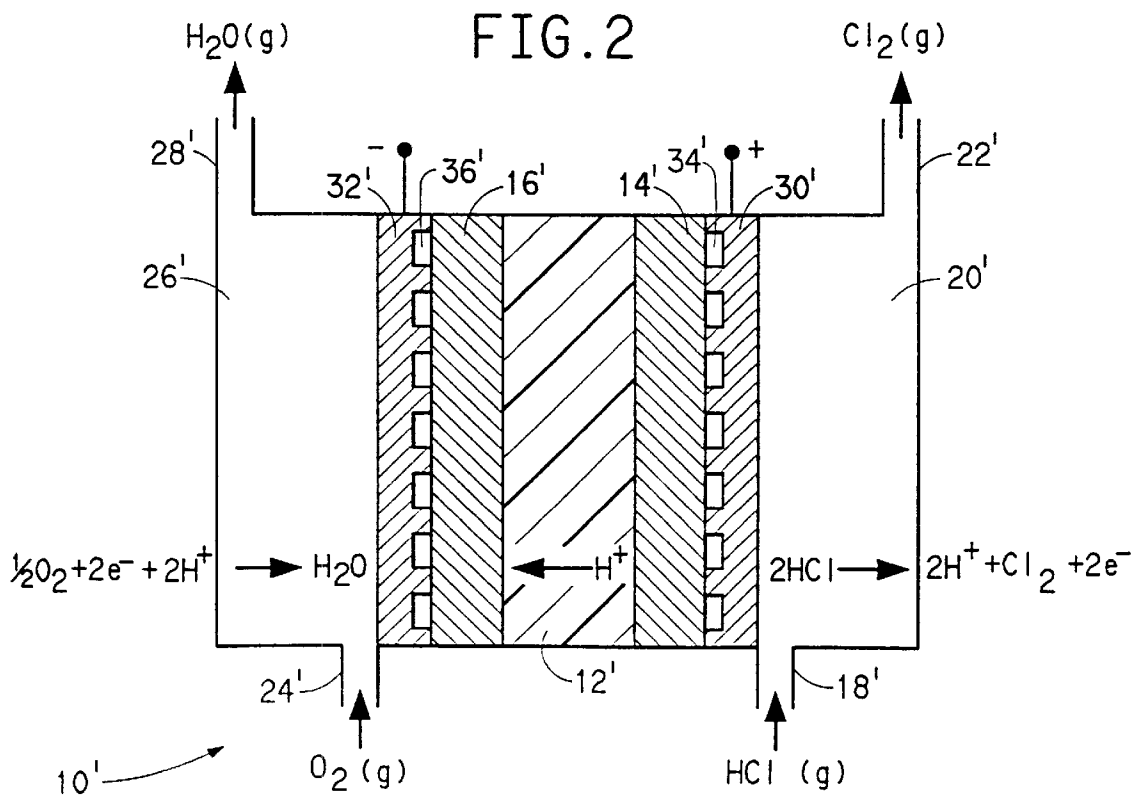
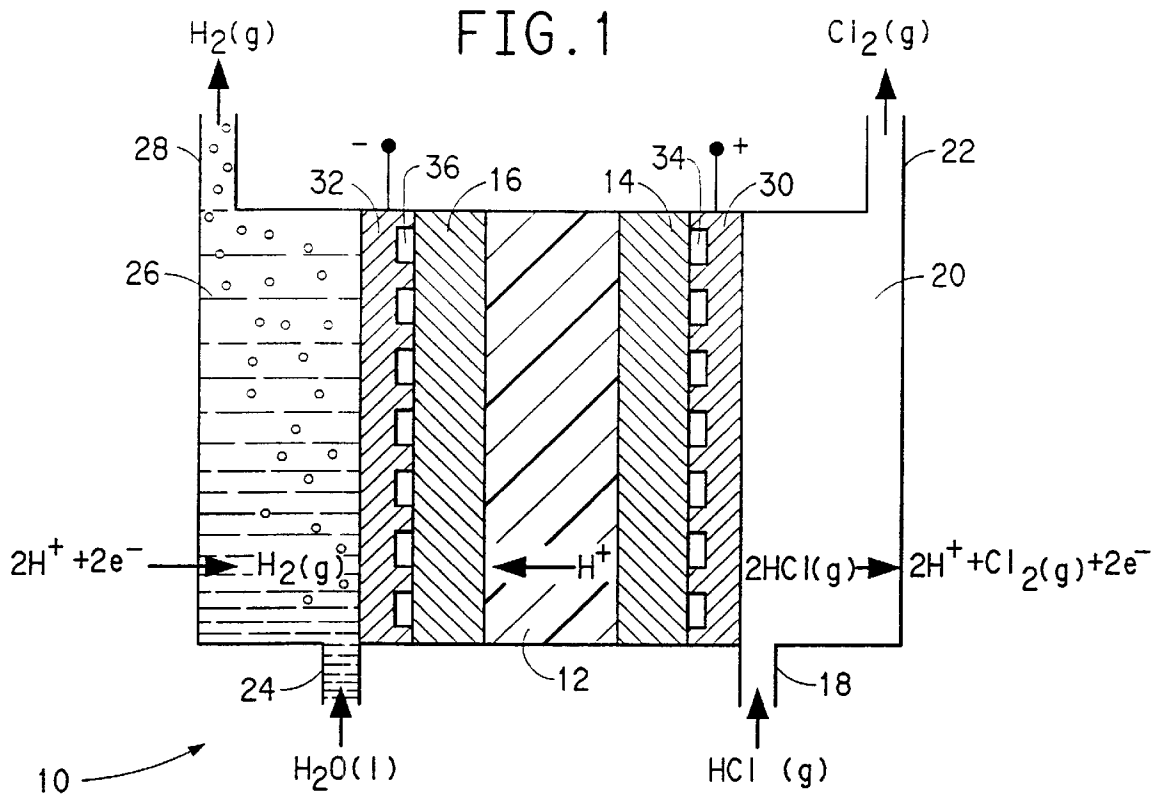

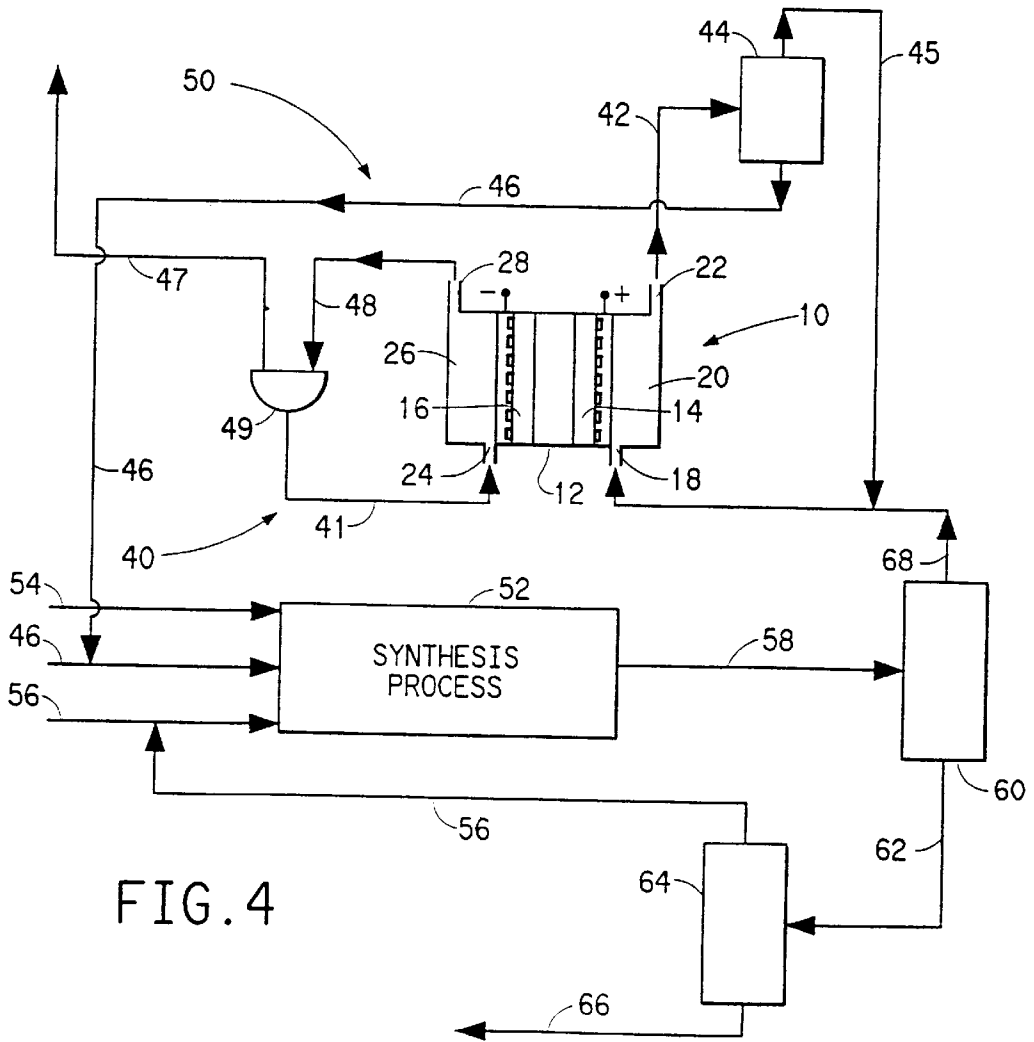
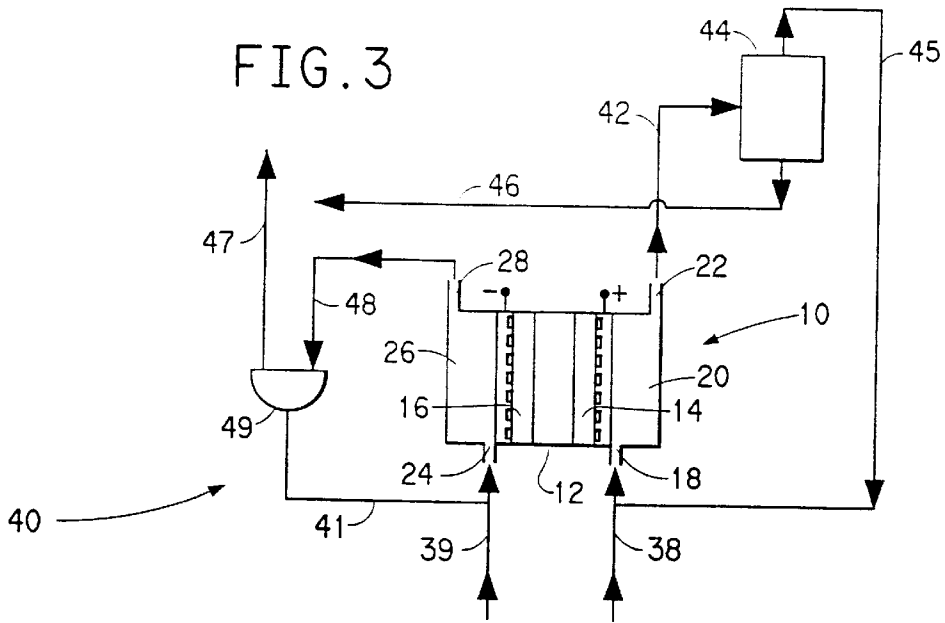

ANODE USEFUL FOR ELECTROCHEMICAL CONVERSION OF ANHYDROUS HYDROGEN HALIDE TO HALOGEN GAS

Matter enclosed in heavy brackets [] appears in the original patent but forms no part of this reissue specification; matter printed in italics indicates the additions made by reissue.

This application is a continuation-in-part of application Ser. No. 08/156,196, filed Nov. 22, 1993, now U.S. Pat. No. 5,411,641.

BACKGROUND OF THE INVENTION

1. Field of the Invention

The present invention relates to an anode useful in an electrochemical cell used for the direct production of essentially dry halogen gas from essentially anhydrous halogen halide, or for a process for such direct production of essentially dry halogen gas. This cell or process may be used to produce halogen gas such as chlorine, bromine, fluorine and iodine from a respective anhydrous hydrogen halide, such as hydrogen chloride, hydrogen bromide, hydrogen fluoride and hydrogen iodide. In particular, the anode of the present invention comprises the oxides of the elements tin, germanium and lead and mixtures comprising at least one of the respective oxides of such elements.

2. Description of the Related Art

A number of commercial processes have been developed to convert HCl into usable chlorine gas. See e.g., F. R. Minz, "HCl-Electrolysis—Technology for Recycling Chlorine", Bayer AG, Conference on Electrochemical Processing, Innovation & Progress, Glasgow, Scotland, UK Apr. 21–23, 1993. The current commercial electrochemical process is known as the Uhde process. In the Uhde process, aqueous HCl solution of approximately 22% is fed at 65° to 80° C. to both compartments of an electrochemical cell, where exposure to a direct current in the cell results in an electrochemical reaction and a decrease in HCl concentration to 17% with the production of chlorine gas and hydrogen gas. A polymeric separator divides the two compartments. The process requires recycling of dilute (17%) HCl solution produced during the electrolysis step and regenerating an HCl solution of 22% for feed to the electrochemical cell. The overall reaction of the Uhde process is expressed by the equation:

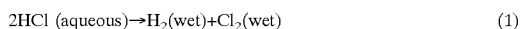

As is apparent from equation (1), the chlorine gas produced by the Uhde process is wet, usually containing about 1% to 2% water. This wet chlorine gas must then be further processed to produce a dry, usable gas. If the concentration of HCl in the water becomes too low, it is possible for oxygen to be generated from the water present in the Uhde process. This possible side reaction of the Uhde process due to the presence of water is expressed by the equation:



Further, the presence of water in the Uhde system limits the current densities at which the cells can perform to less than 500 amps./ft.², because of this side reaction. The result is reduced electrical efficiency and corrosion of the cell components due to the oxygen generated.

Another electrochemical process for processing aqueous HCl has been described in U.S. Pat. No. 4,311,568 to Balko.

Balko employs an electrolytic cell having a solid polymer electrolyte membrane. Hydrogen chloride, in the form of hydrogen ions and chloride ions in aqueous solution, is introduced into an electrolytic cell. The solid polymer electrolyte membrane is bonded to the anode to permit transport from the anode surface into the membrane. In Balko, controlling and minimizing the oxygen evolution side reaction is an important consideration. Evolution of oxygen decreases cell efficiency and leads to rapid corrosion of components of the cell. The design and configuration of the anode pore size and electrode thickness employed by Balko maximizes transport of the chloride ions. This results in effective chlorine evolution while minimizing the evolution of oxygen, since oxygen evolution tends to increase under conditions of chloride ion depletion near the anode surface. In Balko, although oxygen evolution may be minimized, it is not eliminated. As can be seen from FIGS. 3 to 5 of Balko, as the overall current density is increased, the rate of oxygen evolution increases, as evidenced by the increase in the concentration of oxygen found in the chlorine produced. Balko can run at higher current densities, but is limited by the deleterious effects of oxygen evolution. If the Balko cell were to be run at high current densities, the anode would be destroyed.

In general, the rate of an electrochemical process is characterized by its current density. In many instances, a number of electrochemical reactions may occur simultaneously. When this is true, the electrical driving force for electrochemical reactions is such that it results in an appreciable current density for more than one electrochemical reaction. For these situations, the reported or measured current density is a result of the current from more than one electrochemical reaction. This is the case for the electrochemical oxidation of aqueous hydrogen chloride. The oxidation of the chloride ions is the primary reaction. However, the water present in the aqueous hydrogen chloride is oxidized to evolve oxygen as expressed in equation (2). This is not a desirable reaction. The current efficiency allows one to describe quantitatively the relative contribution of the current from multiple sources. For example, if at the anode or cathode multiple reactions occur, then the current efficiency can be expressed as:

$$\eta_j = \frac{i_j}{\sum_{j=1}^{\text{NR}} i_j} \quad (3)$$

where η_j is the current efficiency of reaction j , and where there are NR number of reactions occurring.

For the example of an aqueous solution of HCl and an anode, the general expression above is:

$$\eta_{\text{Cl}_2} = \frac{i_{\text{Cl}_2}}{i_{\text{Cl}_2} + i_{\text{O}_2}} \quad (4)$$

$$\eta_{\text{Cl}_2} + \eta_{\text{O}_2} = 1.0 \quad (5)$$

In the specific case of hydrogen chloride in an aqueous solution, oxidation of chloride is the primary reaction, and oxygen evolution is the secondary reaction. In this case, the current density is the sum of the two anodic reactions. Since η_{Cl_2} is not zero, the current efficiency for chloride oxidation is less than unity, as expressed in equations (6) and (7)

below. Whenever one is concerned with the oxidation of chloride from an aqueous solution, then the current efficiency for oxygen evolution is not zero and has a deleterious effect upon the yield and production of chlorine.

$$\eta_{O_2} \neq 0 \quad (6)$$

$$\eta_{Cl_2} = 1.0 - \eta_{O_2} \cdots i_{Cl_2} = \eta_{Cl_2} \times i_{reported} \quad (7)$$

Furthermore, electrolytic processing of aqueous HCl can be mass-transfer limited. Mass-transfer of species is very much influenced by the concentration of the species as well as the rate of diffusion. The diffusion coefficient and the concentration of species to be transported are important factors which affect the rate of mass transport. In an aqueous solution, such as that used in Balko, the diffusion coefficient of a species is $\sim 10^{-5}$ cm.²/sec. In a gas, the diffusion coefficient is dramatically higher, with values $\sim 10^{-2}$ cm.²/sec. In normal industrial practice for electrolyzing aqueous hydrogen chloride, the practical concentration of hydrogen chloride or chloride ion is $\sim 17\%$ to 22% , whereas the concentration of hydrogen chloride is 100% in a gas of anhydrous hydrogen chloride. Above 22% , conductance drops, and the power penalty begins to climb. Below 17% , oxygen can be evolved from water, per the side reaction of equation (2), corroding the cell components, reducing the electrical efficiency, and contaminating the chlorine.

Electrochemical cells for converting aqueous HCl to chlorine gas by passage of direct electrical current through the solution are also known. Electrochemical cells for processing aqueous HCl, as exemplified by U.S. Pat. No. 4,210,501 to Dempsey et al., have typically used one or more reduced oxides of platinum group metals, such as ruthenium, iridium or platinum, or one or more reduced oxides of a valve metal, such as titanium, tantalum, niobium, zirconium, hafnium, vanadium or tungsten to stabilize the electrodes against oxygen, chlorine and generally harsh electrolysis conditions. U.S. Pat. No. 4,959,132 to Fedkiw discloses a process for producing an electrochemically active film proximate a solid polymer electrolyte membrane which may be used in electrochemical reactions, e.g., chlor-alkali processes. Fedkiw's process involves exposing a metal ion-loaded polymer membrane to a chemical reductant which reduces the ions to metal (0) state and produces an electrochemically active film. Tin sulfate, SnSO₄, is disclosed as the chemical reductant in the deposition of platinum as the electrochemically active film. Fedkiw also discloses the production of an electrocatalytic single metal film of lead, the production of films of alloys, which include tin/platinum, and the production of films of mixed metal composition, including lead/platinum, lead/palladium and lead/silver. However, Fedkiw does not recognize that the oxides of tin, germanium and lead and various mixtures comprising at least one of these oxides have applicability to the electrochemical processing of anhydrous hydrogen halides, with resulting high current densities.

SUMMARY OF THE INVENTION

Applicants have discovered that essentially anhydrous hydrogen chloride may be advantageously processed in an electrochemical cell which includes an anode comprising an electrochemically active material selected from the group [comprising] consisting of the oxides of the elements tin, germanium and lead and mixtures comprising at least one of the respective oxides of such elements.

With such an anode, the electrochemical cell can be run at higher current densities than those that can be achieved in

electrochemical cells of the prior art. Higher current densities translate into higher chlorine production per unit area of electrode. Thus, the present invention requires lower investment costs than the electrochemical conversions of hydrogen halide of the prior art.

To achieve the foregoing solutions, and in accordance with the purposes of the invention as embodied and broadly described herein, there is provided an anode used in a process for the direct production of essentially dry halogen gas from essentially anhydrous halogen halide or in a cell for performing this process. The cell also comprises a cation-transporting membrane and a cathode disposed in contact with one side of the membrane. The anode is disposed in contact with the other side of the membrane. The anode comprises an electrochemically active material selected from the group [comprising] consisting of the oxides of the elements tin, germanium and lead and mixtures comprising at least one of the respective oxides of such elements.

BRIEF DESCRIPTION OF THE DRAWINGS

FIG. 1 is a schematic diagram of an electrochemical cell for producing halogen gas from anhydrous hydrogen halide according to a first embodiment of the present invention, which has a hydrogen-producing cathode.

FIG. 2 is a schematic view of an electrochemical cell for producing halogen gas from anhydrous hydrogen halide according to a second embodiment of the present invention, which has a water-producing cathode.

FIG. 3 is a schematic diagram of a system which separates a portion of unreacted hydrogen chloride from the essentially dry chlorine gas and recycles it back to the electrochemical cell of FIG. 1.

FIG. 4 is a schematic diagram of a modification to the system of FIG. 3 which includes a synthesis process which produces anhydrous hydrogen chloride as a by-product and where the essentially dry chlorine gas is recycled to the synthesis process, and the unreacted hydrogen chloride is recycled back to the electrochemical cell of FIG. 1.

DESCRIPTION OF THE PREFERRED EMBODIMENTS

Reference will now be made in detail to the present preferred embodiments of the invention as illustrated in the accompanying drawings.

In accordance with the first embodiment of the present invention, there is provided an electrochemical cell for the direct production of essentially dry halogen gas from essentially anhydrous hydrogen halide. Such a cell is shown generally at 10 in FIG. 1. This cell will be described with respect to a preferred embodiment of the present invention, which directly produces essentially dry chlorine gas from anhydrous hydrogen chloride. However, this cell may alternatively be used to produce other halogen gases, such as bromine, fluorine and iodine from a respective anhydrous hydrogen halide, such as hydrogen bromide, hydrogen fluoride and hydrogen iodide. The term "direct" as used herein means that the electrochemical cell obviates the need to remove water from the chlorine produced or the need to convert essentially anhydrous hydrogen chloride to aqueous hydrogen chloride before electrochemical treatment. In this first embodiment, chlorine gas, as well as hydrogen, is produced by cell 10.

Cell 10 comprises a cation-transporting membrane 12 as shown in FIG. 1. More specifically, membrane 12 may be a proton-conducting membrane. Membrane 12 can be a com-

mercial cationic membrane made of a fluoro or perfluoropolymer, preferably a copolymer of two or more fluoro or perfluoromonomers, at least one of which has pendant sulfonic acid groups. The presence of carboxylic groups is not desirable, because those groups tend to decrease the conductivity of the membrane when they are protonated. Various suitable resin materials are available commercially or can be made according to patent literature. They include fluorinated polymers with side chains of the type $-\text{CF}_2\text{CFR}\text{SO}_3\text{H}$ and $-\text{OCF}_2\text{CF}_2\text{CF}_2\text{SO}_3\text{H}$, where R is an F, Cl, CF_2Cl , or a C_1 to C_{10} perfluoroalkyl radical. The membrane resin may be, for example, a copolymer of tetrafluoroethylene with $\text{CF}_2=\text{CFOCF}_2\text{CF}(\text{CF}_3)\text{OCF}_2\text{CF}_2\text{SO}_3\text{H}$. Sometimes these resins may be in the form that has pendant $-\text{SO}_2\text{F}$ groups, rather than $-\text{SO}_3\text{H}$ groups. The sulfonyl fluoride groups can be hydrolyzed with potassium hydroxide to $-\text{SO}_3\text{K}$ groups, which then are exchanged with an acid to $-\text{SO}_3\text{H}$ groups. Suitable cationic membranes, which are made of hydrated, copolymers of polytetrafluoroethylene and polysulfonyl fluoride vinyl ether-containing pendant sulfonic acid groups, are offered for sale by E. I. du Pont de Nemours and Company of Wilmington, Del. (hereinafter referred to as "DuPont") under the trademark "NAFION" (hereinafter referred to as NAFION®). In particular, NAFION® membranes containing pendant sulfonic acid groups include NAFION® 117, NAFION® 324 and NAFION® 417. The first type of NAFION® is unsupported and has an equivalent weight of 1100 g., equivalent weight being defined as the amount of resin required to neutralize one liter of a 1M sodium hydroxide solution. The other two types of NAFION® are both supported on a fluorocarbon fabric, the equivalent weight of NAFION® 417 also being 1100 g. NAFION® 324 has a two-layer structure, a 125 μm -thick membrane having an equivalent weight of 1100 g., and a 25 μm -thick membrane having an equivalent weight of 1500 g. A NAFION® 117F grade membrane, which is a precursor membrane having pendant $-\text{SO}_2\text{F}$ groups that can be converted to sulfonic acid groups, is also commercially available from DuPont.

Although the present invention describes the use of a solid polymer electrolyte membrane, it is well within the scope of the invention to use other cation-transporting membranes which are not polymeric. For example, proton-conducting ceramics such as beta-alumina may be used. Beta-alumina is a class of nonstoichiometric crystalline compounds having the general structure $\text{Na}_2\text{O}_x\text{Al}_2\text{O}_3$, in which x ranges from 5 (β' -alumina) to 11 (β -alumina). This material and a number of solid electrolytes which are useful for the invention are described in the Fuel Cell Handbook, A. J. Appleby and F. R. Foulkes, Van Nostrand Reinhold, N.Y., 1989, pages 308-312. Additional useful solid state proton conductors, especially the cerates of strontium and barium, such as strontium ytterbiate cerate ($\text{SrCe}_{0.95}\text{Yb}_{0.05}\text{O}_{3-\alpha}$) and barium neodymate cerate ($\text{BaCe}_{0.9}\text{Nd}_{0.01}\text{O}_{3-\alpha}$) are described in final report, DOE/MC/24218-2957, Jewulski, Osif and Remick, prepared for the U.S. Department of Energy, Office of Fossil Energy, Morgantown Energy Technology Center by Institute of Gas Technology, Chicago, Ill. December, 1990.

Electrochemical cell 10 also comprises a pair of electrodes, specifically, an anode 14 and a cathode 16. As shown in FIG. 1, cathode 16 is disposed in contact with one side of the membrane, and anode 14 is disposed in contact with the other side of the membrane. Anode 14 has an anode inlet 18 which leads to an anode chamber 20, which in turn leads to an anode outlet 22. Cathode 16 has a cathode inlet

24 which leads to a cathode chamber 26, which in turn leads to a cathode outlet 28. As known to one skilled in the art, if electrodes are placed on opposite faces of a membrane, cationic charges (protons in the HCl reaction being described) are transported through the membrane from anode to cathode, while each electrode carries out a half-cell reaction. In the present invention, molecules of anhydrous hydrogen chloride are transported to the surface of the anode through inlet 18. The molecules of the anhydrous hydrogen chloride are oxidized to produce essentially dry chlorine gas and protons. The essentially dry chlorine gas exits through anode outlet 22 as shown in FIG. 1. The protons, designated as H^+ in FIG. 1, are transported through the membrane and reduced at the cathode. This is explained in more detail below.

The anode of the present invention comprises an electrochemically active material. Preferably, the electrochemically active material used for the anode in the present invention is selected from the group [comprising] consisting of the oxides of the elements tin, germanium and lead and mixtures comprising at least one of the respective oxides of these elements. The phrase "mixtures comprising at least one of the respective oxides of these elements" means at least one of any of these oxides mixed with at least one of any other of these oxides and/or any other constituent.

The cathode used for the present invention also comprises an electrochemically active material. The electrochemically active material used for the cathode may comprise any type of catalytic or metallic material or metallic oxide, as long as the material can support charge transfer. Preferably, the electrochemically active material used for the cathode may comprise any one of the elements platinum, ruthenium, osmium, rhenium, rhodium, iridium, palladium, gold, titanium or zirconium, the oxides of these elements, the alloys of these elements and mixtures comprising any of these elements, oxides and alloys. The phrase "mixtures comprising any of these elements, oxides and alloys" means at least one of these elements, oxides and alloys mixed with at least one of any other of these elements, oxides and alloys and/or any other constituent. Other electrochemically active materials suitable for use with the present invention may include, but are not limited to, transition metal macrocycles in monomeric and polymeric forms and transition metal oxides, including perovskites and pyrochlores, including mixtures comprising such oxides, perovskites and pyrochlores.

The anode and the cathode may comprise porous, gas-diffusion electrodes. Such electrodes provide the advantage of high specific surface area, as known to one skilled in the art. The electrochemically active material used for either the anode or the cathode, or both, is disposed adjacent, meaning at, on or under, the surface of the cation-transporting membrane. A thin film of the electrochemically active material used for either the anode or the cathode, or both, may be applied directly to the membrane. Alternatively, the electrochemically active material used for either the anode or the cathode, or both, may be hot-pressed to the membrane, as shown in A. J. Appleby and E. B. Yeager, Energy, Vol. 11, 137 (1986). Alternatively, the electrochemically active material used for either the anode or the cathode, or both, may be deposited into the membrane, as shown in U.S. Pat. No. 5 4,959,132 to Fedkiw.

The electrochemically active material used for either the anode or the cathode, or both, may comprise a catalyst material. In a hot-pressed electrode, the electrochemically active material may comprise a catalyst material on a support material. The support material may comprise par-

titles of carbon and particles of polytetrafluoroethylene, which is sold under the trademark "TEFLON" (hereinafter referred to as TEFLON®), commercially available from DuPont. The electrochemically active material may be bonded by virtue of the TEFLON® to a support structure of carbon paper or graphite cloth and hot-pressed to the cation-transporting membrane. The hydrophobic nature of TEFLON® does not allow a film of water to form at the anode. A water barrier in the electrode would hamper the diffusion of HCl to the reaction sites. The electrodes are preferably hot-pressed into the membrane in order to have good contact between the catalyst material and the membrane.

The loadings of electrochemically active material may vary based on the method of application to the membrane. Hot-pressed, gas-diffusion electrodes typically have loadings of 0.10 to 0.50 mg./cm.². Lower loadings are possible with other available methods of deposition, such as distributing them as thin films from inks onto the membranes, as described in Wilson and Gottesfeld, "High Performance Catalyzed Membranes of Ultra-low Pt Loadings for Polymer Electrolyte Fuel Cells", Los Alamos National Laboratory, J. Electrochem. Soc., Vol. 139, No. 2 L28-30, 1992, where the inks contain solubilized NAFION® ionomer to enhance the catalyst material/ionomer surface contact and to act as a binder to the NAFION® membrane sheet. With such a system, loadings as low as 0.017 mg. of catalyst material per cm.² have been achieved.

A current collector **30**, **32**, respectively, is disposed in electrical contact with the anode and the cathode, respectively, for collecting charge. Another function of the current collectors is to direct anhydrous hydrogen chloride to the anode and to direct any water added to the cathode at inlet **24** to keep the membrane hydrated, as will be discussed below. More specifically, the current collectors are machined with flow channels **34**, **36** as shown in FIG. 1 for directing the anhydrous HCl to the anode and the water added to the cathode. It is within the scope of the present invention that the current collectors and the flow channels may have a variety of configurations. Also, the current collectors may be made in any manner known to one skilled in the art. For example, the current collectors may be machined from graphite blocks impregnated with epoxy to keep the hydrogen chloride and chlorine from diffusing through the block. This impregnation also prevents oxygen and water from leaking through the blocks. The current collectors may also be made of a porous carbon in the form of a foam, cloth or mat. The current collectors may also include thermocouples or thermistors (not shown) to monitor and control the temperature of the cell.

The electrochemical cell of the first embodiment also comprises a structural support for holding the cell together. Preferably, the support comprises a pair of backing plates which are torqued to high pressures to reduce the contact resistances between the current collectors and the electrodes. The plates may be aluminum, but are preferably a corrosion-resistant metal alloy. The plates include heating elements (not shown) which are used to control the temperature of the cell. A non-conducting element, such as TEFLON® or other insulator, is disposed between the collectors and the backing plates.

The electrochemical cell of the first embodiment also includes a voltage source (not shown) for supplying a voltage to the cell. The voltage source is attached to the cell through current collectors **30** and **32** as indicated by the + and - terminals, respectively, as shown in FIG. 1.

When more than one anode-cathode pair is used, such as in manufacturing, a bipolar arrangement is preferred. In the

simple cell shown in FIG. 1, a single anode and cathode are shown. The current flows from the external voltage source to the cathode and returns to the external source through the lead connected to the anode. With the stacking of numerous anode-cathode pairs, it is not most convenient to supply the current in this fashion. Hence, for a bipolar arrangement, the current flows through the cell stack. This is accomplished by having the current collector for the anode and the cathode machined from one piece of material. Thus, on one face of the current collector, the gas (HCl) for the anode flows in machined channels past the anode. On the other face of the same current collector, channels are machined, and the current is used in the cathodic reaction, which produces hydrogen in this invention. The current flows through the repeating units of a cell stack without the necessity of removing and supplying current to each individual cell. The material selected for the current collector must be resistant to the oxidizing conditions on the anode side and the reducing conditions on the cathode side. Of course, the material must be electronically conductive. In a bipolar configuration, insulators are not interspersed in the stack as described above. Rather, there are backing plates at the ends of the stack, and these may be insulated from the adjacent current collectors.

Further in accordance with the first embodiment of the present invention, there is provided a process for the direct production of essentially dry halogen gas from essentially anhydrous hydrogen halide. The anhydrous hydrogen halide may comprise hydrogen chloride, hydrogen bromide, hydrogen fluoride or hydrogen iodide. It should be noted that the production of bromine and iodine gas can be accomplished when the electrochemical cell is run at elevated temperatures (i.e., about 60° C. and above for bromine and about 190° C. and above for iodine). In the case of iodine, a membrane made of a material other than NAFION® should be used.

The operation of the electrochemical cell of the first embodiment will now be described as it relates to a preferred embodiment of the process of the present invention, where the anhydrous hydrogen halide is hydrogen chloride. In operation, molecules of essentially anhydrous hydrogen chloride gas are transported to the surface of the anode through anode inlet **18** and through gas channels **34**. Water (H₂O (l)) as shown in FIG. 1 is delivered to the cathode through cathode inlet **24** and through channels **36** formed in cathode current collector **32** to hydrate the membrane and thereby increase the efficiency of proton transport through the membrane. Molecules of the anhydrous hydrogen chloride (HCl(g)) as shown in FIG. 1 are oxidized at the anode under the potential created by the voltage source to produce essentially dry chlorine gas (Cl₂(g)) at the anode, and protons (H⁺) as shown in FIG. 1. This reaction is given by the equation:

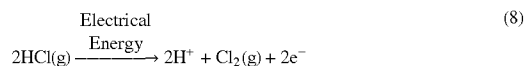

The chlorine gas (Cl₂(g)) exits through anode outlet **22** as shown in FIG. 1. The protons (H⁺) are transported through the membrane, which acts as an electrolyte. The transported protons are reduced at the cathode. This reaction is given by the equation:



The hydrogen which is evolved at the interface between the electrode and the membrane exits via cathode outlet **28** as shown in FIG. 1. The hydrogen bubbles through the water and is not affected by the TEFLON® in the electrode.

FIG. 2 illustrates a second embodiment of the present invention. Wherever possible, elements corresponding to the elements of the embodiment of FIG. 1 will be shown with the same reference numeral as in FIG. 1, but will be designated with a prime (').

In accordance with the second embodiment of the present invention, there is provided an electrochemical cell for the direct production of essentially dry halogen gas from anhydrous hydrogen halide. This cell will be described with respect to a preferred embodiment of the present invention, which directly produces essentially dry chlorine gas from anhydrous hydrogen chloride. However, this cell may alternatively be used to produce other halogen gases, such as bromine, fluorine and iodine from a respective anhydrous hydrogen halide, such as hydrogen bromide, hydrogen fluoride and hydrogen iodide. Such a cell is shown generally at **10'** in FIG. 2. In this second embodiment, water, as well as chlorine gas, is produced by this cell.

Cell **10'** comprises a cation-transporting membrane **12'** as shown in FIG. 2. Membrane **12'** may be a proton-conducting membrane. Preferably, membrane **12'** comprises a solid polymer membrane, and more preferably the polymer comprises NAFION® as described above with respect to the first embodiment. Alternatively, the membrane may comprise other materials as described above with respect to the first embodiment.

Electrochemical cell **10'** also comprises a pair of electrodes. Specifically, a cathode **16'** is disposed in contact one side of the membrane, and an anode **14'** is disposed in contact with the other side of the membrane as shown in FIG. 2. Anode **14'** has an inlet **18'** which leads to an anode chamber **20'**, which in turn leads to an outlet **22'**. Cathode **16'** has an inlet **24'** which leads to a cathode chamber **26'**, which in turn leads to an outlet **28'**. Anode **14'** and cathode **16'** function and are constructed and made of the same materials and as described above with respect to the first embodiment. As in the first embodiment, the anode and the cathode may comprise porous, gas-diffusion electrodes.

The electrochemical cell of the second embodiment of the present invention also comprises a current collector **30'**, **32'** disposed in electrical contact with the anode and the cathode, respectively, for collecting charge. The current collectors are machined with flow channels **34'**, **36'** as shown in FIG. 2 for directing the anhydrous HCl to the anode and the oxygen (O₂) to the cathode. The current collectors are constructed and function as described above with respect to the first embodiment. In addition to collecting charge, another function of the current collectors in this second embodiment is to direct anhydrous hydrogen chloride across the anode. The cathode current collector directs the oxygen-containing gas, which may contain water vapor as the result of humidification, to the cathode. Water vapor may be needed to keep the membrane hydrated. However, water vapor may not be necessary in this embodiment because of the water produced by the electrochemical reaction of the oxygen (O₂) added as discussed below.

The electrochemical cell of the second embodiment also comprises a structural support for holding the cell together.

Preferably, the support comprises a pair of backing plates (not shown) which are constructed and which function as described above with respect to the first embodiment.

The electrochemical cell of the second embodiment also includes a voltage source (not shown) for supplying a voltage to the cell. The voltage source is attached to the cell through current collectors **30'** and **32'** as indicated by the + and - terminals, respectively, as shown in FIG. 2.

Further in accordance with the second embodiment of the present invention, there is provided a process for the direct production of essentially dry halogen gas from essentially anhydrous hydrogen halide. As in the first embodiment, the anhydrous hydrogen halide may comprise hydrogen chloride, hydrogen bromide, hydrogen fluoride or hydrogen iodide. Also as in the first embodiment, the production of bromine gas and iodine gas can be accomplished when the electrochemical cell is run at elevated temperatures (i.e., about 60° C. and above for bromine and about 190° C. and above for iodine). In the case of iodine, a membrane made of a material other than NAFION® should be used.

The operation of the electrochemical cell of the second embodiment will now be described as it relates to a preferred embodiment of the process of the present invention, where the anhydrous hydrogen halide is hydrogen chloride. In operation, molecules of essentially anhydrous hydrogen chloride are transported to the anode through anode inlet **18'** and through gas channels **34'**. An oxygen-containing gas, such as oxygen (O₂(g) as shown in FIG. 2), air or oxygen-enriched air (i.e., greater than 21 mol % oxygen in nitrogen) is introduced through cathode inlet **24'** as shown in FIG. 2 and through channels **36'** formed in the cathode current collector. Although air is cheaper to use, cell performance is enhanced when enriched air or oxygen is used. This cathode feed gas may be humidified to aid in the control of moisture in the membrane. Molecules of the hydrogen chloride (HCl (g)) as shown in FIG. 2) are oxidized under the potential created by the voltage source to produce essentially dry chlorine gas at the anode, and protons (H+) as shown in FIG. 2, as expressed in equation (8) above. The chlorine gas (Cl₂) exits through anode outlet **22'** as shown in FIG. 2. The protons (H⁺) are transported through the membrane, which acts as an electrolyte. Oxygen and the transported protons are reduced at the cathode to water, which is expressed by the equation:

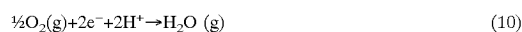

The water formed (H₂O (g) in equation (10)) exits via cathode outlet **28'** as shown in FIG. 2, along with any nitrogen and unreacted oxygen. The water also helps to maintain hydration of the membrane, as will be further explained below.

In this second embodiment, the cathode reaction is the formation of water. This cathode reaction has the advantage of more favorable thermodynamics relative to H₂ production at the cathode as in the first embodiment. This is because the overall reaction in this embodiment, which is expressed by the following equation:

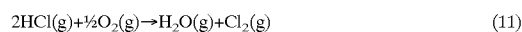

involves a smaller free-energy change than the free-energy change for the overall reaction in the first embodiment, which is expressed by the following equation:

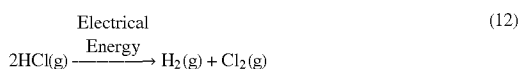

Thus, the amount of voltage or energy required as input to the cell is reduced in this second embodiment.

The membrane of both the first and the second embodiments must be hydrated in order to have efficient proton transport. Thus, the process of either embodiment of the present invention includes the step of keeping the cathode side of the membrane moist to increase the efficiency of proton transport through the membrane. In the first embodiment, which has a hydrogen-producing cathode, the hydration of the membrane is obtained by keeping liquid water in contact with the cathode. The liquid water passes through the gas-diffusion electrode and contacts the membrane. In the second embodiment, which has a water-producing cathode, the membrane hydration is accomplished by the production of water as expressed by equation (10) above and by the water introduced in a humidified oxygen-feed or air-feed stream. This keeps the conductivity of the membrane high.

In either of the first or second embodiments, the electrochemical cell can be operated over a wide range of temperatures. Room temperature operation is an advantage, due to the ease of use of the cell. However, operation at elevated temperatures provides the advantages of improved kinetics and increased electrolyte conductivity. It should be noted also that one is not restricted to operate the electrochemical cell of either the first or the second embodiment at atmospheric pressure. The cell could be run at differential pressure gradients, which change the transport characteristics of water or other components in the cell, including the membrane.

The electrochemical cell of either embodiment of the present invention can be operated at higher temperatures at a given pressure than electrochemical cells operated with aqueous hydrogen chloride of the prior art. This affects the kinetics of the reactions and the conductivity of the NAFION®. Higher temperatures result in lower cell voltages. However, limits on temperature occur because of the properties of the materials used for elements of the cell. For example, the properties of a NAFION® membrane change when the cell is operated above 120° C. The properties of a polymer electrolyte membrane make it difficult to operate a cell at temperatures above 150° C. With a membrane made of other materials, such as a ceramic material like beta-alumina, it is possible to operate a cell at temperatures above 200° C.

In either the first or the second embodiment of the present invention, a portion of the anhydrous hydrogen chloride may be unreacted after contacting the cell and may exit the cell through the anode outlet along with the chlorine gas. This concept is illustrated with respect to FIG. 3, where a system for recycling unreacted anhydrous hydrogen chloride from essentially dry chlorine gas is shown generally at 40. It should be noted that the system of FIG. 3 could be used to recycle other unreacted anhydrous hydrogen halides from a respective essentially dry halogen gas, such as fluorine, bromine or iodine, chlorine gas being used only as a representative halogen gas. The system of FIG. 3 recycles the unreacted anhydrous hydrogen chloride back to cell 10 of the first embodiment, which includes membrane 12, anode 14, anode chamber 20, cathode 16 and cathode chamber 26 as described above. Cell 10 also includes current collectors 30, 32 having flow channels 34, 36 formed

therein. Cell 10 also includes a feed line 38 for feeding anhydrous hydrogen chloride and a feed line 39 for feeding water, as described above for the first embodiment. The unreacted portion of the anhydrous HCl is separated from the essentially dry chlorine gas by a separator 44 in a separation process which may involve distillation, adsorption, extraction, membrane separation or any number of known separation techniques. The separated, unreacted portion of anhydrous HCl in the essentially dry chlorine gas is recycled through a line 45 as shown in FIG. 3 back to anode inlet 18 of electrochemical cell 10 as shown in FIG. 3. The separated chlorine gas exits through a line 46. In the system of FIG. 3, hydrogen gas (H₂) exits cell 10 through cathode outlet 28 as described with respect to the first embodiment and through a line 48. Excess water may also exit through cathode outlet 28, where it is separated from hydrogen gas in a knock-out tank 49 and recycled to cathode inlet 24 through a line 41. The separated hydrogen gas exits through a line 47. It should be understood that the cell of the second embodiment of the present invention alternatively could be used in the system of FIG. 3, except that oxygen gas (O₂) would enter the cathode inlet from feed line 39, and water in the form of gas (H₂O(g)), along with any nitrogen and unreacted oxygen, would exit the cathode outlet.

A modification of the system as shown in FIG. 3 above involves recycling the essentially dry chlorine gas which has been separated from the unreacted anhydrous hydrogen chloride to a synthesis process where chlorine is a reactant and anhydrous hydrogen chloride is a by-product. This modification is illustrated in FIG. 4, where a system which recycles separated chlorine gas to a synthesis process is shown generally at 50. System 50 includes system 40 as described above, as well as a synthesis process 52 and other components associated therewith as described below. Essentially dry chlorine gas is recycled through a line 46 as described above to synthesis process 52. Other reactant inlet lines are shown at 54 and 56. For instance, in a hydrofluorination process, inlet line 54 could bring in hydrocarbon, and inlet line 56 could bring in hydrogen fluoride (HF). Fluorinated hydrocarbons, unreacted HF and anhydrous hydrogen chloride exit process 52 through a line 58 and are separated in a separator 60 by any known separation process. The anhydrous hydrogen chloride is fed to anode inlet 18 through a line 68 and is combined with a recycled stream in line 45 as shown in FIG. 4. Fluorinated hydrocarbons and unreacted HF exit separator 60 via a line 62 and flow to a further separator 64, which separates the fluorinated hydrocarbons from the unreacted HF. The fluorinated hydrocarbons exit separator 64 through a line 66. The unreacted HF is recycled back to synthesis process 52 through a line 67, which joins up with inlet line 56. This system could also be used for bringing in hydrochlorofluorocarbons or chlorofluorocarbons plus hydrogen and a hydrodechlorination catalyst to produce hydrogen chloride. It is, of course, within the scope of the present invention alternatively to use the cell of the second embodiment in the system of FIG. 4 with the differences to the system as noted above. #

The invention will be clarified by the following Examples, which are intended to be purely exemplary of the invention. In the Examples given below, experimental data are presented which show cell potential and current density for three different temperatures. These data were obtained by operating the cell and the process of the present invention for different modes of operation in each Example. The electrode/membrane assemblies used in the following Examples were obtained from Giner, Inc. of Waltham, Mass., as membrane and electrode assemblies (MEA's).

EXAMPLE 1

In this Example, a non-steady state electrochemical experiment (i.e., of a duration of five minutes for each potential setting) generating chlorine and hydrogen was performed in an electrochemical cell which was 1 cm. x 1 cm. in size. In this Example, tin oxide (SnO₂), approximately 0.1–0.2% by weight, extended with carbon, was used for the anode. Ruthenium oxide (RuO₂), approximately 0.1–0.2% by weight, extended with carbon, was used for the cathode. The anode and the cathode were both bonded to the membrane, which was made of NAFION® 117. The potential from the power source was stepped in 0.10 volt increments from 1.5 to 2.8 volts. At each 0.10 volt increment, the potential was maintained for five minutes. The current density at the specific cell potentials was recorded at three different temperatures, namely 25° C., 40° C. and 60° C., in order to assess the importance of this variable upon cell performance, and the data is given in Table 1 below.

TABLE 1

Cell Potential [volts]	Current Density [mAmp./cm. ²]		
	25° C.	40° C.	60° C.
1.5	65	100	110
1.6	121	172	154
1.7	179	262	264
1.8	257	352	379
1.9	324	462	500
2.0	429	579	628
2.1	500	627	707
2.2	586	759	779
2.3	671	786	864
2.4	729	855	879
2.5	779	875	942
2.6	821	903	957
2.7	850	924	—
2.8	871	937	—

EXAMPLE 2

In this Example, a steady-state electrochemical experiment (i.e., of a duration of two to five hours for each potential setting) generating chlorine and hydrogen was performed in an electrochemical cell which was 1 cm. x 1 cm. in size. As in Example 1 above, tin oxide (SnO₂) approximately 0.1–0.2% by weight, extended with carbon, was used for the anode. Ruthenium oxide (RuO₂), approximately 0.1–0.2% by weight, extended with carbon, was used for the cathode. The anode and the cathode were both bonded to the membrane, which was made of NAFION® 117. The potential from the power source was stepped in 0.10 volt increments from 1.5 to 2.8 volts. Normally steady-state operation was achieved within one hour, but typically each potential was held for two to five hours before stepping up to the next potential setting. The current collectors were machined from graphite, Type 900 SY, extruded and densified carbon, having a particle size of 0.06 inches and an ash content of 1000 ppm. as supplied by The Carbon/Graphite Group, Inc., of St. Mary's, Pa. The current density was recorded at three different temperatures, namely 25° C., 40° C. and 60° C., and the data is given in Table 2 below. The proton-exchange electrode/membrane assembly was operated for a total of 285 hours before dismantling.

TABLE 2

Cell Potential [volts]	Current Density [mAmp./cm. ²]		
	25° C.	40° C.	60° C.
1.5	28	28	62
1.6	55	83	138
1.7	131	166	248
1.8	197	248	359
1.9	269	338	455
2.0	345	424	538
2.1	403	507	635
2.2	476	566	724
2.3	559	669	793
2.4	628	731	—
2.5	697	779	—
2.6	766	766	—
2.7	766	779	—
2.8	766	855	—

The results of these Examples indicate electrochemical cell performance which can exceed that generally obtained in the prior art. In addition, these Examples show the stability and longevity of electrochemical cells which use anodes comprising tin oxide.

Additional advantages and modifications will readily occur to those skilled in the art. The invention, in its broader aspects, is therefore not limited to the specific details, representative apparatus and illustrative Examples shown and described. Accordingly, departures may be made from such details without departing from the spirit or scope of the general inventive concept as defined by the appended claims and their equivalents.

What is claimed is:

1. A process for the direct production of essentially dry halogen gas from essentially anhydrous hydrogen halide, wherein molecules of essentially anhydrous hydrogen halide are fed to an inlet of an electrochemical cell comprising a cation-transporting membrane, a cathode disposed in contact with one side of the membrane and an anode disposed in contact with the other side of the membrane and are transported to the anode of the cell, the anode and the cathode each comprising an electrochemically active material, wherein the electrochemically active material of the anode is selected from the group consisting of the oxides of the elements tin, germanium and lead and mixtures comprising at least one of the respective oxides of said elements, and further wherein the molecules of the essentially anhydrous hydrogen halide are oxidized at the anode to produce essentially dry halogen gas and protons, the protons are transported through the membrane and the transported protons are reduced at the cathode.

2. The process of claim 1, wherein the hydrogen halide is selected from the group consisting of: hydrogen chloride, hydrogen bromide, hydrogen fluoride and hydrogen iodide.

3. The process of claim 1, wherein the transported protons are reduced to form hydrogen gas.

4. The process of claim 1, further including the step of keeping the cathode side of the membrane moist to increase the efficiency of proton transport through the membrane.

5. An electrochemical cell for the direct production of essentially dry halogen gas from essentially anhydrous hydrogen halide, comprising:

(a) means for oxidizing molecules of essentially anhydrous hydrogen halide to produce essentially dry halogen gas and protons, the oxidizing means comprising an electrochemically active material, wherein the elec-

15

trochemically active material is selected from the group consisting of the oxides of the elements tin, germanium and lead and mixtures comprising at least one of the respective oxides of said elements;

(b) cation-transporting means for transporting the protons therethrough, wherein the oxidizing means is disposed in contact with one side of the cation-transporting means; and

(c) means for reducing the transported protons, wherein the reducing means is disposed in contact with the other side of the cation-transporting means.

6. The electrochemical cell of claim 5, wherein the electrochemically active material comprises tin oxide.

7. The electrochemical cell of claim 5, wherein the oxidizing means is an anode and the reducing means is a cathode, and further wherein the anode and the cathode are gas-diffusion electrodes.

8. The electrochemical cell of claim 7, wherein the cathode also comprises an electrochemically active material.

9. The electrochemical cell of claim 8, wherein the electrochemically active material of the cathode comprises one of the following elements: platinum, ruthenium, osmium, rhenium, rhodium, iridium, palladium, gold, titanium and zirconium, the oxides of said elements, the alloys of said elements and mixtures comprising any of said elements, oxides and alloys.

10. The electrochemical cell of claim 7, wherein the anode comprises tin oxide extended with carbon.

11. The electrochemical cell of claim 10, wherein the cathode comprises ruthenium oxide extended with carbon.

12. A process for the direct production of essentially dry halogen gas from essentially anhydrous hydrogen halide, wherein:

(a) molecules of essentially anhydrous hydrogen halide are fed to an inlet of an electrochemical cell and are transported to an anode of the cell, the anode comprising an electrochemically active material, wherein the electrochemically active material is selected from the group consisting of the oxides of the elements tin, germanium and lead and mixtures comprising at least one of the respective oxides of said elements;

(b) the molecules of the essentially anhydrous hydrogen halide are oxidized at the anode to produce essentially dry halogen gas and protons;

(c) the protons are transported through a cation-transporting membrane of the electrochemical cell to a cathode, the membrane having an anode side and a cathode side;

(d) a gas containing oxygen is introduced at the cathode side of the membrane; and

(e) the transported protons are reduced at the cathode, and the protons and oxygen are reduced at the cathode to form water.

16

13. The process of claim 12, wherein the oxygen-containing gas comprises one of the following air, oxygen and oxygen-enriched air.

14. A process for recycling unreacted anhydrous hydrogen halide generated from the direct production of essentially dry halogen gas from essentially anhydrous hydrogen halide, wherein:

(a) molecules of essentially anhydrous hydrogen halide are fed to an inlet of an electrochemical cell and are transported to an anode of the cell, wherein the anode comprises an electrochemically active material selected from the group consisting of the oxides of the elements tin, germanium and lead and mixtures comprising at least one of the respective oxides of said elements;

(b) a portion of the essentially anhydrous hydrogen halide is oxidized at the anode to produce essentially dry halogen gas and protons;

(c) the protons are transported through a cation-transporting membrane of the electrochemical cell;

(d) the transported protons are reduced at a cathode of the electrochemical cell;

(e) another portion of the essentially anhydrous hydrogen halide is unreacted and is separated from the essentially dry halogen gas; and

(f) the unreacted, separated portion of the anhydrous hydrogen halide exits the cell through an outlet thereof and is recycled to the inlet of the electrochemical cell.

15. The process of claim 14, wherein the essentially dry halogen gas is recycled to a synthesis process which produces anhydrous hydrogen halide as a by-product.

16. A process for recycling essentially dry halogen gas to a synthesis process, wherein the essentially dry halogen gas is generated directly from essentially anhydrous hydrogen halide, wherein:

(a) molecules of essentially anhydrous hydrogen halide are fed to an inlet of an electrochemical cell and are transported to an anode of the cell, wherein the anode comprises an electrochemically active material selected from the group consisting of the oxides of the elements tin, germanium and lead and mixtures comprising at least one of the respective oxides of said elements;

(b) a portion of the essentially anhydrous hydrogen halide is oxidized at the anode to produce essentially dry halogen gas and protons;

(c) the protons are transported through a cation-transporting membrane of the electrochemical cell;

(d) the transported protons are reduced at a cathode of the electrochemical cell; and

(e) the essentially dry halogen gas is recycled to a synthesis process which produces anhydrous hydrogen halide as a by-product.

* * * * *