

I. CRESSMAN.
Soldering Iron Heater.

No. 41,200.

Patented Jan. 12, 1864.

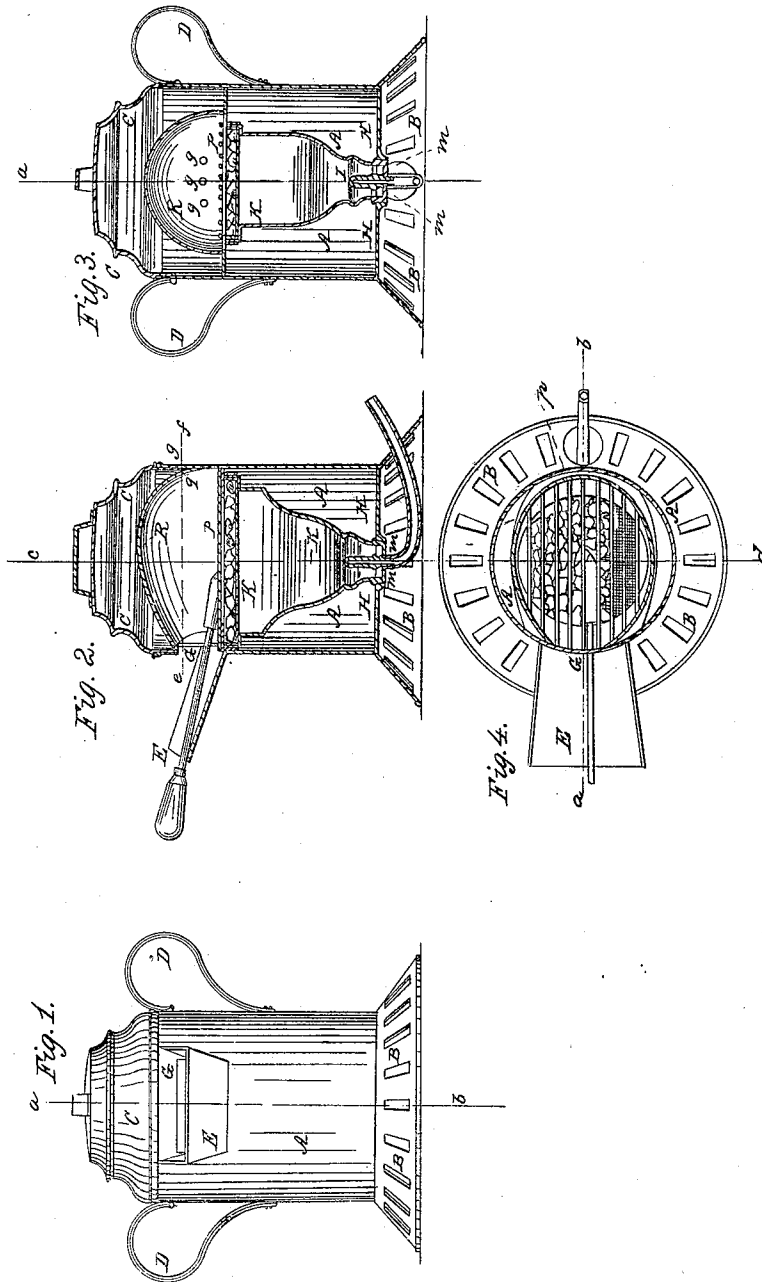

Witnesses:
J. J. Guile
J. L. Coombs.

Inventor:
I. Cressman
by *A. B. Holt*
his atty.

UNITED STATES PATENT OFFICE.

ISAAC CRESSMAN, OF PHILADELPHIA, PENNSYLVANIA, ASSIGNOR TO HIMSELF AND DANIEL BOHLER.

IMPROVEMENT IN STOVES FOR HEATING SOLDERING-IRONS.

Specification forming part of Letters Patent No. 41,200, dated January 12, 1864.

To all whom it may concern:

Be it known that I, ISAAC CRESSMAN, of Philadelphia, in the county of Philadelphia and State of Pennsylvania, have invented certain new and useful Improvements in Soldering Pots or Furnaces; and I hereby declare that the following is a full, clear, and exact description of the same, reference being had to the accompanying drawings, in which—

Figure 1 is a front elevation of my improved soldering pot or furnace. Figs. 2 and 3 are sectional views of the same, according to the vertical planes indicated by lines *a b* and *c d*, respectively. Fig. 4 is a horizontal section through the apparatus on line *e f*.

This invention relates to apparatus for heating soldering-iron used for melting the solder for works in tinned iron, sheet-zinc, and many of those in copper and other thin metals.

The ordinary soldering-pot is wasteful, a large amount of fuel being necessary to attain the requisite temperature, and no means being provided for regulating the combustion of the fuel according to the amount of work to be executed. On the other hand, the temperature within the pot or furnace cannot be increased or decreased to suit the nature of the work or the kind of metal to be worked upon. Great skill and practice is therefore required on the part of the operator to supply by his judgment the shortcomings of the apparatus, which he can only effect by leaving the irons in the oven more or less time or by allowing them to cool after removing them from the pot, both of which consume much time.

The object of my invention is to produce a portable apparatus, economical in its construction and operation, affording facility to regulate the temperature within the pot or furnace, according to the judgment of the operator; and my invention consists, first, in the construction and arrangement of a pot or furnace for heating soldering-iron by means of lighting-gas mixed with atmospheric air substantially as hereinafter shown and described; second, in the combination, with a pot or its equivalent gas-burner and air-chamber under the arrangement described, of a wire-gauze covering and grate, the two having interposed pumice-stone, as hereinafter shown and described; third, in combining

the pot and gas-heating contrivance with a reverberatory shell to concentrate the heat upon the iron, substantially as hereinafter shown and described.

To enable others to make and use my improved soldering-pot, I shall now proceed to describe its construction and operation.

A in the accompanying drawings represents a cylindrical vessel inclosing the parts constituting my improved apparatus. It is mounted upon a base, B, provided with apertures or made of a plate whose open-work ornamentation will allow of the ingress of the air into the interior of the vessel A. A cover, C, may be applied to give the whole apparatus an air of compactness and to prevent in some measure too great radiation of heat, which may be offensive to the operator. Handles D are also provided to render the whole portable. The description of the exterior will be completed by mentioning the soldering-iron support E—*i. e.*, an inclined plate projecting from the side of the cylindrical vessel immediately underneath the opening G through which the soldering-irons are introduced into the furnace to be heated.

Into the bottom H of the cylinder A, and to project above it, is secured an ordinary or suitable gas-burner, I, mounted upon the end of a flexible tube, whereby gas may be conveyed from any available burner or pipe in the building of the shop. Around this burner, and extending upward, there is a chamber, K, closed on top by means of wire-gauze, the bottom being formed of a small perforated annular disk, *m*, holding the burner and allowing the air to enter through the openings in the base, and to penetrate the interior of the said chamber, where it will mix with the gas, producing an inflammable gas whose heating properties are increased at the expense of its illuminating power. Over the wire-gauze covering are distributed fragments of spongy pumice-stone, the object of which is to retain the heat, producing the same effect as charcoal in its incandescent state. A small grate of parallel bars, *p*, are arranged on top of the pumice-stone to support the soldering-iron while being heated.

In order to concentrate the heat upon the grate and the soldering-tool, I surmount the grate with a reverberatory roof made of brass

or other material which may be easily brought into the requisite shape. This roof or arch R, I prefer to make of semiovoidal form, an opening being provided at the contracted end which corresponds with the opening G in the cylindrical envelope. In the opposite end small holes q q' q'' q''' are cut in the reverberatory shell and the cylindrical vessel for the exit of the vapor or gases generated within the furnace. By this arrangement the furnace does not radiate heat to an extent to incommode the operator, because the air filling the space between the reverberatory dome and the cover of the furnace is a non-conductor of heat.

The operation of the apparatus will be understood by reference to the drawings. Gas being turned on, it will issue from the burner I, mix with the air contained in and supplied to the chamber K, and the mixture will ooze through the wire gauze and pumice-stone, where it may be ignited. The jet of gas may then be regulated at the will of the operator by turning a cock, with which the gas-supply pipe is provided. By this means the temperature may be regulated to suit any kind of work.

Another advantage consists in the great saving of fuel. inasmuch as the supply of gas may be shut off at any moment, so that during

the intermediate hours of work no consumption of fuel is had, while the apparatus may be put in operative condition by simply turning the gas-cock and by applying a match.

Having thus fully described my invention, I claim—

1. The construction and arrangement of a pot or furnace for heating soldering-iron by means of lighting-gas mixed with atmospheric air, substantially as herein shown and described.

2. The combination, with a pot or its equivalent gas-burner and air chamber under the arrangement described, of a wire-gauze covering and grate, the two having interposed pumice stone, as herein shown and described.

3. Combining the pot and gas-heating contrivances with a reverberatory shell to concentrate the heat upon the iron, substantially as herein shown and described.

In testimony whereof I have signed my name to this specification before two subscribing witnesses.

ISAAC CRESSMAN.

Witnesses:

A. POLLOK,

J. L. COOMBS.