

⑫ **EUROPEAN PATENT SPECIFICATION**

- ⑬ Date of publication of patent specification: **31.07.85**
- ⑭ Application number: **81901218.8**
- ⑮ Date of filing: **15.05.81**
- ⑯ International application number:  
**PCT/NO81/00018**
- ⑰ International publication number:  
**WO 82/01860 10.06.82 Gazette 82/15**
- ⑱ Int. Cl.<sup>4</sup>: **B 63 C 9/26, F 41 B 11/00,**  
**F 41 F 1/04, F 42 B 13/56**

⑳ **LAUNCHING APPARATUS FOR DISCHARGING A PROJECTILE CONNECTED TO A LIFELINE OR THE LIKE.**

- |   |   |
|---|---|
| <p>㉑ Priority: <b>02.12.80 NO 803641</b></p> <p>㉒ Date of publication of application:<br/><b>08.12.82 Bulletin 82/49</b></p> <p>㉓ Publication of the grant of the patent:<br/><b>31.07.85 Bulletin 85/31</b></p> <p>㉔ Designated Contracting States:<br/><b>DE FR GB SE</b></p> <p>㉕ References cited:<br/><b>DE-A- 206 154</b><br/><b>GB-A-1 321 893</b><br/><b>GB-A-1 536 672</b><br/><b>US-A-1 072 969</b><br/><b>US-A-1 299 901</b></p> | <p>㉖ Proprietor: <b>HALLARAUNE, Olav</b><br/><b>Hernesveien 7A</b><br/><b>N-8000 Bodo (NO)</b></p> <p>㉗ Proprietor: <b>VALEN, Johan</b><br/><b>Johan Bojers vei 20</b><br/><b>N-8014 Hunstadmoen (NO)</b></p> <p>㉘ Proprietor: <b>JENSEN, Harry</b><br/><b>Hälogalandsgatan 97</b><br/><b>N-8000 Bodo (NO)</b></p> <p>㉙ Inventor: <b>HALLARAUNE, Olav</b><br/><b>Hernesveien 7A</b><br/><b>N-8000 Bodo (NO)</b><br/>Inventor: <b>VALEN, Johan</b><br/><b>Johan Bojers vei 20</b><br/><b>N-8014 Hunstadmoen (NO)</b><br/>Inventor: <b>JENSEN, Harry</b><br/><b>Hälogalandsgatan 97</b><br/><b>N-8000 Bodo (NO)</b></p> <p>㉚ Representative: <b>Forsheden, Jarl et al</b><br/><b>L.A. Groth &amp; Co. AB Västmangatan 43</b><br/><b>S-113 25 Stockholm (SE)</b></p> |
|---|---|

Note: Within nine months from the publication of the mention of the grant of the European patent, any person may give notice to the European Patent Office of opposition to the European patent granted. Notice of opposition shall be filed in a written reasoned statement. It shall not be deemed to have been filed until the opposition fee has been paid. (Art. 99(1) European patent convention).

## Description

The present invention relates to a launching apparatus for discharging a projectile connected to a lifeline or the like, comprising a launching tube which is connected to a source of compressed air via a main valve having rapid valve movement.

Most of the hitherto-known launching apparatuses for discharging lifelines or the like have been based on shooting the projectile by means of gunpowder, or the projectile has been rocket-driven. The advantage of launching a projectile by means of air is that such a device can be utilized anywhere, e.g., even under conditions in which there is a danger of fire breaking out. Such applications would include, for example, at quay installations, on board ships, in dry forests and the like. Launching a projectile with an air-driven device is also inexpensive, and this is of great importance as it allows one almost unlimited practice shooting. The devices in use today, for example on board rescue ships, cost about NOK 400, — per shot, and it is obvious that with such costs, practice shooting sessions are kept to a minimum. An air-driven launching device is also very reliable in operation, since it contains no charge which can deteriorate with prolonged storage. There is thus little risk that an air-driven device for discharging lifelines or the like might not work properly when needed, even following long storage.

The reason that air-driven launching apparatuses for lifelines have not found wider use is that their range has not been sufficiently long. International regulations require that the range be a minimum of 220 meters. Hitherto, this range has not been obtained reliably under all weather conditions with air-driven launching apparatuses.

The problem with air-driven launching devices for lifelines, etc., has been that the air pressure has fallen rapidly following the launch owing to flow resistance, causing compressed air not to follow quickly enough in back of the projectile. With the hitherto-known devices of this type, therefore, the range has been relatively short.

Known from US—A—1.299.901 is a launching apparatus suitable for discharging a projectile connected to a lifeline or the like, comprising a launching tube connected to a source of compressed air via a main valve having a rapid valve movement. A compressed air reservoir is arranged in connection with a launching tube. The main valve is arranged between the reservoir and the launching tube and has a large flow area. The valve is actuated into an open position by means of a pressure-driven servomechanism consisting of a cylinder with a piston which is connected to the main valve. Inlets for compressed air to the cylinder space in back of the piston are provided, wherein a manually-operable valve in a non-actuated position holds said inlet open. The manual actuated valve has a passage for draining air from the cylinder space in back of the piston which is open by operating the manual

valve, while at the same time the inlet for compressed air to the cylinder space is closed, such that the pressure in back of the piston disappears and the piston is pushed back. The front side of the piston being open towards the compressed air reservoir. The valve means have however, an exposed position outside the compressed air reservoir and may easily be damaged. It also is necessary to arrange pipelines outside the launching apparatus.

The object of the present invention is to eliminate the above mentioned drawbacks, and achieve a compact launching apparatus and to protect valve means from damage.

This is obtained according to the invention with a launching apparatus for discharging a projectile connected to a lifeline or the like, comprising a launching tube connected to a source of compressed air via a main valve having rapid valve movement, a compressed air reservoir being arranged in connection with the launching tube, the main valve being arranged between the reservoir and the launching tube and having a large flow area, the valve being actuated into an open position by means of a pressure-driven servomechanism consisting of a cylinder with a piston which is connected to the main valve, inlets for compressed air to the cylinder space in back of the piston being provided, wherein a manually-operable valve in a non-actuated position holds said inlet open, and a compression spring being provided on the back side of the piston which pushes the piston and thereby the main valve into a closed position, and wherein the manually-actuated valve has a passage for draining air from the cylinder space in back of the piston which passage is opened by operating the manual valve, while at the same time the inlet is closed, such that the pressure in back of the piston disappears and the piston is pushed back, the front side of the piston being open toward the compressed air reservoir, and the apparatus is characterized in that the manually-actuated valve is mounted in a holder which is secured inside the reservoir, that the cylinder for the piston is integrated in the holder, and that a passage is provided in the holder for compressed air from a rearward part to a forward part of the compressed air reservoir.

The invention will be explained in greater detail in the following with reference to the accompanying drawing, wherein;

The figure shows a cross section through an embodiment of a launching apparatus according to the invention.

The launching apparatus consists of a preferably cylindrical, tube-shaped pressure chamber 1 which constitutes a reservoir for compressed air. At one end of the chamber, the forward end when the apparatus is in use, a launching tube 2 is connected to the reservoir via an annular flange 3. The annular flange 3 has a passage 4 which corresponds to the passage 5 of the launching tube. The flange 3 is formed with an inclined surface at the inner edge thereof which constitutes a valve seat 6. A strong valve plate 7

having an inclined surface 6a corresponding to the valve seat 6 cooperates with the valve seat. The valve plate 7 is attached to the forward end of a rod 9 which in turn is attached to a piston 10. The piston is movable back and forth in a cylinder 8. The piston 10 is controlled by a steering member 11 which runs in a bore 12. The cylinder 8 is integrated into a holder 13 which by means of spokes 14 is attached to the interior of the reservoir 1. In one of the spokes, a manually operable valve 15 is arranged. In the valve housing 16 and in the spoke in which the valve 15 is placed, an inlet 17 for compressed air is arranged, as well as an outlet 18 to the cylinder space 19 in back of the piston 10. Provided in the valve slide 20 is an air drain passage 21. The slide 20 is extended such that it constitutes an actuating button 22. The reservoir 1 is supplied with compressed air through a nipple 23. The compressed air can be supplied, for example, from a compressed air bottle having a reducing valve such that the air supplied has a pressure of 60 kp. The steering member 11 has an air drain passage 24 for the bore 12 when the piston 10 is pushed backwardly. Also provided is a compression spring 25 which serves as an auxiliary member for holding the valve 7 in place against the seat 6. This will be explained in greater detail below. Fastened to the rearward end of the launching apparatus is a firing lever 26. The firing lever 26 is made of a resilient material, for example a resilient plastic or plastic-coated steel, and in the unloaded state lies a short distance from the end of the actuating button 22. When the lever is pushed inwardly, it will press against the button 22 and the shot will be fired. The purpose of the firing lever is to make the apparatus easier to operate, for example, with numb fingers or with mittens on.

The apparatus operates in the following manner:

When compressed air is supplied through the supply nipple 23, the compressed air flows into the rearward part 1a of the compressed air reservoir 1. Through the passage 17, the compressed air flows through the valve 15 into the space 19 in back of the piston 10 through an inlet 27. The compressed air will also pass through the holder 13 between the spokes, such that compressed air is also found in the forward part 1b of the compressed air reservoir 1. However, the spring 25 will force the valve plate 7 against the seat 6. When firing, the actuator button 22 is pushed in and the slide 20 will be guided inwardly such that the passage 17 is closed while at the same time the outlet 18 from the cylinder space 19 is opened toward the drain passage 21. The compressed air in back of the piston in the cylinder space 19 will thereby disappear, the pressure in the compressed air reservoir 1b will push the piston backwards with great force, and the valve plate 7 will immediately lift away from the seat 6 and the shot will be fired. When the button 22 is released, a spring 27a will return the slide 20 to its starting position and air will once again be admitted in back of the piston 10 and the spring will force the

valve plate 7 into position against the seat 6.

The actuator button 22 will be provided with a safety guard to prevent accidental firing, for example, in the form of a cotter pin or a detachable cover.

### Claims

1. A launching apparatus for discharging a projectile connected to a lifeline or the like, comprising a launching tube (2) connected to a source of compressed air via a main valve having rapid valve movement, a compressed air reservoir (1) being arranged in connection with the launching tube, the main valve being arranged between the reservoir and the launching tube and having a large flow area, the valve being actuated into an open position by means of a pressure-driven servomechanism consisting of a cylinder (8) with a piston (10) which is connected to the main valve (15), inlets (17) for compressed air to the cylinder space (19) in back of the piston being provided, wherein a manually-operable valve in a non-actuated position holds said inlet open, and a compression spring (25) being provided on the back side of the piston which pushes the piston and thereby the main valve into a closed position, and wherein the manually-actuated valve has a passage (21) for draining air from the cylinder space in back of the piston which passage is opened by operating the manual valve, while at the same time the inlet (17) is closed, such that the pressure in back of the piston disappears and the piston (10) is pushed back, the front side of the piston being open toward the compressed air reservoir, characterized in that the manually-actuated valve (15) is mounted in a holder (13) which is secured inside the reservoir (1), that the cylinder (8) for the piston (10) is integrated in the holder (13), and that a passage is provided in the holder for compressed air from a rearward part (1a) to a forward part (1b) of the compressed air reservoir (1).

2. An apparatus according to claim 1, characterized in that the reservoir (1) has at least as large a volume as the volume of the launching tube.

### Revendications

1. Appareil de lancement pour décharger un projectile relié à une ligne de sauvetage ou similaire, comprenant un tube de lancement (2) relié à une source d'air comprimé par l'intermédiaire d'une valve principale ayant un mouvement rapide de valve, un réservoir à air comprimé (1) étant disposé en liaison avec le tube de lancement, la valve principale étant disposée entre le réservoir et le tube de lancement et ayant une grande aire d'écoulement, la valve étant amenée à une position ouverte au moyen d'un servomécanisme entraîné par pression formé d'un cylindre (8) avec un piston (10) qui est relié à la valve principale (15), des entrées (17) étant prévues pour l'entrée d'air comprimé dans l'espace de cylindre (19) en arrière du piston, dans lequel une valve pouvant être actionnée manuellement,

dans une position non actionnée, maintient l'entrée ouverte, et un ressort de compression (25) étant prévu à l'arrière du piston et poussant le piston et donc la valve principale à une position fermée, et dans lequel la valve actionnée manuellement présente un passage (21) pour évacuer l'air de l'espace de cylindre en arrière du piston, ce passage étant ouvert par actionnement de la valve manuelle, tandis qu'en même temps l'entrée (17) se ferme, de sorte que la pression en arrière du piston disparaît et que le piston (10) est repoussé, le côté antérieur du piston étant ouvert vers le réservoir à air comprimé, caractérisé par le fait que la valve actionnée manuellement (15) est montée dans une monture (13) qui est fixée à l'intérieur du réservoir (1), que le cylindre (8) destiné au piston (10) est intégré à la monture (13) et qu'un passage est prévu dans la monture pour de l'air comprimé allant d'une partie arrière (1a) à une partie avant (1b) du réservoir à air comprimé (1).

2. Appareil selon la revendication 1, caractérisé par le fait que le réservoir (1) a un volume au moins aussi grand que le volume du tube de lancement.

#### Patentansprüche

1. Abschußvorrichtung zum Abschießen eines mit einer Rettungsleine od.dgl. verbundenen Projektils, umfassend ein über ein Hauptventil mit Schnellschlußbewegung an eine Druckluftquelle angeschlossenes Abschußrohr (2) und einen mit dem Abschußrohr in Verbindung stehenden

Druckluftbehälter (1), welches Hauptventil zwischen dem Behälter sowie dem Abschußrohr angeordnet ist und einen großen Durchflußquerschnitt aufweist, wobei das Ventil durch einen druckluftbetriebenen Servomechanismus, der aus einem mit dem Hauptventil (15) verbundenen Zylinder (8) mit Kolben (10) besteht, in eine Offenstellung bringbar ist und Einlässe (17) für Druckluft zum Zylinderraum (19) hinter dem Kolben vorgesehen sind, und wobei ein manuell betätigbares Ventil in einer nicht beaufschlagten Stellung den genannten Einlaß offen hält, und an der Rückseite des Kolbens eine Druckfeder (25) vorgesehen ist, die den Kolben und dadurch das Hauptventil in eine geschlossene Stellung drückt, welches manuell betätigte Ventil einen Durchlaß (21) zum Ableiten von Luft aus dem Zylinderraum hinter dem Kolben aufweist, welcher Durchlaß durch Betätigung des manuellen Ventils zu öffnen ist, während gleichzeitig der Einlaß (17) geschlossen wird, so daß der Druck hinter dem Kolben verschwindet, der Kolben (10) zurückgedrückt wird und die Vorderseite des Kolbens zum Druckluftbehälter hin offen ist, dadurch gekennzeichnet, daß das manuell betätigbare Ventil (15) in einem innerhalb des Behälters (1) befestigten Halter (13) angeordnet ist, daß der Zylinder (8) für den Kolben (10) im Halter (13) integriert ist, und daß im Halter ein Durchlaß für Druckluft von einem hinteren Teil (1a) zu einem vorderen Teil (1b) des Druckluftbehälters (1) vorgesehen ist.

2. Vorrichtung nach Patentanspruch 1, dadurch gekennzeichnet, daß das Volumen des Behälters (1) wenigstens ebenso groß ist wie das Volumen des Abschußrohres.

40

45

50

55

60

65

4

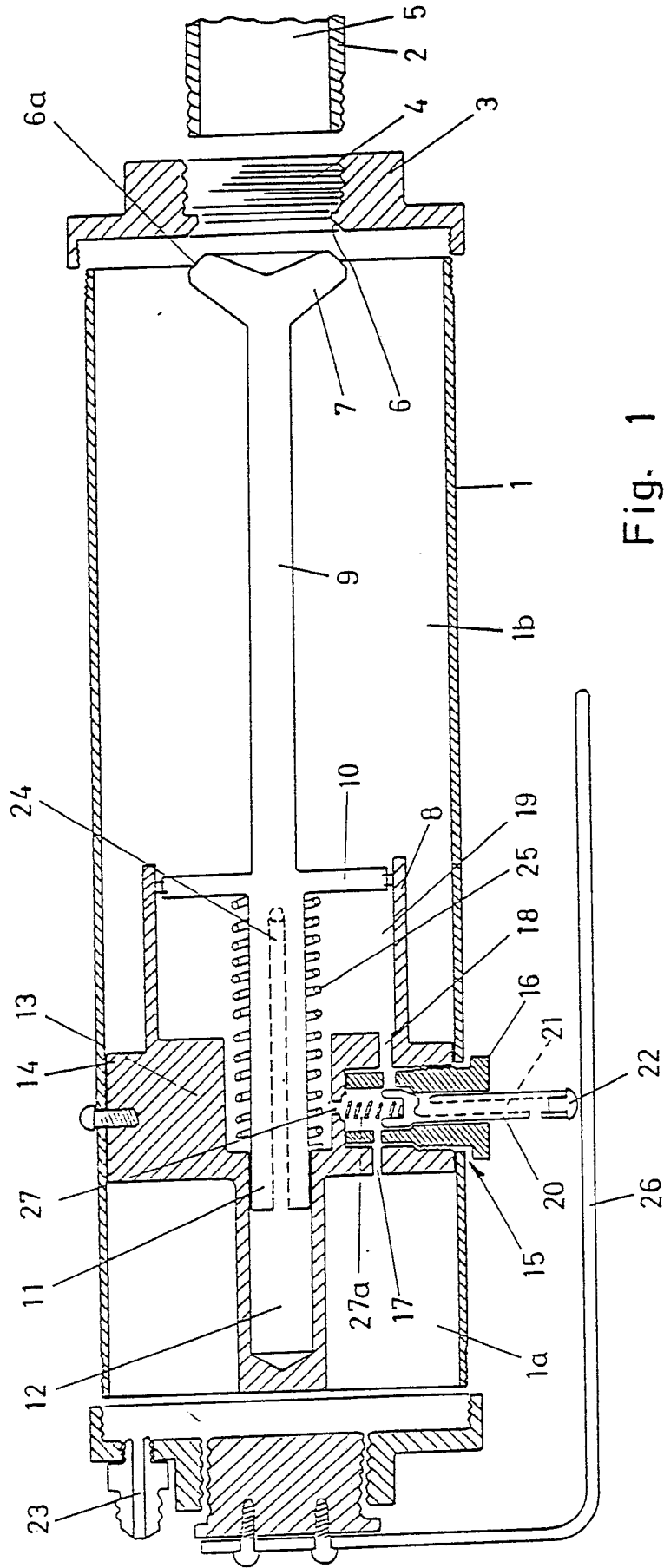

Fig. 1