



- (51) International Patent Classification:
B61B 13/00 (2006.01) *G09G 5/00* (2006.01)
- (21) International Application Number:
PCT/US2017/021818
- (22) International Filing Date:
10 March 2017 (10.03.2017)
- (25) Filing Language: English
- (26) Publication Language: English
- (30) Priority Data:
62/307,408 11 March 2016 (11.03.2016) US
- (71) Applicant: **HYPERLOOP TRANSPORTATION TECHNOLOGIES, INC.** [US/US]; 11844 Jefferson Blvd, Culver City, California 90230 (US).
- (72) Inventors: **AHLBORN, Dirk**; 11844 Jefferson Blvd, Culver City, California 90230 (US). **HEITGER, Jan**; Marcel-Breuer-Str. 15, 80807 Munich (DE). **OROZCO, Diego**; Marcel-Breuer-Str. 15, 80807 Munich (DE). **ROUSSEAU, Tiphaine**; Marcel-Breuer-Str. 15, 80807 Munich (DE). **SCHART, Dirk**; Marcel-Breuer-Str. 15, 80807 Munich

(DE). **STELZLE, Wolfgang**; Marcel-Breuer-Str. 15, 80807 Munich (DE).

(74) Agent: **LEE, Elizabeth**; Lucas & Mercanti, LLP, 30 Broad Street, 21st Floor, New York, New York 10004 (US).

(81) Designated States (unless otherwise indicated, for every kind of national protection available): AE, AG, AL, AM, AO, AT, AU, AZ, BA, BB, BG, BH, BN, BR, BW, BY, BZ, CA, CH, CL, CN, CO, CR, CU, CZ, DE, DJ, DK, DM, DO, DZ, EC, EE, EG, ES, FI, GB, GD, GE, GH, GM, GT, HN, HR, HU, ID, IL, IN, IR, IS, JP, KE, KG, KH, KN, KP, KR, KW, KZ, LA, LC, LK, LR, LS, LU, LY, MA, MD, ME, MG, MK, MN, MW, MX, MY, MZ, NA, NG, NI, NO, NZ, OM, PA, PE, PG, PH, PL, PT, QA, RO, RS, RU, RW, SA, SC, SD, SE, SG, SK, SL, SM, ST, SV, SY, TH, TJ, TM, TN, TR, TT, TZ, UA, UG, US, UZ, VC, VN, ZA, ZM, ZW.

(84) Designated States (unless otherwise indicated, for every kind of regional protection available): ARIPO (BW, GH, GM, KE, LR, LS, MW, MZ, NA, RW, SD, SL, ST, SZ, TZ, UG, ZM, ZW), Eurasian (AM, AZ, BY, KG, KZ, RU, TJ, TM), European (AL, AT, BE, BG, CH, CY, CZ, DE, DK, EE, ES, FI, FR, GB, GR, HR, HU, IE, IS, IT, LT, LU,

[Continued on next page]

(54) Title: AUGMENTED WINDOWS

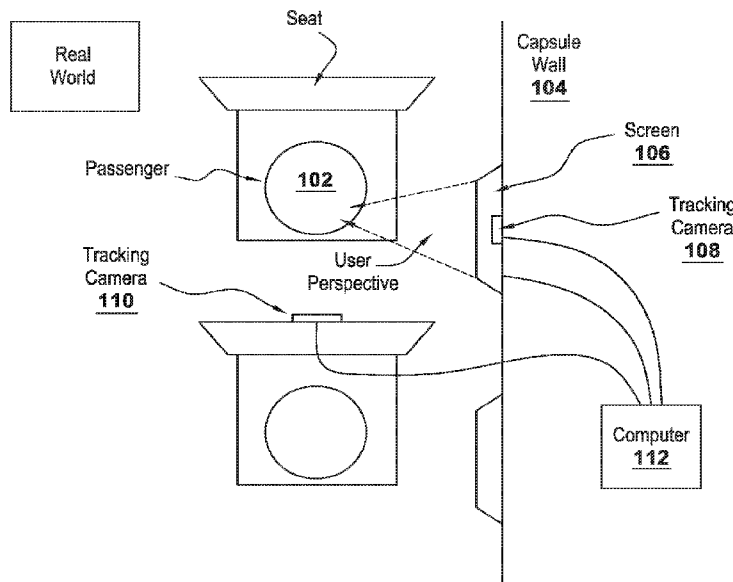

FIG. 1

(57) Abstract: The windowless prototypes of various evacuated tube transportation (ETT) based transportation systems, such as Hyperloop-based transportation systems, has the negative feel of an enclosed space. The lack of any kind of outside reference, the unknown sounds and the tremendous speed of the capsule/pod would surely cause anxiety with several passengers. A representation of the outside world shown within the pod/capsule using augmented windows alleviates this claustrophobic environment. At least for the closest passenger to the window, the illusion of looking out on a landscape is achieved using such augmented windows.



LV, MC, MK, MT, NL, NO, PL, PT, RO, RS, SE, SI, SK, **Published:**
SM, TR), OAPI (BF, BJ, CF, CG, CI, CM, GA, GN, GQ, — *with international search report (Art. 21(3))*
GW, KM, ML, MR, NE, SN, TD, TG).

AUGMENTED WINDOWS

Cross-reference to related application

This application claims the benefit of U.S. Application Serial Number 62/307/408
5 filed March 11, 2016, the entire contents of which are incorporated herein by reference.

BACKGROUND OF THE INVENTION

Field of Invention

The present invention relates generally to the field of evacuated tube transportation
10 (ETT) technologies. More specifically, the present invention is related to augmented
windows provided within evacuated tube transportation systems, such as Hyperloop-based
transportation systems.

Discussion of Related Art

15 Passengers of public and private transportation are used to being able to see out of
their vehicle. Over-ground vehicles, such as buses or trains, but also underground trains
and airplanes offer windows so that passengers have a reference for the movement that
they experience in the vehicle

20 Even though riders of public transportation do experience less stress than those of
private vehicles, they do experience some level of stress. This stress might consist of
psychological issues, such as being enclosed in a small space, proximity to strangers and

others, as well as physiological issues, like insufficient leg space, nausea, inability to go to a bathroom.

5 Pods within evacuated tube transportation (ETT) systems, such as Hyperloop-based systems, do not have any windows so travelers do not have to be exposed to fast moving scenery. Such closed pods (and potentially closed tubes surrounding them) provide an unusual, claustrophobic experience for some passengers. This contrasts with subways, where windows are placed within subway cars to avoid a claustrophobic environment.

10 Introducing a public transportation vehicle that does not have windows might add to some of those stress-producing issues or even create new ones. For example, having no windows might cause the passenger to feel even more enclosed (psychological stress), having no visible reference for the experienced movement might lead to nausea (physiological stress).

15 Therefore, what is needed is a mechanism, which when installed in such ETT systems, avoids providing this potential claustrophobic environment. Embodiments of the present invention are an improvement over prior art systems and methods.

SUMMARY OF THE INVENTION

The present invention provides an augmented window system implemented in a capsule traversing an evacuated tube transportation (ETT) structure, the augmented window system comprising: (a) a display; (b) a tracking camera tracking location of a passenger within the capsule, the passenger located proximate to the display; (c) a computer: receiving a first location of the passenger within the capsule and rendering, on the display, a first perspective to the passenger corresponding to the first location; receiving a second location of the passenger within the capsule and rendering, on the display, a second perspective corresponding to the second location, the second perspective different than the first perspective; and wherein the first and second perspectives are derived from pre-recorded video data (or real-time 3D renderings). This process is repeated every time the user moves to a different location within the capsule and, as long as the user is proximate to the display, new perspectives are computed in real-time and displayed in the augmented window.

15

The present invention also provides a method as implemented in an augmented window implemented within a capsule traversing an evacuated tube transportation (ETT) structure, the method comprising: receiving, from a tracking camera located within the capsule, a first location of a passenger within the capsule and rendering, on a display within the capsule, a first perspective to the passenger corresponding to the first location, the passenger located proximate to the display; receiving, from the tracking camera located

20

within the capsule, a second location of the passenger within the capsule and rendering, on the display, a second perspective corresponding to the second location, the second perspective different than the first perspective; and wherein the first and second perspectives are derived from pre-recorded video data (or real-time 3D renderings). This process is repeated every time the user moves to a different location within the capsule and, as long as the user is proximate to the display, new perspectives are computed in real-time and displayed in the augmented window.

BRIEF DESCRIPTION OF THE DRAWINGS

10 The present disclosure, in accordance with one or more various examples, is described in detail with reference to the following figures. The drawings are provided for purposes of illustration only and merely depict examples of the disclosure. These drawings are provided to facilitate the reader's understanding of the disclosure and should not be considered limiting of the breadth, scope, or applicability of the disclosure. It should be noted that for clarity and ease of illustration these drawings are not necessarily made to scale.

15 FIG. 1 illustrates a scenario where one or more tracking cameras are used to track the location of a passenger, where the location is used to render differing perspectives in an augmented window.

FIG. 2 illustrates how the virtual camera is set in an equivalent 3D pose (position and orientation) and frustum to that of the user in the virtual scene, from which the content is rendered.

FIG. 3 and FIG. 6 illustrate a projection of the rendered scenery (virtual objects) with the correct perspective for the user.

FIG. 4 illustrates how each user has their own perspective.

FIG. 5 and FIG. 7 illustrate how the setup tracks the passenger and calculates the view of the passenger as he/she moves in relation with the position of the window.

FIG. 8 illustrates a setup with multiple users sharing a display, with each user having their own perspective rendered on the same augmented window.

FIG. 9 depicts an example flow chart of how perspectives are rendered based on the teachings of the present invention.

FIGS. 10-11 depict a non-limiting example of the framework of the capsule showing one seating arrangement within the capsule.

FIG. 12 depicts the frame that holds the display.

DESCRIPTION OF THE PREFERRED EMBODIMENTS

While this invention is illustrated and described in a preferred embodiment, the invention may be produced in many different configurations. There is depicted in the drawings, and will herein be described in detail, a preferred embodiment of the invention, with the understanding that the present disclosure is to be considered as an exemplification

of the principles of the invention and the associated functional specifications for its construction and is not intended to limit the invention to the embodiment illustrated. Those skilled in the art will envision many other possible variations within the scope of the present invention.

5

Note that in this description, references to “one embodiment” or “an embodiment” mean that the feature being referred to is included in at least one embodiment of the invention. Further, separate references to “one embodiment” in this description do not necessarily refer to the same embodiment; however, neither are such embodiments mutually exclusive, unless so stated and except as will be readily apparent to those of ordinary skill in the art. Thus, the present invention can include any variety of combinations and/or integrations of the embodiments described herein.

The present invention’s pod does not have any windows, but is provided with one or more augmented windows, also called virtual windows, which overcomes the claustrophobic environment prevalent in prior art pod systems. The present invention creates a completely new passenger experience, where the passenger can see a real or simulated environment (i.e., simulated environment when staying in a station, leaving the station, and during the journey). In one embodiment, the perspective of the augmented window changes according to the position of the passenger within the pod, where such a change in perspective gives the passenger the impression of being near a real window. In

15

20

addition to the augmented/virtual content, entertainment and information are other aspects which can also be displayed in the present invention's augmented window.

Passenger Experience

5 The right passenger experience depends on the passenger's activity and locations (within the pod), as well as on the current section of the travel. For example, three (3) pre-defined situations are considered:

- 1) boarding (standing/walking),
- 2) acceleration/deceleration (sitting), and
- 10 3) cruising (sitting).

In one embodiment, for each of the situations described above, different content can be shown in order to reach a realistic effect and a good mix of entertainment and information. Three types of content that may be shown are:

- 15 1) realistic scenery (simulated outside view),
- 2) information, and
- 3) entertainment.

In a non-limiting example, the following table (i.e., TABLE 1) shows for different
20 phases, what type of content may be rendered (e.g., real scenery, entertainment content, information, etc.).

Type	Category	Phase	Details
Live Imagery	Real scenery	Boarding	Camera filming in the station while boarding
Recorded real imagery	Real scenery	Accel/Decel	Film of the real environment along the track without specific conditions like current weather
3D content from movies	Entertainment	Cruising	3D scenes for creating virtual environments
3D Stereoscopic	Entertainment	Cruising	Stereoscopic content, 360 degree video
2D Movies	Entertainment	Cruising	Regular movies played on the various screens of the pod
Hyperloop Worlds	Entertainment	Cruising	Individual prepared content for turning the pod into a special world like an aquarium, in space (CGI)
Travel Info	Information	Cruising	Details about trip as on the airplane (Time, route, map, etc.)
News content	Information	Cruising	Personalized News channels like Flipboard™ etc.
Own content	Information	Cruising	Connect your smartphone and use your data
Branded content	Entertainment	Cruising	Advertisements, Trailer, Branded worlds
Augmented Reality content	Information	Boarding; Accel/Decel; Cruising	Enhanced digital information superimposed to the real scenery
Window closing/opening	Phase change	General	Once boarding is completed windows close/become black for a moment

TABLE 1

In order to provide a unique experience while traveling within the ETT, different levels of augmented experiences may be provided. In one embodiment, when a passenger is "looking outside" through an augmented window, live or recorded imagery of the

5

surrounding open environment may be shown. Another embodiment involves real-time simulated imagery, which has the advantage of allowing change to the perspective of the virtual window with low effort. A big challenge in such scenarios is to calculate the right perspective (of the passenger), which requires knowing what each passenger sees when they are looking out of their virtual window. The present invention uses tracking or another solution to know where the passenger's point of view is located.

Hardware

- Conventional screens may be used for implementing augmented windows.
- Taking large screens, but only using part of such a large screen for the real sceneries and show banner or other things to hide a part of the screen.

Tracking of passenger's view

1. Face tracking could be done with specific camera like from Wii remote with head-mounted sensor bar (two infrared LEDs) that requires the user to wear some device. This is not preferable since the user must wear a sensor.
2. Face recognition / eye tracking / head tracking could be done using a conventional RGB camera.
3. Passenger tracking could be done using an RGB-D (depth) camera, like those of Microsoft Kinect or Intel RealSense.
4. The position of the passenger may be inferred based on the phase of the journey.

Pod mock-up and planned equipment

Some non-limiting assumptions of the pod and the planned equipment are as follows:

- One screen may be used for each row.
- Screens may be fitted vertically (or in any other configuration) to the side panels
5 of the pod/capsule.
- Moreover, various screen sizes may be used in conjunction with the present invention as part of the display.
- Camera may be fitted to backside of seat/inside panels.
- Different interior arrangement of seat rows within a pod are envisioned for different
10 classes (i.e., different arrangements for local, economy, or business)

The present invention's "Augmented Windows" can improve the experience of inhabitants of a windowless, enclosed space. Particularly, augmented windows may be used in ETT systems, such as Hyperloop-based transportation systems, where the present
15 invention's augmented window simulates a window using a screen and software to depict a 3-dimensional landscape that appears as if it was behind the screen, like a real landscape appears behind a window.

As noted in the background, ETT systems, such as Hyperloop-based transportation
20 systems, are unable to have windows since the pod/capsule moves inside a tube (which itself may not be transparent) and must withstand tremendous pressure (where having

windows increases structural weakness). Augmented Window describes the technology that creates the illusion of looking through a window while looking at a screen. Without Augmented Windows, passengers on the train would have to face the stress noted in the background. The present invention's augmented windows offer passengers extended value
5 (over regular windows) by being able to depict digital, real-time information with which the viewer can interact.

For simplicity, the initial description is provided if the tube in which the pod/capsule is travelling in an ETT system is transparent. In this example, the augmented
10 window comprises a camera mounted to the back of a video screen, allowing the viewer of the video screen to see what happens behind the screen in real-time (based on data received from the camera, which is processed and sent to the video screen in real-time). This basic case, however, only works well if the user sits in a static position relative to the screen, never moving their head and the content of the video is far away from the camera. An issue
15 arises when the viewer moves their head by more than a few inches, the illusion is broken and the screen's image appears as flat as it is (as the perspective of the viewer never changes).

Head-, eye-, or face-tracking may be used to uphold the illusion of looking through
20 a window by placing the recorded content (i.e., recorded behind the screen) so that the viewer always sees what they would when looking through the frame of an actual window.

For example, when a person moves to the left, facing the window, they will see things that are to the right, outside of the window. Also, when a person moves from being further away from the window to being closer to the window, they will see more of what is outside of the window as the window takes up more space in their field of view. FIG. 5 depicts an example of such movement providing adaptive perspective, where the user moves from a position indicated by circle **502**, having an associated perspective shown as **503**, to position indicated by circle **504** having an associated perspective shown as **505**.

A side view of such adaptive perspective is shown in FIGS. 6-7, where FIG. 6 depicts the side view of the perspective as viewed by the user at the initial position (i.e., position **502** in FIG. 5), and FIG. 7 is the side-view of the perspective after the user has moved to a second position (i.e., position **504** in FIG. 5), where the change in position from the initial to the second position is tracked using the tracking camera. Moving and scaling a planar video source might be sufficient in some cases. In other cases, the landscape viewed through the screen is recreated in 3D space to give the best illusion.

The setup tracks the person and calculates the view of the person as he/she moves in relation with the position of the window (FIG. 5 and FIG. 7), and sets the camera in an equivalent 3D pose (position and orientation) and frustum to that of the user in the virtual scene, from which the content is rendered (FIG. 2). Figure 2 shows the calculated perspective and the virtual terrain “behind” the augmented windows relative to the

perspective as generated by the rendering camera. To achieve this, a virtual camera is placed in a position in the virtual world (where the position is equivalent to that of the person's view in the real world). The result is a projection of the rendered scenery (virtual objects) with the correct perspective for the user (FIG. 3 and FIG. 6).

5

The rendered scenery (virtual objects) might come from live or recorded footage, 3D rendered CGI, real-time rendered 2D or 3D, or a mix of all the mentioned possibilities.

Perspective is calculated for each user separately (FIG. 4).

10

Furthermore, the present invention's augmented windows also give creators the ability to place additional content in the screen-space landscape that do not exist in reality where, in a non-limiting example, such additional content could include a pre-recorded video or interactive 3D content.

15

When interacting with virtual 3D content on a monitor, the human body poses certain requirements for the displayed content in order to avoid nausea. Some people are affected by this more than others. In general, people can fall victim to "motion sickness" when the virtual environment moves at a different rate or direction than they do. Passengers in moving vehicles can suffer from this when reading books (which do not move at all, compared to the vehicle) as well as watching movies or playing video games (which do

20

move, but generally not in relation to the travel that the passenger is experiencing, the latter even motivated by the player's conscious input).

Applied to the present invention's augmented window case for ETT systems, such as Hyperloop-based transportation systems, there are two distinct vectors of motion that need to be depicted just right to avoid this motion sickness. Firstly, the rate at which the virtual content moves, simulating the ETT pod's/capsule's travelling speed. This does not need to be 100% accurate always. Only during the acceleration phase of the journey should the depiction of speed be somewhat accurate. However, once the acceleration phase is complete, the rate of speed cannot be accurately felt by the passenger, except while cornering (around a curve). However, such curves are minimally present in the general construct of Hyperloop-based transportation system.

Secondly, the rate of the eye tracking (or head tracking) needs to accurately reflect the viewer's movement. This needs to be significantly more accurate than the virtual content's traveling speed, since the eye tracking reflects the immediate relationship between the viewer and the "window". The "framerate" of the capture, the accuracy of the capture and the resulting calculation of the virtual content's scale and position are the essential factors for reducing nausea.

20

To have a landscape for the viewer to see when looking "through" the Augmented window, it will have to be recorded first. Depending on the physical size of the window and the proximity of the viewer to the window, the resolution of the camera image must be chosen. Generally, the closer the viewer is to the window, the more fidelity the camera must provide. Similarly, the larger the window is, the higher the camera's resolution must be. If the viewer has access to a large viewing angle of the screen, the image will even have to be composed of several camera images.

To produce an image having an accurate feel, the recording device should be mounted closely to the rear side of the augmented window, to create the illusion of looking *through* a screen. In an array of several windows, each one would need a separate camera for a realistic experience. In some cases, a creator of an augmented window would use not only one camera but a "camera rig" on an augmented window to create a wrap-around landscape for the viewer to explore.

Because the creator of the Augmented Window cannot anticipate, which parts of the image the viewer will focus on, the camera should be set up to have very little or no depth of field. This is a feature that many modern cameras of small form factor have anyway.

The application of such augmented windows for ETT-based transportation systems, such as Hyperloop-based transportation systems, is a special case. In the preferred embodiment for such ETT-based transportation systems, the images displayed in the Hyperloop's Augmented Windows is not a live stream, but is based on previously recorded data. Since the vehicle travels inside a tube, cameras cannot be mounted on the outside of the vehicle because they would be recording the inside of the tube's wall. An alternate embodiment is envisioned where cameras are mounted outside of the tube, where such cameras either should have their own high-speed locomotion system (that matches the speed of the capsule/pod) or such cameras are arranged in a dense array spanning the entire length of the track. Such alternative embodiments are on the expensive side. In the above-noted preferred embodiment, the solution involves recording the entire track in high fidelity stereoscopic 3D once for each side (i.e., once from the origin to the destination, and another time when traveling from the destination to the origin), on the outside of the tube to be played back later.

Stereoscopic 3D refers to two cameras (or camera rigs) used to record the image, where there is one rig for each eye. To create a realistic 3D experience, each pair of cameras needs to be apart the same distance the average human eyes are apart. This distance is called the Inter-Pupillary-Distance or IPD.

As an analog to the fidelity of the recorded image, the screen, which the landscape is projected on, should have a high enough resolution for the viewer to appreciate it. If the user moves right up to the screen of the augmented window, its pixel density needs to hold up to scrutiny and be appropriately high. Many displays have a narrow optimal viewing angle, usually head on. If viewers are likely to be in a position out of this angle, they will not have an optimal experience and a monitor with different characteristics is needed. In contrast, if the window is designed to be relatively small (like in an airplane) or access is constricted (e.g. by a narrow hallway), a less sophisticated display may be sufficient.

There are different ways to display stereoscopic images on modern screens, although most of them involve the use of special glasses for them to work. A subsection of today's 3D-enabled screens makes use of auto-stereoscopy, a selection of technologies that allow seeing 3D images without wearing glasses. In short, these displays use an array of microscopic lenses or shutters to channel the light of individual columns of pixels into the right or left eye, depending on the viewing angle. Most of these displays, however, work only in a very constricted field of view.

A way to improve the augmented window experience, particularly with regards to ETT systems, such as Hyperloop-based transportations systems, is to adapt the depicted landscape to the viewer's position. To do this, a camera, *pointing at the viewer*, is required. FIG. 1 depicts an example scenario where a passenger **102** seated within a capsule/pod

(having a capsule wall **104**) with a computer **112** (it should be noted that this computer is located within the capsule, and is only shown outside of the capsule for convenience) that provides, in the preferred embodiment, pre-recorded data to be shown in a screen **106**. A tracking camera **110** is pointed at the passenger **102**, whose perception is based on what he
5 views on the screen **106**. It should be noted that there could be more than one tracking camera per passenger. For example, in addition to the tracking camera **110** that is in front of the passenger's seat, there could be an additional tracking camera **108** that may be either part of, or attached to, the screen **106**. Based on data from such tracking cameras **108** and
10 **110**, the computer can vary the perspective of the user shown on screen **106** to give a more realistic feel of peering into a window. This camera generally does not have to be of high quality, as its image is never shown to the viewer. The software using the camera often operates at a relatively low resolution and generally does not even need color information. However, it does need to be strong enough to detect people from all positions that the augmented window can be seen from.

15

FIGS. 10-11 depict a non-limiting example of the framework of the capsule showing one seating arrangement within the capsule. FIG. 12 depicts a non-limiting example of a frame that holds the display in the capsule.

20

Displaying a high-resolution real-time video stream does require a moderate amount of processing power. For a singular, static augmented window this power should

be manageable and inexpensive. Commercially available streaming hardware might be employed here. If the setup is meant to be more dynamic and adapt to the viewer's position, more computation power is required (e.g., to determine the viewer's head- or eye-position and triangulate the needed position of the viewed content, or to position the virtual landscape, in some cases in a 3D real-time renderer). Out-of-the-box hardware is rarely
5 suitable for this task. The components should be manually configured and calibrated.

No matter how elaborate the simulation of the landscape, there needs to be software that translates the entirety of the recorded landscape to the actual pixels of the display
10 employed. Depending on the detail level of the simulation, the software used can range from readily available streaming-software to specialized custom software.

On the low-end spectrum for an installation without eye or head tracking, the camera image merely needs to be streamed to the screen. There might not even be any
15 software (other than that used by the recording device and the screen) necessary at all for this kind of setup. Once additional content is displayed on the screen, it should be added using a compositing program.

Any Augmented Window that tracks the eyes of the viewer creates a virtual image
20 that is bigger than the actual pixel count of the monitor. Since the portion of the image that the viewer sees increases in scale, the further the viewer moves away from the screen, the

resolution of the virtual landscape needs to be quite large. To guarantee an optimal view from any angle, the virtual landscape needs to exist as a hemi-sphere. To maintain this deformation as the viewer moves around the window, real-time 3D software needs to be employed.

5

Because such a high resolution is required and such a high field of view must be maintained, the image of one camera is often not enough to support the Augmented Window (although, this is rapidly changing with the availability of single cameras that can record 180° or 360° content right out-of-the-box). The virtual landscape on the "other side" of the window will be composed of the images of several cameras. This requires software capable of "stitching", compositing several images into one, large, and in this case, distorted, image.

10

Once the image is created, it will have to be cropped, scaled and flattened to be displayed on the pixels of the display. Most of the types of software described above already have a built-in solution for displaying (rendering) the needed image to the connected screen. Commercially available 3D engines usually offer a way to export executables that work on a wide range of hardware. Depending on the hardware used, the software should reduce the fidelity of the virtual landscape in order to achieve a performance matching ergonomic requirements, i.e. achieving a comfortable framerate.

15

20

The "framerate" means, how many times in one second the virtual position of the viewer is updated. There can be many different framerates in one application. The rate at which the screen flashes its pixels (usually 60 Hz or 60 frames per second), the rate at which the virtual landscape is moved and the rate at which the position of the viewer's eyes is determined. Ideally, all of these are the same. Realistically, the latter function has the lowest framerate, as the interpretation of the inside camera's image finding the viewer's eye position cannot be done 60 times a second by most available software or hardware solutions.

As described above, the requirements for a face or eye tracking algorithm are very specific. It needs to provide the position of the face in 3D space. However, (at the current state, for one viewer) it does not have to provide information on the viewer's face's rotation or gaze direction. It also does not need additional information e.g. the viewer's sex or age. The updates on this information need to be very rapid(for example, at a rate of 60Hz). However, potential exists for both the display and the tracking hardware to work at higher rates (as such rates are dictated by processing power, camera type, etc.).

Instead of displaying the outside landscape realistically, information or recreational content could be displayed, placed in the virtual landscape.

The displays used in the train could feature touchscreens, making the content displayed on them interactive. This, however, would not work well with stereoscopic screens. Focusing the eyes on their own finger, the viewer would break their 3D experience.

5 In one embodiment, the screens could be used to display advertisement. They could show banners at the edges of the screen but also augment the virtual landscape with three-dimensional content such as billboards but also animated, volumetric content like attacking creatures for an upcoming monster movie.

10 Advertisement - The Walking Dead: Bus Stop Installation

The setup is a rather simple one: One of the inside panels of a Vienna bus stop, usually reserved for advertisement posters, is replaced with a screen of the same format. Displayed on the screen is the camera image of the other side of the screen. The camera is placed in a way to simulate looking through a sheet of glass to somebody sitting inside the
15 bus stop.

Once a person sits down on the bench, characters from the show "The Walking Dead" appear in the "window" and start to scare the viewer by attacking actors composited into the virtual landscape or pounding on the Augmented Window. To resolve the situation,
20 eventually the title of the show and other textual information appears.

This is effective because it appears as if gruesome violence is happening in the real environment and the actors appear to be interacting with the viewer. On the other hand, the experience is quite limited, because it only works, if the viewer sits very still in one spot (the bench). This one-time installation was extensively filmed and very gated because, obviously, the subject matter of the advertisement was very unsuitable for the public. The footage recorded of the installation was itself used as an advertisement; both for the show, and for the creators of the event. Such advertising implementations are envisioned as part of the ETT transportation augmented window.

Static installations, like "The Walking Dead", and even more so tracked applications have the problem that they only appear realistic for one person. People who necessarily have to watch the display from other angles do not get the same effect or even physically stressful effects from their experience of the same installation. This has, until now, limited the possibilities of multi-target Augmented Windows.

As noted earlier, in the embodiment where the passengers are provided with a real-time image provided using outside camera(s), such camera(s) would either have to travel at the same speed as the Hyperloop, or cameras would have to be mounted along the entire length of the track. Maintaining such an array would cost a significant amount of time and resources.

Alternatively, as per the preferred embodiment, it would be more practical to record the track once, allowing for a single set of equipment and a safe speed for that equipment. The camera rig used for this recording would have to be sophisticated enough to record the entire virtual environment for one side of the Hyperloop car. It would not record both sides at once, because one side of the 360° image would always see the Hyperloop's tube, which would realistically never be seen from the tube itself. This means recording a hemisphere worth of landscape, once for each eye to create a stereoscopic effect. Unfortunately, this endeavor would not be as easy as mounting cameras on top of a pole that extends from the roof of a car. The camera array used for this would have to be motion controlled and balanced to always be at the same height (as compared to sea level). A constant speed of the vehicle during the recording cannot be guaranteed, which is why the *speed of the filming vehicle* would have to be recorded in order to ensure a constant speed on *playback* of the video footage.

This entire recording would have to be done once for daytime travel and once for nighttime travel. Furthermore, it would have to be recorded once for each weather condition and once for each season, multiplied by two for day and nighttime. Some of these conditions could be simulated, however.

Since the entire train ride would be one video file (or rather, one for each side) the task of the rendering software would not be to stitch together a set of camera images in

real-time but rather to play back the video at the right speed. Of course, the Hyperloop would not be going the exact same speed at the exact same point each journey, the video's playback speed would have to be coupled with the car's actual rate of speed in real-time. Because of this and the sheer amount of data throughput a high-resolution stereoscopic
5 hemisphere would require, standard video players could not handle this task. On top of that, the hemisphere, or rather the passe-partout that the viewer will see, will still have to be moved while the viewer's eyes are being tracked. The entire display mapping would have to be done by a specialized, custom software. Infrastructure capable of this is already employed today.

10

As drones, especially flying ones, are becoming more popular and prolific, the recording process might become more automated or could be performed more often than using a vehicle travelling on the ground. The cameras used for recording would not have to be mounted in one, heavy rig but might do their recording individually, with the image
15 being composed later.

15

The second iteration of the Nintendo 3DS handheld console already offers an adaptive, autostereoscopic screen. At the experimental stage are different technologies that can control the light of each pixel for each angle, enabling them to display different images
20 for different angles of the screen. The result would be that one person could see a different image for each eye on the same screen, without using glasses.

20

As each pixel can change color several times over the course of its nearly 180° rotation, it would also be feasible to not only project to the two eyes of one viewer, but also all of the other viewer's eyes, enabling all of them to see their own version of the image in 3D. However, as viewers might be very close to each other, there could be overlap, due to the pixels only rotating in the horizontal direction.

5

Users could wear devices, like e.g. 3D glasses, to not only allow them to see in stereo, but also assist the tracking.

10

FIG. 8 illustrates a setup with multiple users sharing a display, with each user having their own perspective rendered on the same augmented window. Auto stereoscopic and light field displays allow not only the user to see the content in stereo, but could allow multiple users to have independent perspective correct views.

15

FIG. 9 depicts an example flow chart of how perspectives are rendered based on the teachings of the present invention. While the passenger is sitting next to the augmented windows (step **902**), he/she is recorded by a camera that provides the augmented window application with an RGB-stream and a depth-stream (step **904**). From this information, the augmented window application running in a computer within the capsule reads a 3D-position of the passenger's face (step **906**) (optional adjustments are also possible for 3D

20

positions (step **908**)). To derive the perspective of the passenger, looking through the window, his 3D-position gets applied to the rendering camera of the augmented window application (step **910**). With the position of the rendering camera and the corners of a given reference window (the virtual representation of the real window, the passenger would look
5 through), a frustum is calculated (step **912**) and applied afterwards to the rendering camera itself (step **914**). With the new frustum, the image of the camera, showing the new perspective, is rendered to the display (step **916**). As the user moves, the position of the rendering camera and the calculation of the frustum gets updated, to always render in the right perspective.

10

Motion sickness is a well-known phenomenon, especially in the VR field, where low frame rates or wrong tracking cause sickness. In general, in closed vehicles, motion sickness is common, caused by how the senses perceive movement. Augmented Windows alleviate claustrophobia by making the capsule look open. Augmented Windows alleviate
15 motion sickness by showing proportional acceleration, deceleration and speed in the rendered scenery, and so diminishing the discrepancy between sight and the vestibular system. The key word is proportional acceleration, deceleration and speed shown in the augmented windows don't necessarily have to be identical, but must at least be proportional.

20

Many of the above-described features and applications can be implemented as software processes that are specified as a set of instructions recorded on a computer readable storage medium (also referred to as computer readable medium). When these instructions are executed by one or more processing unit(s) (e.g., one or more processors, cores of processors, or other processing units), they cause the processing unit(s) to perform the actions indicated in the instructions. Embodiments within the scope of the present disclosure may also include tangible and/or non-transitory computer-readable storage media for carrying or having computer-executable instructions or data structures stored thereon. Such non-transitory computer-readable storage media can be any available media that can be accessed by a general purpose or special purpose computer, including the functional design of any special purpose processor. By way of example, and not limitation, such non-transitory computer-readable media can include flash memory, RAM, ROM, EEPROM, CD-ROM or other optical disk storage, magnetic disk storage or other magnetic storage devices, or any other medium which can be used to carry or store desired program code means in the form of computer-executable instructions, data structures, or processor chip design. The computer readable media does not include carrier waves and electronic signals passing wirelessly or over wired connections.

Computer-executable instructions include, for example, instructions and data which cause a general purpose computer, special purpose computer, or special purpose processing device to perform a certain function or group of functions. Computer-executable

instructions also include program modules that are executed by computers in stand-alone or network environments. Generally, program modules include routines, programs, components, data structures, objects, and the functions inherent in the design of special-purpose processors, etc. that perform particular tasks or implement particular abstract data types. Computer-executable instructions, associated data structures, and program modules represent examples of the program code means for executing steps of the methods disclosed herein. The particular sequence of such executable instructions or associated data structures represents examples of corresponding acts for implementing the functions described in such steps.

10

Processors suitable for the execution of a computer program include, by way of example, both general and special purpose microprocessors, and any one or more processors of any kind of digital computer. Generally, a processor will receive instructions and data from a read-only memory or a random access memory or both. The essential elements of a computer are a processor for performing or executing instructions and one or more memory devices for storing instructions and data. Generally, a computer will also include, or be operatively coupled to receive data from or transfer data to, or both, one or more mass storage devices for storing data, e.g., magnetic, magneto-optical disks, or optical disks.

15
20

In this specification, the term “software” is meant to include firmware residing in read-only memory or applications stored in magnetic storage or flash storage, for example, a solid-state drive, which can be read into memory for processing by a processor. Also, in some implementations, multiple software technologies can be implemented as sub-parts of a larger program while remaining distinct software technologies. In some implementations, multiple software technologies can also be implemented as separate programs. Finally, any combination of separate programs that together implement a software technology described here is within the scope of the subject technology. In some implementations, the software programs, when installed to operate on one or more electronic systems, define one or more specific machine implementations that execute and perform the operations of the software programs.

A computer program (also known as a program, software, software application, script, or code) can be written in any form of programming language, including compiled or interpreted languages, declarative or procedural languages, and it can be deployed in any form, including as a stand-alone program or as a module, component, subroutine, object, or other unit suitable for use in a computing environment. A computer program may, but need not, correspond to a file in a file system. A program can be stored in a portion of a file that holds other programs or data (e.g., one or more scripts stored in a markup language document), in a single file dedicated to the program in question, or in multiple coordinated files (e.g., files that store one or more modules, sub programs, or

portions of code). A computer program can be deployed to be executed on one computer or on multiple computers that are located at one site or distributed across multiple sites and interconnected by a communication network.

5 These functions described above can be implemented in digital electronic circuitry, in computer software, firmware or hardware. The techniques can be implemented using one or more computer program products. Programmable processors and computers can be included in or packaged as mobile devices. The processes and logic flows can be performed by one or more programmable processors and by one or more programmable
10 logic circuitry. General and special purpose computing devices and storage devices can be interconnected through communication networks.

 Some implementations include electronic components, for example microprocessors, storage and memory that store computer program instructions in a
15 machine-readable or computer-readable medium (alternatively referred to as computer-readable storage media, machine-readable media, or machine-readable storage media). Some examples of such computer-readable media include RAM, ROM, read-only compact discs (CD-ROM), recordable compact discs (CD-R), rewritable compact discs (CD-RW), read-only digital versatile discs (e.g., DVD-ROM, dual-layer DVD-ROM), a variety of
20 recordable/rewritable DVDs (e.g., DVD-RAM, DVD-RW, DVD+RW, etc.), flash memory (e.g., SD cards, mini-SD cards, micro-SD cards, etc.), magnetic or solid state hard drives,

read-only and recordable Blu-Ray[®] discs, ultra density optical discs, any other optical or magnetic media, and floppy disks. The computer-readable media can store a computer program that is executable by at least one processing unit and includes sets of instructions for performing various operations. Examples of computer programs or computer code include machine code, for example is produced by a compiler, and files including higher-level code that are executed by a computer, an electronic component, or a microprocessor using an interpreter.

While the above discussion primarily refers to controllers or processors that may execute software, some implementations are performed by one or more integrated circuits, for example application specific integrated circuits (ASICs) or field programmable gate arrays (FPGAs). In some implementations, such integrated circuits execute instructions that are stored on the circuit itself.

As used in this specification and any claims of this application, the terms “computer readable medium” and “computer readable media” are entirely restricted to tangible, physical objects that store information in a form that is readable by a computer. These terms exclude any wireless signals, wired download signals, and any other ephemeral signals.

20

CONCLUSION

A system and method has been shown in the above embodiments for the effective implementation of augmented windows. While various preferred embodiments have been shown and described, it will be understood that there is no intent to limit the invention by such disclosure, but rather, it is intended to cover all modifications falling within the spirit and scope of the invention, as defined in the appended claims. For example, the present invention should not be limited by software/program, computing environment, or specific hardware.

CLAIMS

1. An augmented window system implemented in a capsule traversing an evacuated tube transportation (ETT) structure, the augmented window system comprising:

a display;

5 a tracking camera tracking location of a passenger within the capsule, the passenger located proximate to the display;

a computer:

receiving a first location of the passenger within the capsule and rendering, on the display, a first perspective to the passenger

10 corresponding to the first location;

receiving a second location of the passenger within the capsule and rendering, on the display, a second perspective corresponding to the second location, the second perspective different than the first perspective;

15 wherein the first and second perspectives are derived from pre-recorded video data.

2. The augmented window system of claim 1, wherein tracking location of a passenger comprises tracking head position and orientation of the passenger.

20 3. The augmented window system of claim 1, wherein additional perspectives are continuously computed each time the user moves to a different location within the capsule

and, when the user is proximate to the display, such additional perspectives are derived from pre-recorded video data in real-time and displayed in the display.

4. The augmented window system as per claim 1, wherein the pre-recorded video data
5 comprises pre-recorded stereoscopic 3D data.
5. The augmented window system as per claim 4, wherein the first perspective and second perspective are computed using a 3D real-time renderer.
- 10 6. The augmented window system as per claim 1, wherein the tracking camera is in front of the passenger.
7. The augmented window system as per claim 1, wherein the tracking camera is part of the display.
- 15 8. The augmented window system as per claim 1, wherein the tracking camera tracks location using any of the following: face tracking or eye tracking.
9. The augmented window system as per claim 1, wherein the rendered first and second
20 perspectives additionally include an advertisement.

10. The augmented window system as per claim 1, wherein video playback in the display is coupled to a speed of the capsule.

11. A method as implemented in an augmented window implemented within a capsule
5 traversing an evacuated tube transportation (ETT) structure, the method comprising:

receiving, from a tracking camera located with the capsule, a first location of a passenger within the capsule and rendering, on a display within the capsule, a first perspective to the passenger corresponding to the first location, the passenger located proximate to the display;

10 receiving, from the tracking camera located with the capsule, a second location of the passenger within the capsule and rendering, on the display, a second perspective corresponding to the second location, the second perspective different than the first perspective; and

wherein the first and second perspectives are derived from pre-recorded video data.

12. The method as per claim 11, wherein the tracking camera locates the passenger by tracking the passenger's head position and orientation.

13. The method as per claim 11, wherein additional perspectives are continuously
20 computed each time the user moves to a different location within the capsule and, when

the user is proximate to the display, such additional perspectives are derived from pre-recorded video data in real-time and displayed in the display.

14. The method as per claim 11, wherein the pre-recorded video data comprises pre-recorded stereoscopic 3D data.

15. The method as per claim 14, wherein the first perspective and second perspective are computed using a 3D real-time renderer.

16. The method as per claim 11, wherein the tracking camera is in front of the passenger.

17. The method as per claim 11, wherein the tracking camera is part of the display.

18. The method as per claim 11, wherein the tracking camera tracks location using any of the following: face tracking or eye tracking.

19. The method as per claim 11, wherein the rendered first and second perspectives additionally include an advertisement.

20. The method as per claim 11, wherein video playback in the display is coupled to a speed of the capsule.

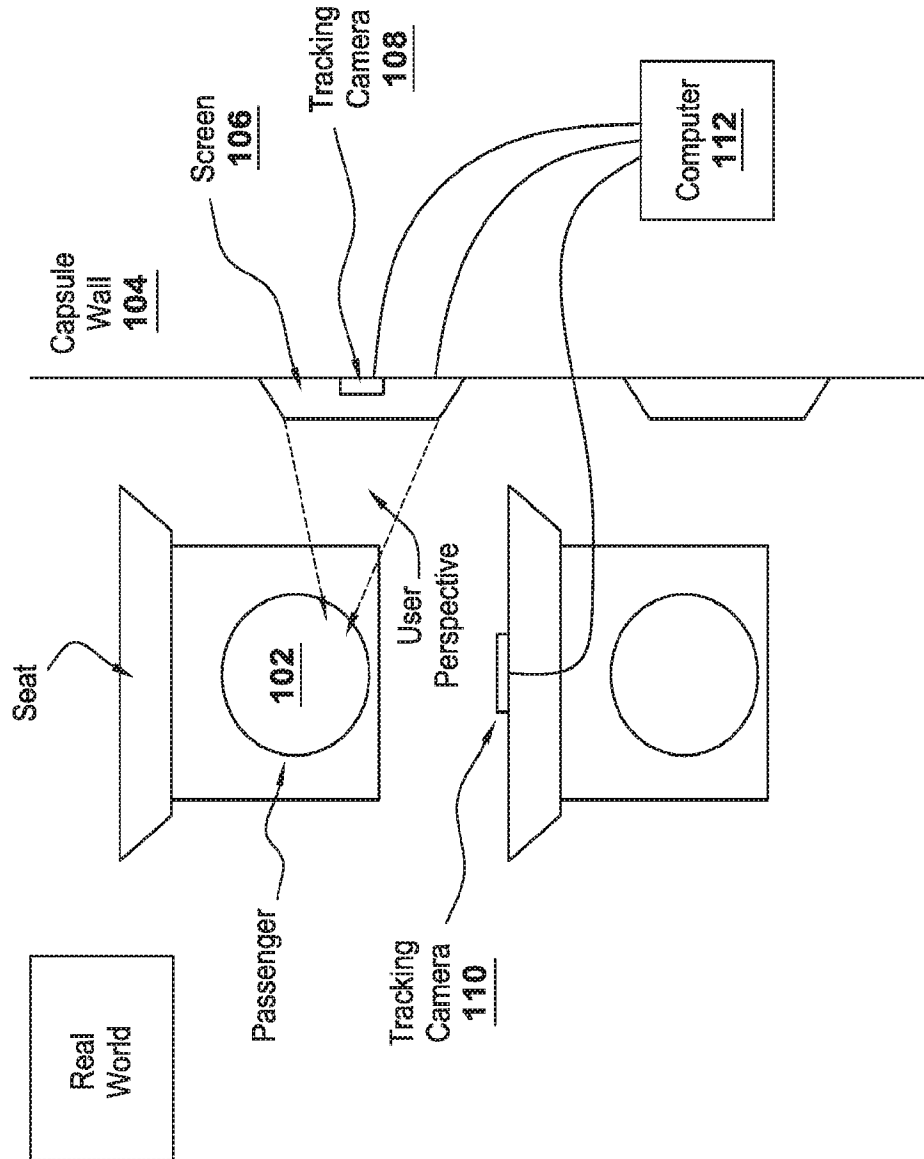

FIG. 1

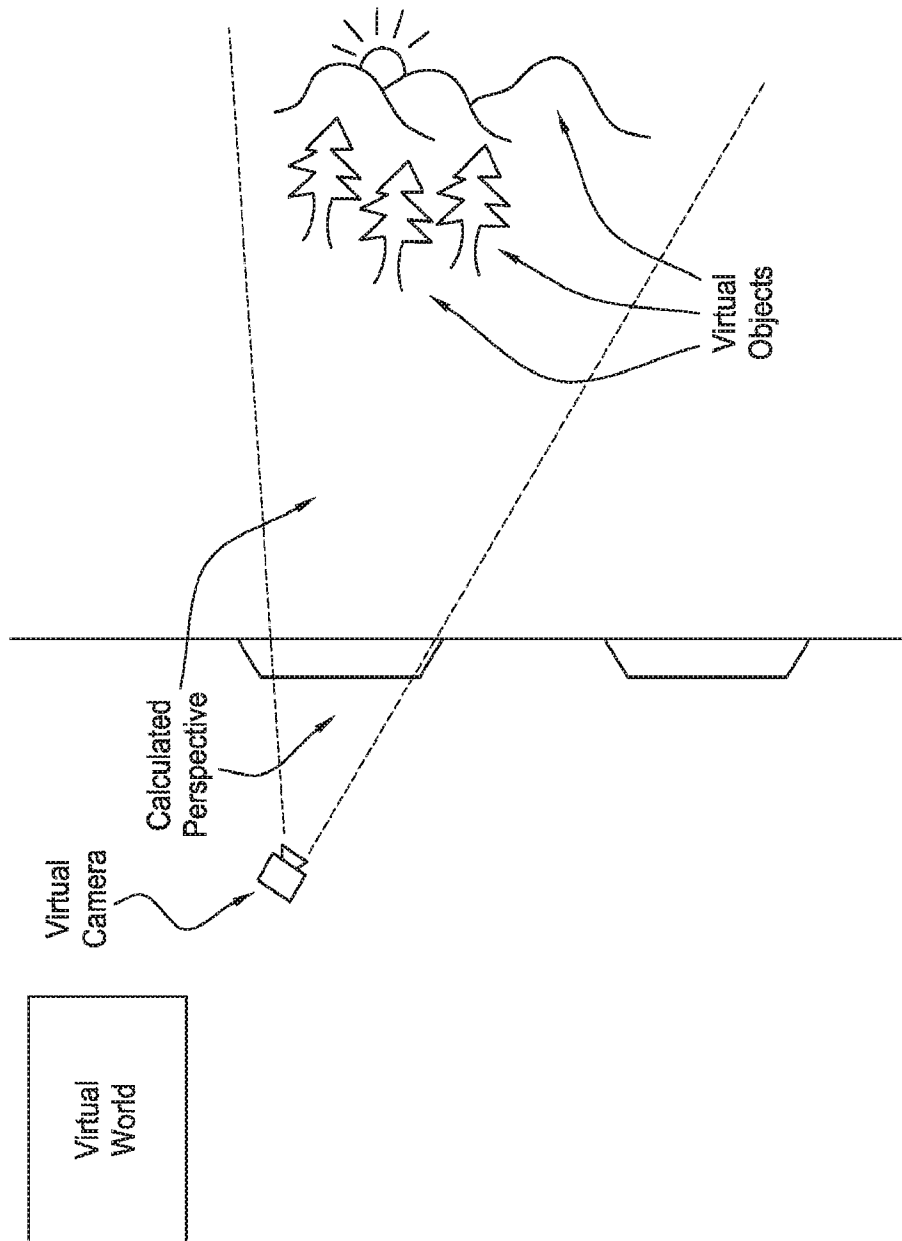

FIG. 2

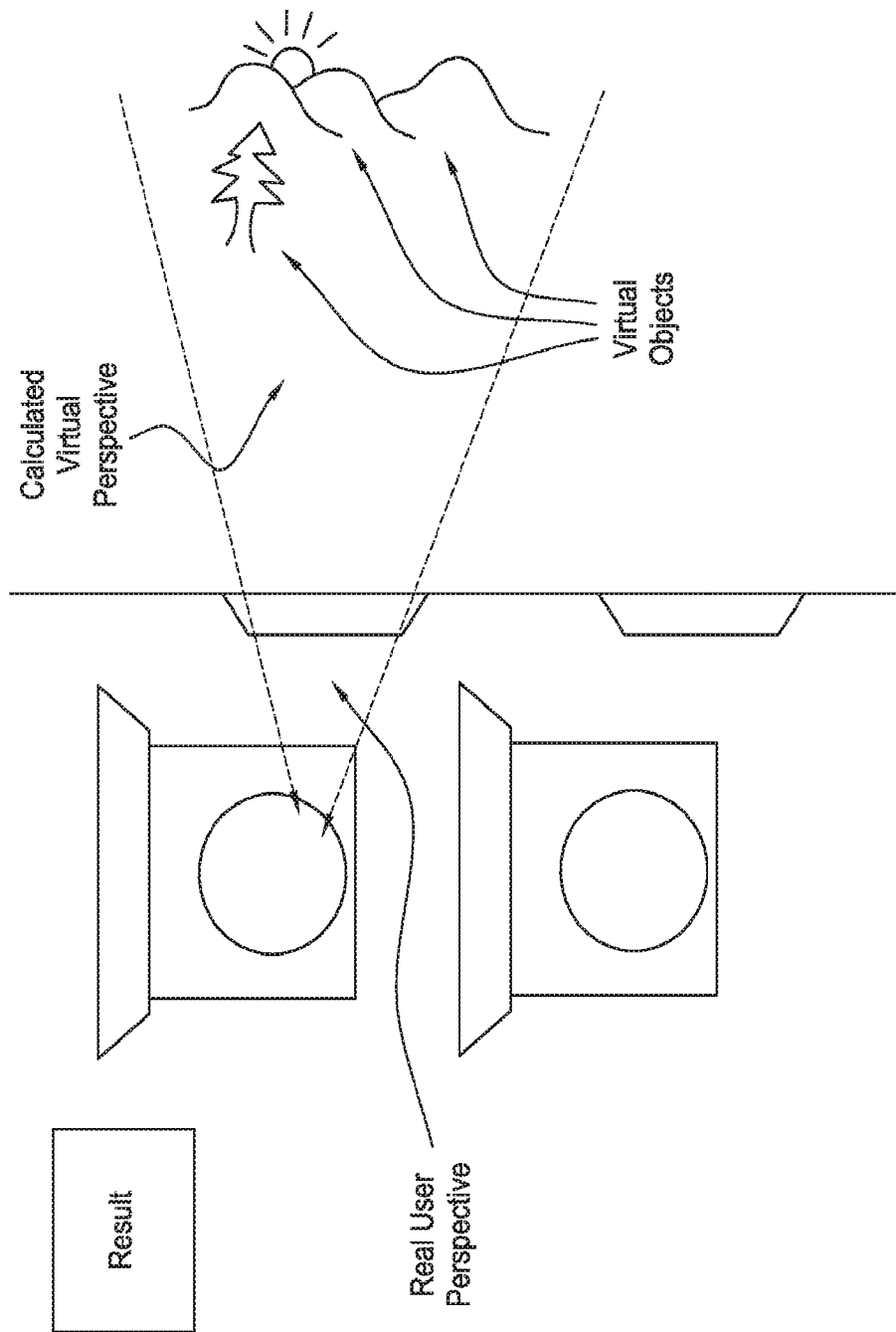

FIG. 3

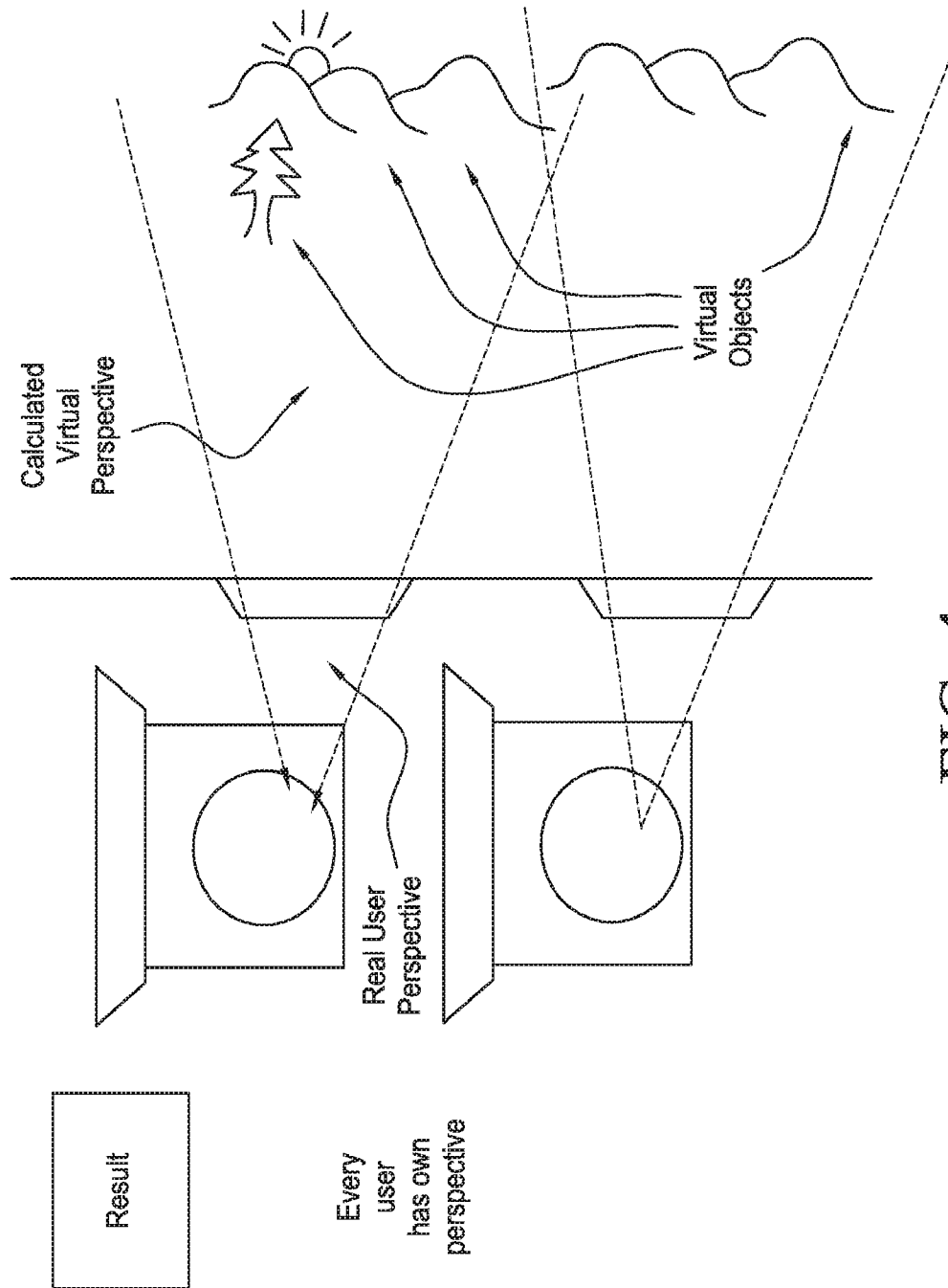

FIG. 4

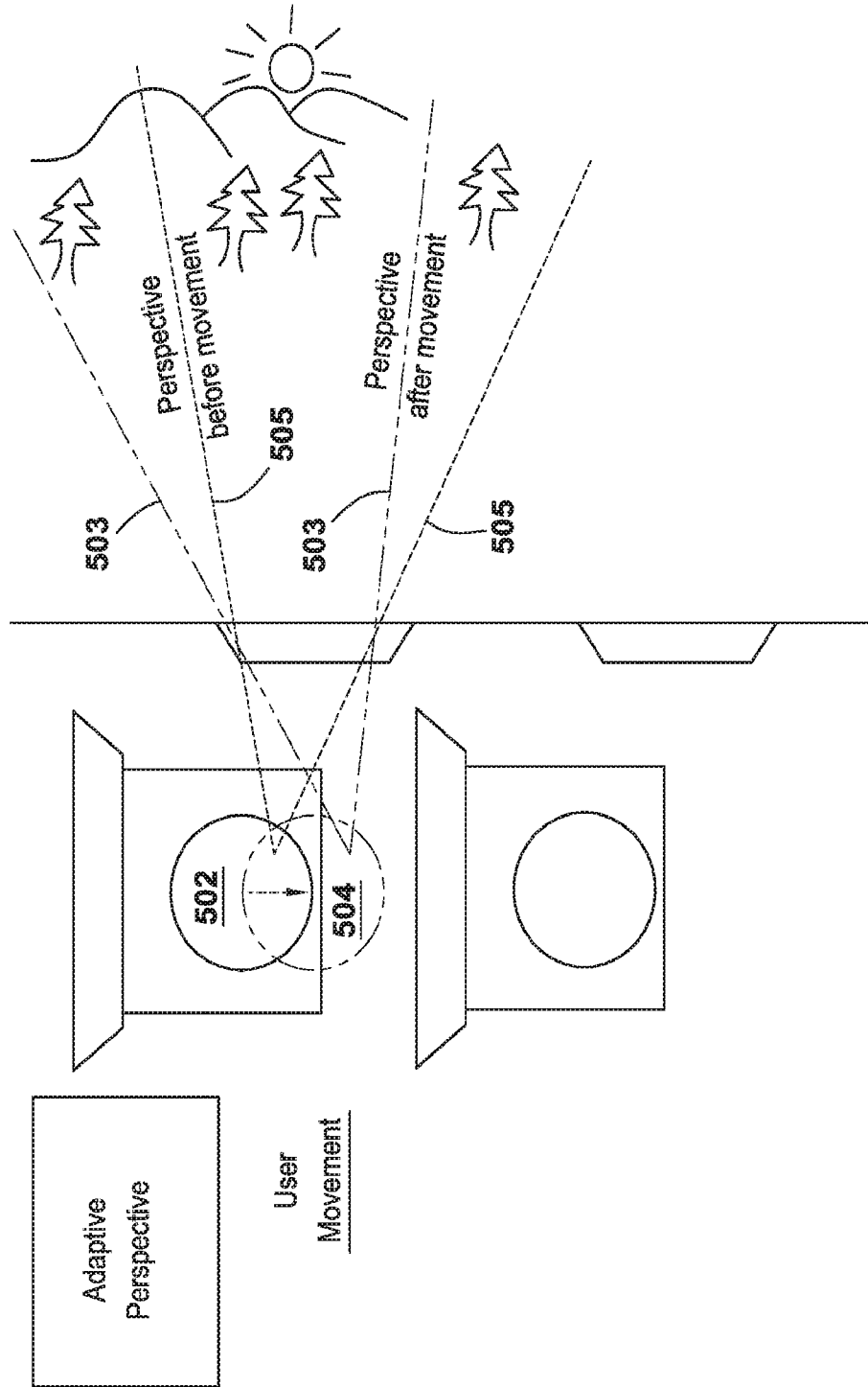

FIG. 5

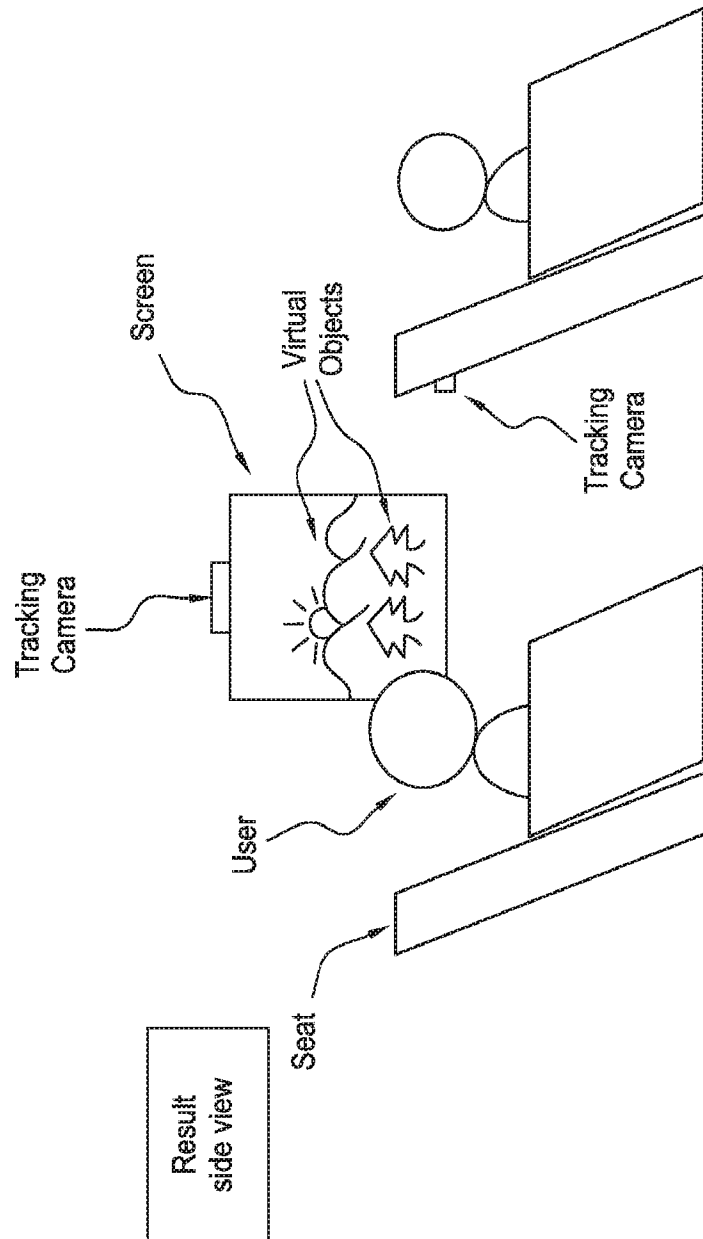

FIG. 6

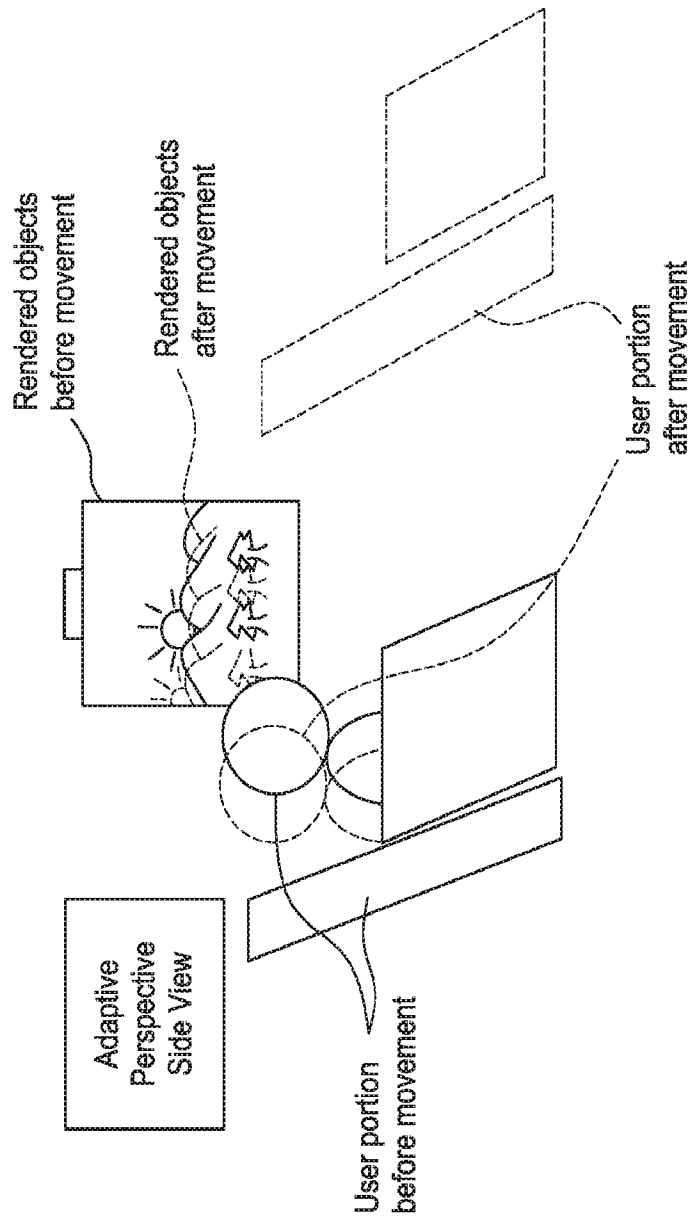

FIG. 7

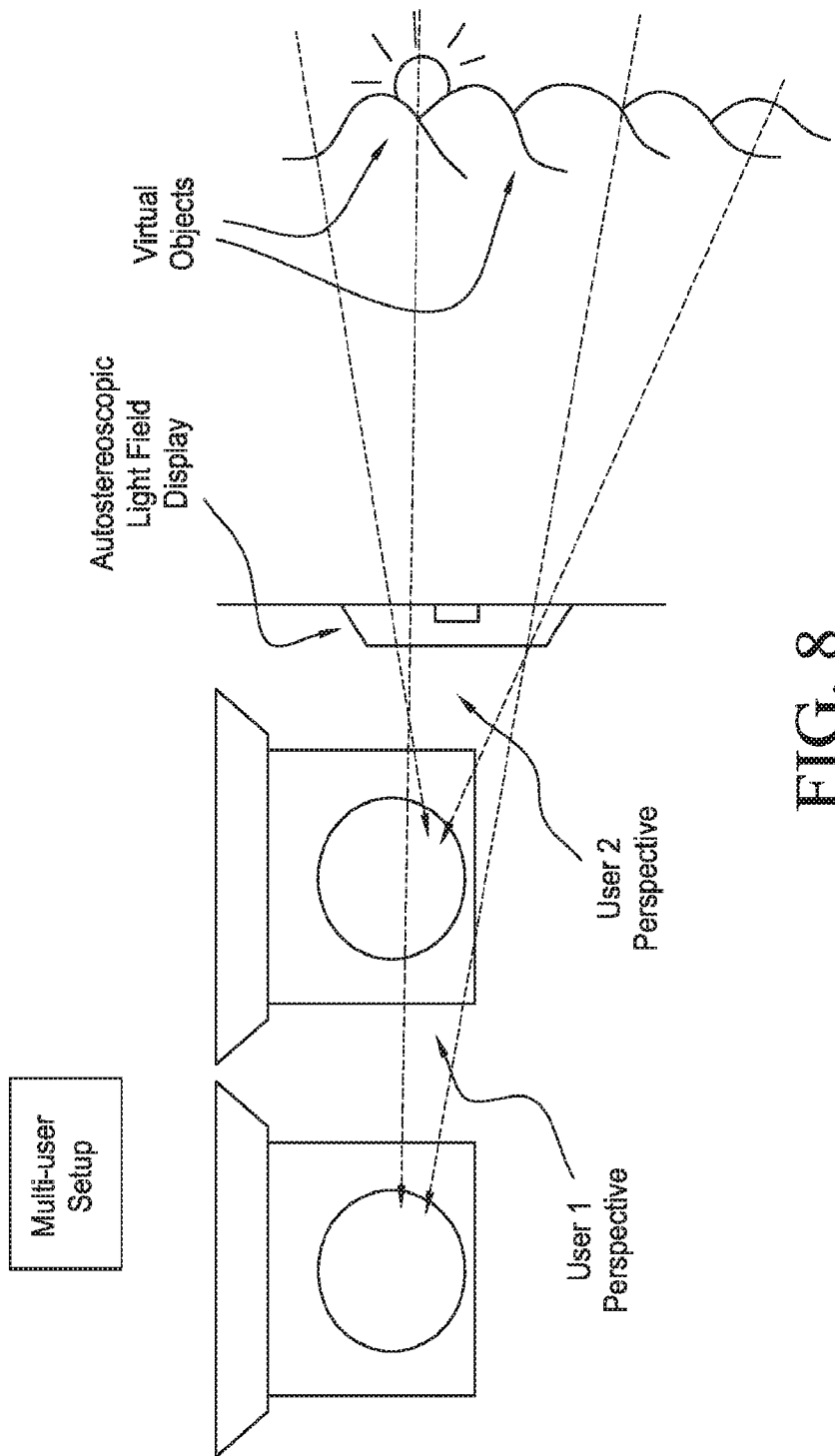

FIG. 8

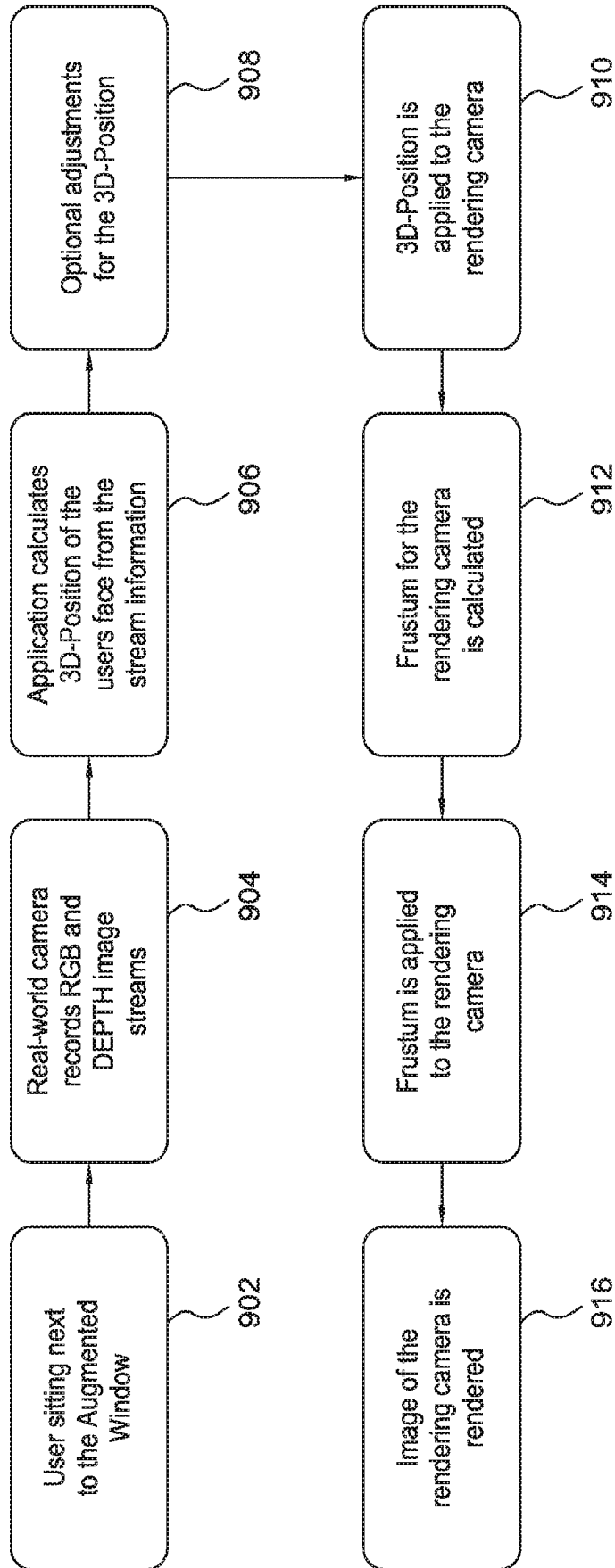

FIG. 9

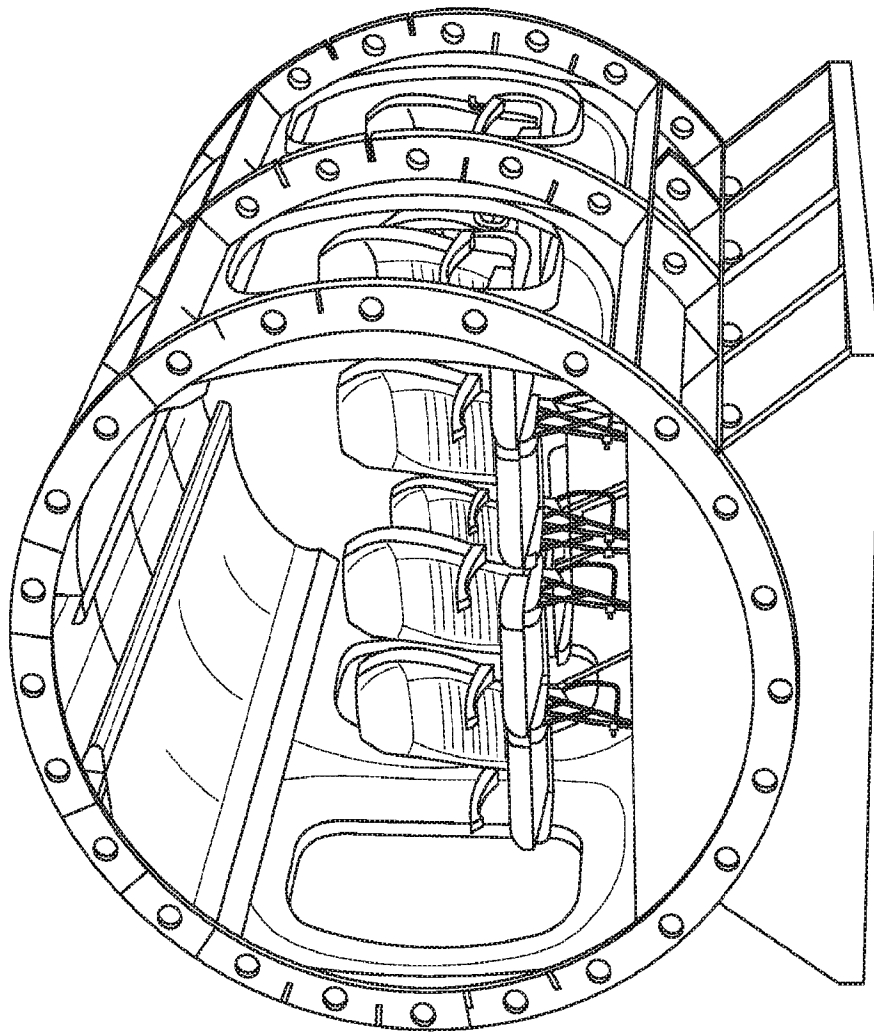

FIG. 10

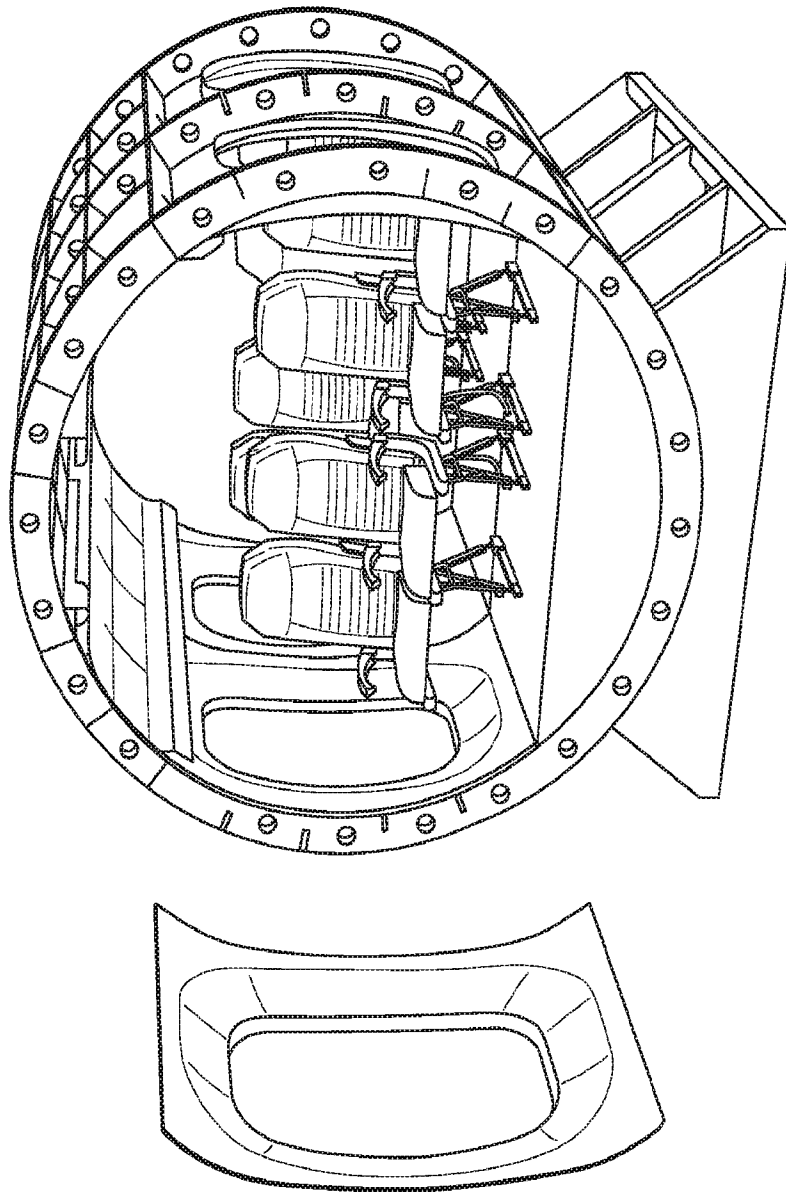

FIG. 11

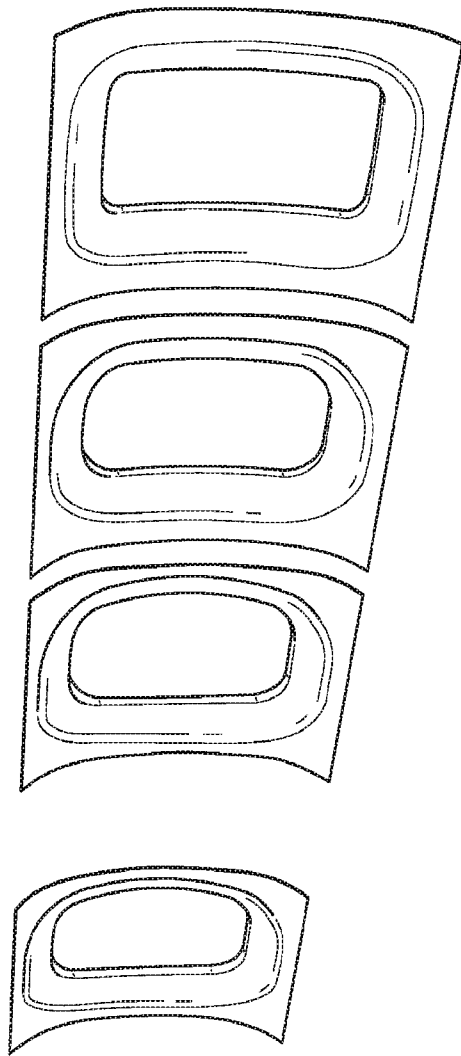

FIG. 12

INTERNATIONAL SEARCH REPORT

International application No.

PCT/US 17/21818

A. CLASSIFICATION OF SUBJECT MATTER

IPC(8) - B61B 13/00, G09G 5/00 (2017.01)

CPC - G06T19/006, G06T19/00, G06F3/011, G02B27/017, G06F3/012, Y02T30/30, B61B13/122, B65G51/02, B61B13/10, B61B13/00, B61B13/10, B61B13/122, B61B13/08, Y02T30/30, B60L2200/26

According to International Patent Classification (IPC) or to both national classification and IPC

B. FIELDS SEARCHED

Minimum documentation searched (classification system followed by classification symbols)

See Search History Document

Documentation searched other than minimum documentation to the extent that such documents are included in the fields searched

See Search History Document

Electronic data base consulted during the international search (name of data base and, where practicable, search terms used)

See Search History Document

C. DOCUMENTS CONSIDERED TO BE RELEVANT

Category*	Citation of document, with indication, where appropriate, of the relevant passages	Relevant to claim No.
Y	US 5,950,543 A (OSTER) 14 September 1999 (14.09.1999), col. 12, ln 18-25, col. 16, ln 28-52, col. 20, ln 53-67, col. 29, ln 31-41, col. 30, ln 24-56, col. 31, ln 46 - col. 32, ln 6, Fig. 3, Fig. 4.	1-20
Y	US 2016/0026253 A1 (BRADSKI et al.) 28 January 2016 (28.01.2016), entire document, especially abstract and para [0698], [0808], [0946], [0954]-[0955], [1466], [1519]-[1522].	1-20

 Further documents are listed in the continuation of Box C.

 See patent family annex.

* Special categories of cited documents:

"A" document defining the general state of the art which is not considered to be of particular relevance

"E" earlier application or patent but published on or after the international filing date

"L" document which may throw doubts on priority claim(s) or which is cited to establish the publication date of another citation or other special reason (as specified)

"O" document referring to an oral disclosure, use, exhibition or other means

"P" document published prior to the international filing date but later than the priority date claimed

"T" later document published after the international filing date or priority date and not in conflict with the application but cited to understand the principle or theory underlying the invention

"X" document of particular relevance; the claimed invention cannot be considered novel or cannot be considered to involve an inventive step when the document is taken alone

"Y" document of particular relevance; the claimed invention cannot be considered to involve an inventive step when the document is combined with one or more other such documents, such combination being obvious to a person skilled in the art

"&" document member of the same patent family

Date of the actual completion of the international search

26 May 2017 (26.05.2017)

Date of mailing of the international search report

20 JUN 2017

Name and mailing address of the ISA/US

Mail Stop PCT, Attn: ISA/US, Commissioner for Patents
P.O. Box 1450, Alexandria, Virginia 22313-1450

Facsimile No. 571-273-8300

Authorized officer:

Lee W. Young

PCT Helpdesk: 571-272-4300
PCT OSP: 571-272-7774