

(19) World Intellectual Property Organization
International Bureau



(43) International Publication Date
26 May 2006 (26.05.2006)

PCT

(10) International Publication Number
WO 2006/055174 A2

(51) International Patent Classification:
A61M 29/00 (2006.01)

(21) International Application Number:
PCT/US2005/037922

(22) International Filing Date: 20 October 2005 (20.10.2005)

(25) Filing Language: English

(26) Publication Language: English

(30) Priority Data:
10/986,714 12 November 2004 (12.11.2004) US

(71) Applicant (for all designated States except US): **C. R. BARD, INC.** [US/US]; 730 Central Avenue, Murray Hill, NJ 07974 (US).

(72) Inventors; and

(75) Inventors/Applicants (for US only): **TESSMER, Alexander, W.** [US/US]; 4226 N. 43rd Street, Phoenix, AZ 85018 (US). **SILKA, David, G.** [US/US]; 2537 East Cortez Street, Phoenix, AZ 85028 (US). **RAUCH, David, W.** [US/US]; 24 Abiquiu Court, San Dia Park, NM (US). **CHANDUSZKO, Andrzej, Jerzy** [US/US]; 311 North Carriage Lane, Chandler, AZ (US). **CARR, Robert, Michael, Jr.** [US/US]; 1001 North 55th Street, Paradise Valley, AZ (US).

(74) Agents: **WIGHT, Todd, W.** et al.; Morrison & Foerster LLP, 19900 MacArthur Boulevard, Irvine, CA 92612-2445 (US).

(81) Designated States (unless otherwise indicated, for every kind of national protection available): AE, AG, AL, AM, AT, AU, AZ, BA, BB, BG, BR, BW, BY, BZ, CA, CH, CN, CO, CR, CU, CZ, DE, DK, DM, DZ, EC, EE, EG, ES, FI, GB, GD, GE, GH, GM, HR, HU, ID, IL, IN, IS, JP, KE, KG, KM, KP, KR, KZ, LC, LK, LR, LS, LT, LU, LV, LY, MA, MD, MG, MK, MN, MW, MX, MZ, NA, NG, NI, NO, NZ, OM, PG, PH, PL, PT, RO, RU, SC, SD, SE, SG, SK, SL, SM, SY, TJ, TM, TN, TR, TT, TZ, UA, UG, US, UZ, VC, VN, YU, ZA, ZM, ZW.

(84) Designated States (unless otherwise indicated, for every kind of regional protection available): ARIPO (BW, GH, GM, KE, LS, MW, MZ, NA, SD, SL, SZ, TZ, UG, ZM, ZW), Eurasian (AM, AZ, BY, KG, KZ, MD, RU, TJ, TM), European (AT, BE, BG, CH, CY, CZ, DE, DK, EE, ES, FI, FR, GB, GR, HU, IE, IS, IT, LT, LU, LV, MC, NL, PL, PT, RO, SE, SI, SK, TR), OAPI (BF, BJ, CF, CG, CI, CM, GA, GN, GQ, GW, ML, MR, NE, SN, TD, TG).

Published:

— without international search report and to be republished upon receipt of that report

For two-letter codes and other abbreviations, refer to the "Guidance Notes on Codes and Abbreviations" appearing at the beginning of each regular issue of the PCT Gazette.

(54) Title: FILTER DELIVERY SYSTEM

(57) Abstract: A filter delivery device for implanting a vessel filter within a blood vessel of a patient's body. The filter delivery device includes a mechanism for preventing hooks and/or legs on a vessel filter from entangling with each other while the vessel filter is loaded within the delivery device. In one variation, the filter delivery device includes a delivery catheter with grooves at the distal end lumen opening. When a vessel filter with radially expanding legs is compressed and inserted into the distal end of the delivery catheter, the hooks on the distal end of the legs are received and separated by the corresponding grooves on the delivery catheter. In another variation, a pusher rod, with a receptacle for receiving the hooks, is positioned within a delivery catheter to prevent the entanglement of the hooks and/or legs of a filter loaded within the delivery catheter.

WO 2006/055174 A2

FILTER DELIVERY SYSTEM

[0001] This application claims priority to US application number 10/986,714, filed November 12, 2004, which is incorporated by reference herein.

BACKGROUND OF THE INVENTION

[0002] A vessel filter is a device inserted into a blood vessel to capture particles in the blood flow. Typically the device is inserted into a major vein to prevent a blood clot from reaching the lungs. Patients, who have recently suffered from trauma, have experienced a heart attack (myocardial infarction), or who have undergone major surgical procedure (*e.g.*, surgical repair of a fractured hip, etc.) may have thrombosis in a deep vein. When the thrombus clot loosens from the site of formation and travels to the lung it may cause pulmonary embolism, a life-threatening condition. A vessel filter may be placed in the circulatory system to intercept the thrombi and prevent them from entering the lungs.

[0003] Examples of various blood vessel filters and delivery systems are disclosed in U.S. Patent Application, Publication No. 2001/0000799 A1, titled "BODY VESSEL FILTER" by Wessman *et al.*, published May 3, 2001; U.S. Patent Application, Publication No. 2002/0038097 A1, titled "ATRAUMATIC ANCHORING AND DISENGAGEMENT MECHANISM FOR PERMANENT IMPLANT DEVICE" by Ostrovsky *et al.*, published September 26, 2002; U.S. Patent Application, Publication No. 2002/0193828 A1, titled "ENDOVASCULAR FILTER" by Griffin *et al.*, published December 19, 2002; U.S. Patent Application, Publication No. 2003/0199918 A1, titled "CONVERTIBLE BLOOD CLOT FILTER" by Patel *et al.*, published October 23, 2003; U.S. Patent Application, Publication No. 2003/0208227 A1, titled "TEMPORARY VASCULAR FILTERS AND METHODS" by Thomas, published November 6, 2003; U.S. Patent Application, Publication No. 2003/0208253 A1, titled "BLOOD CLOT FILTER" by Beyer *et al.*, published Nov. 6, 2003; U.S. Patent Application No. 2004/0082966 A1, by WasDyke, published Apr. 29, 2004; U.S. Patent No. 4,425,908, titled "BLOOD CLOT FILTER" issued to Simon, dated January 17, 1984; U.S. Patent No. 4,643,184, titled "EMBOLUS TRAP" issued to Mobin-Uddin, dated February 17, 1987; U.S. Patent No. 4,817,600, titled "IMPLANTABLE FILTER" issued to Herms *et al.*, dated April 4, 1989; U.S. Patent No. 5,059,205, titled "PERCUTANEOUS ANTI-MIGRATION VENA CAVA FILTER" issued to El-Nounou *et al.*, dated Oct. 22, 1991; U.S. Patent No. 5,147,379, entitled "INSERTION INSTRUMENT FOR VENA CAVA FILTER" issued to Sabbaghian *et al.*, dated Sep. 15,

1992; U.S. Patent No. 5,626,605, entitled "THROMBOSIS FILTER" issued to Irie *et al.*, dated May 6, 1997; U.S. Patent No. 5,634,942, titled "ASSEMBLY COMPRISING A BLOOD FILTER FOR TEMPORARY OR DEFINITIVE USE AND A DEVICE FOR IMPLANTING IT" issued to Chevillon *et al.*, dated Jun. 3, 1997; U.S. Patent No. 5,755,790, titled "INTRALUMINAL MEDICAL DEVICE" issued to Chevillon *et al.*, dated May 26, 1998; U.S. Patent No. 5,853,420, titled "ASSEMBLY COMPRISING A BLOOD FILTER FOR TEMPORARY OR DEFINITIVE USE AND A DEVICE FOR IMPLANTING IT, CORRESPONDING FILTER AND METHOD OF IMPLANTING SUCH A FILTER" issued to Chevillon *et al.*, dated Dec. 29, 1998; U.S. Patent No. 6,258,026 B1, titled "REMOVABLE EMBOLUS BLOOD CLOT FILTER AND FILTER DELIVERY UNIT" issued to Ravenscroft *et al.*, dated July 10, 2001; U.S. Patent No. 6,342,062 B1, titled "RETRIEVAL DEVICES FOR VENA CAVA FILTER" issued to Suon *et al.*, dated Jan. 29, 2002; U.S. Patent No. 6,383,193 B1, titled "VENA CAVA DELIVERY SYSTEM" issued to Cathcart *et al.*, dated May 7, 2002; U.S. Patent No. 6,497,709 B1, titled "METAL MEDICAL DEVICE" issued to Heath, dated December 24, 2002; U.S. Patent No. 6,506,205 B2, titled "BLOOD CLOT FILTERING SYSTEM" issued to Goldberg *et al.*, dated January 14, 2003; and U.S. Patent No. 6,517,559 B1, titled "BLOOD FILTER AND METHOD FOR TREATING VASCULAR DISEASE" issued to O'Connell, dated February 11, 2003; U.S. Patent No. 6,540,767 B1, titled "RECOILABLE THROMBOSIS FILTERING DEVICE AND METHOD" issued to Walak *et al.*, dated April 1, 2003; U.S. Patent No. 6,620,183 B2, titled "THROMBUS FILTER WITH BREAK-AWAY ANCHOR MEMBERS" issued to DiMatteo, dated September 16, 2003; each of which is incorporated herein by reference in its entirety.

[0004] Typically, the filter comprises a plurality of radially expandable legs that support one or more filter baskets having a conical configuration. The device is configured for compression into a small size to facilitate delivery into a vascular passageway and is subsequently expandable into contact with the inner wall of the vessel. The device may later be retrieved from the deployed site by compressing the radially expanded legs and the associated baskets back into a small size for retrieval. The radially expandable leg may further comprise engagements for anchoring the filter in position within a blood vessel (*e.g.*, vena cava). For example, the expandable legs may have hooks that can penetrate into the vessel wall and positively prevent migration of the filter in either direction along the length of the vessel. The body of the filter may comprise various biocompatible materials including compressible spring metals and shape memory materials to allow easy expansion

and compression of the filter within the vessel. The hooks on the radially expandable legs may further comprise materials more elastic than the legs to permit the hooks to straighten in response to withdrawal forces to facilitate withdrawal from the endothelium layer without risk of significant injury to the vessel wall. The hooks may be formed on selected radially expandable legs, but not on others.

[0005] Many of the existing vena cava filters routinely encounter problems during deployment due to entanglements of the radially expandable legs. This is especially problematic in designs with hooks implemented on the radially expandable legs. In the compressed/collapsed condition, the various hooks on the legs may interlock with other legs or hooks and render the device useless. Thus, an improved vessel filter delivery device that can prevent entanglement and/or interlocking of the radially expandable legs when the filter is collapsed and placed inside the delivery device is desirable.

BRIEF SUMMARY OF THE INVENTION

[0006] Accordingly, described herein is a vessel filter delivery device with a built-in mechanism for preventing the hooks on the radially expandable legs from interlocking when the vessel filter is compressed and inserted into the lumen of a delivery catheter. The improved vessel filter delivery device may also prevent the radially expandable legs from becoming entangled. In one variation, the vessel filter delivery device comprises an elongated catheter configured with a plurality of grooves at the distal opening to separate the hooks on a vessel filter loaded in the lumen of the catheter. Preferably, each of the grooves has one end that opens at the distal tip of the catheter to allow the hooks to slide out without obstruction, and the proximal end of the groove is configured with a ledge to prevent the catheter from migrating toward the proximal end of the catheter, keeping the vessel filter at the proximal end of the catheter lumen. The ledge may be configured with a profile approximating the curvature of the hook to help maintain the shape of the hook while the vessel filter is loaded inside the delivery catheter. The profile on the ledge may also be configured to minimize fatigue of the material comprising the hook. This feature may be particularly useful for hooks comprised of a shape memory material. Furthermore, a pusher-wire with an attachment interface at the distal end for capturing the head or the sleeve of the vessel filter may be utilized for loading and unloading the vessel filter from the catheter.

[0007] In another variation, the vessel filter delivery device is configured with a mechanism for centering the delivery catheter prior to deploying the vessel filter. In one

example, the delivery catheter is configured with a plurality of flexible elements extending from the distal end of the catheter and flaring outward from the longitudinal axis of the catheter. When the delivery catheter is disposed within an introducer sheath, the wall of the introducer sheath compresses the plurality of wirings and allows the advancement of the catheter within the introducer sheath. As the introducer sheath is retracted from the distal end of the delivery catheter, the flexible elements protrude and expand from the distal opening of the sheath, and as a result, center the distal end of the catheter within the blood vessel. Centering of the delivery catheter may allow smoother deployment of the vessel filter, and also assist the legs of the vessel filter to expand evenly and center itself within the blood vessel. The deployment catheter with a centering mechanism may also be configured with grooves at the distal end of the lumen to prevent the hooks and legs of the vessel filter from entanglement.

[0008] In yet another variation, the vessel filter delivery device comprises a pusher-wire with an integrated receptacle for holding and separating the hooks on the legs of the vessel filter. The receptacle may prevent interlocking of the hooks and entanglement of the legs. The preloading of the hooks into the receptacle may also facilitate the loading of the vessel filter into the lumen of the catheter. In one example, the pusher device comprises an elongated wire with a pusher pad attached to the distal end thereof. An extension wiring connects a receptacle to the distal end of the pusher pad. The receptacle may be configured with a plurality of orifices. Each orifice is configured to receive a filter hook and/or its corresponding leg.

[0009] The improved vessel filter delivery device may provide one or more of the various advantages listed below: improved placement of the vessel filter in the delivery device; prevent loaded vessel filter from migrating towards the proximal end of the delivery device; minimization of fatigue of the vessel filter hooks while the vessel filter is loaded within the delivery device; improved deployability due to easier release of the radially expandable legs; improved deployment orientation and position of the vessel filter, which may result in improved trapping of significant emboli, good vessel patency, limited thrombogenic response at the implantation site, and a decrease in the risk of the hooks perforating the vessel wall.

[0010] These and other embodiments, features and advantages of the present invention will become more apparent to those skilled in the art when taken with reference to the following more detailed description of the invention in conjunction with the accompanying drawings that are first briefly described.

BRIEF DESCRIPTION OF THE DRAWINGS

[0011] FIG. 1 illustrates one variation of a delivery catheter comprising a catheter with grooves at the distal lumen for receiving the hooks at the distal end of the vessel filter.

[0012] FIG. 2 illustrates one variation of a vessel filter in an expanded position.

[0013] FIG. 3 illustrates an example of a vessel filter positioned within the delivery catheter for deployment. The hooks on the vessel filter are resting within the grooves that are cut into the cross-sectional area at the distal end of the delivery catheter. The delivery catheter is shown positioned within the lumen of an introducer sheath.

[0014] FIG. 4A is the frontal view of the vessel filter delivery system shown in FIG. 3, illustrating the distribution of the vessel filter legs within the lumen of the delivery catheter. The device is shown from the distal end of the delivery catheter down its longitudinal axis.

[0015] FIG. 4B is a cross-sectional view illustrating a hook of a vessel filter positioned within a groove in the delivery catheter. The catheter is shown sectioned along the length of the catheter.

[0016] FIG. 4C is a cross-sectional view of a delivery catheter illustrating one variation of a groove on the inner circumferential surface of a delivery catheter.

[0017] FIG. 4D is a sectional view illustrating the dimension of the grooves on another variation of the delivery catheter. The catheter is shown sectioned along the length of the catheter, with a vessel filter loaded in the lumen of the catheter.

[0018] FIG. 5A is a cross-sectional view illustrating one variation of a spline cap. The spline cap is configured for attachment to the distal end of a catheter to provide the hook receiving grooves.

[0019] FIG. 5B is a frontal view of the spline cap of FIG. 5A. The spline cap is shown from the distal end down its longitudinal axis.

[0020] FIG. 6A is a perspective view of another variation of a spline cap. In this design, the proximal portion of the spline cap is configured for insertion into the lumen of a catheter.

[0021] FIG. 6B is a cross-sectional view of the spline cap of FIG. 6A.

[0022] FIG. 6C is a frontal view of the spline cap of FIG. 6A. The spline cap is shown from the distal end down its longitudinal axis.

[0023] FIG. 6D illustrates an example of a filter delivery system with the spline cap of FIG. 6A implemented at the distal end of the delivery catheter. A vessel filter and a

pusher-wire are positioned within the lumen of the delivery catheter. The delivery catheter is slidably disposed within the lumen of an introducer sheath.

[0024] FIG. 6E is an expanded view of the distal portion of the filter delivery system shown in FIG. 6D, illustrating the placement of the vessel filter hooks within the grooves on the inner surface of the spline cap.

[0025] FIG. 6F is a perspective view of one variation of a safety cap. The safety cap is designed for placement over the distal end of a delivery catheter for securing the vessel filter loaded within the distal lumen of the delivery catheter during transport.

[0026] FIG. 6G is a cross-sectional view of the safety cap of FIG. 6F.

[0027] FIG. 6H illustrates one variation of an introducer sheath with its corresponding dilator position within its lumen. The introducer sheath and the dilator are interlocked as a unit for placement over a guidewire.

[0028] FIG. 6I illustrates the introducer sheath of FIG. 6H with the dilator removed, and a delivery catheter loaded with a vessel filter is inserted in the lumen of the introducer sheath. The distal portion of the delivery catheter is shown interlocked to the introducer sheath such that the dilator and the delivery catheter may be displaced within a blood vessel as a single unit when they are interlocked to each other.

[0029] FIG. 7A is a perspective view of another variation of a delivery catheter. In this variation, six wirings are provided at the distal end of the catheter to center the delivery catheter within a vessel.

[0030] FIG. 7B is a side view of the delivery catheter of FIG. 6A.

[0031] FIG. 7C illustrates a vessel filter positioned within the lumen of a delivery catheter with distal end centering wirings. The delivery catheter is shown positioned within the lumen of an introducer sheath.

[0032] FIG. 7D illustrates another variation of a centering mechanism comprising a plurality of loops connected to the distal end of the catheter.

[0033] FIG. 8A is a perspective view of another variation of a spline cap with six slots for receiving filter hooks, and six holes for the placement of centering wirings.

[0034] FIG. 8B is a perspective view of the spline cap of FIG. 8A, shown at a different angle.

[0035] FIG. 8C is a frontal view of the spline cap of FIG. 8A. The spline cap is shown from the distal end down its longitudinal axis.

[0036] FIG. 9A is a cross-sectional view of the spline cap of FIG. 8A.

[0037] FIG. 9B is a cross-sectional view of the spline cap of FIG. 9A, shown with the spline cap rotated 30 degree along its longitudinal axis.

[0038] FIG. 10A is a side view illustrating one variation of a pusher-wire having a deployment jig attached to the distal end of the pusher-wire. The deployment jig is configured for loading and unloading the vessel filter into the lumen of a deployment catheter.

[0039] FIG. 10B is a top view of the pusher-wire of FIG. 10A.

[0040] FIG. 10C is a perspective view of the pusher-wire of FIG. 10A.

[0041] FIG. 11 illustrates a pusher-wire extending from the lumen of a delivery catheter. The deployment jig located at the distal end of the pusher-wires captured the filter sleeve of a vessel filter. The vessel filter is shown in a compressed position.

[0042] FIG. 12 illustrates another variation of a pusher device. The pusher device comprises a receptacle attached to the pusher pad through a wire. The receptacle is configured with chambers to receive the hooks on the vessel filter.

[0043] FIG. 13 illustrates the pusher device of FIG. 12 placed within the lumen of a delivery catheter.

[0044] FIG. 14A illustrates the filter delivery system of FIG. 13 with a vessel filter loaded on the pusher device. The delivery catheter and its corresponding pusher device are placed within the lumen of an introducer sheath.

[0045] FIG. 14B illustrates the partial release of the vessel filter of FIG. 14A. The arms of the filter are shown in an expanded position, while the legs with their corresponding hooks are still secured by the receptacle on the pusher device.

[0046] FIG. 15A is a side view of one variation of a filter hook receptacle.

[0047] FIG. 15B is a prospective view of the filter hook receptacle of FIG. 15A.

[0048] FIG. 15C is a cross-sectional view of the filter hook receptacle of FIG. 15A.

[0049] FIG. 15D is a frontal view of the filter hook receptacle of FIG. 15A. The filter hook receptacle is shown from its proximal end down its longitudinal axis.

[0050] FIG. 16A is a prospective view of another variation of a filter hook receptacle.

[0051] FIG. 16B is a frontal view of the filter hook receptacle of FIG. 16A. The filter hook receptacle is shown from its proximal end down its longitudinal axis.

[0052] FIG. 17 illustrates another variation of a delivery catheter where a plurality of orifices are provided at the distal portion of the catheter for receiving and separating the hooks from a vessel filter inserted into the lumen of the catheter.

[0053] FIG. 18 illustrates another variation of a delivery catheter where a plurality of slots are provided at the distal end of the catheter for receiving and separating the hooks from a vessel filter inserted into the lumen of the catheter. As shown in FIG. 18, in this variation, the slots spanned across the thinness of the catheter wall.

[0054] FIG. 19 illustrates another variation of a vessel filter.

DETAILED DESCRIPTION OF THE INVENTION

[0055] The following detailed description should be read with reference to the drawings, in which identical reference numbers refer to like elements through out the different figures. The drawings, which are not necessarily to scale, depict selected embodiments and are not intended to limit the scope of the invention. The detailed description illustrates by way of example, not by way of limitation, the principles of the invention. This description will clearly enable one skilled in the art to make and use the invention, and describes several embodiments, adaptations, variations, alternatives and uses of the invention, including what is presently believed to be the best mode of carrying out the invention.

[0056] Before describing the present invention, it is to be understood that unless otherwise indicated, this invention need not be limited to applications in humans. As one of ordinary skill in the art would appreciate, variations of the invention may be applied to other mammals as well. Moreover, it should be understood that embodiments of the present invention may be applied in combination with various vessel filters, guidewires, catheters, tubing introducers or other filter deployment devices for implantation of a filter in a vessel within a patient's body.

[0057] A vena cava filter is used herein as an example application of the filter deployment device to illustrate the various aspects of the invention disclosed herein. In light of the disclosure herein, one of ordinary skill in the art would appreciate that variations of the filter deployment device may be applicable for placement of filters in various blood vessels, hollow body organs or elongated cavities in a human body. It is also contemplated that the vessel filter described herein may be implemented for capturing particles other than blood clots.

[0058] It must also be noted that, as used in this specification and the appended claims, the singular forms "a," "an" and "the" include plural referents unless the context clearly dictates otherwise. Thus, for example, the term "a hook" is intended to mean a single hook or a combination of hooks, "a fluid" is intended to mean one or more fluids, or a

mixture thereof. Furthermore, the words “proximal” and “distal” refer to directions closer to and away from, respectively, a physician operating the delivery catheter with the tip end (*i.e.*, distal end) placed inside the patient’s body. Thus, for example, the catheter end placed in the vena cava of the patient would be the distal end of the catheter, while the catheter end outside the patient’s body would be the proximal end of the catheter.

[0059] Referring to FIG. 1, a delivery catheter 2 configured for securing a vessel filter and placing the vessel filter to a desired location within a patient’s vascular system is illustrated. In this variation, the catheter 2 is configured with six grooves 4, 6, 8, 10, 12, 14, (*e.g.*, slots, notches, surface indentations, etc.) positioned on the inner surface 16 of the catheter 2 at the distal end 18 of the catheter. The six grooves 4, 6, 8, 10, 12, 14, are configured to receive six hooks 20, 22, 24, 26, 28, 30 on a corresponding vessel filter 32. The grooves 4, 6, 8, 10, 12, 14 are design to prevent the hooks 20, 22, 24, 26, 28, 30 and their corresponding legs 34, 36, 38, 40, 42, 44 from entangling with each other. In addition, because the grooves allow the hooks to remain in an expanded normal state while loaded in the catheter, the grooves may also minimize stress on the hooks. The delivery catheter may comprise a continuous piece of tubing with grooves etched into the distal end thereof. Alternatively, the delivery catheter may comprise elongated flexible tubing with a spline cap configured with grooves attached to the distal end of the tubing, as will be described in more detail below.

[0060] A vessel filter 32, such as the one shown in FIG. 2, may be compressed so that the expandable legs 34, 36, 38, 40, 42, 44 on the filter 32 collapse toward a longitudinal axis 46 of the vessel filter 32. The vessel filter 32 in the compressed state may be inserted into the distal end 18 of the delivery catheter 2 with the proximal end 48 (*i.e.*, the end with the sleeve 50) going into the lumen 52 of the catheter 2 first. The legs 34, 36, 38, 40, 42, 44 of the vessel filter 32 may be adjusted such that when the filter 32 is completely inserted into the delivery catheter 2, the hooks 20, 22, 24, 26, 28, 30 on the legs are placed within the corresponding grooves 4, 6, 8, 10, 12, 14 at the distal end 18 of the delivery catheter. Preferably, the grooves are configured to receive the hooks at the distal end of legs only, and not the length of the legs themselves. In an alternative design, the grooves may be configured with longer lengths and/or a deeper profiles such that they may accommodate at least part of the elongated portion of the legs. In addition to separating the hooks and thus their corresponding legs, the grooves may also prevent the filter from rotating within the lumen of the catheter.

[0061] In the particular variation of vessel filter shown in FIG. 2, the vessel filter 32 comprises two sets of legs 34, 36, 38, 40, 42, 44, and 54, 56, 58, 60, 62, 64 (*e.g.*, flexible or semi-flexible wiring, etc.) extending from a sleeve 50 in the radial direction towards the distal end 12 of the filter. The legs are configured with materials such that they may be collapsed toward a longitudinal axis 46 of the filter 32 for insertion into a delivery catheter 2. A first set of six legs 54, 56, 58, 60, 62, 64 when expanded, forms a first conical-shaped filter basket centered on the longitudinal axis 46 of the vessel filter 2. A second set of six legs 34, 36, 38, 40, 42, 44, when expanded, forms a second conical-shaped filter basket positioned distal to the first basket, which is also centered on the longitudinal axis 46 of the vessel filter 2. Hooks 20, 22, 24, 26, 28, 30 are provided at the distal ends of the second set of legs 34, 36, 38, 40, 42, 44 for anchoring the distal end of the second set of legs into the walls of the vessel.

[0062] Although in the filter example discussed above, the plurality of legs forms two filter baskets along the longitudinal length of the device, one may configure the device with only one filter basket, or alternatively with three or more filter baskets. In addition, the device may be configured with three or more legs forming each basket, and is not limited to the six-legged basket shown in FIG. 2. Also, as discussed above, barb feet (*e.g.*, hooks) may be provided on the distal end of each leg. As one of ordinary skill in the art would appreciate, the precise length and angle of the barb feet may be designed to provide secure attachment to the vessel wall without causing perforation or tearing. Moreover, hooks may be provided on all the distal legs or only on some of the distal legs. Hooks may also be provided on the proximal legs if desired. Furthermore, secondary struts may be provided for interconnecting two or more of the radially expandable legs. The secondary struts may increase wiring density for each filter basket, which may in turn increase the filters capability to capture smaller particles. In addition, the sleeve 50 may be comprised of a biocompatible metal, metal alloy, or polymeric material. The legs 34, 36, 38, 40, 42, 44, 54, 56, 58, 60, 62, 64 may be comprised of a metal (*e.g.*, stainless steel, titanium, etc.), metal alloy (*e.g.*, titanium alloy, Elgiloy, an alloy comprising Cobalt-Nickel-Chromium, etc.), shape memory material (*e.g.*, Nitinol, shape memory alloyed, shape memory polymer, etc.), or polymeric material (*e.g.*, biocompatible plastics, etc.).

[0063] Referring to FIG. 3, a vessel filter 32 is placed within a delivery catheter 2, which is slidably disposed in the lumen 66 of an introducer sheath 68. The vessel filter 32 is located within the distal portion of the catheter 2. The wall of the delivery catheter 2 prevents the legs 54, 60, 34, 40 of the vessel filter from expanding. The hooks 20, 26 rest in

their corresponding grooves 10, 4 at the distal end 18 of the delivery catheter 2. As shown in FIG. 3, an optional ledge 70 is provided in each of the grooves 10, 4. When the hook rests within the groove, the ledge blocks the hook from moving in the proximal direction. As a result, the vessel filter 32 can not migrate in the proximal direction (-Z) along the length of the catheter 2 lumen.

[0064] To deploy the vessel filter, a pusher-wire inserted inside the lumen of the delivery catheter proximal of the vessel filter may be utilized to unload the vessel filter. The pusher-wire may comprise a flexible wiring or a flexible rod with its distal end configured to contact the proximal end of the vessel filter. The pusher-wire may have a pusher pad attached to its distal end. To deploy the vessel filter, one would insert the introducer sheath into the circulatory system through methods well known to one of ordinary skill in the art. The introducer sheath provides a pathway for the physician to advance the delivery catheter loaded with the vessel filter to the desired deployment location. One may then advance the distal tip of the delivery catheter out the distal opening of the introducer sheath. With the distal tip of the pusher-wire positioned just proximal of the proximal end of the vessel filter, the physician may retract both the introducer sheath and the delivery catheter while simultaneously holding the pusher-wire in place to force the vessel filter out of the lumen of the delivery catheter. As the introducer sheath and the delivery catheter are displaced in the proximal direction (-Z) relative to the vessel filter, the filter is deployed into the blood vessel. As the filter slides out of the delivery catheter's lumen, the legs of the vessel filter expand and engage the wall of the blood vessel. Because the hooks are separated by their corresponding grooves, the hooks are prevented from interlocking with one another and a smooth deployment may be achieved.

[0065] In the variation shown in FIG. 4A, the vessel filter 32 is loaded within the lumen 52 of the delivery catheter 2, positioned such that the long legs 34, 36, 38, 40, 42, 44, having hooks at their distal ends aligned with the grooves 10, 8, 6, 4, 14, 12 of the delivery catheter 2, where each of the hooks rest within its corresponding groove. The short legs 54, 56, 58, 60, 62, 64 rest directly on the inner lumen wall of the delivery catheter 2. Although in this example six grooves are provided to support a filter with six hooks, one of ordinary skill in the art having the benefit of this disclosure would appreciate that other combination of grooves (*e.g.*, three, four, five, seven or more) may be implemented to accommodate various filter designs. In addition, one of ordinary skill in the art would appreciate that the grooves may be configured to be various other geometric shapes. The spacing of the groove

distribution around the lumen opening may also vary depending on the design of the vessel filter.

[0066] Furthermore, the groove may be configured to extend along the longitudinal axis of the catheter. In the example shown in FIG. 4B, the distal end 72 of the groove 74 is open to allow the hook 76 to easily slide out of the distal end 18 of the delivery catheter 2. The proximal end 78 of the groove 74 is configured with a ledge 80 which may interface with the hook and prevent the vessel filter from migrating in the proximal direction. It is preferable that the length of the groove "D2" along the longitudinal axis of the catheter is one-fourth of an inch or less; more preferably "D2" is one-eighth of an inch or less. Alternatively, one may design the length "D2" of the groove based on the length of the hook "D1" along the longitudinal axis of its corresponding leg. Preferably, "D2" is equal or less than ten times the length of "D1"; more preferably "D2" is equal or less than four times the length of "D1". In addition, it is preferable that the depth "D3" of the grooves is equal or less than 0.06 inches; more preferably, the depth "D3" of the groove is equal to or less than 0.04 inches. The groove may have a constant depth along the circumferential direction. Alternatively, the groove may be designed with varying depths along the circumferential direction. For example, the depth of the groove may be wider at the two edges, and narrower at the center, such that $D4 > D3$, as shown in FIG. 4C. In one particular variation, the groove is designed with a length $D2 = 0.1$ inches, the depth of the groove at the two edges $D4$ are 0.014 inches, while the depth of the groove at the center $D3$ is 0.013 inches, as shown in FIG. 4D. The particular vessel filter shown in FIG. 4D has a set of six identical hooks with each having a length $D1$ of about 0.025 inches.

[0067] Although in the above examples, each of the delivery catheters has a set of identical grooves, one of ordinary skill in the art having the benefit of this disclosure would appreciate that the delivery catheter may be designed with grooves of varying sizes. For example, the grooves may have varying lengths, widths and depths to accommodate the corresponding vessel filter to be inserted inside the lumen of the delivery catheter. In one variation, the length of the legs on the vessel filter may be varied such that the positions of the hooks are staggered along the longitudinal axis. The delivery catheter may be designed with grooves of varying lengths to accommodate this vessel filter with staggered hooks. In another variation, the vessel filter may have hooks of varying sizes. The delivery catheter may be designed with grooves of varying widths and depths to accommodate the variations in the dimensions of the hooks.

[0068] In another variation, the delivery catheter comprises a spline cap 82 attached to the distal end of a catheter. In one variation, as shown in FIG. 5A, the spline cap 82 comprises a piece of cylindrical metal with a lumen extending from the distal end to the proximal end 86. A plurality of grooves 88, 90, 92, 94, 96, 98 is placed on the inner circumferential surface at the distal end 84 of the spline cap 82 for receiving and separating the hooks on the vessel filter. In this example, the length of the spline cap "L1" is 0.24 inches; the length of the groove "L2" along the longitudinal axis of the spline cap is 0.04 inches. In this variation, a ledge is provided at the proximal end of the groove to prevent proximal migration of the loaded vessel filter. The proximal end of the spline cap is configured with a C-bore 100. The distal end of the catheter may be solvent-bond into the C-Bore 100 of the spline cap 2. The C-Bore has an inner radius "R1" of 0.114 inches. The grooves are evenly distributed in a circumferential manner around the lumen of the spline cap. As shown in FIG. 5B the grooves 88, 90, 92, 94, 96, 98 are displaced in 60 degree increments. The width of the groove "L3" is 0.02 inches; the inner diameter "R2" of the spline cap is 0.088 inches, the outer diameter "R3" of the spline cap is 0.124 inches, the depth of the groove "L4" is 0.012 inches. In one particular variation, the delivery catheter is designed to fit within an introducer sheath with a 10 French inner diameter. Such a delivery catheter may be constructed by attaching a spline cap having a low profile design, as described above, to the tip of a catheter of corresponding size.

[0069] In addition, in this example, the dimensions of the grooves are configured to accommodate the hooks but not the length of the elongated legs. However, one of ordinary skill in the art having the benefit of the disclosure herein would appreciate the dimension of the grooves may be modified to accommodate both the hooks and the corresponding legs that connects to the hooks. For example, the length of the grooves may be extended and the width widened to accommodate the legs. In addition, one may modify the depth of the grooves to accommodate the length of the legs. In one variation, each groove may be configured with two sections, a proximal section configured to accommodate at least part of the leg, and a distal section configured to receive the corresponding hook (*e.g.*, the distal section may be deeper than the proximal section). Although in the above example, the spline cap comprises a metallic material, one of ordinary skill in the art having the benefit of this disclosure would appreciate that the spline cap may comprise a polymeric material.

[0070] FIG. 6A illustrates another variation of a spline cap 102. In this variation, the proximal portion 104 of the spline cap 102 is configured for insertion into the lumen of a catheter to form a delivery catheter. Barbs 106, 108, 110, 112, 114, 116 and/or ribs may be

provided on the circumferential surface of the spline cap to improve contact between the spline cap 102 and the inner surface of the catheter. Adhesive may also be utilized to secure the spline cap in distal lumen of the catheter. In this example, as shown in FIG. 6B, the overall length "L5" of the spline cap is 0.4 inches; the length "L7" of each of the groove is 0.1 inches; the length "L8" of each of the barb is 0.04 inches; the outer diameter "R4" at the proximal end is 0.98 inches; the diameter "R5" at the edge of each of the barb is 0.104 inches. FIG. 6C is a frontal view of the spline cap 102 showing the six grooves 118, 120, 122, 124, 126, 128 evenly distributed around the lumen 130 in 60 degree increments. The outer diameter "R6" at the distal end 132 of the spline cap is 0.1235 inches, and the inner diameter "R7" is 0.088 inches. The spline cap 102 may be manufacture with sharp edges 134 on the barbs, such that the spline cap 102 may be embedded into the catheter and be securely maintained within the distal end of the catheter.

[0071] FIG. 6D illustrates a vessel filter 136 positioned within the lumen 138 of a delivery catheter 140 for deployment. As shown, both the legs 142 and the arms 144 of the vessel filter 136 are in a contracted position. In this example, the delivery catheter 140 comprises a catheter 146 with the spline cap 102 shown in FIG. 6A, inserted within the distal end 148 of the catheter 146. A pusher-wire 150 is also placed within the lumen 138 of the delivery catheter 140 immediately proximal to the sleeve 152 (*i.e.* head-end) of the vessel filter 136. The distal end of the pusher-wire has a pusher pad 154 to improve contact between the pusher-wire 150 and the vessel filter 136. The delivery catheter 140 is shown slidably positioned within the lumen of an introducer sheath 156. FIG. 6E is an expanded view illustrating the placement of the hooks 158 within the corresponding grooves 160 on the inner wall 162 of the spline cap 102. Each hook 158 is placed within one of the six grooves 160 that are distributed around the distal lumen opening 164.

[0072] FIG. 6F illustrates an optional cap 166 or cover for securing the vessel filter after the vessel filter has been loaded within the lumen of the delivery catheter. The cap is configured for placement over the distal end of the delivery catheter after the vessel filter has been inserted into the distal end of the delivery catheter. The lumen 168 of the cap 166 is wide enough to receive the distal portion of a delivery catheter. The inner base of the cap 166 may be configured with a protrusion 170 such that when the cap 166 is placed over the delivery catheter, the protrusion 170 may advance into the distal lumen of the delivery catheter. The protrusion 170 may engage the hooks to prevent the vessel filter from sliding and may also keep the hooks in their corresponding slot. In this example, the length "L10" of the cap" is 0.44 inches; the length "L12" of the inner protrusion is 0.06 inches; the width

“L11” is 0.28 inches; and the diameter “R8” at the proximal end is 0.19 inches. In one application, the vessel filter is loaded into the delivery catheter at the manufacturing site before it is delivered to the hospital for implantation into a patient. A safety cap 166, such as one shown in FIG. 6F may be placed over the distal end of the delivery catheter to keep the filter in place and prevent movement of the vessel filter during transport. When the surgeon is ready to implant the vessel filter, the surgeon may then remove the safety cap and insert the delivery catheter along with the loaded vessel filter into an introducer sheath that has been inserted into the patient’s blood vessel.

[0073] The vessel filter delivery device disclosed above may be utilized for implantation of a vessel filter into various hollow body organs throughout the human body. In a common application, the vessel filter delivery device is inserted into the jugular vein at the patient’s neck or the subclavian vein under the clavicle, for placement of a vessel filter at the inferior vena cava. For example, the implantable vessel filter is prepared by collapsing the legs of the filter and inserting the proximal end (*i.e.*, sleeve or head-end) of the filter into the distal opening of the delivery device, and making sure that the each of the hooks are aligned with its corresponding grooves/cavities on the inner lumen surface at the distal end of the catheter. The compressed vessel filter is positioned with the filter hooks next to the distal opening of the delivery catheter and the proximal end of the vessel filter aligned towards the proximal end of the delivery catheter. The surgeon first locates a suitable jugular or subclavian vein. An incision is made to access the vein. A guidewire is inserted into the vein and advanced towards the inferior vena cava. An introducer sheath together with its tapered dilator is advanced over the guidewire, and the distal portion of the introducer sheath is advanced into the inferior vena cava. The guidewire and the dilator are then removed, leaving the introducer sheath with its tip in the inferior vena cava. Venacavavogram or other imaging techniques may be used to position the introducer sheath for optimal placement of the vessel filter. The filter delivery device loaded with the vessel filter is then inserted into the introducer sheath and advanced toward the inferior vena cava. Once the delivery assembly is positioned for desired placement of the vessel filter, the surgeon holds the pusher-wire in place while simultaneously pulling the introducer sheath and the delivery catheter in a proximal direction. The introducer sheath and the delivery catheter are retracted over the pusher-wire, exposing the vessel filter. The pusher pad at the distal end of the pusher-wire forces the vessel filter to exit the filter delivery device and allows the vessel filter’s legs to expand and engage the vessel wall. The delivery assembly and the introducer sheath may then be removed.

[0074] FIG. 6H illustrates one variation of an introducer sheath 172 and dilator 174 combination. The dilator 174 is slid into the introducer sheath 172 by inserting the distal end 176 of the dilator 174 into the proximal opening of the introducer sheath 172. Once the dilator 174 is advanced all the way into the introducer sheath 172, the dilator hub 178 at the proximal end 180 of the dilator 182 tubing will engage the fluid infusion hub 184 at the proximal end 186 of the introducer sheath 172. An optional interlocking mechanism 188 may be provided to connect the dilator hub 178 to the fluid infusion hub 184 on the introducer sheath 172. The interlocking mechanism 188 may comprise a snap-on interface 190. For example, the fluid infusion hub 184 on the introducer sheath 172 may be configured with a groove/profile for receiving a corresponding protrusion 192 or raised profile on the dilator hub 178, such that the dilator hub 178 may be snapped onto the fluid infusion hub 184 on the introducer sheath 172.

[0075] As shown in FIG. 6H, the dilator 174 and the introducer sheath 172 are interlocked together and may be operated as a single unit. In this example, the overall length "L13" of the combined unit is 26.63 inches; the length "L14" of the dilator 174 measured from the base of the fluid infusion hub to the tip 176 of the dilator is 24.43 inches; the length "L15" of the tapered tip portion of the dilator 174 is 0.26 inches; the length "L16" of the introducer sheath 172 measured from the base of the fluid infusion hub to the tip 196 of the sheath is 21.66 inches; and the length "L17" of the tapered distal portion of the introducer sheath is 0.25 inches. Side ports 194 are provided along the length of the distal portion of the dilator such that fluid infused through the dilator 174 may exit the side ports 194 and dilate the blood vessel. The dilator/introducer sheath unit 210 may then be inserted over a guidewire into the patient's circulatory system. Once the distal end 196 of the introducer sheath 172 is placed at the desired location in the blood vessel, the surgeon may disengage the dilator 174 from the introducer sheath 172 and withdrawal the dilator 174 and the guidewire from the lumen of the introducer sheath 172.

[0076] With the lumen of the introducer sheath 172 freed of obstructions, the surgeon may then insert a delivery catheter 198 loaded with a vessel filter into the proximal opening on the introducer sheath 172, and advance the delivery catheter 198 along the length of the introducer sheath 172. Once the delivery catheter 198 is inserted all the way into the introducer sheath 172, the fluid infusion hub 202 on the proximal end of the delivery catheter will abut the fluid infusion hub 184 on the proximal end 186 of the introducer sheath 192. An optional interlocking mechanism 180 may be provided to connect the two fluid infusion hubs 184, 202 together, and thereby linking the delivery

catheter 198 and the introducer sheath 172 into a single operating unit. The delivery catheter tubing 204 and the introducer sheath 172 may then be displaced over the pusher-wire 206 as a signal unit. The interlocking mechanism 188 may comprise a snap-on interface. For example, the introducer sheath 172 may be configured with a groove/profile for receiving a corresponding protrusion 208 or raised profile on the delivery catheter 198, such that the fluid infusion hub 202 on the delivery catheter 198 may be snapped onto the fluid infusion hub 184 on the introducer sheath 172, as shown in FIG. 6I.

[0077] FIG. 6I illustrates a delivery catheter 198 inserted inside the lumen of the introducer sheath 172, and the proximal end of the introducer sheath 186 engages the fluid infusion hub 202 on the delivery catheter 198 and interlocks the two devices together. Also shown in FIG. 6I, a vessel filter 200 is loaded within the distal lumen of the delivery catheter 198 and a pusher-wire 206 is positioned within the proximal lumen of the delivery catheter 198. In this example, the overall length "L18" of the delivery catheter/introducer sheath assembly 212 is 35.32 inches; the length "L19" of the delivery catheter tubing 204 measured from the base of the fluid infusion hub to the tip of the delivery catheter is 21.96 inches; the length "L20" of the portion of the delivery catheter 198 that protrudes from the distal end 196 of the introducer sheath 172 is 0.29 inches; the length "L21" of the channel 216 in the delivery hub extension 218 that accommodates the sliding of the block-stop 220 is 3 inches; the length "L22" measured from the distal end of the block-stop 220 to the proximal end of the delivery hub extension is 0.3 inches; and length "L23" of the safety clip 222, which is also the maximum displacement distance for the pusher-wire 206, is 2.95 inches.

[0078] In this example, a delivery hub extension 218 is provided to guide the displacement of the pusher-wire 206. A block-stop 220 which is fixedly connected to the pusher-wire 206 is positioned within a channel 216 in the delivery hub extension housing 218. The block-stop 220 prevents the user from over withdrawal of the pusher-wire 206. As shown in FIG. 6I, when the pusher-wire 206 is fully displaced in the proximal direction, the block-stop 220 abuts the proximal wall of the delivery hub extension 218 and prevents further withdrawal of the pusher-wire 206. Optionally, the block-stop 220 may be configured with a cross-sectional profile, such as square, that matches the inner surface of the delivery hub extension housing 218 to prevent the pusher-wire 206 from rotating. This anti-rotational mechanism may be particularly useful when a deployment jig is implemented at the distal end 224 of the pusher-wire 206, since the rotation of the jig, which engages the vessel filter, may cause the legs of the vessel filter 200 to become entangled with each

other. However, in a design utilizing a pusher pad 226, such as the one shown in FIG. 6I, an anti-rotational mechanism is not necessary.

[0079] The safety clip 222 prevents the surgeon from prematurely deploying the delivery filter 200 by preventing the pusher-wire 206 from displacing in the distal direction. When the delivery catheter 198 is fully inserted into the introducer sheath and successfully engages the introducer sheath's interlocking mechanism 188, as shown in FIG. 6I, the surgeon may then remove the safety clip 222. Holding the handle 228 at the proximal end 230 of the pusher-wire 206 in place, the surgeon may then retract the delivery catheter/introducer sheath assembly 212, causing the delivery catheter tubing 204 and the introducer sheath 172 to simultaneously displace in the proximal direction and allowing the vessel filter 200 to deploy. Once the vessel filter 200 is successfully deployed, the surgeon may then withdrawal the delivery catheter/introducer sheath assembly 212 from the patient's circulatory system. In the example shown in FIG. 6I, the safety clip 222 comprises a tab such that the surgeon may easily push the safety clip off 222 the pusher-wire 206. Alternatively, a loop may be provided on the safety clip 222 so that the surgeon can easily pull the safety clip 222 off the pusher-wire 206. Instruction for removal of the safety clip 222 may be provided on the safety clip in the form of lettering and/or graphic icon.

[0080] Referring to FIG. 7A, a delivery catheter 232 with a centering mechanism 234 is illustrated. The centering mechanism 234 comprises a plurality of flexible elements 236 (e.g. wires, rods, etc.) configured around the distal end 238 of the delivery catheter 232 such that the flexible elements 236 flare outward from a longitudinal axis 240 of the catheter 232, as shown in FIG. 7B. The flexible elements may comprise a biocompatible metal, metal alloyed, polymer, or a combination thereof. When the delivery catheter is deployed inside a blood vessel, the flexible elements 236 push against the wall of the blood vessel and center the distal tip 238 of the catheter 232 within the blood vessel. In the example shown in FIG. 7A, the delivery catheter 232 is also configured with an optional feature for separating the hooks of a vessel filter to be loaded into the distal 238 end of the delivery catheter. As shown, grooves 242 are provided at the distal end of the inner lumen for receiving and separating the hooks.

[0081] FIG. 7C illustrates a vessel filter 246 loaded in the distal end 238 of a delivery catheter 232. The delivery catheter 232 is slidably disposed within an introducer sheath 248. The wall of the introducer sheath compresses the flexible elements 236 at the distal end of the delivery catheter and allows the physician to advance the delivery catheter 232 within the lumen 250 of the introducer sheath 248. When the introducer sheath 248 is

retracted from the distal end 238 of the delivery catheter 232 and exposes the flexible elements 236, the flexible elements 236 will flare outward. The distal end 252 of each of the flexible elements 236 may then contact the vessel wall and pushed against the vessel wall. The collective action of all flexible elements 236 will center the tip of the delivery catheter 232 within the blood vessel. The physician may then deploy the vessel filter 246 by either retracting the delivery catheter 232 and the introducer sheath 248, thereby exposing the vessel filter 246, or by pushing the vessel filter 246 out of the distal end 238 of the delivery catheter 232 with a pusher-wire 254.

[0082] Referring to FIG. 7D, another variation of a centering mechanism is illustrated. In this variation, a plurality of loops 231, 233, 235, 237 are connected to the distal end of a catheter 239. The loops may comprise of metallic material, polymeric material, or a combination thereof. In the expended state the loops 231, 233, 235, 237 expand outwardly away from the longitudinal axis of the catheter 239. The catheter may be placed inside of an introducer sheath for deployment. The wall of the sheath forces the loops to collapse inward toward the longitudinal axis. Optional grooves may be provided on the inner wall of the catheter 239 to separate the hooks on a vessel filter loaded within the catheter 239.

[0083] In one variation, the flexible elements 236 for centering the catheter 232 is attached to the distal end 238 of a catheter 232 through a spline cap 260 serving as the interface. An example of a spline cap 260 with holes 262 for receiving the flexible elements 236 is shown in FIG. 8A–8C. In this design, the spline cap 260 is configured with a lumen 264 running from the distal end 266 of the spline cap 260 to the proximal end 268 of the spline cap 260, as shown in FIG. 8A. The proximal end 268 of the spline cap is configured with a bore 270 to receive a catheter 272, as shown in FIG. 8B. Six holes 262 are provided on the distal end 266 of the spline cap 260 to receive six flexible elements 236, as shown in FIG. 8C. The flexible elements may comprise of six flexible metal wires, or six flexible polymeric rods, or a combination thereof. Six optional slots 274 are also built into the inner wall 276 of the spline cap 260 for receiving six corresponding hooks on a vessel filter 246. FIG. 9A and 9B shows the cross-sectional view of the spline cap 260. In this variation, each of the holes 262 for receiving the flexible elements 236 has a length “L24” of 0.138 inches, as shown in FIG. 9A. The diameter of the spline cap 260 at the distal end “R9” is 0.17 inches; the diameter at the proximal end “R10” is 0.14 inches; the diameter of the lumen “R11” is 0.088 inches. The length “L25” of each of the grooves is 0.04. As shown in FIG. 9B, in this example, the ledge 278 at the proximal end of each of the groove 274 is

configured with a profile configured to match the curvature of the hook. The curved profile at on the ledge 278 of the groove 274 may help maintain the shape of the distal portion of the hook and/or prevent fatigue of the material comprising the hook.

[0084] In another aspect of the invention, a pusher device 280 with an attachment 282 for interfacing with the proximal end 284 of a vessel filter 286 is implemented for loading and unloading of the vessel filter 286 from the delivery catheter 288. The pusher device 280 may comprise a flexible elongated body 290 (e.g., wire, rod, etc.) with a jig 292 attached to the distal end of the flexible elongated body 290, as shown in FIG. 10A. In this example, the jig 292 comprises a base 294 wrapping around the distal tip 296 of the pusher-wire 290, as shown in FIG. 10C. An elongated member 298 extends from the distal end 296 of the pusher-wire in the distal direction. At the distal end 300 of the elongated member, two prongs 302, 304 extend laterally and curve upward for engaging the neck 306 of a vessel filter 286. Referring back to FIG. 10A and 10B, in this variation, the jig 292 has an overall length "L26" of 0.4 inches and an overall diameter "R12" of 0.072 inches; the elongated member 298 has a length "L27" of 0.25 inches and width "L28" of 0.03 inches; the height "L29" of each of the two prongs 302, 304 is 0.023 inches. The two prongs 302, 304 may have a tapered or rounded atraumatic configuration to prevent the jig 292 from causing damages to the inner wall of a blood vessel during deployment.

[0085] FIG. 11 illustrates a pusher-wire 290 with a deployment jig 292 at the distal end, extending out the distal lumen of a delivery catheter 288 to engage a vessel filter 286. In this variation, the deployment jig 292 is designed with two lateral prongs 302, 304 which can be placed around the neck 306 of the vessel filter 286 and engages the sleeve 308 or the head of the vessel filter 286. The deployment jig 292 allows the user to pull on the vessel filter 286 and facilitate the loading of the vessel filter 286 into the lumen of the delivery catheter 288. The deployment jig 292 is also designed to release the vessel filter upon deployment by minimizing the surface contact between the vessel filter 286 and the deployment jig 292. One of ordinary skill in the art having the benefit of the disclosure herein would appreciate that other gripping or interlocking mechanism may also be implemented at the distal end of the pusher-wire as the deployment jig for engaging the proximal portion of the vessel filter.

[0086] Referring now to FIG. 12, another variation of a pusher-wire 310 is illustrated. In this design the pusher-wire comprises an elongated flexible body 312 (e.g., wire, rod, etc.), a pusher pad 314 attached to the distal end of the elongated flexible body 312 for applying a force onto the proximal end 314 of the vessel filter 316, and an extension

wiring 318 connecting a receptacle 320 to the pusher pad 314. The receptacle 320 is configured to receive the hooks on the legs of the vessel filter 316 and to keep the hooks separated from each other, such that the legs of the filter will not be entangled with each other. Preferably, the connection between the extension wiring 318 and the pusher pad 314 is offset from the longitudinal axis of the pusher-wire 310 such that it does not interfere with the placement of the vessel filter 316 immediately distal 322 of the pusher pad 314. The extension wire may comprise Nitinol.

[0087] The pusher-wire 310 may be placed inside of a catheter 324 to form a vessel filter delivery device 326 as shown in FIG. 13. In this example, the receptacle 320 is configured with a plurality of holes 326, each of which is designed to receive the distal end of a filter leg. The distal end of each of the legs may have a hook. The holes 326 may be large enough to accommodate the hooks in their expanded normal state (*i.e.*, curved). However, it is preferable that the hooks comprise of shape memory alloy and are straightened before they are inserted into their corresponding holes 326 in the receptacle 320. To load a vessel filter 316 into the delivery device 326, the user may advance the distal portion of the pusher-wire 310 out of the distal lumen opening 328 of the delivery catheter 324. The vessel filter 316 is placed between the pusher pad 314 and the receptacle 320, and the legs 330 of the vessel filter 316 are inserted into the corresponding holes 326 on the receptacle 320. The user may pull on the proximal end of the pusher-wire 310, which extends from the proximal end of the delivery catheter 324, and drawn the distal portion of the pusher-wire 310 and the loaded vessel filter 316 into the lumen of the catheter 324.

[0088] The vessel filter delivery device 326 loaded with the vessel filter 316 may be inserted into an introducer sheath 332 that has been positioned within the circulatory system of a patient through methods that are well known to one of ordinary skill in the art. The vessel delivery device 326 is advanced along the length of the introducer sheath 332 until the distal end 334 of the delivery catheter 324 protrudes from the introducer sheath's 332 proximal lumen opening. FIG. 14A illustrates a delivery catheter 324 with a pusher-wire 310 having a vessel filter 316 loaded on the receptacle 320; the delivery catheter 324 being slidably disposed within the lumen of the introducer sheath 332.

[0089] To deploy the vessel filter 316 the user may retract the delivery catheter 324 and the introducer sheath 322 at the same time to expose the distal portion of the pusher-wire 310 and the vessel filter 316. The arms 336 on the vessel filter 316 expand and engage the wall of the blood vessel, as shown in FIG. 14B. The user may then advance the pusher-

wire 310 in the distal direction and allow the legs 330 of the vessel filter 316 to slide out of the receptacle 320 at the distal end of the pusher-wire 310. The legs 330 expand and the hooks at the distal end of the legs 330 are embedded into the wall of the blood vessel. With the arms 336 and the legs 330 of the vessel filter 316 in the expanded positions, the receptacle 320 at the distal end of the pusher-wire 310 may be retrieved by pulling on the pusher-wire 310 and allowing the receptacle 320 to slide through one of the gaps between the expanded legs 330 and arms 336. The distal portion of the pusher-wire 310 along with its receptacle 320 can then be retracted into the lumen of the delivery catheter 324. The delivery catheter 324 and its introducer sheath 332 may then be removed from the body of the patient.

[0090] Alternatively, the compressed vessel legs 330 may have enough tension such that once the delivery catheter and the introducer sheath are retracted, as shown in FIG. 14B, the legs 14 will pop out of the receptacle. The holes on the receptacle and/or the hooks on the legs may be configured to facilitate the legs from exiting the receptacle when they are not compressed by the delivery catheter. In another variation, the hooks may comprise of Nitinol wires that are straightened before they are inserted into the holes on the receptacle. These straightened hooks may allow the legs of the vessel filter to disengage from the receptacle more easily. Once the legs are deployed, the patient's inner body temperature will force the straitened hooks to convert back into its original hook-shape and engage the inner wall of the blood vessel.

[0091] In another design, a second wiring having a jig or attachment mechanism at the distal end of the wiring may be placed within the delivery catheter along with the pusher-wire. The pusher pad 314 may have a side channel to allow the second wiring to pass-through. The jig at the distal end of the second wiring may engage the vessel filter sleeve. The delivery catheter and the introducer sheath are first partially withdrawn to expose the receptacle. Holding the second wiring in place to secure the filter in position, the pusher pad may then be advanced to push the receptacle forward through the extension wiring. As the consequence, the hooks at the distal end of the legs disengage from the receptacle and expand outward. The delivery catheter and the introducer sheath may then be completely retracted to expose the entire vessel filter. The jig on the second wiring is then detached from the vessel filter, and the second wiring along with the pusher-wire are retracted into the lumen of the delivery catheter. With the vessel filter deployed, the delivery catheter and the introducer sheath, along with the pusher-wire and the second wiring, may then be removed from the patient's body.

[0092] Alternatively, the second wiring, which engages the sleeve of the vessel filter, along with the pusher pad may be held in place while the operator completely retracts the delivery catheter and the introducer sheath to expose the entire vessel filter. The second wiring may then be utilized to pull vessel filter proximally and slide the hooks out of the receptacle. Once the vessel filter is deployed, the second wiring and the pusher-wire with the receptacle may then be retraced into the lumen of the delivery catheter. The operator may then remove the delivery catheter and the introducer sheath, along with the pusher-wire and the second wiring, from the patient's body. One of ordinary skill in the art having the benefit of this disclosure would appreciate that other variations of mechanisms may also be configured to disengage the legs of the vessel filter from the receptacle.

[0093] FIG. 15A illustrates one variation of a filter hook/leg receptacle 320. In this variation, the receptacle comprises a spline 338 with a plurality of orifices 340 for receiving the hooks. The proximal portion 342 of the receptacle 320 is configured with a cone-shaped profile 344. The cone-shaped profile may facilitate the retrieval of the receptacle 320 after the filter has been deployed by allowing the receptacle 320 to pass between the legs of the deployed filter with limited obstruction. A plurality of orifices 340 is provided on the cone-shaped profile 344 to receive the hooks and/or legs of the vessel filter. The cone-shaped profile 344 may also minimize obstruction and allow for easy insertion and smooth deployment of the legs. Preferably, the receptacle 320 has a circumferential outer surface 346 that matches or approximates the inner lumen of the delivery catheter, as shown in FIG. 15B, which may prevent kinking of the catheter and facilitate smooth advancement of the pusher-wire within the lumen of the catheter.

[0094] FIG. 15C is a cross-sectional view of this particular receptacle 320. In this example, the outer diameter of the receptacle 320 is 0.08 inches; the length of the receptacle "L30" is 0.380 inches; the base of the receptacle has a length "L31" of 0.147 inches; the depth "L32" of each of the holes 340 measure from the proximal end 348 of the receptacle 320 is 0.305 inches. To accommodate a filter with six hooks, six holes 340 are evenly distributed around a center opening 350, as shown in FIG. 15D. The center opening 350 is configured for receiving the distal end of the extension wire. The extension wire may be bonded into the center opening 350 of the receptacle 320. The spline 338 may comprise a metal, a metal alloy, or a polymeric material. The extension wire 318 may be a Nitinol wire that is 0.013 inches in diameter. As shown in FIG. 12, the pusher pad 314 may also be configured with a cone-shaped proximal profile 352, and a circumferential surface 354 matching or approximating the inner lumen of the delivery catheter 324. This may allow

the pusher pad 314 to keep the extension wire connection 356 away from the center of the catheter to allow smoother deployment of the vessel filter 316. The pusher pad 314 may be of various shapes and comprise various materials (*e.g.*, electrometric materials, metal, metal alloys, polymers, etc.) that are well known to one of ordinary skill in the art. One of ordinary skill in the art having the benefit of this disclosure would also appreciate that the receptacle 320 may adapt various other geometric shapes and still serve essentially the same function of keeping hooks on the legs separated from each other.

[0095] In another example, the receptacle is made of a spline 358 with an orifice 360 surrounding a post 362, as shown in FIG. 16A. The proximal end 364 of the post 362 can be connected to an extension wire on the pusher device. The inner circumferential surface of the spline 358 is embedded with a series of grooves 366 for separating the hooks at the distal ends of the legs, as shown in FIG. 16B.

[0096] In FIG. 17, another variation of a delivery catheter 3 is illustrated. In this configuration, a plurality of orifices 5 are provided at the distal portion of the delivery catheter for receiving and separating hooks on a vessel filter loaded within the lumen of the delivery catheter. The orifices 5 may be placed close to the distal end 7 of the catheter 3. In one example, the orifices 5 are placed within 2 mm from the distal end 7 of the catheter 3.

[0097] In one exemplary application, the vessel filter is inserted into the catheter by compressing its legs and corresponding arms, if any. The delivery catheter may be configured with six orifices for receiving hooks from a six legged filter with a hook located at the distal end of each of the legs. The vessel filter may be loaded from either distal or proximal end of the delivery catheter depending on the particular catheter design. For example, one may load the vessel filter from the distal end of the catheter by first inserting the proximal end (*i.e.*, the sleeve of the vessel filter) into the distal lumen of the catheter. As the filter is completely advanced into the lumen of the catheter, the hooks on each of the legs will pop into the corresponding orifice on the delivery catheter. If the hooks are long enough, the hooks may pass through the orifices and protrude from the orifices' outer openings on the outer circumferential surface of the delivery catheter. As the delivery catheter with the loaded vessel filter is inserted into the proximal end of an introducer sheath, the protruding portion of the hooks will be forced back into the orifices. As the delivery catheter, along with the loaded vessel filter, is advanced towards the distal end of the introducer sheath, the hooks stay in their corresponding orifices and glide along the inner lumen wall of the introducer sheath. A pusher-wire with a pusher pad may be positioned within the lumen of the delivery catheter to keep the loaded vessel filter at the

distal portion of the delivery catheter, as the delivery catheter is being displaced within the introducer sheath.

[0100] Once the delivery catheter and the corresponding introducer sheath is properly positioned within the blood vessel, the operator may then deploy the vessel filter by holding the pusher-wire in place, while simultaneously withdraw the delivery catheter and the corresponding introducer sheath. As the delivery catheter is withdrawn, the hooks on the vessel filter legs will be forced out of their corresponding orifices in the delivery catheter. The inner edge of each of the orifices maybe tapered on the distal side, which is closer to the distal end of the catheter, to facilitate the filter hooks from sliding out of the orifices when the delivery catheter is retracted. Once the delivery catheter and the corresponding introducer sheath are fully retracted, the legs and/or arms on the exposed delivery catheter may then expand and engage the inner wall of the blood vessel.

[0101] In FIG. 18, another variation of a delivery catheter 9 is shown. In this configuration, a plurality of slots 11 are provided at the distal end 13 of a catheter 9 for receiving and separating hooks on a vessel filter loaded within the lumen of the delivery catheter. As shown in FIG. 18, each of the slots spans across the thickness of the catheter wall, and opens toward the distal end 13 of the catheter. In one variation, the base 15 of each of the slots comprises a flat surface, as shown in FIG. 18. In another variation the base each of the slots has a rounded or otherwise curved profile. In the variation shown in FIG. 18, the slots are configured to receive a vessel filter with six equal length legs. However, if the legs of the vessel filter have varying lengths, the length of the slots along the longitudinal axis of the catheter may also be varied accordingly to accommodate the various vessel filter legs.

[0102] Referring now to FIG. 19, another example of an implantable vessel filter 370, which may be deployed by the filter delivery device described above, is illustrated. In this variation, the vessel filter is made of elongated wires, and the wires are held together at the filter's proximal end by a hub 372 (*e.g.*, sleeve) where they are plasma welded together to the hub or otherwise joined. In the low temperature martensitic phase of wires made of thermal shape memory material (*e.g.*, Nitinol alloy), the sets of wires can be straightened and held in a straight form that can pass through a length of fine plastic tubing with an internal diameter of approximately 2 mm (*e.g.*, 8 French catheter). In its high temperature austenitic form, the vessel filter 370 recovers a preformed filtering shape as illustrated by FIG. 19. Similarly, wires of spring metal can be straightened and compressed within a catheter or tube and will diverge into the filter shape of FIG. 19 when the tube is removed.

In its normal expanded configuration or preformed filtering shape, the vessel filter 370 comprises a double filter, having a first proximally positioned basket section 374 and a second distally disposed filter basket section 376. The two filter basket sections provide peripheral portions which can both engage the inner wall of a body vessel at two longitudinally spaced locations, and the two filter basket sections are generally symmetrical about a longitudinal axis passing through the hub 372. On the other hand, the first filter basket section 374, which may act as a centering unit, may not always touch the vessel wall on all sides.

[0103] The first filter basket section 374 is formed from short lengths of wire, which form legs 378 extending angularly, outwardly and then downwardly away from the hub 372 and toward the distal end 380 of the vessel filter 370. Each leg 378 has a first leg section 382, which extends angularly outwardly from the hub 372 to a transition section 384, and an outer leg section 386, which extends angularly from the transition section 384 toward the distal direction of the filter. The outer leg sections 386 are substantially straight lengths with ends that lie on a circle at their maximum divergence and engage the wall of a vessel at a slight angle (preferably within a range of from ten to forty-five degrees) to center the hub 372 within the vessel. For a filter which is to be removed by grasping the hub 372, it may be important for the hub to be centered. The filter may be configured with six wires 378 of equal length extending radially outward from the hub 372 and circumferentially spaced, such as, for example, by sixty degrees of arc.

[0104] The second filter basket section 376 is the primary filter and can include up to twelve circumferentially spaced straight wires 388 forming downwardly extending legs which tilt outwardly of the longitudinal axis of the filter 370 from the hub 372. A filter with a six wire configuration is discussed in this example, and the wires are of equal length. Alternatively, the length of the wiring may be staggered. The wires 388 are preferably much longer than the wires 378, and have distal tip sections which are uniquely formed, outwardly oriented hooks 390 which lie on a circle at the maximum divergence of the wires 388. There may be from three to twelve wires 388 formed with hooks 390, and in some instances, the wire legs 378 may include similarly formed hooks at the free ends thereof. The wires 388, in their expanded configuration of FIG. 17, are at a slight angle to the vessel wall, preferably within a range of from ten to forty-five degrees, while the hooks 390 penetrate the vessel wall to anchor the filter against movement. The wires 388 are radially offset relative to the wires 90 and may be positioned halfway between the wires 378 and also may be circumferentially spaced by sixty degrees of arc. Thus, the combined filter

basket sections 374 and 376 can provide a wire positioned at every thirty degrees of arc at the maximum divergence of the filter sections. The filter section 376 forms a concave filter basket opening toward the distal end of the filter 370, while the filter section 374 forms a concave filter proximal of the filter section 376.

[0105] Furthermore, the hooks 390 on the distal legs may be further configured such that withdrawal force to which the hook is subjected will cause flexure in the juncture sections 392 so that the hook extends in the distal direction of the filter to a position parallel or semi-parallel with the axis of the leg 388. For example, the juncture section 392 may have considerably reduced cross-section relative to the cross-section of the leg 388 and the remainder of the hook 390 so that the stress exerted by the withdrawal tension may force it to bend outward. With the hook so straightened, it can be withdrawn without tearing the vessel wall, leaving only a small puncture. In an alternative design, the entire hook 390 can be formed with a cross-section throughout its length, which is less than that of the leg 388. This may result in straightening of the hook over its entire length in response to a withdrawal force. Such elasticity in the hook structure may prevent the hook from tearing the vessel wall during withdrawal.

[0106] In addition, a hook or attachment interface may be provided at the proximal end of the hub to allow the operator to manipulate the vessel filter through an elongated wire with a matching interface for engaging the hook or the attachment interface. For example, a hook positioned at the proximal end of the hub 372 may facilitate the removal of the vessel filter. The operator may engage the hook with an elongated wire and hold the vessel in place while simultaneously advance a catheter over the implanted vessel filter. The catheter forces the legs on the vessel filter to collapse and slide into the lumen of the catheter. Once the vessel filter is inside the catheter the catheter, along with the retracted vessel filter, may then be removed from the patient's body.

[0107] This invention has been described and specific examples of the invention have been portrayed. While the invention has been described in terms of particular variations and illustrative figures, those of ordinary skill in the art will recognize that the invention is not limited to the variations or figures described. In addition, where methods and steps described above indicate certain events occurring in certain order, those of ordinary skill in the art will recognize that the ordering of certain steps may be modified and that such modifications are in accordance with the variations of the invention. Additionally, certain of the steps may be performed concurrently in a parallel process when possible, as well as performed sequentially as described above. Therefore, to the extent there are

variations of the invention, which are within the spirit of the disclosure or equivalent to the inventions found in the claims, it is the intent that this patent will cover those variations as well. Finally, all publications and patent applications cited in this specification are herein incorporated by reference in their entirety as if each individual publication or patent application were specifically and individually put forth herein.

CLAIMS

What is claimed as new and desired to be protected by Letters Patent of the United States is:

1. A vessel filter assembly, comprising:
 - a vessel filter portion, comprising:
 - a sleeve; and
 - a plurality of elongated legs extending distally from said sleeve, said plurality of elongated legs being configured to expand radially from a longitudinal axis of said sleeve and forming a filter in an expanded position, each of said plurality of legs comprising a hook located at a distal end thereof such that when said legs are expanded in a body vessel the hooks engage an inner wall of the vessel; and
 - a filter delivery portion, comprising:
 - an elongated catheter including a lumen extending from a proximal end to a distal end, the lumen being configured to receive said vessel filter and maintain said vessel filter in a compressed configuration, a plurality of grooves being provided on an inner surface of said catheter at said distal end, said grooves being configured for receiving said hooks and for preventing said plurality of legs from entangling with each other.
2. The vessel filter assembly according to claim 1, wherein said filter delivery portion further comprises a flexible rod slidably positioned within said elongated catheter for applying pressure on said sleeve when said vessel filter is to be deployed from the distal end of said elongated catheter.
3. The vessel filter assembly according to claim 2, wherein said vessel filter portion further comprises a plurality of arms extending distally from said sleeve, wherein said plurality of arms are configured to expand radially from a longitudinal axis of said sleeve to form a second filter in an expanded position.
4. The vessel filter assembly according to claim 1, wherein said filter is conically shaped.
5. The vessel filter assembly according to claim 3, wherein said arms are compressed by an inner wall of said catheter, and wherein said arms do not engage said

plurality of grooves when said vessel filter is positioned within the lumen of said catheter.

6. The vessel filter assembly according to claim 2, wherein a length along the longitudinal axis of said catheter for each of said grooves is 5 mm or less.
7. The vessel filter assembly according to claim 2, wherein a length along the longitudinal axis of said catheter for each of said grooves is 3 mm or less.
8. The vessel filter assembly according to claim 2, wherein said vessel filter comprises six elongated legs, and wherein said elongated catheter is provided with six grooves equally spaced along the inner circumferential surface of said catheter.
9. The vessel filter assembly according to claim 3, wherein each of said elongated legs and each of said arms comprises Nitinol.
10. The vessel filter assembly according to claim 3, wherein each of said elongated legs and each of said arms comprises a shape memory polymer.
11. The vessel filter assembly according to claim 3, wherein each of said elongated legs and each of said arms comprises a non-ferrous metal.
12. The vessel filter assembly according to claim 3, wherein each of said elongated legs and each of said arms comprises a shape memory alloy.
13. The vessel filter assembly according to claim 2, wherein a length along the longitudinal axis of said catheter for each of said grooves is approximately the length of said hooks along the longitudinal axis of each of said hook's corresponding leg.
14. The vessel filter assembly according to claim 2, wherein a length along the longitudinal axis of said catheter for each of said grooves is equal to or less than three times a length of said hooks along the longitudinal axis of each of said hook's corresponding leg.
15. The vessel filter assembly according to claim 1, wherein said grooves are configured to prevent the vessel filter from sliding proximally along the lumen of the catheter once said hooks are placed within said grooves.

16. The vessel filter assembly according to claim 1, wherein each of said grooves is configured with a distal end opening at the distal tip of said elongated catheter to allow said hooks to slide out of said grooves, and wherein a proximal end of each of said grooves includes a ledge for blocking said hooks and preventing said vessel filter from migrating in the proximal direction along the length of the catheter.

17. The vessel filter assembly according to claim 5, wherein each of said grooves is configured with a distal end opening at the distal tip of said elongated catheter to allow said hooks to slide out of said grooves, and wherein a proximal end of each of said grooves includes a ledge for blocking said hooks and preventing said vessel filter from migrating in the proximal direction along the length of the catheter.

18. The vessel filter assembly according to claim 2, wherein said grooves are configured such that said grooves prevent said vessel filter from sliding proximally along the lumen of the catheter once said hooks are placed within said grooves.

19. The vessel filter assembly according to claim 1, wherein said elongated catheter comprises a flexible tubing and a spline cap attached to a distal end of said tubing, said spline cap being configured with said plurality of grooves at the distal end thereof, said grooves being positioned on an inner wall surrounding a lumen of said spline cap, and said grooves being configured to receive said hooks and to prevent said plurality of legs from entangling with each other.

20. The vessel filter assembly according to claim 19, wherein said grooves are configured to prevent said vessel filter from sliding proximally along the lumen of the catheter once said hooks are placed within said grooves.

21. The vessel filter assembly according to claim 20, wherein said spline cap comprises a metal.

22. The vessel filter assembly according to claim 19, wherein each of said grooves is configured with a distal end opening at the distal end of said spline cap to allow said hook to slide out of said groove, and wherein a proximal end of each of said grooves includes a ledge for blocking said hook and preventing said vessel filter from migrating in the proximal direction along a length of said flexible tubing.

23. The vessel filter assembly according to claim 1, wherein said elongated catheter further comprises a mechanism configured for centering the distal end of said catheter within a blood vessel.

24. The vessel filter assembly according to claim 23, wherein said mechanism configured for centering the distal end of said catheter comprises a plurality of loops attached to the distal end of said elongated catheter.

25. The vessel filter assembly according to claim 23, wherein said filter delivery portion further comprises a sheath slidably disposed around said elongated catheter such that when the distal end of said elongated catheter is retracted within a lumen of said sheath said mechanism is compressed and secured within the lumen of said sheath.

26. The vessel filter assembly according to claim 1, wherein said filter delivery portion further comprises a plurality of flexible elements attached to the distal end of said catheter.

27. The vessel filter assembly according to claim 26, wherein each of said plurality of flexible elements comprises a shape memory material.

28. The vessel filter assembly according to claims 26, wherein said plurality of flexible elements are configured to flare outward from a longitudinal axis along the length of the catheter when said flexible elements are not compressed.

29. The vessel filter assembly according to claim 28, wherein each of said plurality of flexible elements comprises Nitinol.

30. The vessel filter assembly according to claim 28, wherein each of said plurality of flexible elements comprises a shape memory material.

31. The vessel filter assembly according to claim 28, wherein said filter delivery portion further comprises a sheath slidably disposed around said elongated catheter such that said sheath can be displaced along the length of said catheter, and wherein when a distal end of said sheath is displaced in the distal direction beyond the distal end of said elongated catheter, said sheath forcing said plurality of flexible elements to compress toward the longitudinal axis of said catheter.

32. The vessel filter assembly according to claim 28, wherein said grooves are configured to prevent said vessel filter from sliding proximally along the lumen of the catheter once said hooks are placed within said grooves.

33. The vessel filter assembly according to claim 28, wherein said elongated catheter comprises a flexible tubing and a spline cap attached to a distal end of said tubing, said spline cap being configured with said plurality of grooves for receiving said hooks and a plurality of holes for securing said plurality of flexible elements on the distal end of said elongated catheter.

34. The vessel filter assembly according to claim 2, wherein said flexible rod further comprises a jig attached to a distal end of said flexible rod, said jig being configured to capture said sleeve of said vessel filter for drawing said vessel filter into the lumen of said elongated filter.

35. The vessel filter assembly according to claim 34, wherein said jig is further configured to release said vessel filter upon deployment of the vessel filter.

36. The vessel filter assembly according to claim 34, wherein said jig comprises an elongated member extending from the distal end of said rod, and two prongs extending laterally from a distal end of said elongated member.

37. The vessel filter assembly according to claim 36, said prongs being configured to partially surround a neck on said filter assembly located distal of said sleeve.

38. The vessel filter assembly according to claim 34, wherein said grooves are configured to prevent the vessel filter from sliding proximally along the lumen of the catheter once said hooks are placed within said grooves.

39. The vessel filter assembly according to claim 34, wherein said filter delivery portion further comprises a plurality of flexible elements attached to the distal end of said catheter, configured for centering the distal end of said elongated catheter within a vessel.

40. The vessel filter assembly according to claim 1, wherein each of said plurality of legs comprises a shape memory material.

41. A vessel filter delivery device for implanting an expandable vessel filter in a hollow body organ in a human, comprising an elongated flexible tube including a lumen extending from a proximal end to a distal end, wherein a distal portion of said lumen is configured for housing said expandable vessel filter in a compressed state, wherein said tube comprises a plurality of slots positioned at said distal end on an inner circumferential surface thereof, each of said slots being configured to receive one of a plurality of hooks on said expandable vessel filter, a distal end of said slots opening at the tip of said tube to allow said hooks to slide out, and a proximal end of said slot including a ledge to prevent the vessel filter from migrating towards said proximal end of said tube.

42. The vessel filter delivery device according to claim 41, further comprising an elongated flexible wire slidably disposed within the lumen of said elongated flexible tube, wherein a distal end of said elongated flexible wire is configured to apply a force on said vessel filter to deploy said vessel filter from the lumen of said tube.

43. The vessel filter delivery device according to claim 42, wherein said vessel filter forms a conical shape in an expanded state, and wherein said hooks are located at a distal end of said vessel filter.

44. The vessel filter delivery device according to claim 41, wherein each of said slots has a length along the length of the tube that is equal to or less than one-fourth of an inch.

45. The vessel filter delivery device according to claim 41, wherein each of said slots has length along the length of the tube that is equal to or less than one-eighth of an inch.

46. The vessel filter delivery device according to claim 41, wherein said elongated flexible tube comprises a polymer tubing and a spline cap attached to a distal end of said polymer tubing, said spline cap being configured with said plurality of slots.

47. The vessel filter delivery device according to claim 46, wherein said spline cap comprises a metallic material.

48. The vessel filter delivery device according to claim 41, further comprising a plurality of flexible elements including first and second ends, each of said flexible

elements being attached to the distal end of said elongated flexible tube at the first end of said flexible element, the second end of said flexible element extending distally away from the distal end of said elongated flexible tube and outwardly away from a longitudinal axis of said elongated flexible tube.

49. The vessel filter delivery device according to claim 48, further comprising a sheath slidably disposed over said elongated flexible tube.

50. The vessel filter delivery device according to claim 42, wherein said elongated flexible wire further comprises a jig attached to the distal end of said flexible wire, wherein said jig is configured to receive a proximal portion of said vessel filter.

51. The vessel filter delivery device according to claim 42, further comprising an introducer sheath, wherein a lumen in said introducer sheath is configured to slidably receive said elongated flexible tube, the introducer sheath comprising an interlocking mechanism for temporality securing said elongated flexible tube within the lumen of said introducer sheath such that the introducer sheath and the elongated tubing can be displaced inside a blood vessel as a single unit.

52. The vessel filter delivery device according to claim 41, wherein said elongated flexible tube further comprises a mechanism configured for centering the distal end of said catheter within a blood vessel.

53. The vessel filter delivery device according to claim 52, wherein said mechanism configured for centering the distal end of said catheter comprises a plurality of loops attached to the distal end of said elongated flexible tube.

54. A vessel filter delivery system, comprising:
the vessel filter delivery device as recited in claim 42;
an introducer sheath including a lumen configured to slidably receive said vessel filter delivery device, the proximal end of the introducer being configured with an interlocking mechanism for securing the vessel filter delivery device within the lumen of said introducer sheath such that the vessel filter delivery device and the introducer sheath can be displaced inside a blood vessel as a single unit; and

a dilator, configured for insertion into the lumen of said introducer sheath, the proximal portion of said dilator comprising an interface for engaging the interlocking mechanism on the introducer sheath, such that when the dilator is inserted inside the lumen of the introducer, the dilator and the introducer can be connected to each other and inserted into said blood vessel as a single unit.

55. The vessel filter delivery system according to claim 54, further comprising an expandable vessel filter.

56. A vessel filter delivery device for implanting an expandable vessel filter in a hollow body organ in a human comprising:

a catheter including a lumen;

an elongated flexible wire slidably disposed within the lumen of said catheter;

a pusher pad attached to a distal end of said elongated flexible wire;

an extension wire with a distal end and a proximal end, the proximal end of said extension wire being connected to said pusher pad; and

a receptacle attached to the distal end of said extension wire, said receptacle being configured for receiving distal ends of a plurality of appendages of a vessel filter.

57. The vessel filter delivery device according to claim 56, further comprising a vessel filter positioned within said lumen of said catheter between said pusher pad and said receptacle, wherein the distal end of said plurality of appendages of said vessel filter are inserted within said receptacle.

58. The vessel filter delivery device according to claim 57, wherein said vessel filter comprises a sleeve and a plurality of appendages extending distally from said sleeve, said plurality of appendages being configured to expand radially from a longitudinal axis of said sleeve to form a filter in an expanded position, each of said plurality of appendages comprising a hook located at a distal end of said appendages such that when said appendages are expanded in a body vessel, said hooks engage an inner wall of the vessel.

59. The vessel filter delivery device according to claim 57, wherein said vessel filter further comprises a hook attached to the distal end of each of said plurality of appendages, wherein said hooks are straightened and inserted into said receptacle.

60. The vessel filter delivery device according to claim 59, wherein said receptacle is configured with a plurality of holes, each of said holes being configured to receive one of said plurality of appendages.

61. The vessel filter delivery device according to claim 60, wherein a connection between said pusher pad and said extension wire is offset from a central axis of said pusher pad.

62. The vessel filter delivery device according to claim 58, wherein said receptacle is configured with a cone-shaped profile at a proximal end thereof, and wherein said extension wire is connected to the tip of the cone-shaped profile at the proximal end of said receptacle.

63. The vessel filter delivery device according to claim 62, wherein said receptacle is further configured with a plurality of orifices on said cone-shaped profile for receiving said plurality of appendages.

64. The vessel filter delivery device according to claim 63, wherein said pusher pad and said receptacle are comprised of a metallic material.

65. The vessel filter delivery device according to claim 64, wherein said extension wire comprises Nitinol.

66. The vessel filter delivery device according to claim 56, wherein said receptacle is configured with a plurality of slots for receiving said appendages, each of said slots being configured to receive one of said plurality of appendages.

67. The vessel filter delivery device according to claim 57, wherein said vessel filter appendages comprise a plurality of long appendages and a plurality of short appendages, and wherein said receptacle is configured with a plurality of slots for receiving distal ends of said plurality of long appendages.

68. The vessel filter delivery device according to claim 67, wherein said plurality of long appendages and short appendages number six, said receptacle being configured with six slots evenly distributed around a longitudinal axis thereof.
69. A method of delivering a vessel filter comprising the steps of:
inserting a vessel filter into a distal end of a catheter; and
placing a plurality of hooks on the vessel filter into separate grooves located at the distal end of the catheter.
70. The method according to claim 69 further comprising the steps of:
inserting the catheter into a introducer sheath positioned within a patient's blood vessel; and
locking the catheter onto the introducer sheath at a proximal end of the introducer sheath.
71. The method according to claim 70 further comprising the steps of:
holding in place a pusher wire positioned proximal to the vessel filter and
simultaneously retract the catheter and the introducer sheath; and
releasing the vessel filter within the blood vessel.
72. The method according to claim 69, wherein each of the grooves includes a distal end opening to allow the hooks to slide out of the grooves, and a proximal end of each of the grooves includes a ledge for blocking the hooks and preventing the vessel filter from migrating proximally.
73. A vessel filter implant apparatus comprising:
an elongated catheter; and
means for separating hooks on a vessel filter, and keeping the hooks at a distal end of the catheter.
74. The vessel filter implant apparatus according to claim 73 further comprising:
means for deploying the vessel filter from a lumen of the catheter.
75. The vessel filter implant apparatus according to claim 74 further comprising:
means for positioning the elongated catheter within a blood vessel in a patient's body to deploy the vessel filter.

76. The vessel filter implant apparatus according to claim 73 further comprising:
a pusher-wire slidably disposed within a lumen of the elongated catheter;
means for preventing the pusher-wire from rotating axially in the lumen of
the elongated catheter.
77. The vessel filter implant apparatus according to claim 76 further comprising:
means for securing the vessel filter to a distal end of the pusher-wire.
78. The vessel filter implant apparatus according to claim 73 further comprising:
means for centering the distal end of the elongated catheter within a blood
vessel.



1/17

FIG. 1

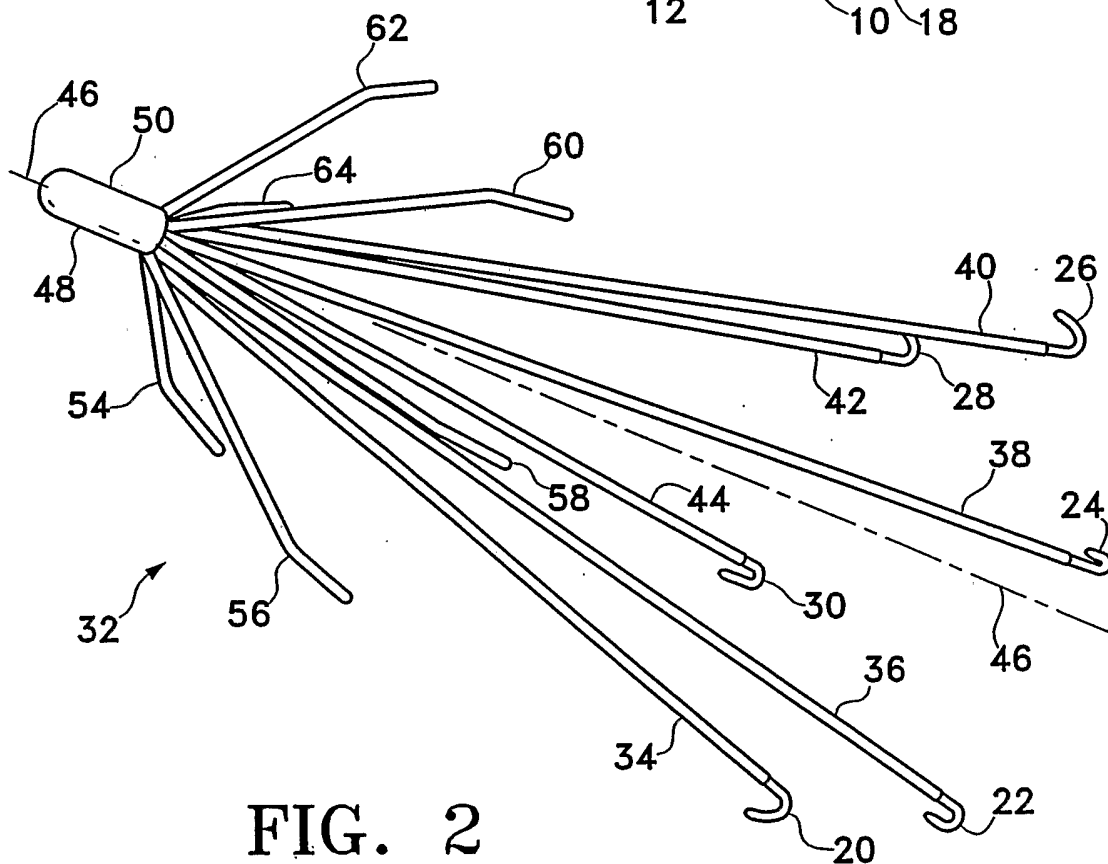
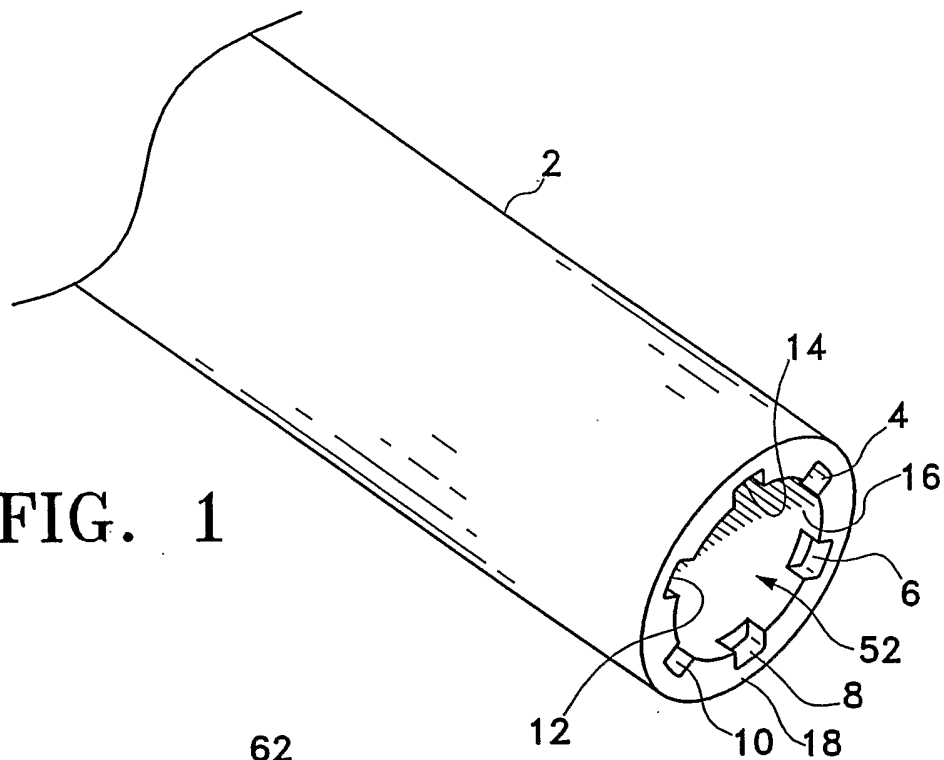

FIG. 2



┌

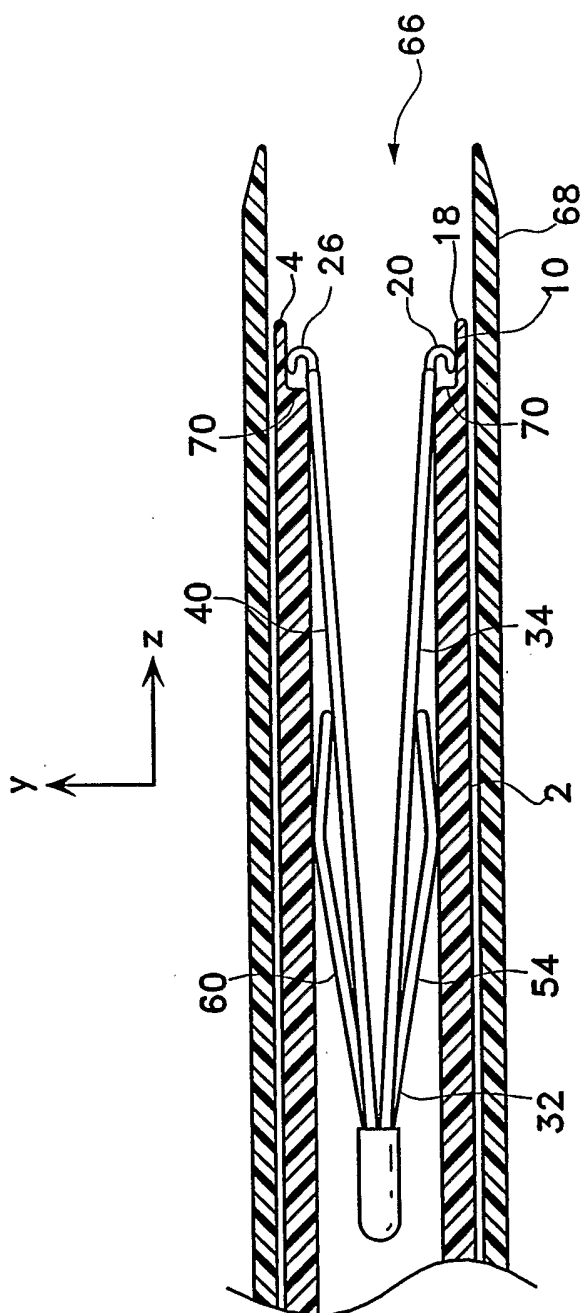

FIG. 3

└

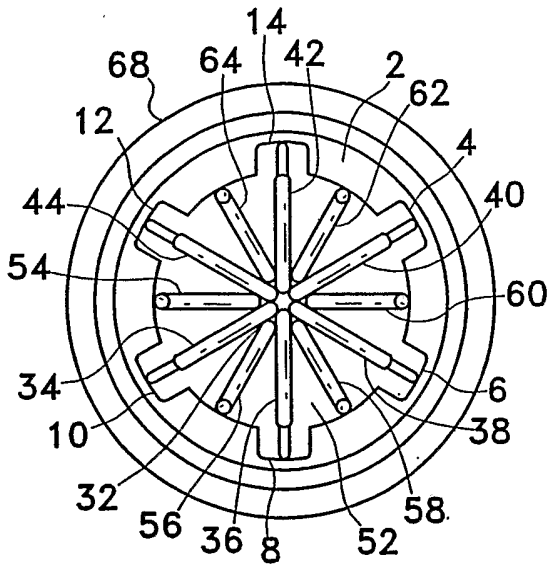

FIG. 4A

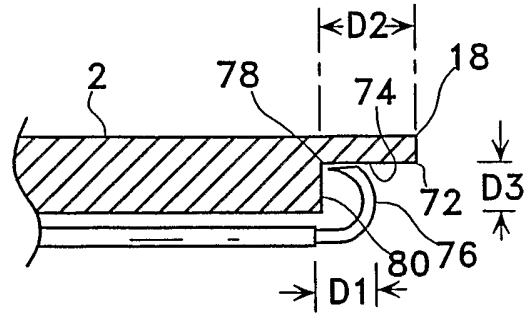

FIG. 4B

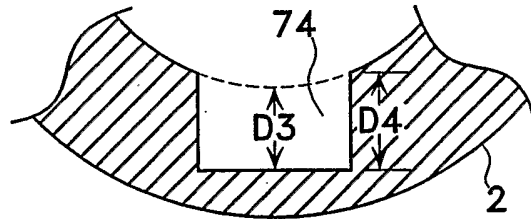

FIG. 4C

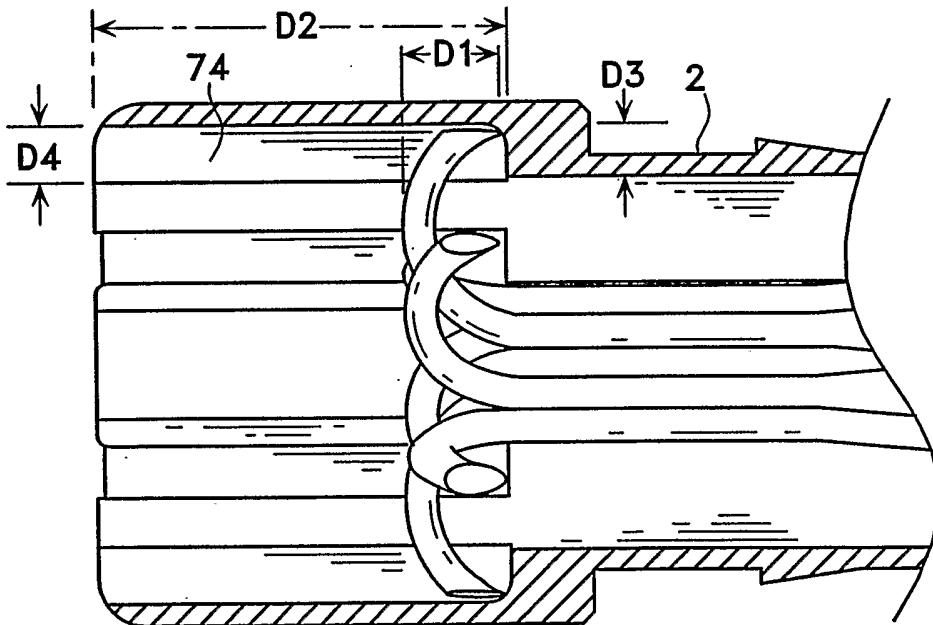

FIG. 4D

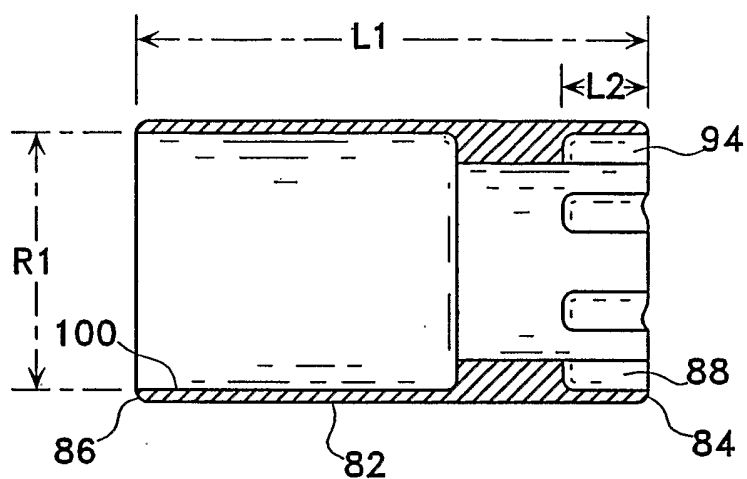

FIG. 5A

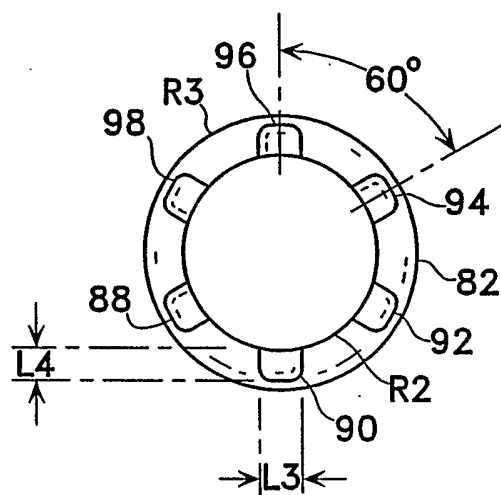

FIG. 5B

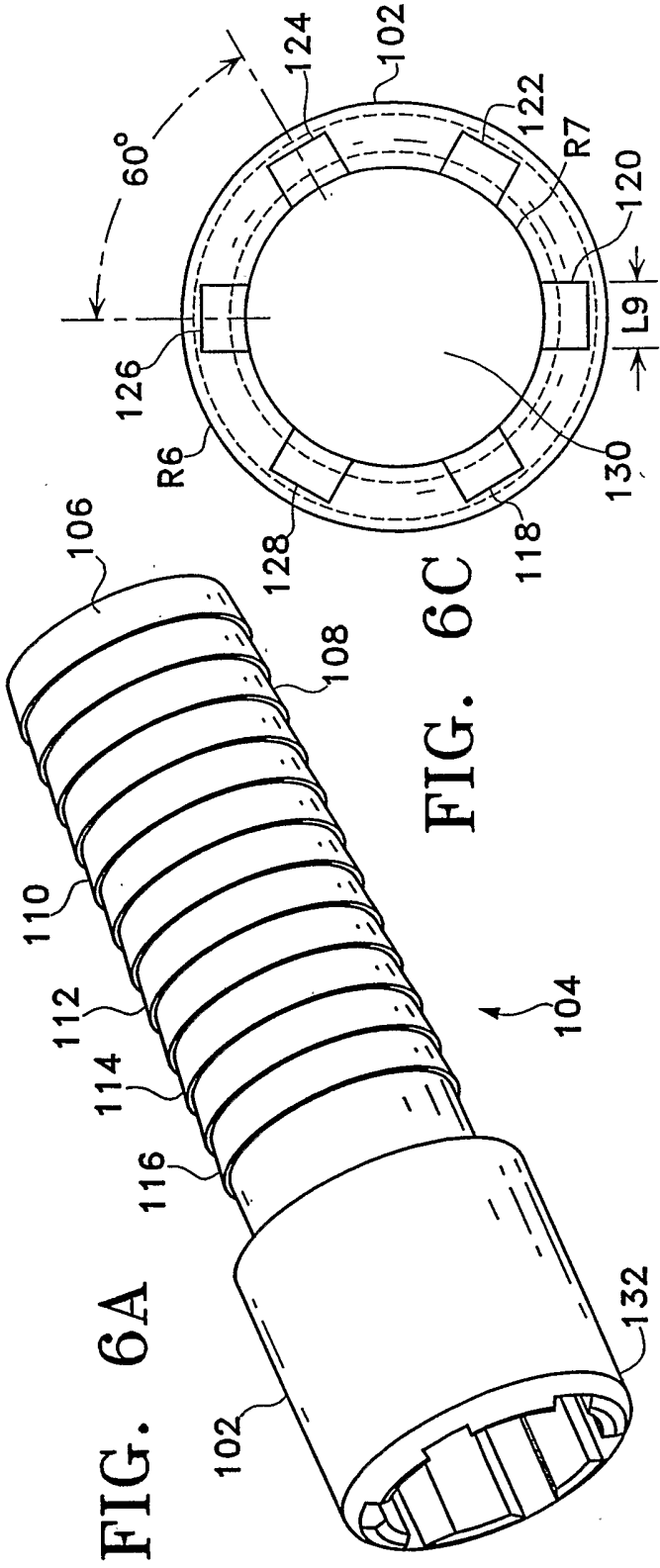

FIG. 6C

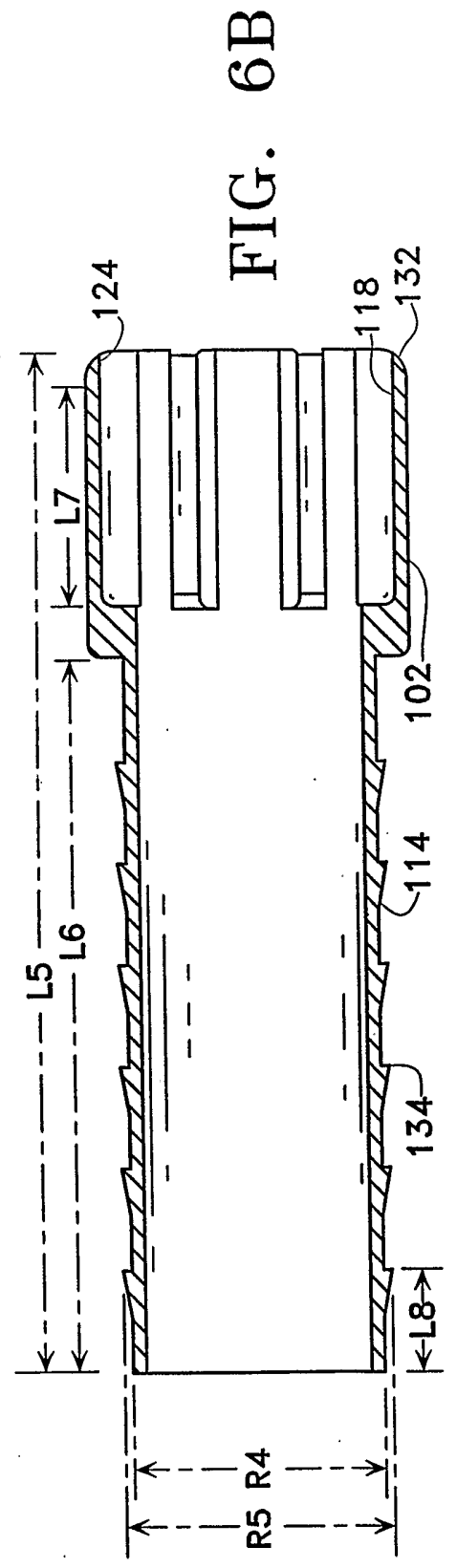
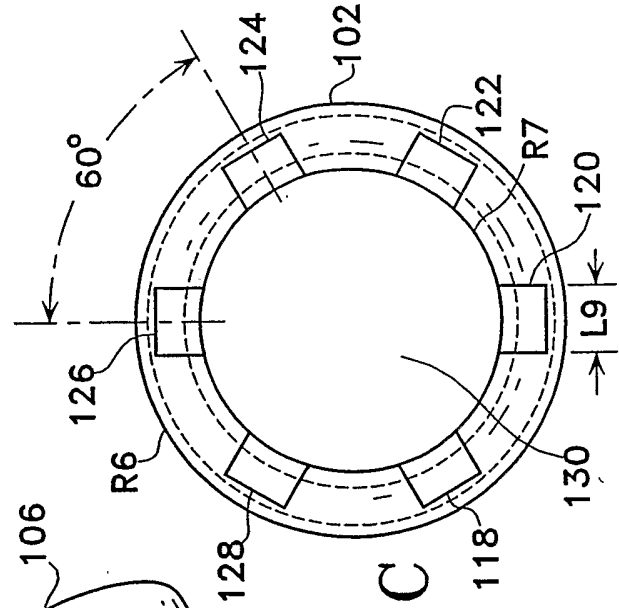

FIG. 6B



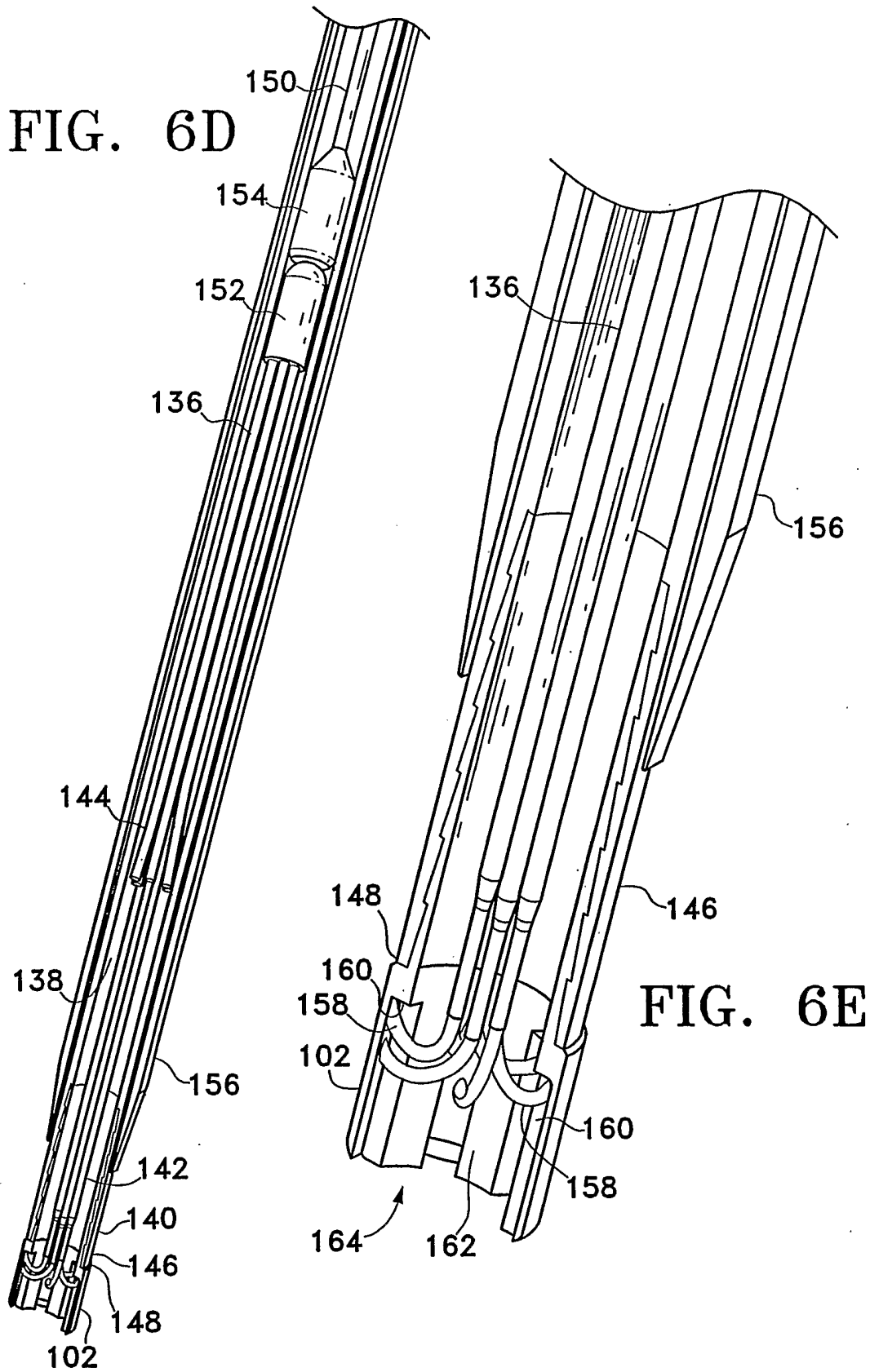

FIG. 6D

FIG. 6E

7/17

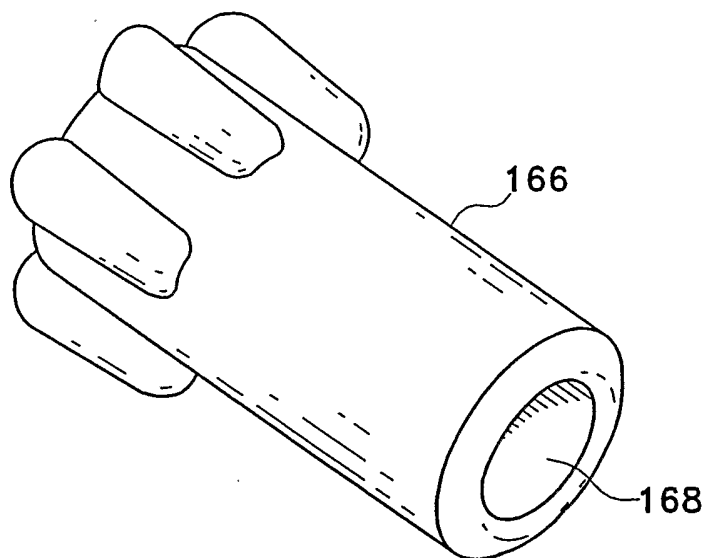

FIG. 6F

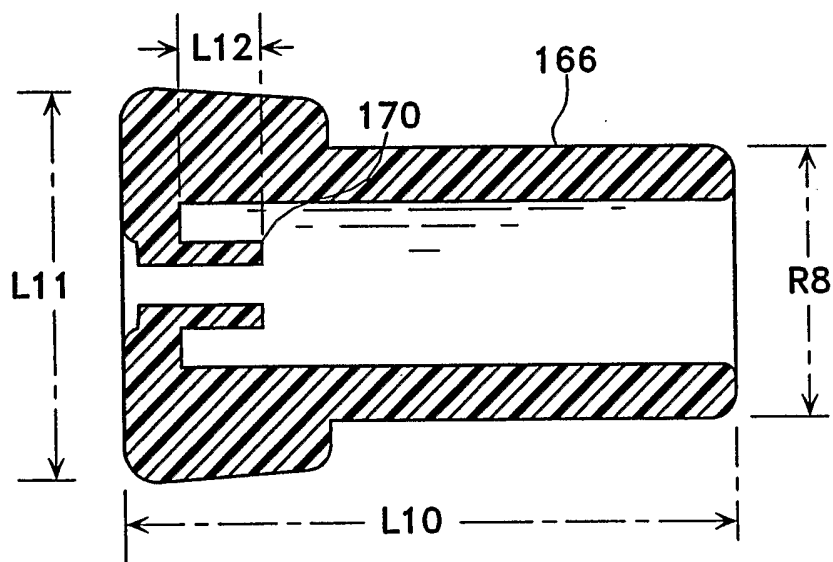

FIG. 6G



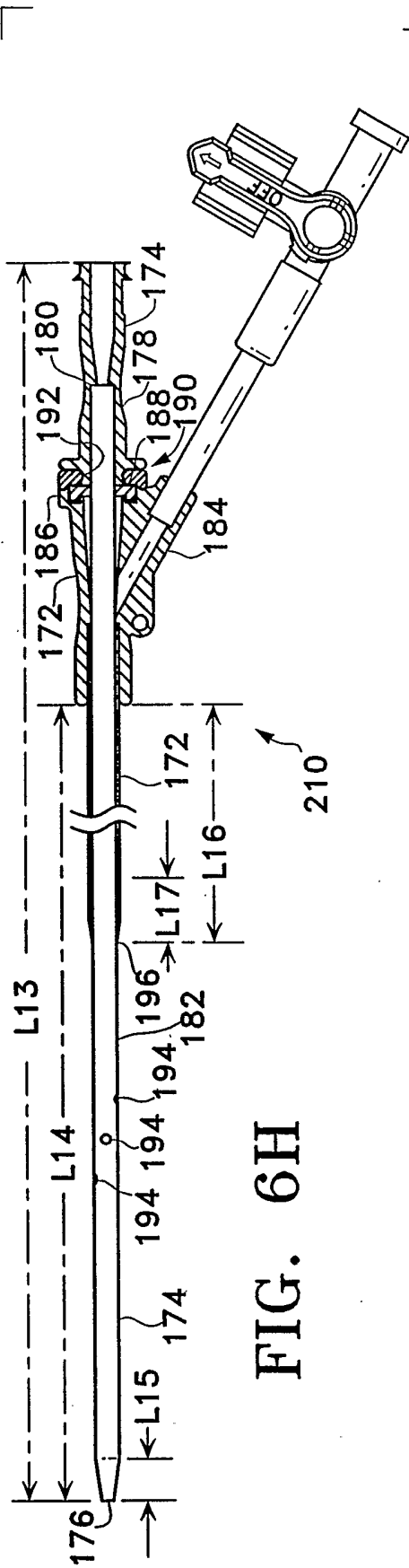

FIG. 6H

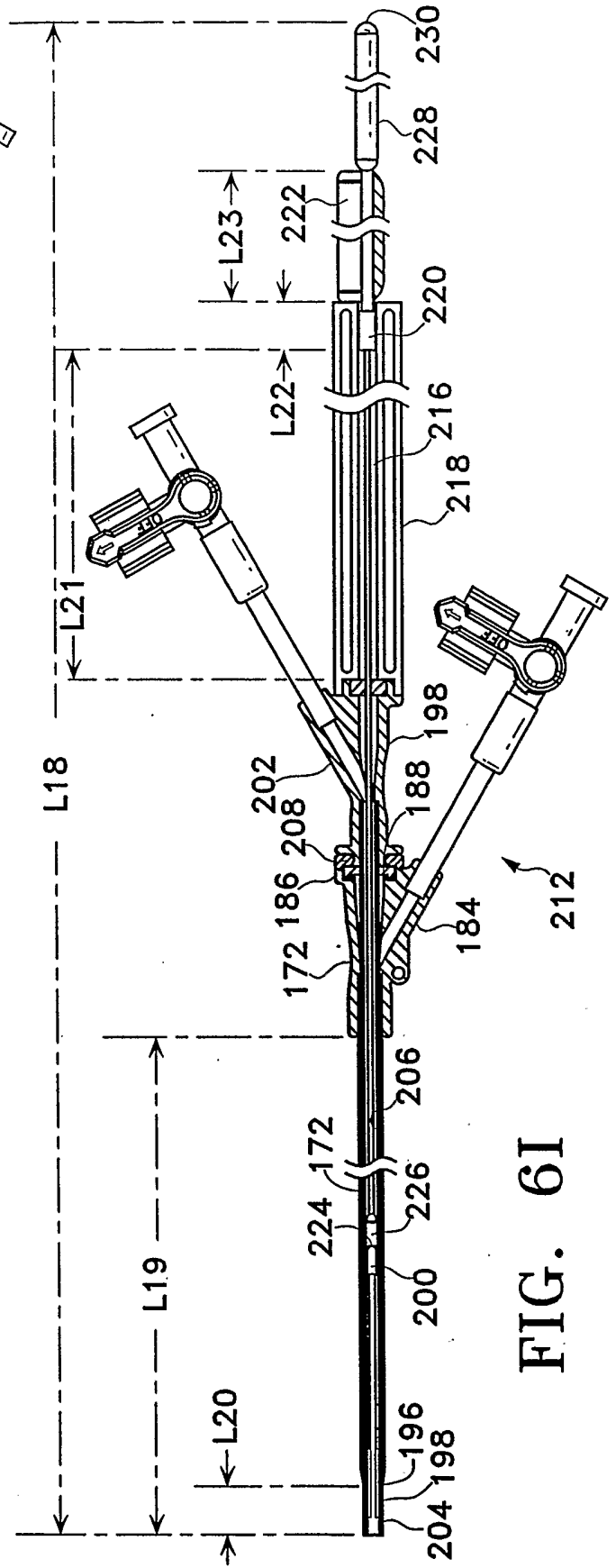

FIG. 6I

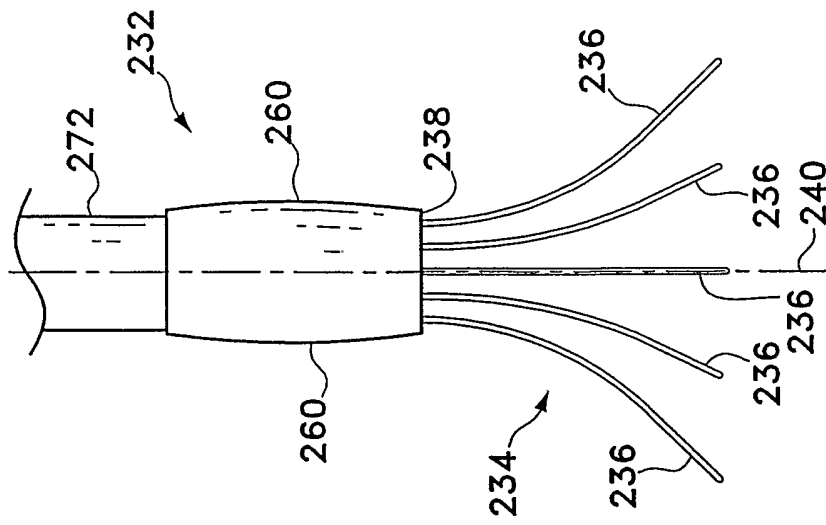

FIG. 7B

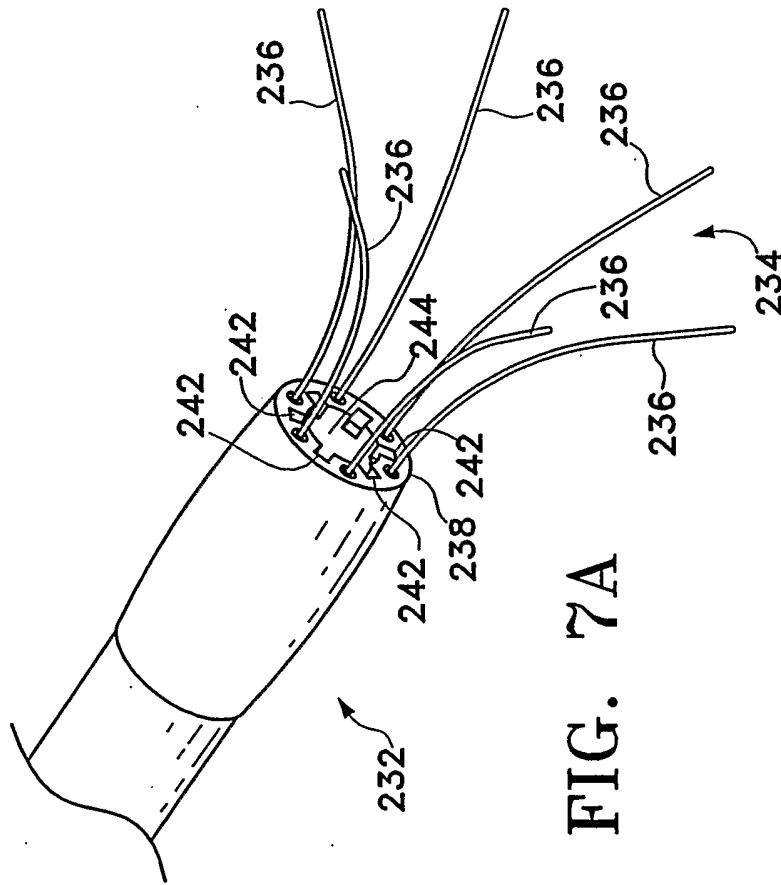

FIG. 7A



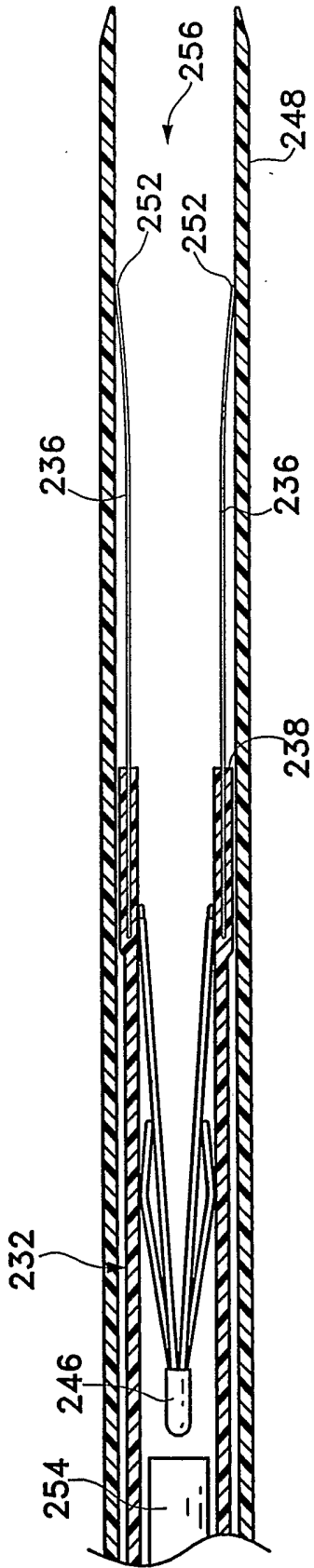

FIG. 7C

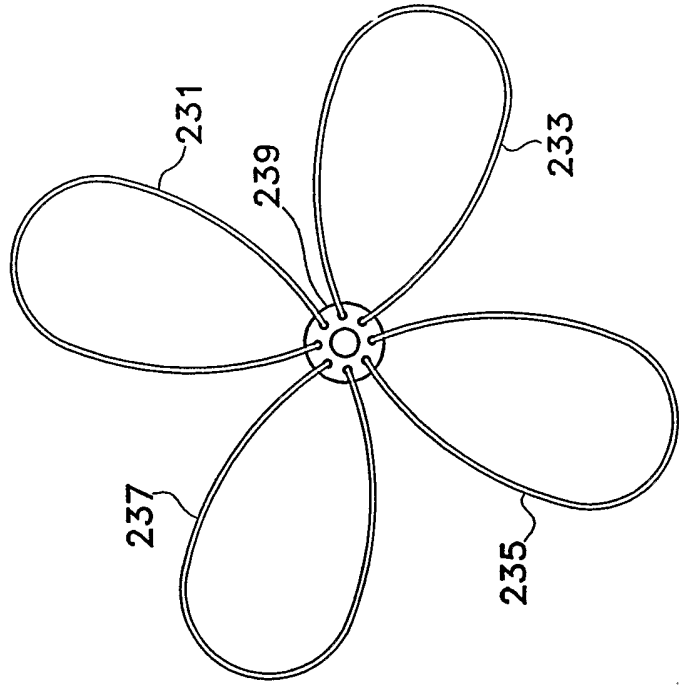

FIG. 7D



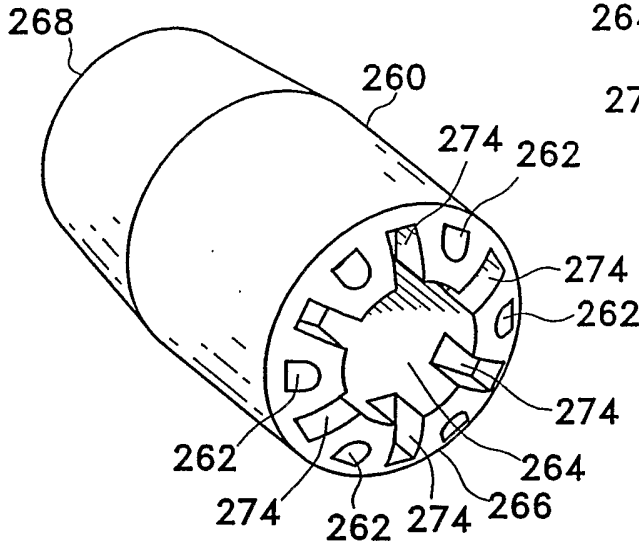

FIG. 8A

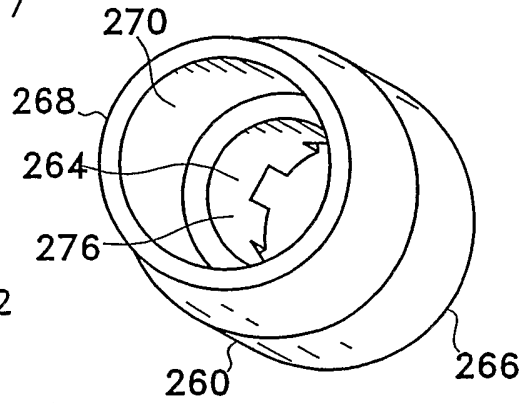

FIG. 8B

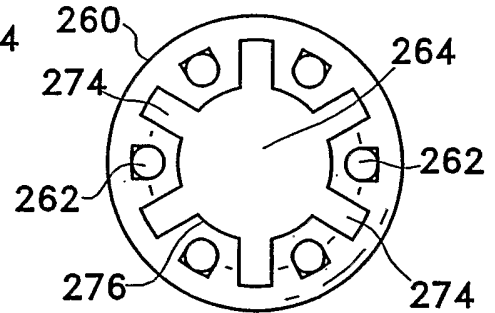

FIG. 8C

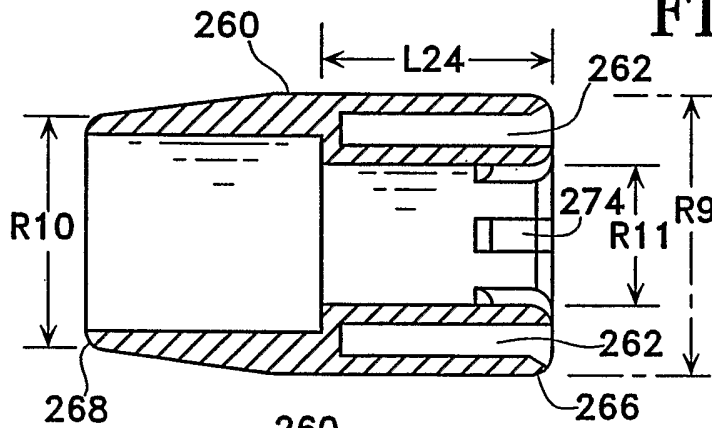

FIG. 9A

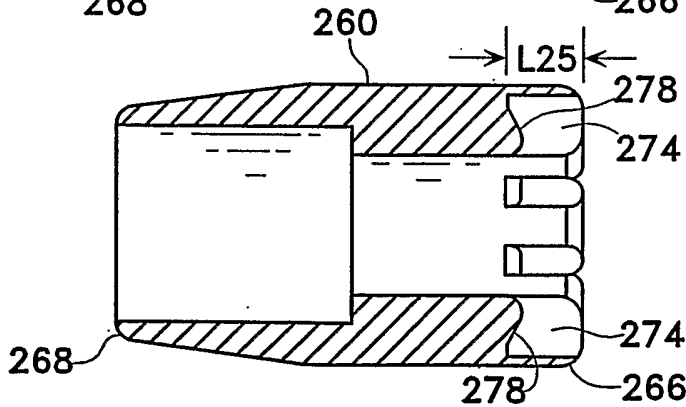

FIG. 9B

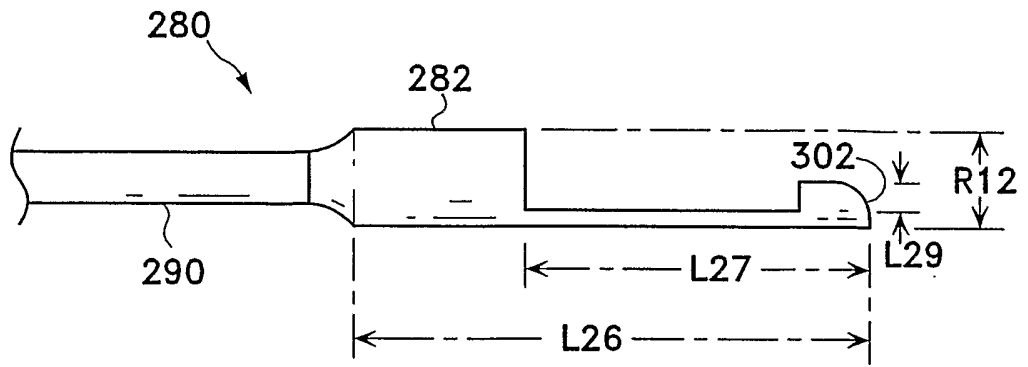

FIG. 10A

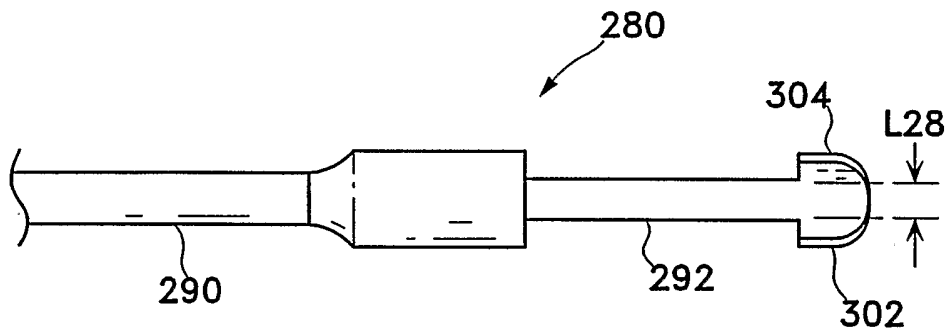

FIG. 10B

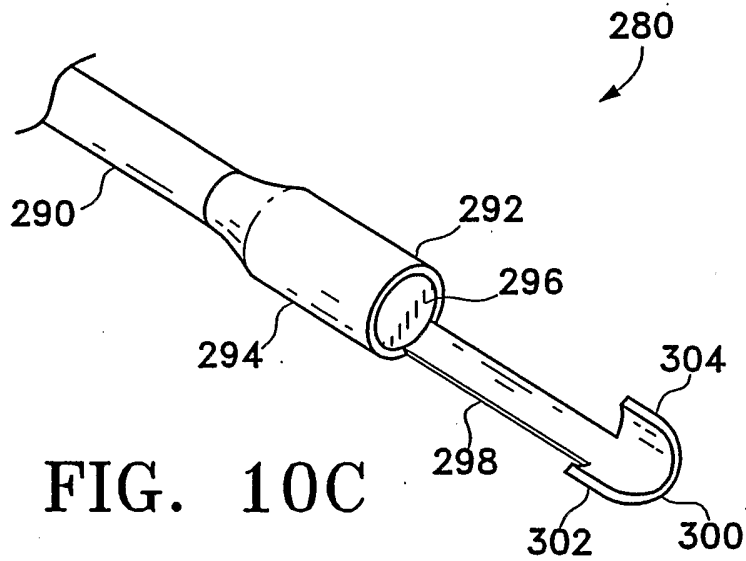

FIG. 10C



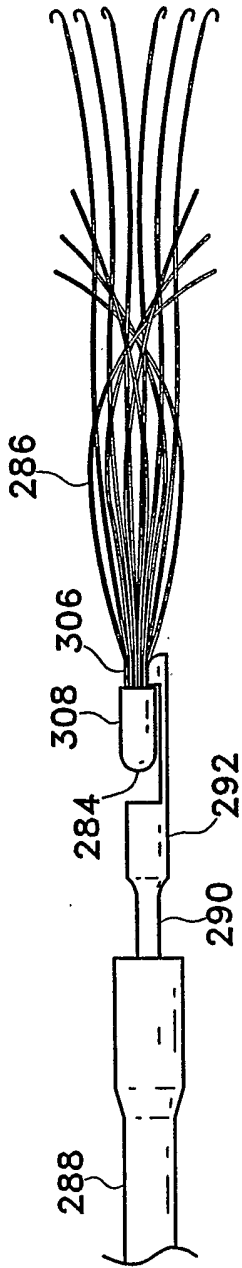

FIG. 11

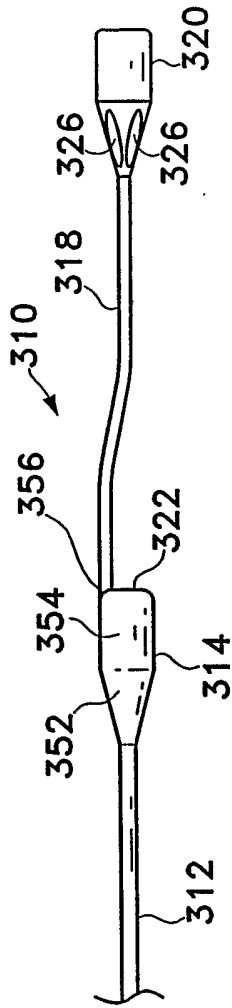

FIG. 12

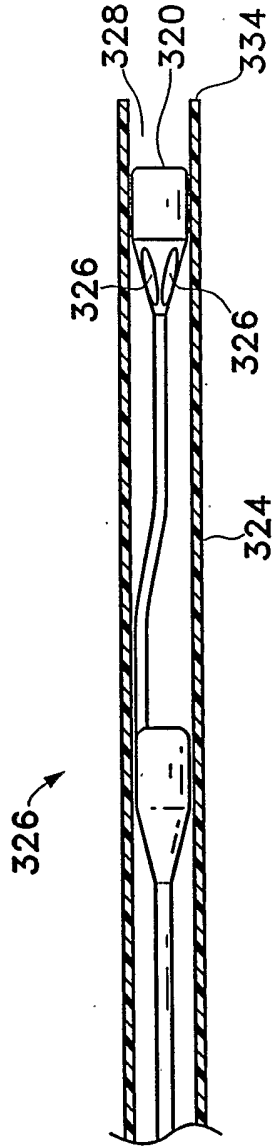

FIG. 13



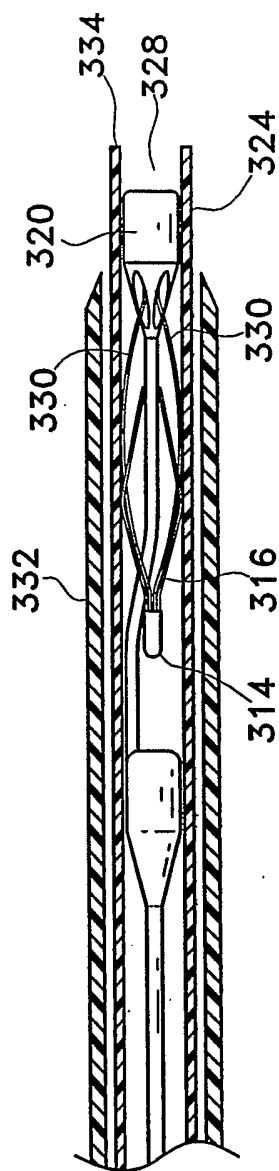

FIG. 14A

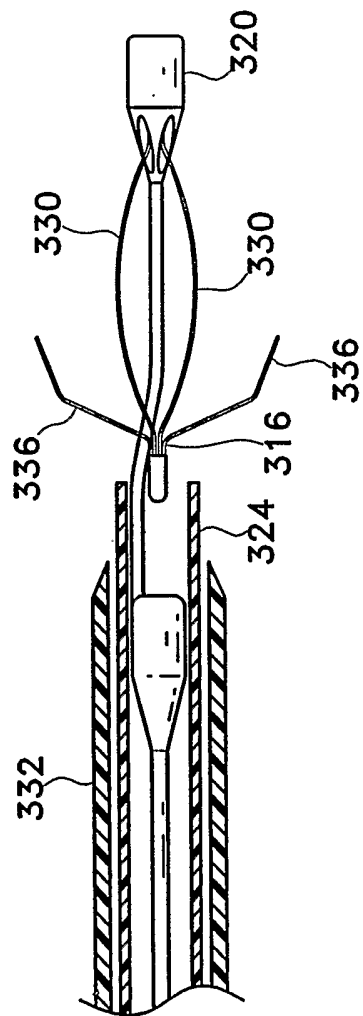

FIG. 14B





15/17

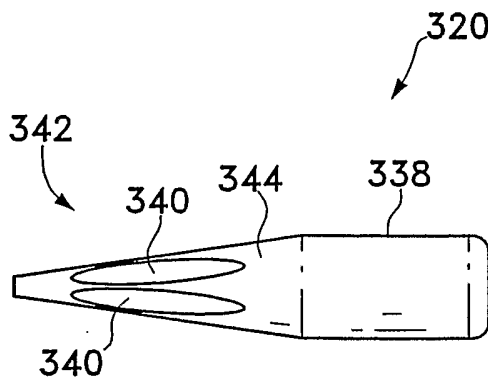

FIG. 15A

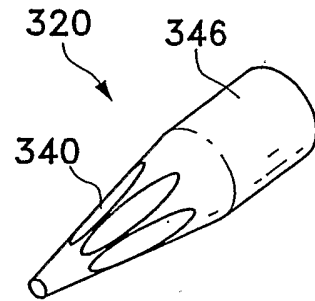

FIG. 15B

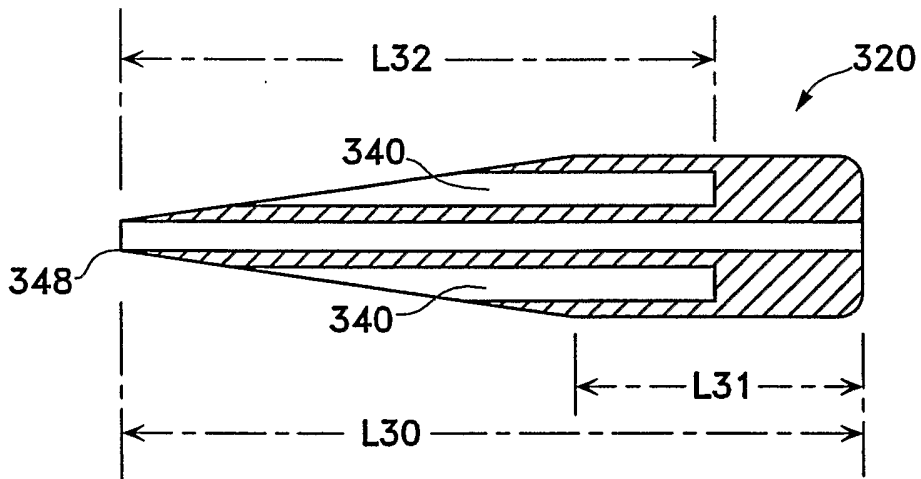

FIG. 15C

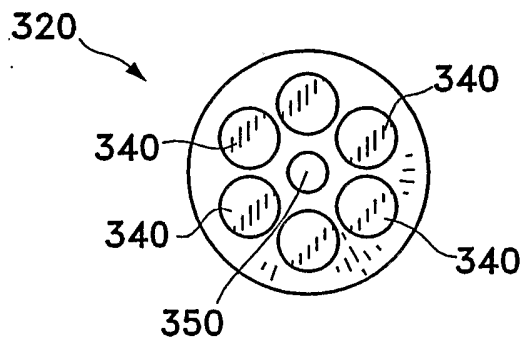

FIG. 15D



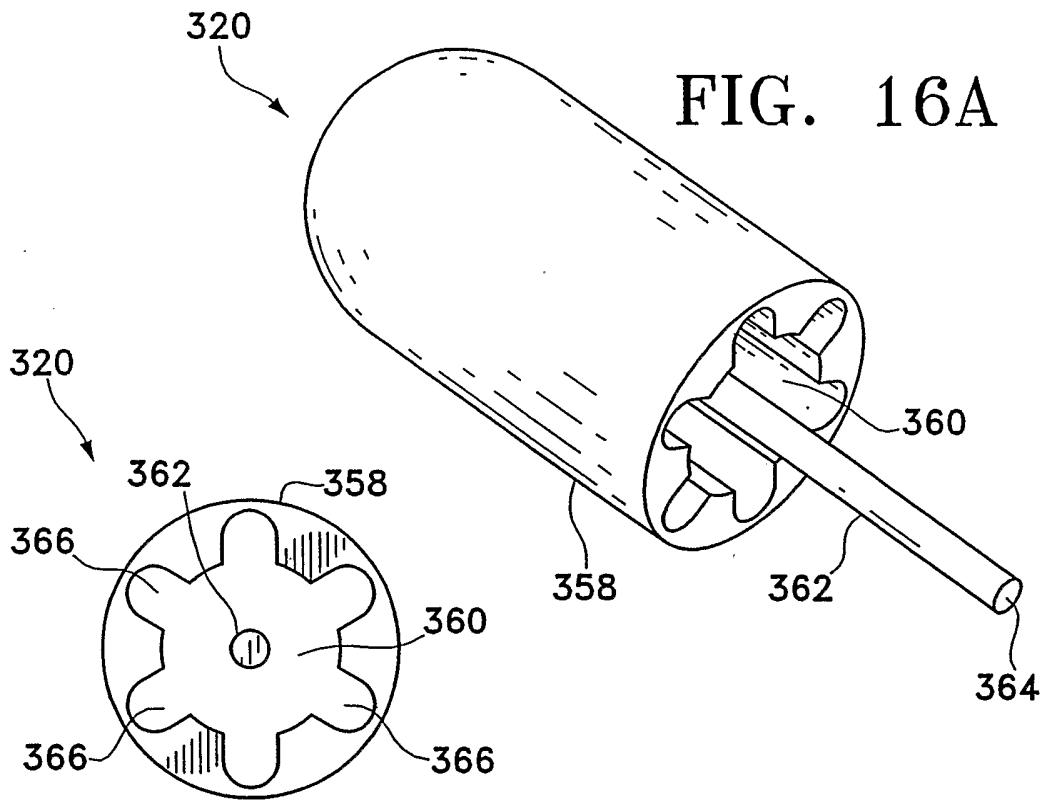
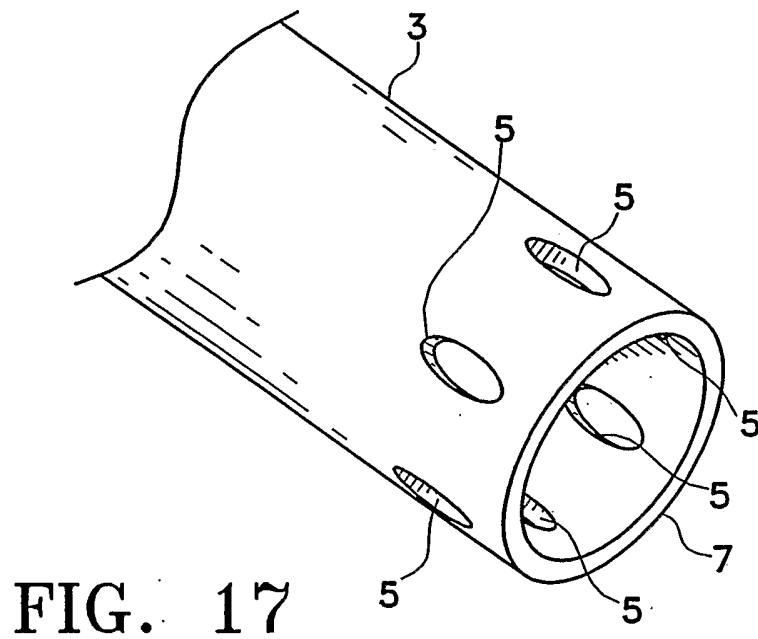

FIG. 16B



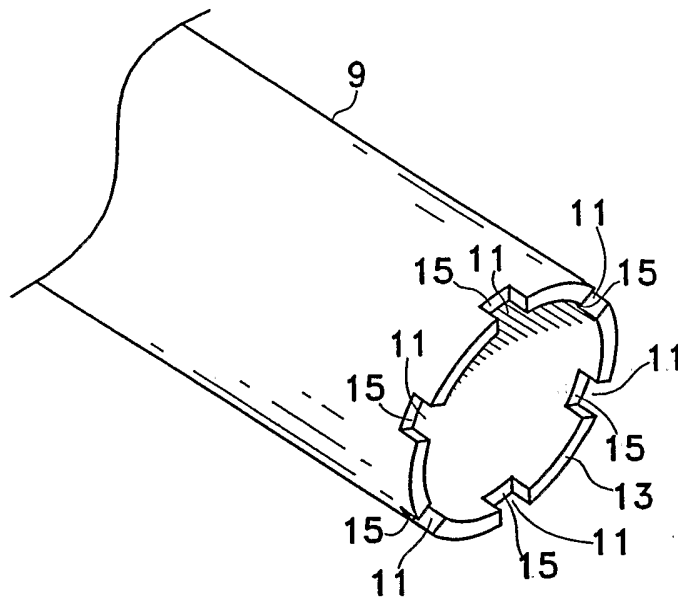

FIG. 18

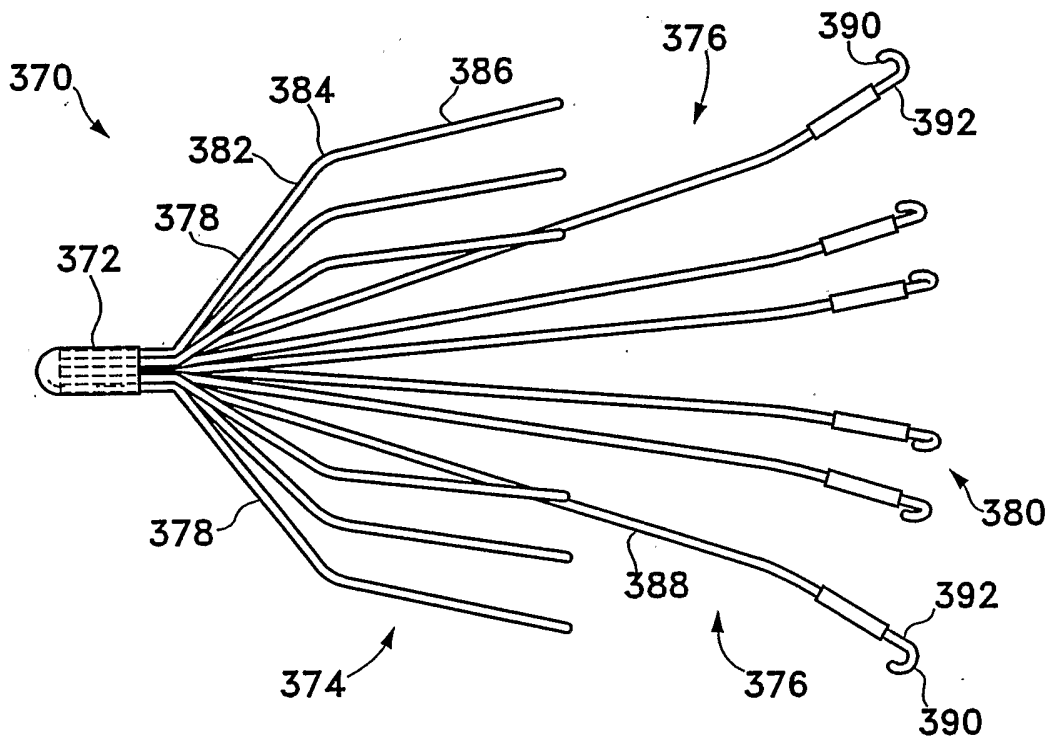

FIG. 19