

(No Model.)

E. ROYCE.
CUTTING APPARATUS.

No. 353,233.

Patented Nov. 23, 1886.

Fig. 1.

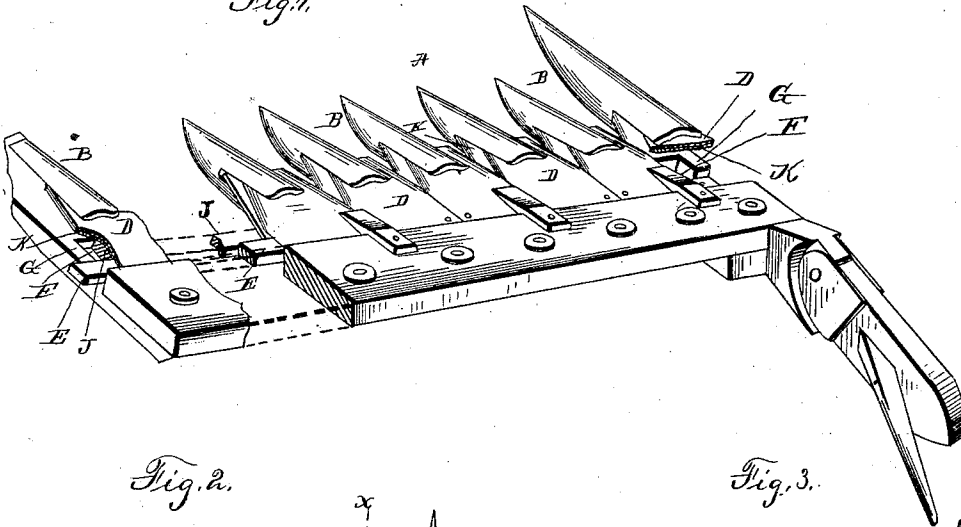

Fig. 2.

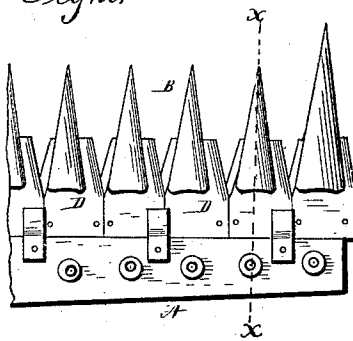

Fig. 3.

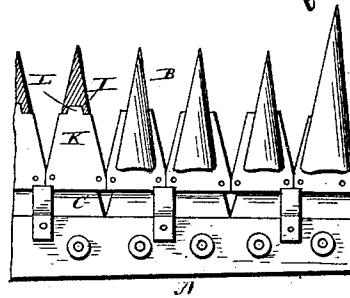

Fig. 4.

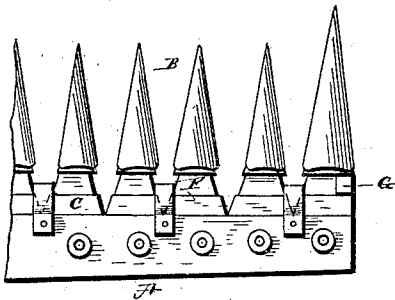

Fig. 5.

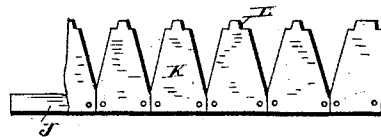
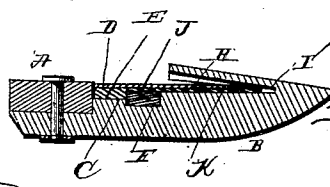

Fig. 6.



WITNESSES

J. L. Durand
Richard Stanton

Ezra Royce,
INVENTOR

By Louis Baggerly
Attorney

UNITED STATES PATENT OFFICE.

EZRA ROYCE, OF PALISADE, DAKOTA TERRITORY.

CUTTING APPARATUS.

SPECIFICATION forming part of Letters Patent No. 353,233, dated November 23, 1886.

Application filed February 15, 1886. Serial No. 191,994. (No model.) Patented in Canada June 1, 1886, No. 24,204.

To all whom it may concern:

Be it known that I, EZRA ROYCE, a citizen of the United States, and a resident of Palisade, in the county of Minnehaha and Territory of Dakota, have invented certain new and useful Improvements in Cutting Apparatus; and I do hereby declare that the following is a full, clear, and exact description of the invention, which will enable others skilled in the art to which it appertains to make and use the same, reference being had to the accompanying drawings, which form a part of this specification, and in which—

Figure 1 is a perspective view of my improved sickle-bar. Fig. 2 is a plan view of the same. Fig. 3 is a plan view of the sickle-bar with the cutter-bar removed. Fig. 4 is a similar view with the lower or rigid cutter-bar removed. Fig. 5 is a plan view of the rigid cutter-bar; and Fig. 6 is a vertical cross-section on line *x x*, Fig. 2.

Similar letters of reference indicate corresponding parts in all the figures.

My invention has relation to sickle-bars for harvesters, reapers, and mowers; and it consists in the improved construction and combination of parts of a sickle-bar in which the blades, which are secured to the guards or fingers, are secured at their inner ends to a bar similarly to the cutter-blades, which bar rests in a groove in the finger-bar, so that after removing the cutter-bar for the purpose of sharpening the cutter-blades the lower or rigid cutter-bar may be removed from the finger-bar and have its blades sharpened, as hereinafter more fully described and claimed.

In the accompanying drawings, the letter A indicates the sickle-bar or finger-bar, which is provided with the usual guards or fingers, B, and which is formed with the usual groove, C, for the cutter-bar, the cutters D of which bar are secured to the bar E in the usual manner, and are of the usual construction. Each guard or finger B is further provided with a groove or notch, F, in front of and below the groove C, except the outer or end guards, in each of which the groove does not extend entirely across it, but leaves the outer portions solid, forming a stop or shoulder, G, in each outer finger. Each of the guards is also provided with the ordinary slots, H, the forward por-

tions of which are provided with recesses I, of less width than the ends of the slots.

The bar J, upon which the lower cutters, K, are secured, fits and rests in the grooves F, with its ends bearing against the stops or shoulders G G, and the forward ends of the lower or rigid cutter-blades are formed with lips or tongues L, which will fit into the recesses in the fingers, retaining the blades K in their position. It will thus be seen that the reciprocating cutter-bar may be slid out through its groove in the usual manner, whereupon the lower rigid cutter-bar may be pushed up out of its groove back into the groove for the reciprocating cutter-bar, the tongues of the lower cutter-blades sliding out of their recesses, and the lower cutter-bar with its blades may now be slid out to one side in the same manner as the reciprocating cutter-bar and be sharpened or repaired, as it is desired. By having the lower cutter-blades secured in this manner the necessity of removing one of the guards and of thereupon removing the cutter-blade and inserting another by riveting it upon the finger is avoided, and the lower cutter-blades may be sharpened and repaired in the same manner as the cutter-blades upon the reciprocating cutter-bar.

The tongues at the outer ends of the lower cutter-blades serve to prevent any lateral displacement of the outer ends of the lower cutters, and the rear or inner ends of the cutter-blades, being secured to the bar, which is prevented from lateral displacement by the shoulders at the ends of the groove, and which is held in place by the reciprocating cutter-bar, will be prevented from being displaced, so that the lower cutters are as securely fastened to the finger-bar as if they were riveted to the fingers, and at the same time are more conveniently secured for repairing or sharpening.

It will further be seen that by having the notches or grooves for the stationary bar below the groove for the reciprocating bar the stationary bar cannot be forced back against the reciprocating one, thus tending to bind it and cause it to run harder, as would be the case if the bottoms of the grooves were on a level, as has been the case with devices of this kind.

The shape of the fingers, as well as of the

lower and upper cutters and their fastenings to the bars, may be changed as desired without changing the spirit of my invention, which is applicable to any style of sickle-bar and to any style of cutters.

Having thus described my invention, I claim and desire to secure by Letters Patent of the United States—

In a cutting apparatus, the combination of a finger-bar provided with guard-fingers, each of said fingers being provided with a groove in front of and extending below the level of the

cutter-bar groove, the groove in each of the end guards not extending entirely across them, a bar in said groove having a series of cutters secured thereto, and a reciprocating bar having cutters secured to it.

In testimony that I claim the foregoing as my own I have hereunto affixed my signature in presence of two witnesses.

EZRA ROYCE.

Witnesses:

W. H. RIDDELL,
JOHN STEINMETZ.