



EUROPEAN PATENT APPLICATION

Application number : **91307220.3**

Int. Cl.⁵ : **E04F 13/08, E04B 2/88**

Date of filing : **06.08.91**

Priority : **07.08.90 JP 209702/90**
05.07.91 JP 165578/90

Date of publication of application :
12.02.92 Bulletin 92/07

Designated Contracting States :
DE ES FR GB IT

Applicant : **Kajima Corporation**
2-7 Moto Akasaka 1-chome Minato-ku
Tokyo 107 (JP)
Applicant : **FUJI SASSHI CORPORATION**
135 Nakamaruko, Nakahara-ku
Kawasaki-shi, Kanagawa-ken 211 (JP)
Applicant : **KABUSHIKI KAISHA INAX**
5-1 Koiehonmachi, Tokoname-shi
Aichi-ken 479 (JP)
Applicant : **YAMAZAKI SANSHO KABUSHIKI**
KAISHA
12-1 Kameido 6-chome
Koutou-ku, Tokyo 136 (JP)

Inventor : **Saito, Makoto c/o Kajima Corp.**
2-7 Motoakasaka 1-chome
Minato-ku Tokyo 107 (JP)
Inventor : **Miyamoto, Kiyoshi c/o Fuji Sasaki**
Corp.
135 Nakamaruko Nakahara-ku
Kawasaki-shi, Kanagawa Ken 211 (JP)
Inventor : **Ito, Tetsuya c/o Kabushiki Kaisha**
Inax
5-1 Koiehonmachi
Tokoname-shi Aichi-ken 479 (JP)
Inventor : **Yoshioka, Hideo**
17-16 Oshima 7-chome
Koutu-ku, Tokyo 136 (JP)

Representative : **Hackett, Sean James**
Marks & Clerk 57-60 Lincoln's Inn Fields
London WC2A 3LS (GB)

Tile-supporting tool, tiled wall structure and tiled curtain wall.

Tile-supporting tools (1,2), a tiled wall structure and a tiled curtain wall (8) are described. A plurality of tiles (3) are set by installing tile-supporting tools (1,2) at constant intervals and by engaging concave portions (3a, 3a) of the tiles (3) with tile-holding portions (1b, 2b) formed in the tile-supporting tools (1,2). The tile-supporting tools (1) comprise a pair of arms, having the tile-holding portions (1b) formed therein, which arms extend from a channel having a generally rectangular or triangular cross-section. The tile-supporting tool (2) has a single arm, also having a tile-holding portion (2b) extending from a generally "L" shaped member. Each of the tile supporting tools (1,2) has a resilient character so that the tiles (3) can be secured between tools (1,2) by way of a snap-fit.

FIG. 6

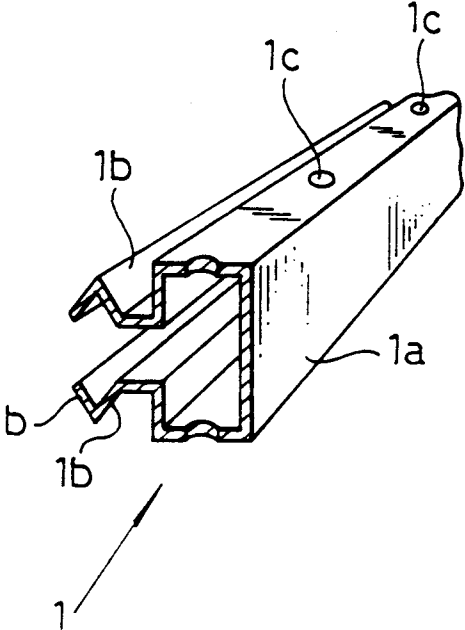
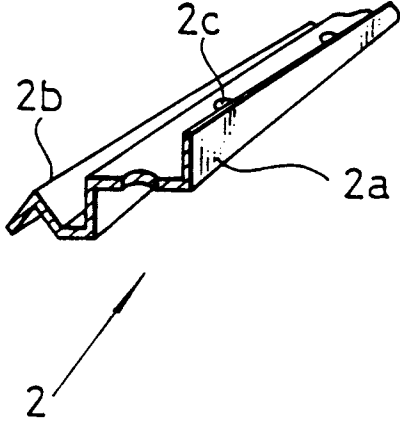

FIG. 7



Technical Field:

This invention relates to a tile-supporting tool, a tiled wall structure and a tiled curtain wall.

Background Art:

In general, in cases where the external walls of buildings are finished with tiles and stones, it is not only easy to clean them but also their appearance looks good. Therefore, there are many cases where the external walls of recently constructed buildings are finished with tiles.

A method of attaching such tiles and stones involves adhering the tiles and stones piece by piece to frame surfaces by means of adhesive mortar 13 (refer to Figure 12). However, as this is time consuming, such tiles and stones have been premounted on pre-fabricated substrates in a factory or the like. One such substrate (will designate as PC plates 12 thereafter) forming a precast concrete exterior plate is shown in Figure 13.

It is, however, necessary to ensure that the PC plates have enough strength to resist cracking due to dry shrinkage and wind pressure and/or earthquake, and therefore, it is necessary to make the PC plates thick. As a result, there is the problem that the PC plates become heavy, making it not only difficult to handle their transportation and installation, but also increasing the corresponding material expense.

In addition, if there are mistakes in the colour combinations of the exterior tiles, stones or the like, it is necessary to re-cover them. However, as the exterior materials are adhered monolithically, this operation is extremely troublesome, and accidents due to the deterioration of adhering materials may result.

Furthermore, it is easy to remove dirt from a prior art tiled wall (refer to Figure 12) for a certain period of time immediately after installation, but it becomes more difficult to remove the dirt with the passage of time.

Another problem is that the tiles and stones often become dislodged due to the reduction of the adhesive strength of the adhesive mortar caused by the freezing of rain water absorbed by the adhesive mortar. This leads to the necessary requirement of total repair or partial replacement of tiles and stones.

For total replacement of tiles, it is, however, necessary according to the prior art firstly to peel off all of the existing tiles and then to set new tiles. This is extremely troublesome.

In addition, when there is only partial replacement of the tiles there is the problem of misregistration and colour mis-matching between old and new tiles.

Furthermore, the stripping of the tiles at high places is dangerous to the persons passing below.

The present invention is proposed so as to resolve such problems in the prior art, and an object

of the present invention is to provide a tile-supporting tool, a tiled wall structure and a tiled curtain wall which facilitates easier installation and replacement of tiles and stones with security.

5

Disclosure of the Invention:

For the purpose of attaining the above-mentioned object, the tile-supporting tool according to the present invention has tile-holding portions approximately in parallel with both ends of the opening of a base in an approximately lip channel shape in cross-section. The tile-holding portions have an approximately V-letter or U-letter shape in cross-section, and are formed together with the channel so as to have elasticity or resilience. In an alternative arrangement, the tile-holding portion protrudes the tile-holding portion to the top end of a rise in the base formed in a L-letter shape in cross-section. The tile-holding portion has an approximately V-letter or U-letter shape in cross-section, and is formed while having elasticity on the whole.

The tiled wall structure according to the present invention is constructed, for example, by setting the tile-supporting tool on the wall surface of a concrete wall at a constant interval and by engaging a concave portion of the tile with the tile-holding portion of the tile-supporting tool for attaching a plurality of tiles.

In addition, the tiled curtain wall according to the present invention is constructed by attaching a plurality of tiles by installing a steel frame, which is composed in a rectangular lattice frame shape and has a water-proof plate composed of thin metal plates and stuck to the outdoor side, between slabs of upper and lower floors, setting the tile-supporting tool to the outdoor side of the steel frame at a constant interval and engaging the concave portion of the tiles to the tile-holding portion of the tile-supporting tool.

Furthermore, in the tiled wall structure and the tiled curtain wall, a joint member formed in a rectangular or circular shape in cross-section is interposed between the tile-holding portions of each tile-supporting tool and between left and right tiles.

Best Mode for Executing the Invention:

For explaining the present invention in more detail, the description will be given with reference to the attached drawings.

50

Brief Description of the Drawings:

Figure 1 is a partial front view of a tiled wall and a tiled curtain wall;

Figures 2, 3 and 4 are partial vertical sectional views showing the structure of the tiled wall, respectively;

Figure 5 is a partial vertical sectional view show-

ing the structure of the tiled curtain wall;
 Figures 6 and 7 are partial perspective views of a
 tile-supporting tool, respectively;
 Figure 8 is a perspective view of a tile;
 Figures 9 and 10 are vertical sectional views
 showing the structure of a joint portion of the tiled
 wall and the tiled curtain wall, respectively;
 Figure 11 is a sectional view showing another
 embodiment of the tile-supporting tool;
 Figure 12 is a partial vertical sectional view show-
 ing the structure of a prior art tiled wall; and
 Figure 13 is a vertical sectional view of a prior art
 tile-placed PC plate.

In a tiled wall structure embodying the present
 invention, tile-supporting tools 1, 2 as shown in Fig-
 ures 6 and 7 and a tile 3 as shown in Figure 8 are used.

The tile-supporting tool 1 is composed of tile-
 holding portions 1b, 1b. A base 1a is formed in a lip-
 channel shape, and in its upper and lower flange
 portions, a plurality of drain holes 1c are formed at a
 constant interval in its longitudinal direction. The tile-
 holding portions 1b, 1b protrude from arms which
 extend from a side wall of the channel. In use, the tool
 will be disposed horizontally. The tile-holding portions
 are formed in an approximately V-letter or U-letter
 shape in cross-section so as to be directed outwardly
 with respect to each other.

On the other hand, the tile-supporting tool 2 is
 composed of a base 2a and a tile-holding portion 2b.
 The base 2a is formed in an approximately L-letter
 shape in cross-section, and in its rise portion, a
 plurality of drain holes 2c are formed in its longitudinal
 direction at constant intervals. The tile-holding portion
 2b extends from a flange portion of the base 2a. The
 portion 2b is formed in an approximately V-letter or U-
 letter shape in cross-section similar to the tile-holding
 portion 1b.

In addition, the base 1a and the tile-supporting
 portion 1b, 1b in the tile-supporting tool 1 and the base
 2a and the tile-holding portion 2b in the tile-supporting
 tool 2 are integrally formed from metallic plates of
 stainless steel or aluminium or synthetic resin mat-
 erial, and simultaneously, it has a required amount of
 an elastic force (spring force).

A tile 3 is formed in a rectangular plate shape,
 longer in its horizontal or vertical direction, and formed
 with concave portions 3a, 3a having an approximately
 V-letter or U-letter shape in cross-section, corre-
 sponding to the tile-holding portions 1b, 2b, and cap-
 able of engaging with the tile-holding portions 1b, 2b.

The tile 3 can be formed by an extrusion molding
 method to precision tolerances so that the concave
 portion 3a formed in the rim of the tile 3 is capable of
 fitting between the tile-holding portions 1b, 2b, of adja-
 cent tile-supporting tools.

In addition, if possible, the concave portions 3a is
 formed not only in both upper and down sides of the
 tile 3, but also in both left and right sides. This enables

lateral fixing of the tile with greater ease.

The tile-supporting tools 1 thus formed are set
 horizontally at constant intervals between the tile-sup-
 porting tools 2, 2 which are installed horizontally at
 uppermost and lowermost positions. The tools are
 supported to a wall by screwing or welding.

The tiles 3 are attached by placing them in a row
 in the longitudinal direction of the tile-supporting tools
 1, 2 between the upper and lower tile-supporting tools
 1, 1, and between the tile-supporting tool 1 at the
 uppermost stage and the bottom end and the tile-sup-
 porting tool 2 at the immediately lower or upper posi-
 tion, to construct the entire tile wall (refer to Figures 1
 and 2).

Each of the tiles between the tile supporting tools
 1, 1 and between those 2, 2 are fixed, respectively, by
 inserting the tile-holding portions 1b, 2b of the tile-
 supporting tools 1, 2 into the upper and lower concave
 portions 3a, 3a of the tile 3.

In such a case, as the tile-supporting tools 1 and
 2 have a certain large elastic force or resilient charac-
 ter the tile 3 is firmly held between the upper and lower
 tile-holding portions 1b, 2b.

Figures 3, 4 and 5 show a tiled wall structure
 using the tile-supporting tools 1, 2 and the tiles 3.

Of all these figures, Figure 3 shows the appli-
 cation of such a structure to a reinforced concrete
 wall. A plurality of tile-supporting tools 1 and 2 are
 directly attached to the wall surface 4 by anchor bolts
 5, and the entire tile wall is constructed by inserting a
 plurality of tiles 3 between the tile-holding portions 1b,
 2b of the tile-supporting tools 1 and 2 piece by piece.

Then, in Figure 4, the tile-supporting tools 1 and
 2 are not directly attached to the wall surface 4, but a
 steel frame 6 is attached to the wall surface 4 as a
 base material. A plurality of tile-supporting tools 1 and
 2 are fixed to this steel frame 6 by setting bolts 7, and
 the entire tile wall is constructed by inserting a
 plurality of tiles 3 between the tile-holding portions 1b,
 1b of the tile-supporting tools 1 and 2 and between
 those 1b and 2b.

Moreover, the steel frame 6 is constructed by
 assembling left and right vertical frames 6a, 6a, upper
 and lower horizontal frames 6b, 6b and middle frames
 6c, 6c. These are made of lightweight channel steel
 and angle steel and arranged in a vertically orientated
 rectangular lattice frame of required dimension.

Adoption of the embodiments of Figures 3 and 4,
 makes it easier to construct a new tile finish for the
 surface of a reinforced concrete wall as compared
 with the prior art which involves use of adhesive mor-
 tar.

In addition, in the case of repairing a wall finished
 according to an embodiment, a repair can be directly
 carried out on a tile without the need to remove it.
 Therefore, the repair can be done extremely easily.

Furthermore, in the embodiment of Figure 4, if the
 steel frames 6, the tile-supporting tools 1, 2 and the

tiles 3 are assembled in a factory or on site, and then attached to the wall surface 4, it becomes possible to cover wide areas at a time. This results in an increase in installation efficiency.

In the case where a steel frame is to be positioned between the tools and the wall, and the tiles 3 at the uppermost stage and the bottom end are already in position, it is necessary to remove those tiles 3 at the uppermost stage. This is because the tiles 3 at the uppermost stage and the bottom end stand in the way of the steel frame 6, thereby preventing installation of the steel frame 6 to the concrete wall surface 4. The tiles 3 at the uppermost stage should be reset in position after the steel frame 6 is installed.

Figure 5 shows the tiled curtain wall. The curtain wall 8 is constructed by sticking water-proof plates 6d composed of a thin metallic plate to the outdoor side of the steel frame 6 illustrated in Figure 4. The tile-supporting tools 1 and 2 are attached to the outer side of the water-proof plate 6d with screws or by welding. A plurality of tiles 3 are subsequently attached.

The diameters of the left and right vertical frames 6a, 6a, the upper and lower horizontal frames 6b, 6b and the middle frames 6c, 6c of the steel frame 6 and the installation interval of the middle frame 6c of the steel frame 6 are determined on the basis of various design conditions of expected wind pressure or the like.

According to the tiled curtain wall 8, the cladding of external walls can be practiced as soon as they are finished, and therefore, the construction time of the works is shortened.

In any of the embodiments of Figures 3, 4 and 5, the tiles 3 are not completely fixed to the tile-supporting tools 1 and 2, but are merely held between them. Therefore, it is simple to exchange any tile.

Figures 9 and 10 show the structure of a tile joint portion, and a joint member 10 is interposed between the upper and lower tile-holding portions 1, 1b of the respective tile-supporting tools 1 and 2 and between those 2b, 2b. In addition, a design effect is risen by interposing the joint member 11 between the left and right tiles 3, 3.

The joint members 10 and 11 are formed in a circular rod or circular hollow rod shape in cross-section by synthetic resin, synthetic rubber or metal of aluminium or steel.

Furthermore, Figure 11 shows a modification of the tile-supporting tool 1, and the spring force is strengthened by forming the base 1a in a triangle shape instead of an approximately lip channel shape in cross-section.

Industrial Applicability:

As above mentioned, the tile-supporting tool, the tiled wall structure and the tiled curtain wall structure set tiles by means of the tile-supporting tool having a

simple shape without using plaster material such as adhesive mortar, and therefore, they enable to set tiles easily and execute new tile walls with ease.

The tile-holding portion of the tile-supporting tool is also formed in an approximately V-letter or U-letter shape in cross-section, and the concave portions capable of engaging with the tile-holding portions are formed in the upper and lower rim end portions of the tile corresponding to the shapes of the tile-holding portions. Furthermore, as a constant large spring force is given to the tile-supporting tool, the tiles can be set with security.

In case it is necessary to repair an existing tile wall executed by adhesive mortar, embodiments can be applied to the existing tile wall.

In addition, as it is possible to exchange some of the tiles as required, repair by the single exchange of tiles can be practiced.

In the case of exchanging the tiles, the colour matching with the existing tiles can be achieved more easily, and there is no anxiety about the occurrence of any misregistration at all. Therefore, partial repairs can be practiced with security.

Moreover, as a rectangular, circular or circular hollow joint member in cross-section is interposed between the upper and lower tile-holding portions of each tile-supporting tool and between the left and right tiles, its design effect is also extremely high.

Furthermore, in case of using the joint member formed in a circular or circular hollow shape in cross-section from synthetic rubber or the like as a joint member, the adhesion between the tile-holding portion of the tile-supporting tool and the tiles is extremely high, and a airtightness as well as water tightness can also be secured.

Furthermore, there is no anxiety at all about the dirt due to the "efflorescence phenomena" that generate the tile settings due to the backing of mortar and concrete, and there is no anxiety at all about the stripping of the tiles later on.

Claims

1. A tile-supporting tool characterised by:
 - a-base (1a) and a pair of arm members (1b) extending from the base and together defining an elongate channel member; and
 - tile-holding formations (1b) formed in the arm members for engaging corresponding formations in tiles; wherein the base and arm members have a resilient character whereby tiles can be removeably supported between adjacent tile-supporting tools.
2. A tile-supporting tool (1) according to Claim 1, wherein the tile-holding formations (1b) are formed of a pair of generally "V" or "U" shaped pro-

trusions each extending along the length of a respective one of the arm members.

3. A tile-supporting tool according to Claim 2, wherein the protrusions of the arm members are directed away from one another so that they are suitable for being received in corresponding recesses formed in tiles. 5

4. A tile-supporting tool according to Claim 1, 2 or 3, wherein the channel has a generally rectangular cross-section, the arm members extending generally perpendicularly outwardly from one side thereof. 10
15

5. A tile-supporting tool characterised by an elongate base (2a) having a generally "L" shaped cross-section and an arm member (2b) extending along the length thereof, the arm member being provided with a tile-holding protrusion along its length. 20

6. A tile-supporting tool according to Claim 5, wherein the tile-holding portion is of generally "V" or "U" profile and the arm member is of generally "L" shaped cross-section. 25

7. A tiled wall structure comprising tile-supporting tools according to Claim 1 and Claim 2, wherein the tile-supporting tools are fixed at intervals corresponding to the dimensions of the tiles to be supported thereby, wherein the tiles are supported between adjacent tile-supporting tools by the protrusions of the respective tools being resiliently received within corresponding recesses provided in the tiles. 30
35

8. A tile wall structure according to Claim 7 wherein the tile-supporting tools are mounted onto the surface of a steel frame formed in a rectangular lattice frame shape which itself is mounted directly onto a wall surface which may be of concrete. 40

9. A tiled wall structure according to Claim 8 wherein the steel frame has a water proof plate composed of a thin metallic plate on the side thereof away from the wall performing a tiled curtain wall. 45

10. A tiled wall structure according to any one of Claims 7 to 9, wherein a joint member is interposed between the arm members of each tile-supporting tool, the joint member having a generally rectangular or generally circular cross-sectional profile. 50
55

FIG. 1

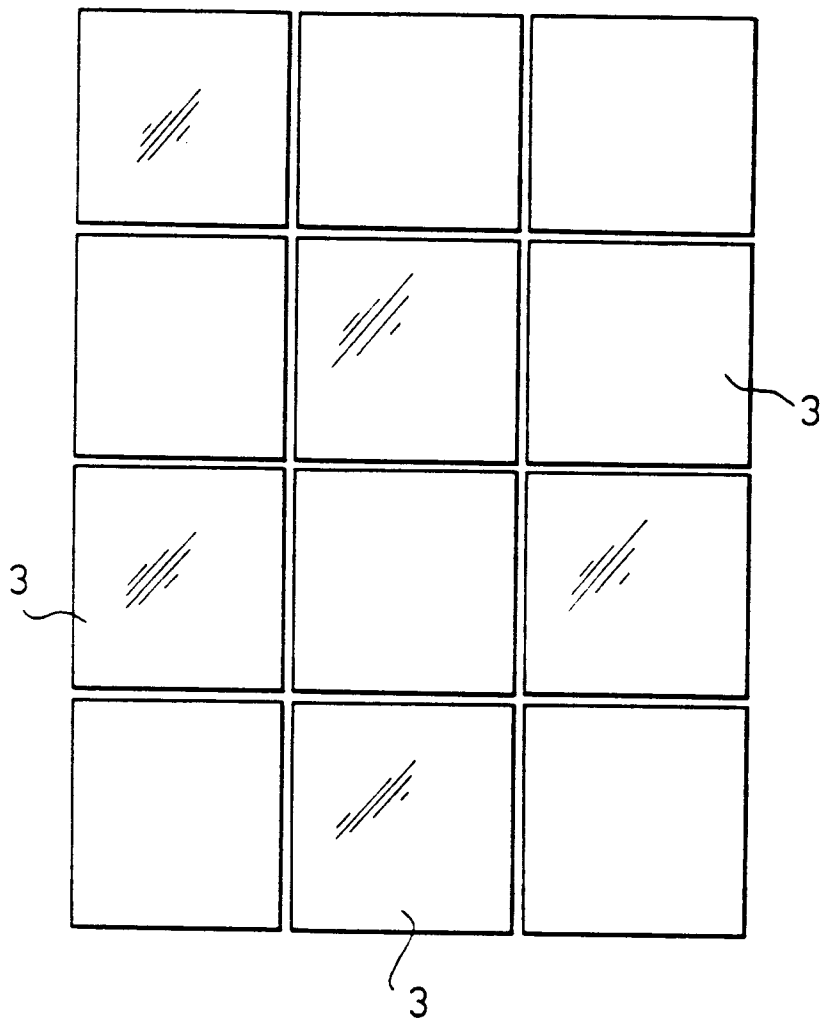

FIG. 2

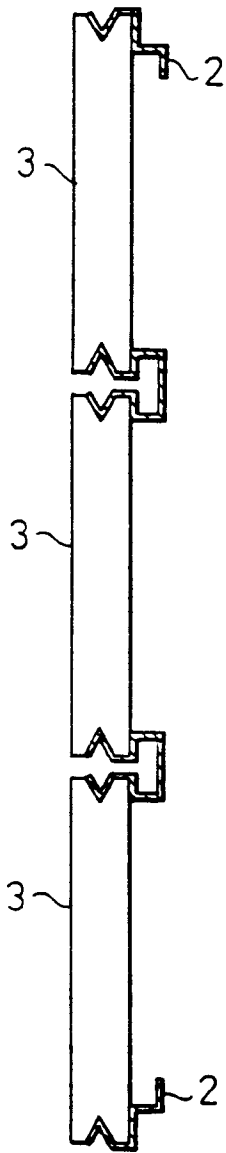

FIG. 3

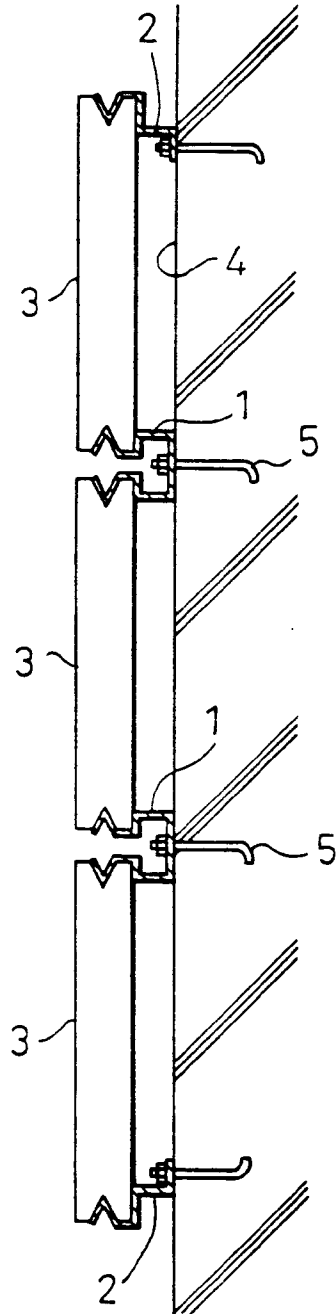

FIG. 4

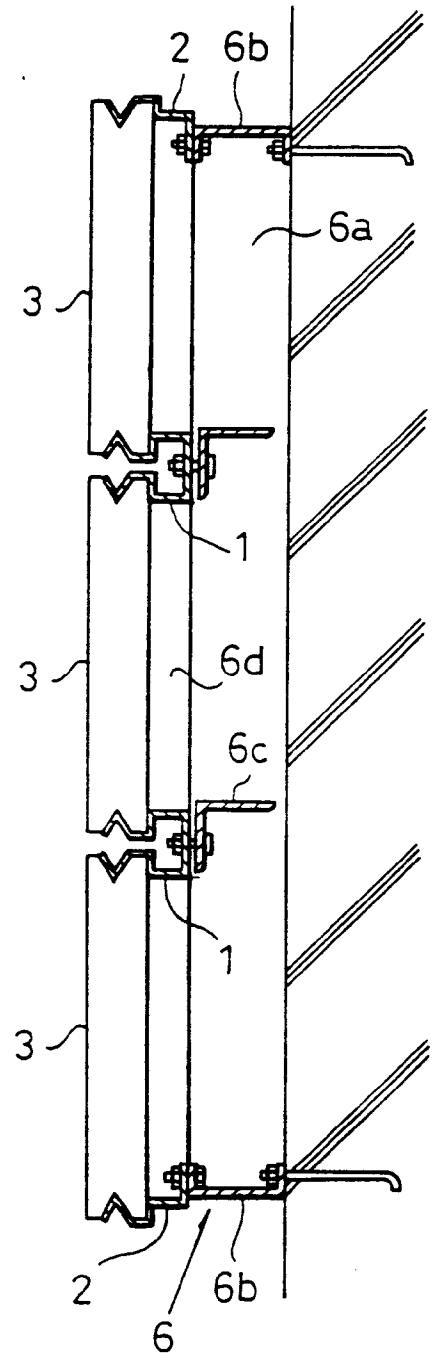

FIG. 5

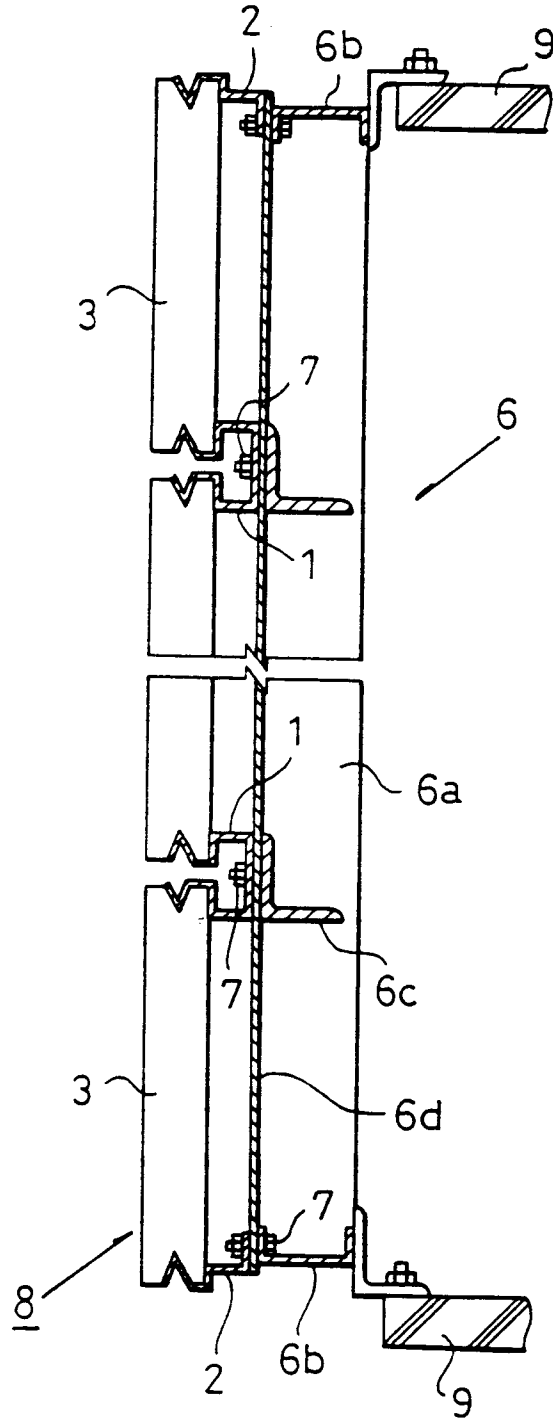

FIG. 6

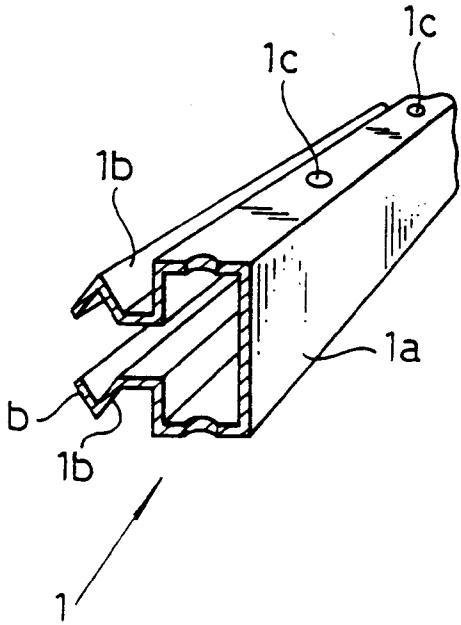

FIG. 7

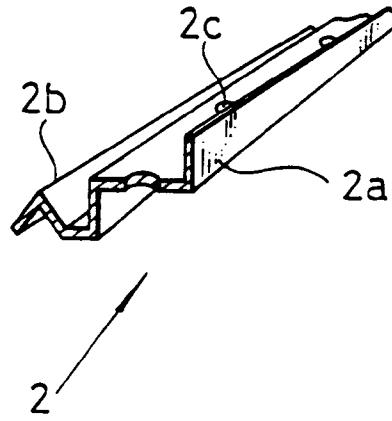

FIG. 8

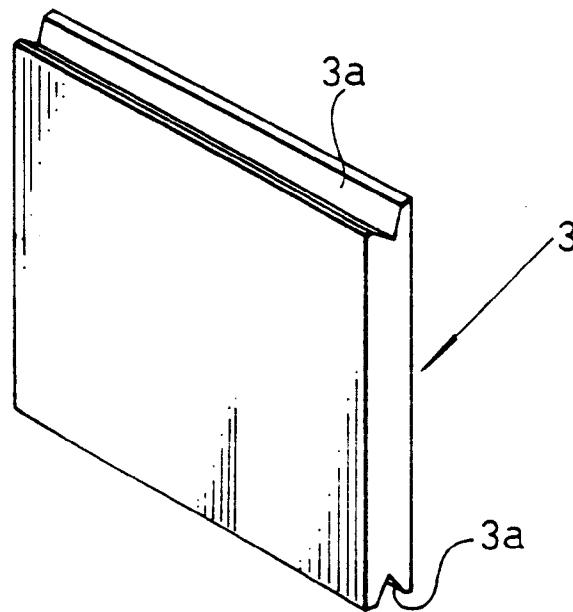

FIG. 9

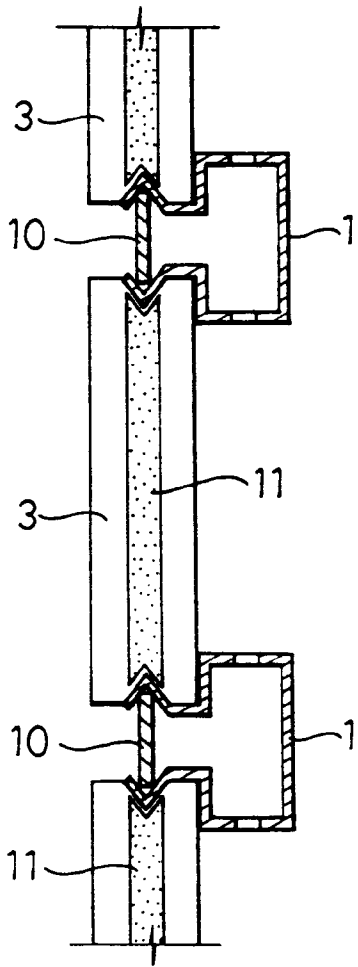

FIG. 10

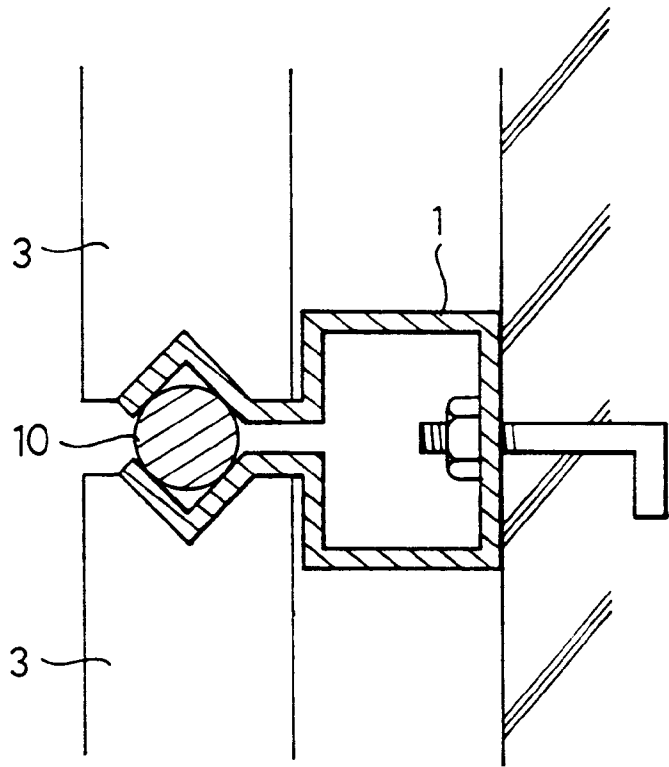

FIG. 11

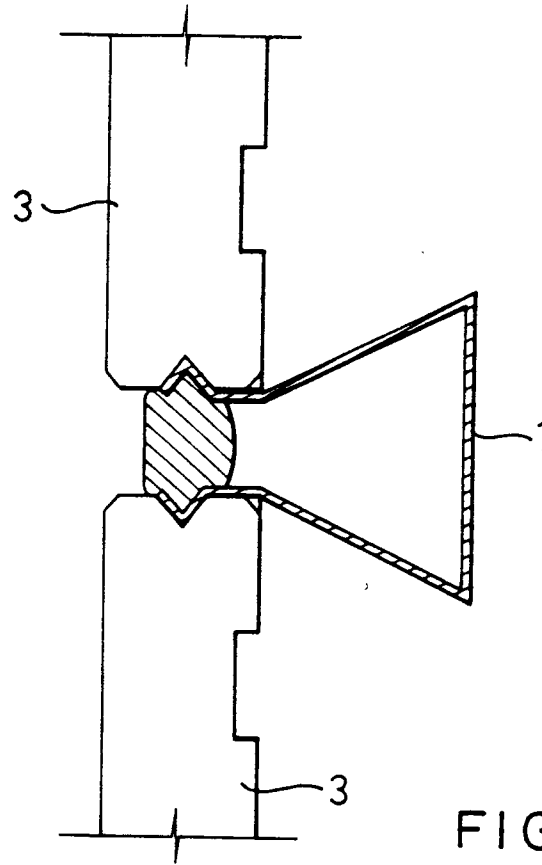

FIG. 12

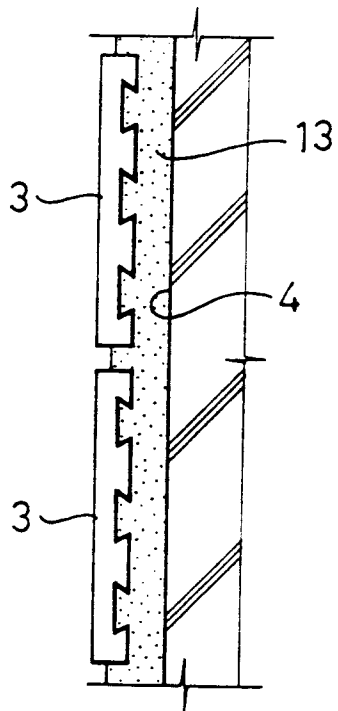
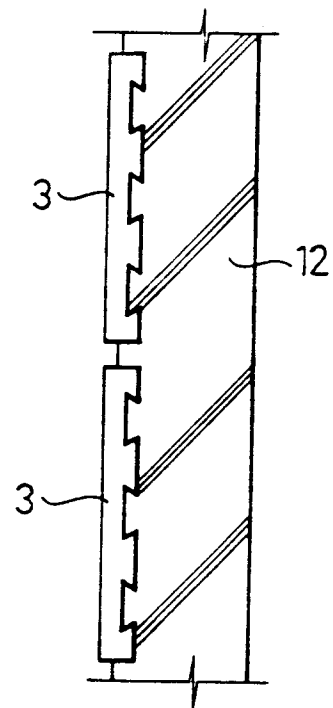

FIG. 13





European Patent Office

EUROPEAN SEARCH REPORT

Application Number

EP 91 30 7220

DOCUMENTS CONSIDERED TO BE RELEVANT			
Category	Citation of document with indication, where appropriate, of relevant passages	Relevant to claim	CLASSIFICATION OF THE APPLICATION (Int. Cl.5)
Y A	US-A-2 054 573 (MENDENHALL) * page 1, right column, line 32 - page 2, right column, line 49; figures 1-6 * ---	1-7 9,10	E04F13/08 E04B2/88
Y A	US-A-3 005 293 (HUNTER) * column 1, line 8 - line 11 * * column 2, line 1 - column 4, line 11; figures 1-15 * ---	1-4,7 8	
Y	FR-A-2 309 681 (KLEIN) * page 4, line 24 - line 38; figures 1,8 * ---	5,6	
A	FR-A-1 104 493 (GAUDINET) * page 2, left column, line 18 - right column, line 36; figures 1-7 * -----	1-4,7	
			TECHNICAL FIELDS SEARCHED (Int. Cl.5)
			E04F E04B
The present search report has been drawn up for all claims			
Place of search THE HAGUE		Date of completion of the search 12 NOVEMBER 1991	Examiner AYITER J.
CATEGORY OF CITED DOCUMENTS		I : theory or principle underlying the invention E : earlier patent document, but published on, or after the filing date D : document cited in the application L : document cited for other reasons & : member of the same patent family, corresponding document	
X : particularly relevant if taken alone Y : particularly relevant if combined with another document of the same category A : technological background O : non-written disclosure P : intermediate document			

EPO FORM 1503 03.82 (PM001)