

(19) **DANMARK**

(10) **DK 2012 00549 A1**



(12) **PATENTANSØGNING**

Patent- og
Varemærkestyrelsen

(51) Int.Cl.: **A 47 B 23/04 (2006.01)**

(21) Ansøgningsnummer: **PA 2012 00549**

(22) Indleveringsdato: **2012-09-04**

(24) Løbedag: **2012-09-04**

(41) Alm. tilgængelig: **2014-03-05**

(71) Ansøger: **Jørgen Holberg Fenger, Avnøvej 30, Svinø, 4750 Lundby, Danmark**

(72) Opfinder: **Jørgen Holberg Fenger, Avnøvej 30, Svinø, 4750 Lundby, Danmark**

(54) Benævnelse: **Kombineret støtte-, fremvisnings- og læseanordning**

(56) Fremdragne publikationer:

DE 1932336 A1

WO 0203836 A1

CH 356888 A

(57) Sammendrag:

The invention relates to a device for combined support, display, exhibition, reading and writing of flat objects, which consist of two separate essentially flat and plane sheet members (10, 20), one of which (10) is made up of an elongated horizontal base part which on its upper surface in the longitudinal direction has a coherent array of transverse serrated steps (13) and at least one transverse slit-formed recess (11), whereas the other member (20) is made up of an elongated mainly vertical erected support part having a sheet thickness which fits into the width of the transverse slit-formed recess (11) in the base part (10) when assembling the two parts, wherein the transverse slit-formed recess (11) is provided at the top of a transverse projecting elevation (12) on the upper surface at one end of the horizontal base part (10) thus forming a selected definite angle between the facing surfaces of the base part (10) and the vertical part (20) when the parts are assembled. Both ends (21, 22) of the vertical support part (20) can be used for introduction into the slit formed recess (11) in the base part (10) to form different selected angles between the surfaces of the plate members (10, 20) facing each other.

Fortsættes ...

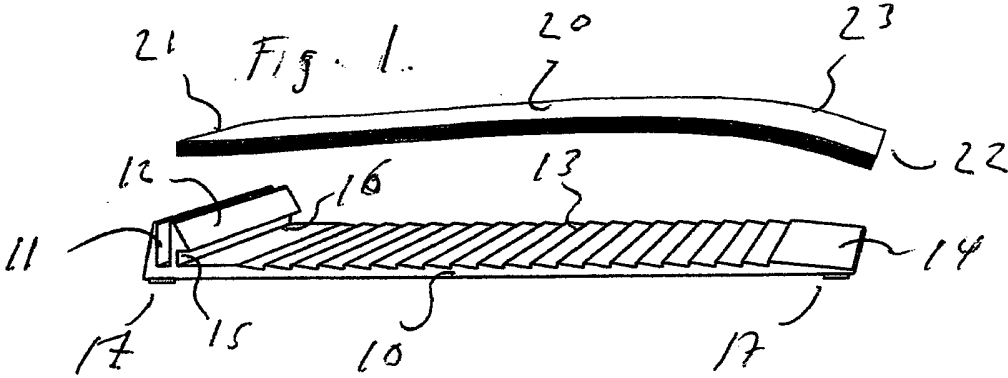

Device for combined support, display, exhibition, reading and writing of flat objects.

The present invention relates to a combined support, display, exhibition, reading and writing device which is constructed so as to be able to be used as classical support
5 for books and other thin objects having an essentially greater extend in each length and width dimensions than in its thickness dimension such as e.g. CD, DVD and blue ray cassettes and other flat thin objects and simultaneous being capable of being used as presentation and exhibition support for such objects in shops, stores, fairs, offices and homes and further more also being capable of being used as support
10 for general books, e-books, tablet PCs, I-pads, mobile telephones, etc. When reading and optionally also writing, if possible, on these media. – The combined bookend, presentation, exhibition, reading and writing device is preferably a self-supporting device which means that the device is capable of performing its function without assistance of other arrangements or constructions apart from the base on
15 which it is placed.

Background of the invention

Classic bookends have been known for many years and are found in numerous versions and constructions. The object with these bookends have always been to produce an organized arrangement of books or similar relative flat thin objects and
20 maintaining them fixed in the selected order in upright position in a bookcase, a bookshelf or on a table in the home, institutions, libraries and offices and others.

The classic bookends are generally objects having two extended plane and flat surfaces which are fixed connected forming a fixed angle with each other of generally
25 about 90°. In use the one surface of the bookend is maintained horizontally against the surface (table surface or bookshelf) on which it is placed by the weight of the objects (books etc.) which are placed on this surface of the bookend by means of which the other surface of the bookend is maintained in a mainly perpendicular vertical position thereby forming a vertical support for the vertically arranged flat objects
30 prohibiting the latter in tipping over.

In its classic version the book end is formed of two flat and plain members of wood, metal or plastic which at their one end edge are fixed connected with each other and thus forms a fixed angle between the surfaces of the plate members. The joining can be produced by mortising, gluing, soldering or welding or combinations thereof depending on the type and nature of the materials. However, there is also numerous examples of book ends in which the angle between the two surfaces is produced by bending of a single sheet formed specimen about a straight line irrespective whether the sheet material consists of wood, metal, plastic or other material which under certain specific physical conditions are ductile.

10

Prior art references

Such classic book ends are described and shown in e.g. US design patent USD 540,859 S, JP 2005334576, DE 20 2004 019 565, CN 201308279, DE 20 2006 015 802, US 1,557,419, GB 583,543, GB 433,757, US 1,992,487, US 1,992,487 and US 2,872,046 the latter of which, however, is somewhat more complicated in design and construction.

15

These book ends suffer, however, of the drawback that they during transportation, shipping and when not in use cannot be collapsed or separated and thus be less voluminous than when used as the two plate members are fixed joined with each other and thus always form a spatial voluminous angle.

20

However, there are also examples of classic book ends which are produced by casting or pressing or other shaping process of the selected raw material, but these book ends do also suffer of the same drawback mentioned above.

25

However, the prior also comprises book ends which do consist of two mainly flat and plane sheet members which in use form a fixed angle with each other, but which before and after use can be collapsed because they are joined with each other by a hinge member as e.g. disclosed in US 2,720,985. – Or they can consist of two plane rectangular oblong sheet members as disclosed in DK patent no. 175,737 which at the one end is provided with one or more bended and perpendicular outwards extending spigots and a recess and/or slits or slots cut out into the interior of the other

30

plate member at a distance from the ends of this member. These book ends have the advantage that they during transportation and shipping or when not in use can be collapsed or separated and thus be placed in packaging which in space are much less voluminous than the book ends in which the two plate members are fixed together and thus always exist in a voluminous angle form.

Of course, the book ends may be provided with ornaments and pictures and other decoration, but generally they cannot be used for displaying, presentation, exhibition and reading of the objects which they support in a more or less upright position.

10

Devices which are intended for such aims are, however, invented and are disclosed in the prior art technical literature, e.g. in CA 2,425,461, US 5,405,019, US 2010/0294908, GB 2,340,390 and DE 10 208 018 794 A1, the latter three applications even disclose display and reading supports which before or after use can be collapsed to flat specimens. However, on the other hand no one of these display and presentation devices are suitable as classic support for an indefinite number of thin plane objects which are desired to be maintained in an upright and organized position. Besides, a part of these well-known display and presentation devices has a relatively complicated construction which make them expensive to produce and exposed to damage during use. Furthermore, their appearance looks rather technical and is definitely without esthetical appeal.

20

Contrary to the above mentioned prior art support and display devices the present invention concerns a device which is suitable for use as both classic book end and as display, presentation, exhibition, reading and writing device for flat objects simultaneous with that it is extremely simple in its construction and has a pleasant esthetical appearance.

25

Summary of the invention

Thus, the present invention relates to a device for combined support, display, exhibition, reading and writing of flat objects, which consist of two separate essentially flat and plane sheet members, one of which is made up of an elongated horizontal base part which on its upper surface in the longitudinal direction is provided with a coher-

30

ent array of transverse serrated steps and at least one transverse slit-formed recess, whereas the other member is made up of an elongated mainly vertical erected support part having a sheet thickness which fits into the width of the transverse slit-formed recess in the base part when assembling the two parts, wherein said trans-
5 verse slit-formed recess extends essentially vertical from the top of a transverse projecting elevation provided on the upper surface at one end of the horizontal base part so that a selected definite angle between the facing surfaces of the base part and the vertical part is formed when the parts are assembled.

10 By providing the slit-formed recess at the top of a projecting elevation on the upper surface of the base part at the one end of that part the remaining portion of the base part can have a very small thickness and still provide sufficient support for the vertical support member.

15 Preferably the transverse serrated steps on the upper surface of the base part are projections having a substantial vertical front face directed towards the position of the transverse projecting elevation on the base part and a backwards sloping rear surface. Preferably the total area of the upper surface of the base part or the major part thereof is provided with a coherent array of such serrated step projections ex-
20 cept for a small length corresponding to about the extent of two to three steps nearest the front face of the elevation at the end of the base part.

That part of the vertical plate member which projects down into the slit-formed recess is preferably faintly curved in the longitudinal or cross direction, preferably in
25 the cross direction so that this part is firmly squeezed in the slit-formed recess even though the width of the slit formed recess is slightly greater than the thickness of the vertical plate member. Both ends of the vertical member may be faintly curved in the cross direction. Alternatively the slit formed recess in the base part may be weakly wedge-shaped in cross section so that it is broadest at top and narrowest at bottom
30 or vice versa. – This are advantages embodiments because it may be extremely difficult to produce both the with of the slit and the thickness of the vertical sheet member with sufficiently narrow or confined margins to always providing a tight-

fitting there between when assembling the plate members without having to use expensive manufacturing and machining processes.

5 Preferably one end of the vertical plate member is substantially straight in the longitudinal direction whereas the other end is provided with a distinct stronger curvature or bending in the longitudinal direction. This feature makes it possible to obtain different angles between the facing surfaces of the base part and the vertical part that are either equal to or greater or smaller than 90° depending on whether the straight part end or the distinct curved or bended end of the vertical plate member is
10 mounted downwards and stuck into the vertical slit-formed recess in the elevation of the base part and whether the distinct curved end bends away from or towards the serrated surface of the base part. This feature makes its possible to obtain different abutment faces or points for the objects which are placed on the base part and leans against the vertical plate member or the upper end of it. At the same time the distinct
15 curvature or bending may per se cause a tight squeezing in the slit-formed recess when the curvature or bending starts sufficiently near the end of the vertical plate even when the thickness of the vertical plate member is slightly smaller than the width of the slit formed recess.

20 Both ends of the vertical part may be provide with a thin cap or cover of e.g. rubber, silicone, silicone-rubber or plastic in order to protect it against scratching and wear and tear when it is assembled and separated several times during use.

The transverse projecting elevation on the upper surface of the horizontal base part
25 may preferably also be provided with a transverse horizontal side slit recess in the front face and at the bottom of the elevation having a width which fits tight to sheet thickness of the vertical support part. This feature makes it possible to have the device firmly assembled in collapsed state when the straight end of the vertical part is stuck into this side slit recess making the device well suited for storing or transportation as its volume then is diminutive. – If the distinct curved end of the vertical part is
30 stuck into the side slit of the transverse elevation on the upper surface of the horizontal base part the parts are joined together so that the curvature is bending away from the base part a very acute angle is formed between the base part and the verti-

cal part. This configuration the makes it very suitable as support for an iPad or a tablet PC when it is desired to have it in a comfortable writing position because the iPad or tablet PC will be supported in a slightly inclined angle ideal for writing on it.

5 Both the base part and the vertical part of the device can be made of the same material, e.g. metal, plastic or wood, but preferably the two parts are produced of different materials so that the base part is made of the heaviest material, e.g. stainless steel, aluminum, and aluminum alloy or other metal alloy, whereas the vertical part is made of a lighter material such as plastic, e.g., in particular ABS-plastic, but also
10 other materials may be selected. – When the base part is produced of a heavier material than the vertical part the assembled device itself will be stable and not tend to tip over even when no supported objects are placed on the base part of the device.

In a preferred embodiment the base part is made of extruded aluminum which preferably has an anodized surface which optionally may be coloured. The sheet thickness of such aluminum base member will generally be between 1 - 5 mm, preferably
15 1 - 3 mm, e.g. 2 mm.

At one of its ends such aluminum base part is preferably provided with an elevated projection having a transverse slit formed recess therein. The dimensions of the
20 base part may of course vary considerably depending on the objects to which it is intended to be used for. When used as support for CD, DVD and blue ray cassettes the length x, width x height of projection may e.g. be 160 x 55 x 12 mm provided with a slit width of 2.5 - 3 mm and a slit depth in the projection of about 7 - 10 mm.

25 In such preferred aluminum part the corresponding verticals support plate member is preferably made of ABS-plastic having a length x width x thickness dimensions of 150 x 55 x 2.5 - 3 mm. The ABS-plastic may be clear and transparent, but it may also be coloured by any desired shade according to the intended use of the support
30 device and the fashionable cover at the time of marketing. This makes it also possible for a consumer of the device to replace the vertical part of the support device without also having to replace the base part.

The use of extruded aluminum and ABS-plastic for the parts of the support device has the further advantage that the materials are both relatively cheap, easy to produce and manufacture into the desired shape and additionally both are recyclable materials and do not contribute to waste of material or pollution when the support device for one or another reason at some time is discarded.

Description of the drawings

The present invention will now be further described more detailed with reference to the figures of the drawing, wherein:

10 Fig. 1 is a perspective view of the individual parts of an embodiment of the support device according to the invention in separate condition,

Fig. 2 is a perspective view of the individual parts of the embodiment shown in Fig. 1 in collapsed and assembled state,

15 Fig. 3A and B are perspective views of the embodiment of the support device shown in Fig. 1, wherein the parts are joined together so that a right angle is formed between the base part and the vertical part by sticking the straight end of the vertical part into the vertical slit of the transverse elevation on the upper surface of the horizontal base part. In Fig. 3A the distinct curved part is pointing forward whereas in Fig. 3B it is pointing backwards.

20 Fig. 4 is a perspective view of the embodiment of the support device shown in Fig. 1, wherein the parts are joined together so that a very acute angle is formed between the base part and the vertical part by sticking the distinct curved end of the vertical part into the side slit of the transverse elevation on the upper surface of the horizontal base part,

25 Fig. 5A is a perspective view of the embodiment of the support device shown in Fig. 1, wherein the base part and the vertical part are joined together so that an acute angle is formed between said parts,

30 Fig. 5B is a perspective view of the embodiment of the support device shown in Fig. 1, wherein the parts are joined together so that an obtuse angle is formed between the base part and the vertical part,

Fig. 6A, B, C, D, E, and F are cross sectional views of the six possible configurations obtainable by assembling the two parts of the support device shown in Fig. 1 in different manner,

5 Fig. 6 is an exploded perspective view of three of the four possibilities for assembling the base part and the vertical part of the embodiment of the invention shown in Fig. 2,

Fig. 7 is a cross section of the support device configuration shown in Fig. 3A when two such support devices are used as classic bookend for a great number of vertically placed flat objects such as CD, DVD and blue ray cassettes,

10 Fig. 8 is a cross section of the support device configuration shown in Fig. 3A when one such support device is used as classic bookend for a great number of vertically placed flat objects such as CD, DVD and blue ray cassettes,

Fig. 9 is a cross sectional view of the configuration shown in Fig. 5B when used as display or exhibition support for a number of flat upright backwards inclined objects,
15 wherein the base part and the vertical part forms an obtuse angle between them,

Fig. 10 is a cross section of the configuration embodiment shown in Fig. 3B when used as support for one single flat backwards inclined flat object, wherein the base part and the vertical part forms a right angle between them,

Fig. 11A, B, and C are a cross sectional views of the configuration embodiment
20 shown in Fig. 5A when used as display or reading support for a single flat object of relatively minor dimensions, such as a tablet PC, an e-book or an iPad, wherein the base part and the vertical support parts forms an acute angle between them, the only difference be that the flat object is disposed at different angles to the base part.

Fig. 12 is a cross sectional view of the configuration embodiment shown in Fig. 5A
25 when used as display or reading support for a flat object having of relatively major dimensions, such as a general book, wherein the base part and the vertical support part forms an acute angle between them,

Fig. 13 is a cross sectional view of the configuration embodiment shown in Fig. 4
30 when used as writing support for a single flat object of relatively minor dimensions, such as a tablet PC, an e-book or an iPad, wherein the base part and the vertical

support parts forms a very acute angle between them, providing a gentle slope comfortable the hand position when writing,

Fig. 14 shows the same as Fig. 1, but enlarged and in greater details, and

Fig. 15 shows the end part of the base part shown in Fig. 14 comprising the projected elevation with its two slit-formed recesses and its front plateau.

Detailed description of the invention

As mentioned in the list of figures, Fig. 1 is a perspective view of the individual parts of an embodiment of the support device according to the present invention in separate condition. A horizontal base part, 10 has an upper surface which is provided with a coherent array of transverse serrated steps 13 which are able to provide resistance against backwards directed horizontal sliding of the lower ends of flat objects which are placed in an inclined position on the base member 10. The base member 10 has an elongated rectangular form the one end 14 of which is gently tapered in cross section so that the upper surface of the base part at its very end is substantially at level with the surface of the construction, e.g. a table or other furniture, on which the base member is placed. At the other end the base member 10 is provided with an erected projection or elevation 12 wherein an essential vertical transverse slit 11 is formed for receiving an end 21, 22 of the vertical support member 20 of the support device. This end 21, 22 fits tightly into the transverse slit-formed recess 11. A tight fitting is obtained either by giving the sheet thickness of the vertical part 20 and the width of the transverse slit 11 exactly the same dimensions or by producing the sheet thickness slightly smaller than the width of the slit and simultaneously imparting the end 21 of the vertical member a faint curvature in the longitudinal or cross direction, preferably in the cross direction. Alternatively the transverse slit-formed recess may be slightly wedge-shaped having a greater width at top than at bottom or vice versa, but such that at the narrowest place the width is slightly smaller than the thickness of the sheet member 20. In the first case the tight fitting is obtained between the sheet member 20 and the slit-formed recess by forcing the sheet member 20 as far as it is possible towards the bottom of the slit. In the second case the tight fitting is obtained by forcing the upper edges of the erected projection slightly from each other when the end 21 of the sheet member is pressed

down into the slit. At its one end 22 the sheet member 20 is provided with a greater curvature or bending 23. This curvature or bending provides possibility for producing different configurations of the support device as will be explained in more detailed below.

5

Fig. 14 shows the same embodiment as Fig. 1, but enlarged and in greater details. It is seen that the erected projection 12 in cross section has outer surfaces which are slightly wedge-shaped at the upward direction, whereas the inner surfaces are the projection, which constitute the inner walls of the slit-formed recess 11, are parallel and extend vertically. Thus, the thickness of material in the individual wall in the slit 10 11 is broadest at bottom and smallest at top which provide a stronger material construction that is less disposed to be broken loose from the base part than if the projection had parallel extending outer and inner surfaces.

15 Fig. 2 is a perspective view of the individual parts of the embodiment shown in Fig. 1 in a collapsed and assembled state, The transverse projecting elevation 12 on the upper surface of the horizontal base part 10 is provided with a transverse horizontal side-slit recess 15 in the front face and at the bottom of the elevation 12 having a width which fits tight to sheet thickness of the vertical support part 20. This feature 20 makes it possible to have the device firmly assembled in collapsed state when the straight end 21 of the vertical part is stuck into this side slit recess 15 making the device well suited for storing or transportation as its volume then is diminutive. – If the distinct curved end 22 of the vertical part 20 is stuck into the side-slit of the transverse elevation 12 on the upper surface of the horizontal base part 10 the parts are 25 joined together so that the curvature is bending away from the base part a very acute angle is formed between the base part and the vertical part. This configuration the makes it very suitable as support for an iPad or a tablet PC when it is desired to have it in a comfortable writing position because the iPad or tablet PC will be supported in slightly inclined angle ideal for writing on it.

30

Fig. 3A and B are perspective views of the embodiment of the support device shown in Fig. 1, but depicted in an assembled state. The numbers have the same mean-

ings as in Fig. 1. In Fig. 3A the distinct curved end 22 points forwards to the right whereas in Fig. 3B the distinct curved end 22 points backwards to the left.

Fig. 4 is a perspective view of the embodiment of the support device shown in Fig. 1, wherein the parts are joined together so that a very acute angle is formed between the base part 10 and the vertical part 20 by sticking the distinct curved end 22 of the vertical part 20 into the horizontal side slit 15 of the elevation 12 positioned in level with the upper surface of the horizontal base part 10. Because the upper surface of the base part is without any serrated steps just before the elevation 12 and is constituted of a plateau 16 it is easy to introduce the curved end 22 into the horizontal slit 15.

Fig. 5A is a perspective view of the embodiment shown in Fig. 1 in assembled condition, but wherein the more curved or bended end 22 of the vertical sheet member 20 is introduced into the slit-formed recess in the projection 12 so that an acute angle is formed between the upper surface of the base part 10 and the surface of the vertical sheet part 20 facing towards it.

Fig. 5B is a perspective view of the embodiment shown in Fig. 1 wherein the more curved or bended end 22 is introduced into the slit-formed recess 11 in the projection 12 on the base part 10, but in this case mounted opposite the manner shown in Fig. 5A so that an obtuse angle is formed between the upper surface of the base part 10 and the surface of the vertical sheet part 20 facing towards it.

Fig. 6A, B, C, D, E, and F are cross sectional views of the six possible configurations obtainable by joining the horizontal base part 10 and the vertical support part 20 shown in Fig. 1 in different manner. It is seen that the possible configurations of the device makes it exceedingly suitable for many particular uses in spite of the fact that it is only made up of only two simple parts.

Fig. 7 is a cross section of the support device configuration shown in Fig. 3A when two such support devices are used as classic bookends for a great number of vertically placed flat objects such as CD, DVD and blue ray cassettes.

Fig. 8 is a cross section of the support device configuration shown in Fig. 3A when one such support device 10, 20 is used as classic bookend for a great number of vertically placed flat objects such as CD, DVD and blue ray cassettes,

5

Fig. 9 is a cross sectional view of the embodiment of the configuration shown in Fig. 5B when used as display or exhibition support for a small number of flat erected backwards inclined objects, wherein the base part and the vertical part form an obtuse angel with each other. It is seen that the transverse serrated step projections 13 on the upper surface of the base part 10 prevent the lower ends of the supported objects from sliding forwards so the objects are locked in the position in which they are placed on the device.

10

Fig. 10 shows in cross section the configuration in Fig. 3B when used as presentation or reading support for one single flat object of relatively minor dimensions, such as an e-book or iPad, wherein the base part and the vertical support part form a right angle between them. Again the serrated transverse step projections 13 function as locking mechanism for the lower end of the supported object and thus lock the inclined position selected for the supported object.

20

Fig. 11A, B, and C are a cross sectional views of the configuration embodiment shown in Fig. 5A when used as display or reading support for a single flat object 35 of relatively minor dimensions, such as a tablet PC, an e-book or an iPad, wherein the base part 10 and the vertical support part 20 form an acute angle between them, the only difference be that the flat object is disposed at different angles to the base part. This is due to the fact that the serrated transverse step projections 13 act as the locking mechanism for the selected inclined position of the supported object.

25

Fig. 12 is a cross sectional view of the configuration embodiment shown in Fig. 5A when used as display or reading support for a flat object 40 having relatively major dimensions, such as a general book, wherein the base part 10 and the vertical support part 20 form an acute angle between them. In spite of its small dimensions the

30

support device of the invention is also capable of maintaining such greater objects in a stable position.

Fig. 13 is a cross sectional view of the configuration embodiment shown in Fig. 4
5 when used as writing support for a single flat object of relatively minor dimensions, such as a tablet PC, an e-book or an iPad, wherein the base part 10 and the vertical support part 20 form a very acute angle between them. This provides a gentle slope very comfortable for the hand position when writing. The iPad is indicated by 35 whereas the writing hand is indicated by 50.

10

Fig. 15 shows the end part of the base part shown in Fig. 1 and 14 comprising the projected elevation 12 with its vertical slit-formed recess 11 and its horizontal side-slit recess 15 formed therein and its plane front plateau 16 formed on the top surface of the base part 10. Also an antiskid pad 17 mounted on the underside of the base
15 part 10 is clearly shown. Usually one such antiskid pad will be mounted at each of the four corners of the base part. Such antiskid parts may be made of rubber, silicone-rubber, plastic or other antiskid materials.

From the above general and detailed description of the support device according to
20 the invention it will be understood that in spite of its simple construction it provides possibility for assembling the support device in a total of six configurations and these six different configurations provides each possibilities for an even greater number of possible applications varying from use as "classic bookend" for flat box formed objects which are desired to be held in place in a desired order to the use as display,
25 presentation and exhibition support for one or more flat box formed objects in shops and stores, libraries and fairs. Furthermore, the support device can also be used as support for both classic paper books as well as modern e-books, tablet PCs, iPads, iPhones and common portable phones which are not themselves provided with any form for support and therefore either must be hold in hand, which for longer periods
30 or time is fatiguing, or otherwise be placed horizontally on a table or other surface, which makes reading and or writing difficult when a person also wants to sit in a comfortable reading or writing position.

Besides, the support device according to the invention is strong and sturdy and simple to assemble as it do not require any form of tools for the joining process.

5 Finally, the device is simple and cheap to package, dispatch and store, because the two parts are very thin and can be collapsed to a thickness that can be included in an ordinary letter envelope.

CLAIMS

1. A device for combined support, display, exhibition, reading and writing of flat objects, which consist of two separate essentially flat and plane sheet members (10, 20), one of which (10) is made up of an elongated horizontal base part which on its upper surface in the longitudinal direction has a coherent array of transverse serrated steps (13) and at least one transverse slit-formed recess (11), whereas the other member (20) is made up of an elongated mainly vertical erected support part having a sheet thickness which fits into the width of the transverse slit-formed recess (11) in the base part (10) when assembling the two parts, **characterized** in that said transverse slit-formed recess (11) extends essentially vertical from the top of a transverse projecting elevation (12) provided on the upper surface at one end of the horizontal base part (10) so that a selected definite angle between the facing surfaces of the base part (10) and the vertical part (20) is formed when the parts are assembled.
2. A device according to claim 1, wherein the transverse serrated steps (13) on the upper surface of the base part (10) are projections having a substantial vertical front face facing towards the position of the transverse projecting elevation (12) on the base part (10) and a backwards sloping rear surface.
3. A device according to claims 1 or 2, wherein the total area of the upper surface of the base part (10) or a major part thereof is covered with a coherent array of transverse serrated steps (13) except for a small length (16) corresponding to about the extent of two to three steps nearest the front face of the elevation (12) at the end of the base part (10).
4. A device according to any of claims 1, 2 or 3, wherein the end part (21, 22) of the vertical plate member (20) which projects down into the slit-formed recess (11) is faintly curved in the longitudinal or cross direction, preferably in the cross direction, so that this end part is firmly squeezed in the slit-formed recess (11) even though the width of the slit formed recess is slightly greater than the thickness of the vertical plate member.

5. A device according to any of the preceding claims, wherein the slit-formed recess (11) in the transverse projecting elevation (12) on the upper surface of the base part (10) may be weakly wedge-shaped in cross section so that it is broadest at top and narrowest at bottom or vice versa.

5

6. A device according to any of the preceding claims, wherein the one end (21) of the vertical member (20) is substantially straight in the longitudinal direction whereas the other end (22) is provided with a distinct stronger curvature or bending (23) in the longitudinal direction of the member (20).

10

7. A device according to claim 6, wherein the distinct curvature or bending (23) starts sufficiently near the end (22) of the vertical part (20) so that it per se may cause a tight squeezing in the slit-formed recess even when the thickness of the vertical plate member (20) is slightly smaller than the width of the slit formed recess (11).

15

8. A device according to any of the preceding claims, wherein the transverse projecting elevation (12) on the upper surface the horizontal base part (10) also is provided with a transverse horizontal side slit recess (15) in the front face and at the bottom of the elevation (12) having a width which fits tight to sheet thickness of the vertical support part.

20

9. A combined device according to any of the preceding claims, wherein the two support members (10, 20) are produced of different materials so that the base part (10) is made of a heavier material, e.g. stainless steel, aluminum, an aluminum alloy or other metal alloy, whereas the erected part (20) is produced of a lighter material such as plastic.

25

10. A combined device according to claim 9, wherein the base part (10) is produced of extruded aluminum which preferably has an anodized surface which optionally may be colored, whereas the matching vertical support part (20) is produced of ABS plastic that may be clear or transparent, but also may be colored with any desired shade.

30

1/6

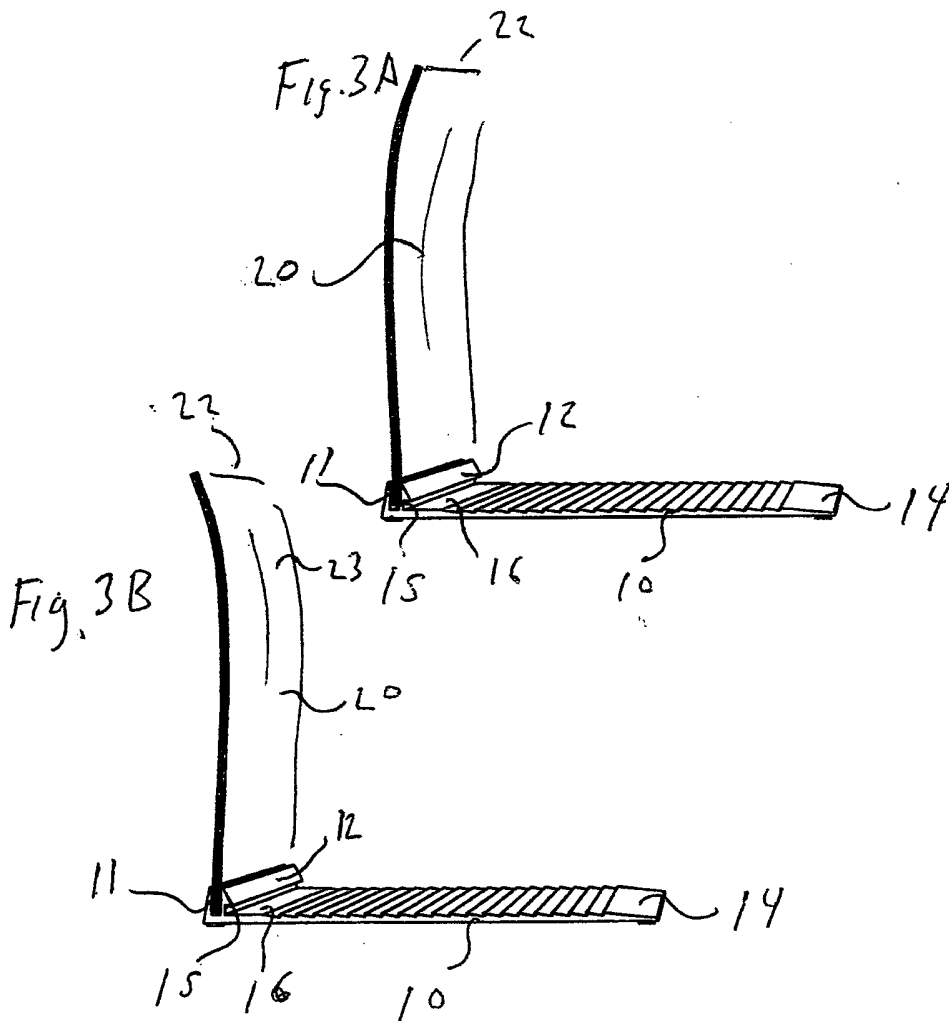
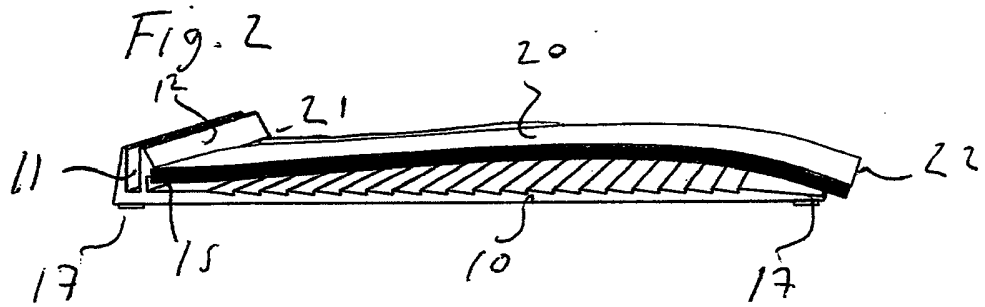
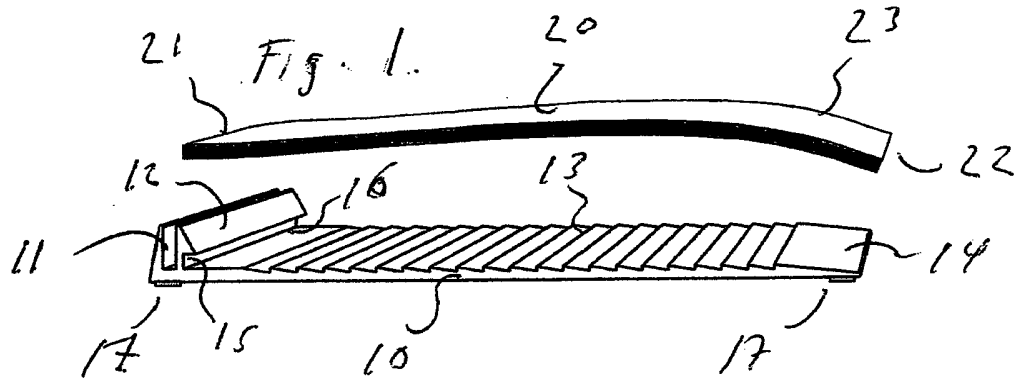
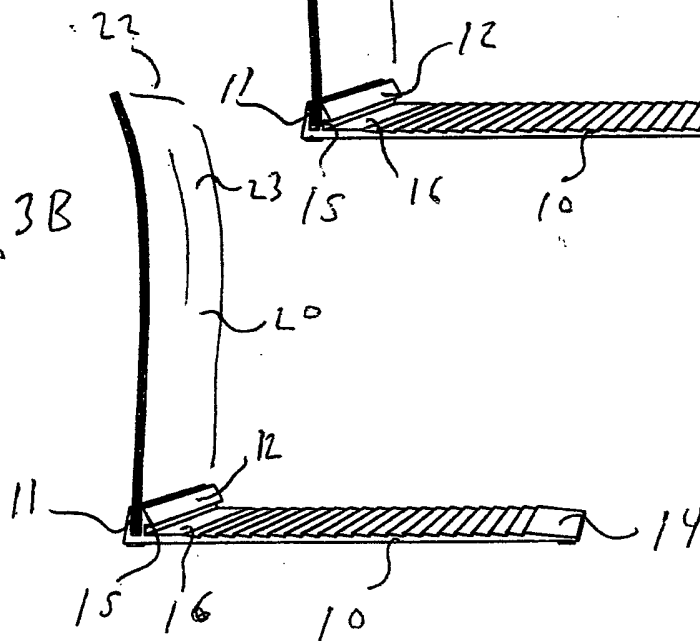
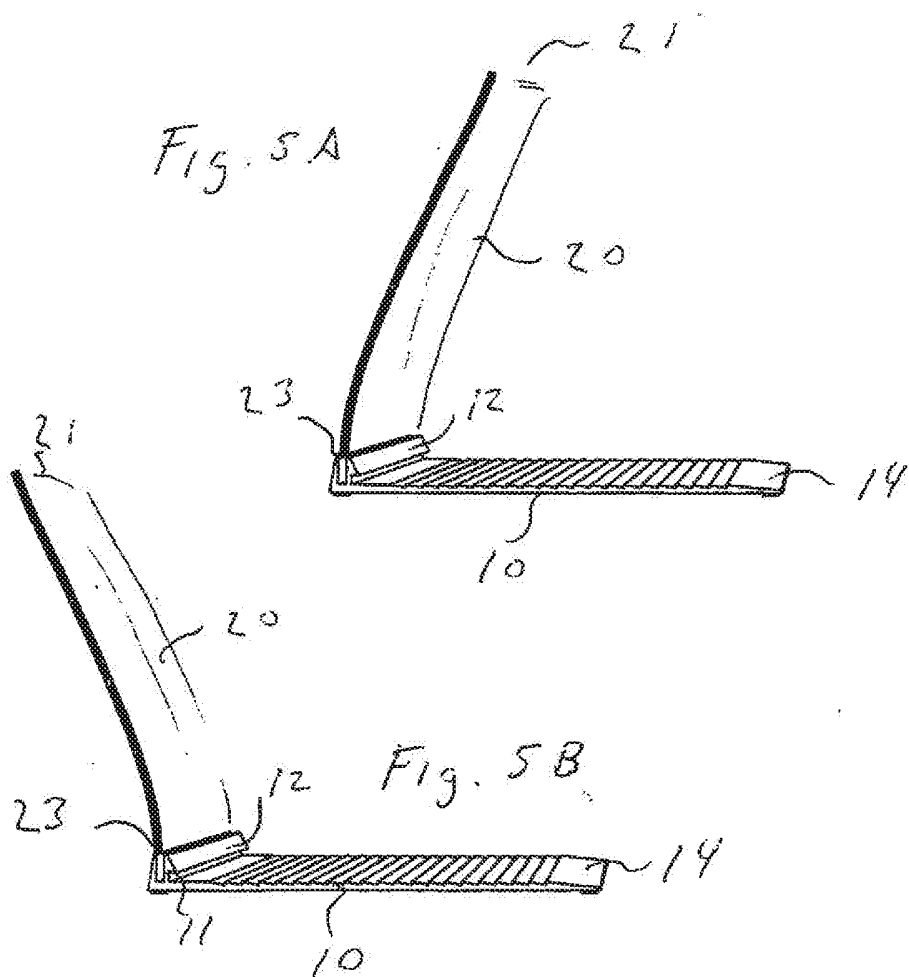
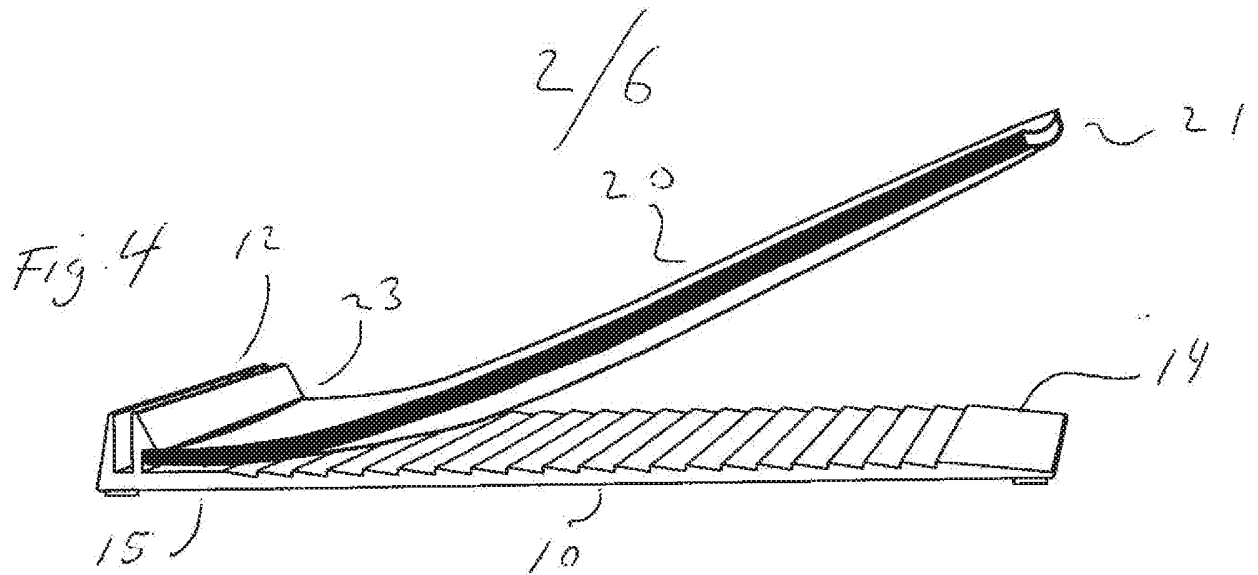

Fig. 3B





3/6

Fig. 6A

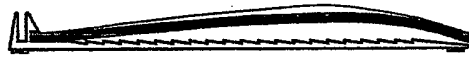

Fig 6B²



Fig. 6B¹

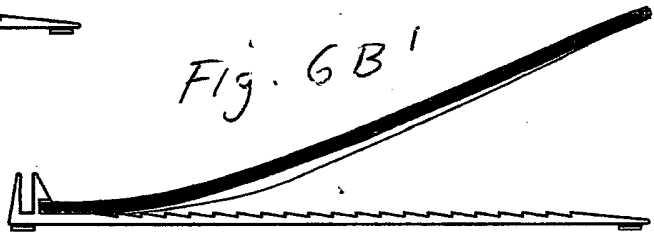

Fig. 6C

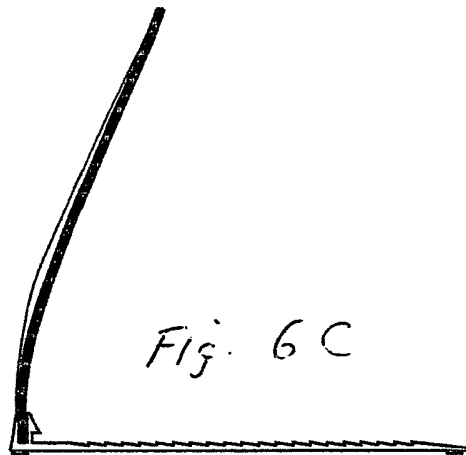

Fig. 6D

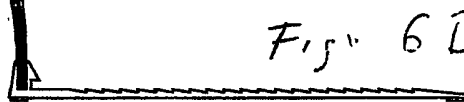
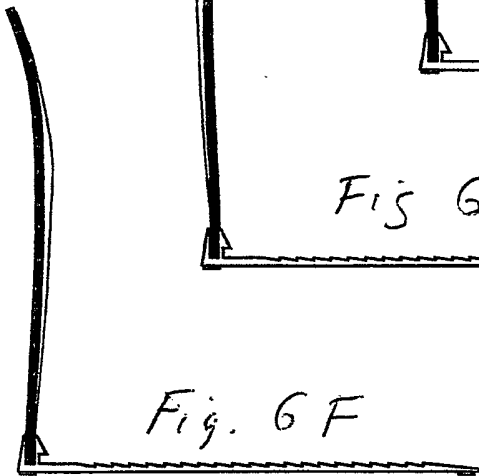

Fig 6E



Fig. 6F



4/6

Fig. 7

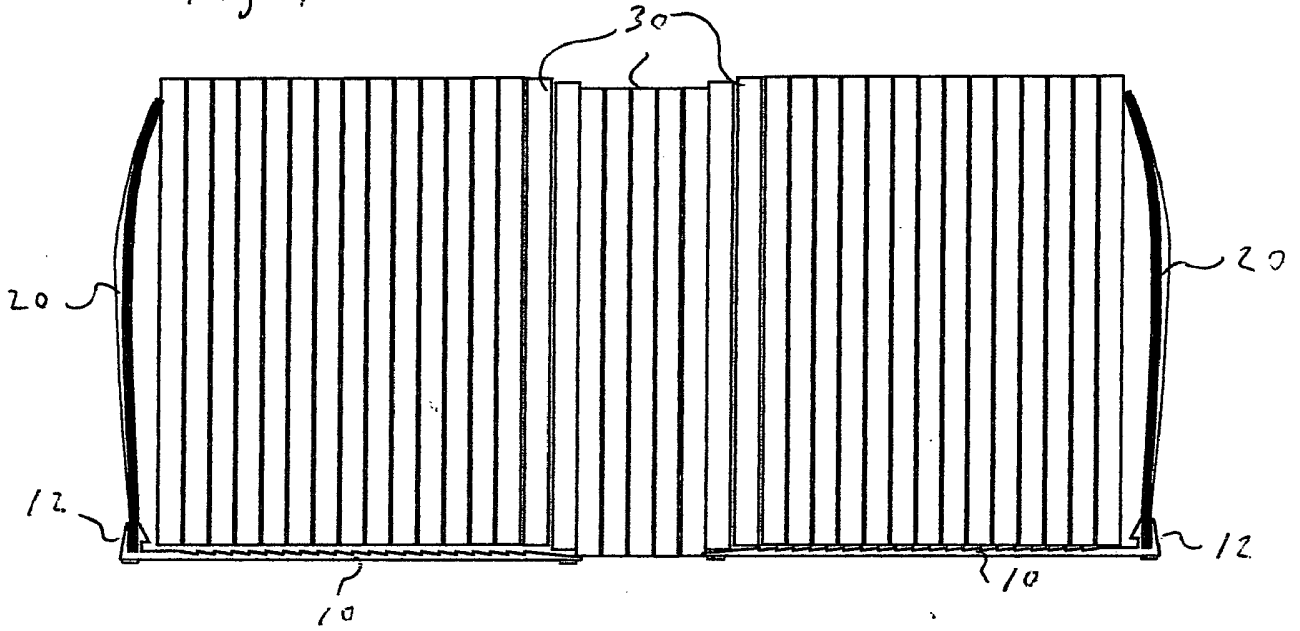

Fig. 8

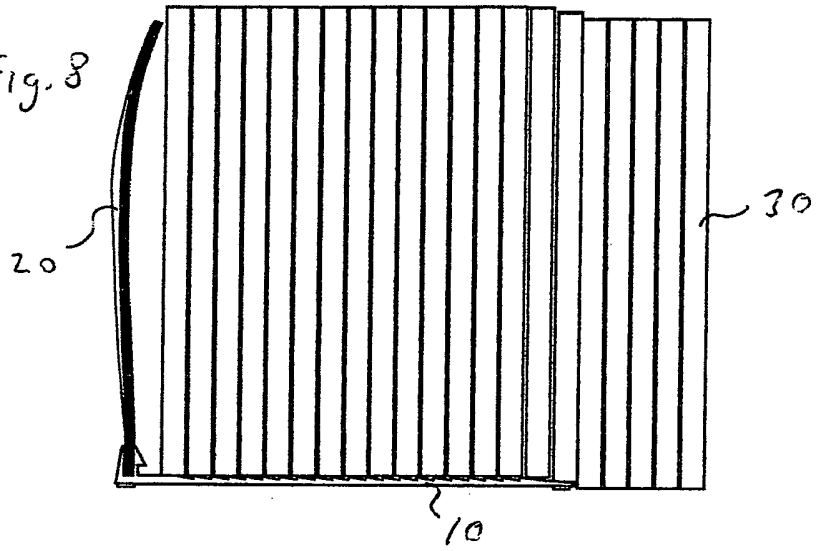

Fig. 9

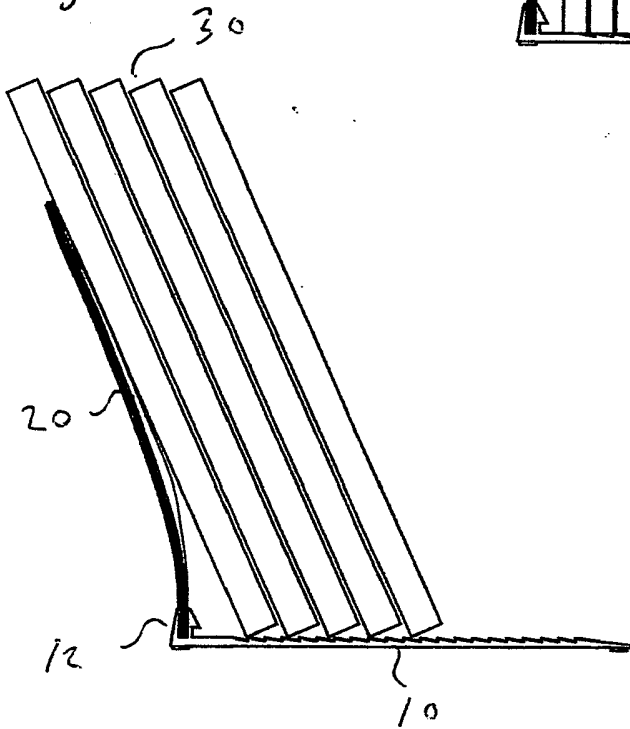

Fig. 10

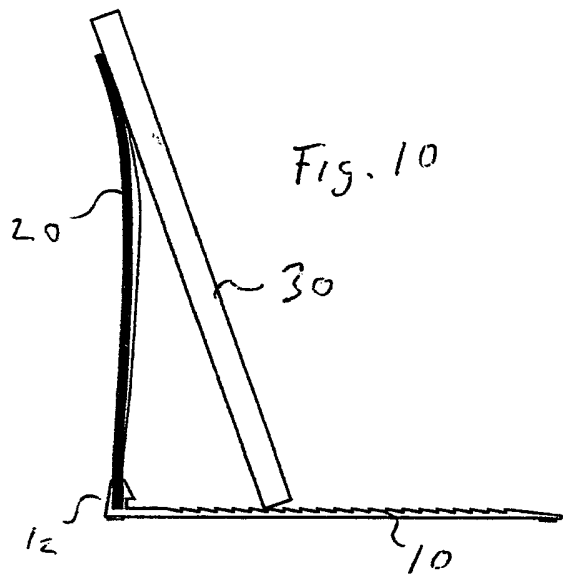

Fig. 11A

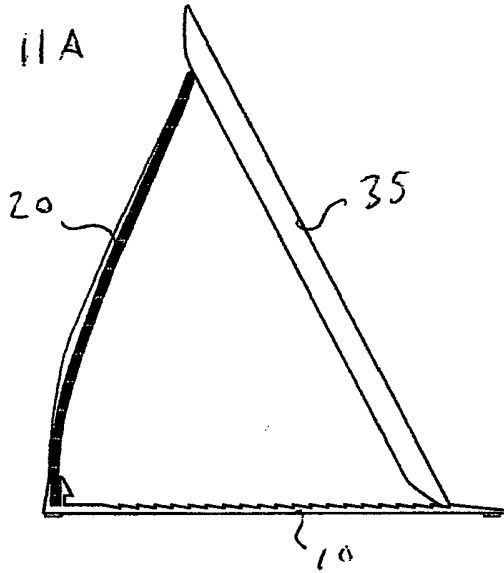

Fig. 11B

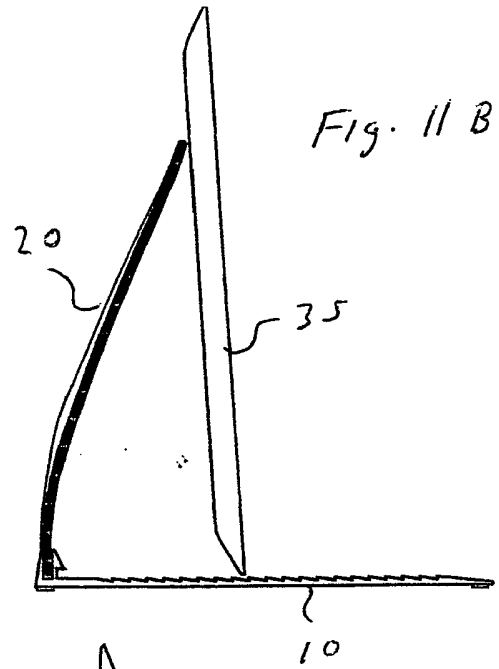

Fig. 12

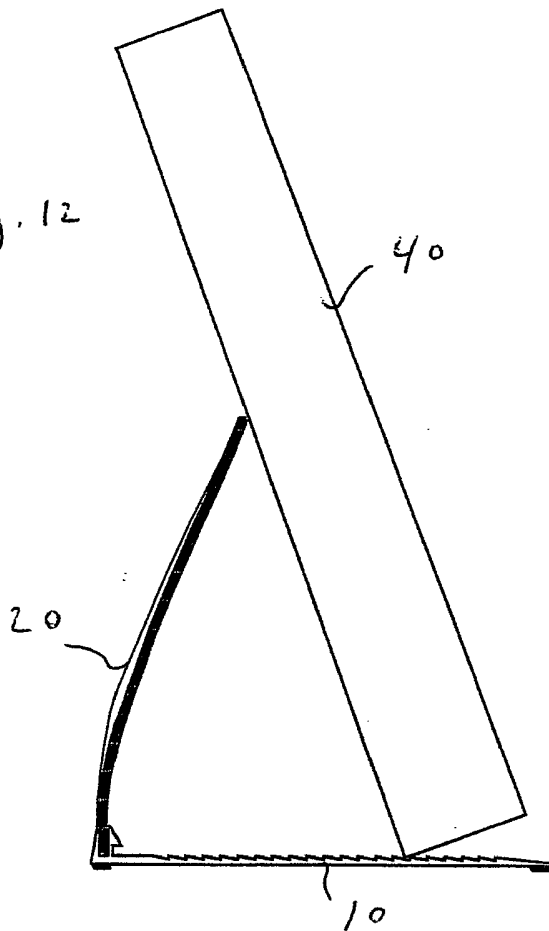

Fig. 11C

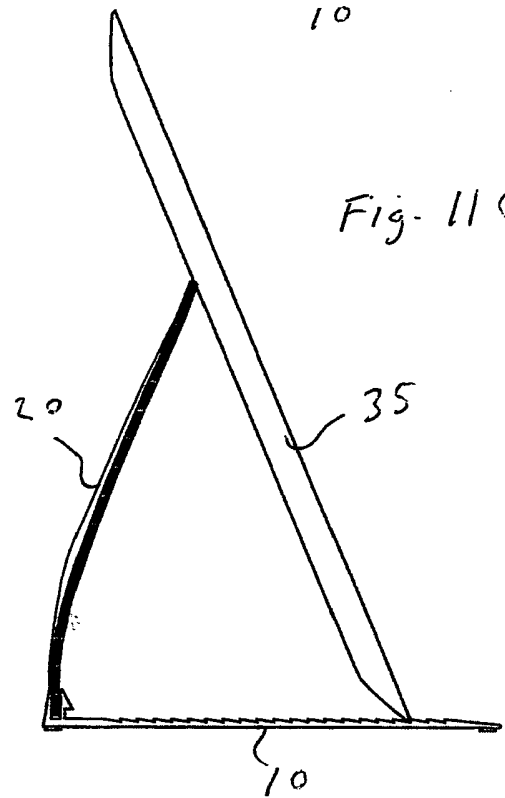

Fig. 13 A

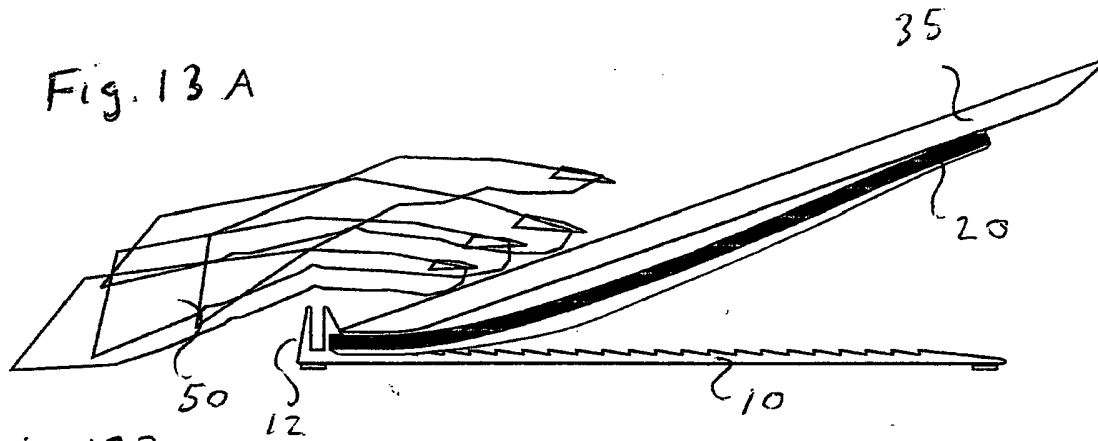

Fig. 13 B

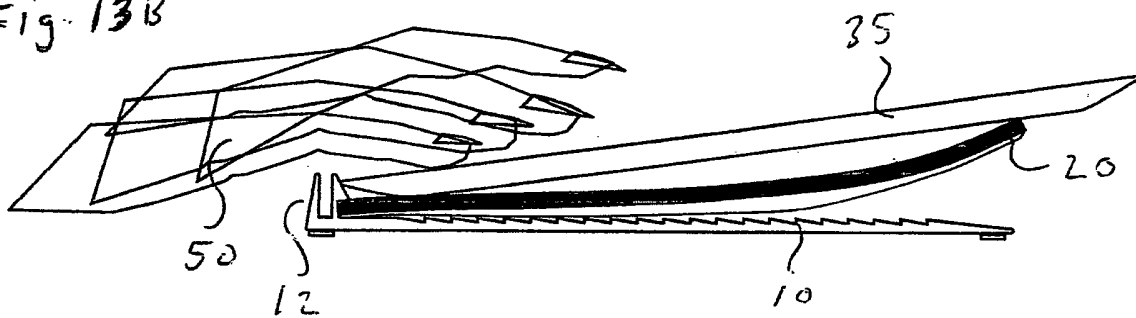

FIG. 14

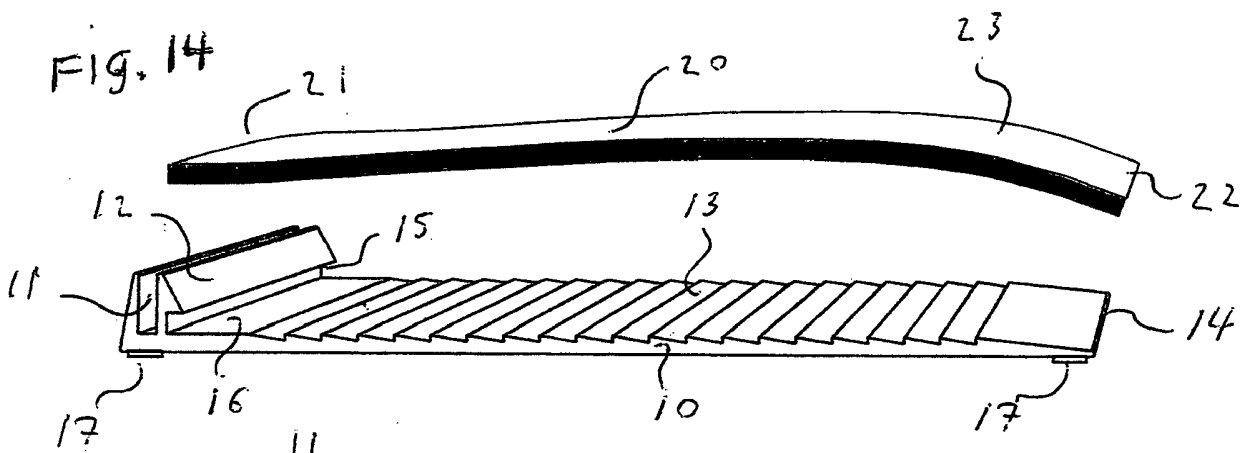
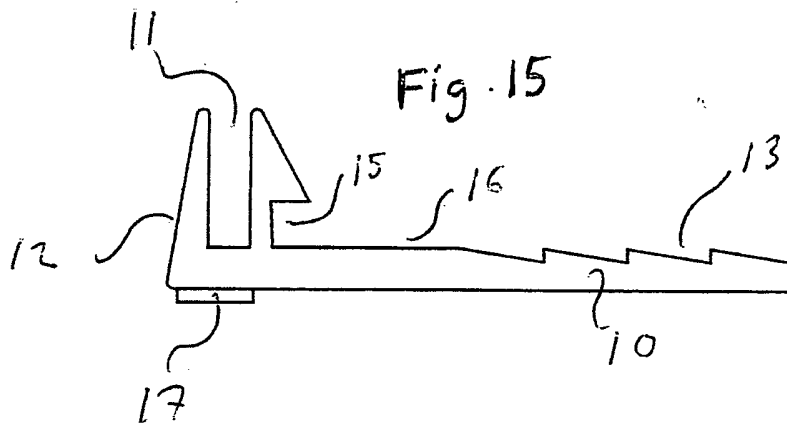

Fig. 15



NYHEDSUNDERSØGELSESRAPPORT - PATENT		Ansøgningsnummer PA 2012 00549
A. KLASSIFIKATION A 47 B 23/04 (2006.01) Ifølge International Patent Classification (IPC)		
B. UNDERSØGELSESOMRÅDE PCT-minimumsdokumentation undersøgt (klassifikationssystem efterfulgt af klassifikationssymboler) IPC&ECLA&CPC: A47B		
Undersøgt dokumentation ud over PCT-minimum DK, SE, FI, SE		
Anvendte elektroniske databaser (navnet på database og evt. søgetermer) EPODOC, WPI, FULDTEKST: ENGELSK		
C. RELEVANTE DOKUMENTER		
Kategori*	Citerede dokumenter evt. med angivelse af relevante afsnit	Relevant for krav nr.
A	DE 1932336 A1 (SOHN HEINZ) 1971.01.07 Se hele dokumentet	-
A	WO 0203836 A1 (HL DISPLAY AB) 2002.01.17 Se hele dokumentet	-
A	CH 356888 A (FUCHS PAUL) 1961.09.15 Se hele dokumentet	-
* Kategori af citerede dokumenter: "A" Dokument, der repræsenterer den kendte teknik (teknikkens stade) uden at foregribe nyhed eller væsentlig adskillelse. "D" Dokument citeret i ansøgningen. "E" Dokument, der har indleverings- eller prioritetsdato, der ligger før indleveringsdatoen for den behandlede ansøgning, men som er offentliggjort senere end indleveringsdatoen. "L" Dokument, som kan kaste tvivl over et påstået prioritetskrav, eller som citeres for at fastlægge offentliggørelsesdatoen for et andet dokument, eller citeret af andre årsager (som specificeret). "O" Dokument, der omhandler ikke-skriftlig offentliggørelse, fx foredrag, udstillinger eller film.		"P" Dokument, der er publiceret i perioden mellem prioritets- og indleveringsdatoen. "T" Dokument, som ikke er i konflikt med ansøgningen, men som er citeret for at forstå det grundlæggende princip eller teorien bag opfindelsen. "X" Særlig relevant dokument; opfindelsen har ikke nyhed eller adskiller sig ikke væsentligt fra kendt teknik, når dokumentet vurderes alene. "Y" Særlig relevant dokument; opfindelsen adskiller sig ikke væsentligt fra kendt teknik, når dokumentet kombineres med ét eller flere dokumenter af samme art, og kombinationen af disse er nærliggende for fagmanden. "&" Dokument i samme patentfamilie.
Patent- og Varemærkestyrelsen Helgeshøj Allé 81 2630 Taastrup Tlf.: +45 4350 8000 Fax: +45 4350 8001		Dato for færdiggørelsen af nyhedsundersøgelsen 19. september 2013 Nyhedsundersøgelsen er udført af Bo Gram-Nielsen

NYHEDSUNDERSØGELSESRAPPORT - PATENTAnsøgningsnummer
PA 2012 00549

C (Fortsættelse). RELEVANTE DOKUMENTER

Kategori*

Citerede dokumenter med angivelse af relevante afsnit

Relevant for krav nr.

Kategori*	Citerede dokumenter med angivelse af relevante afsnit	Relevant for krav nr.