

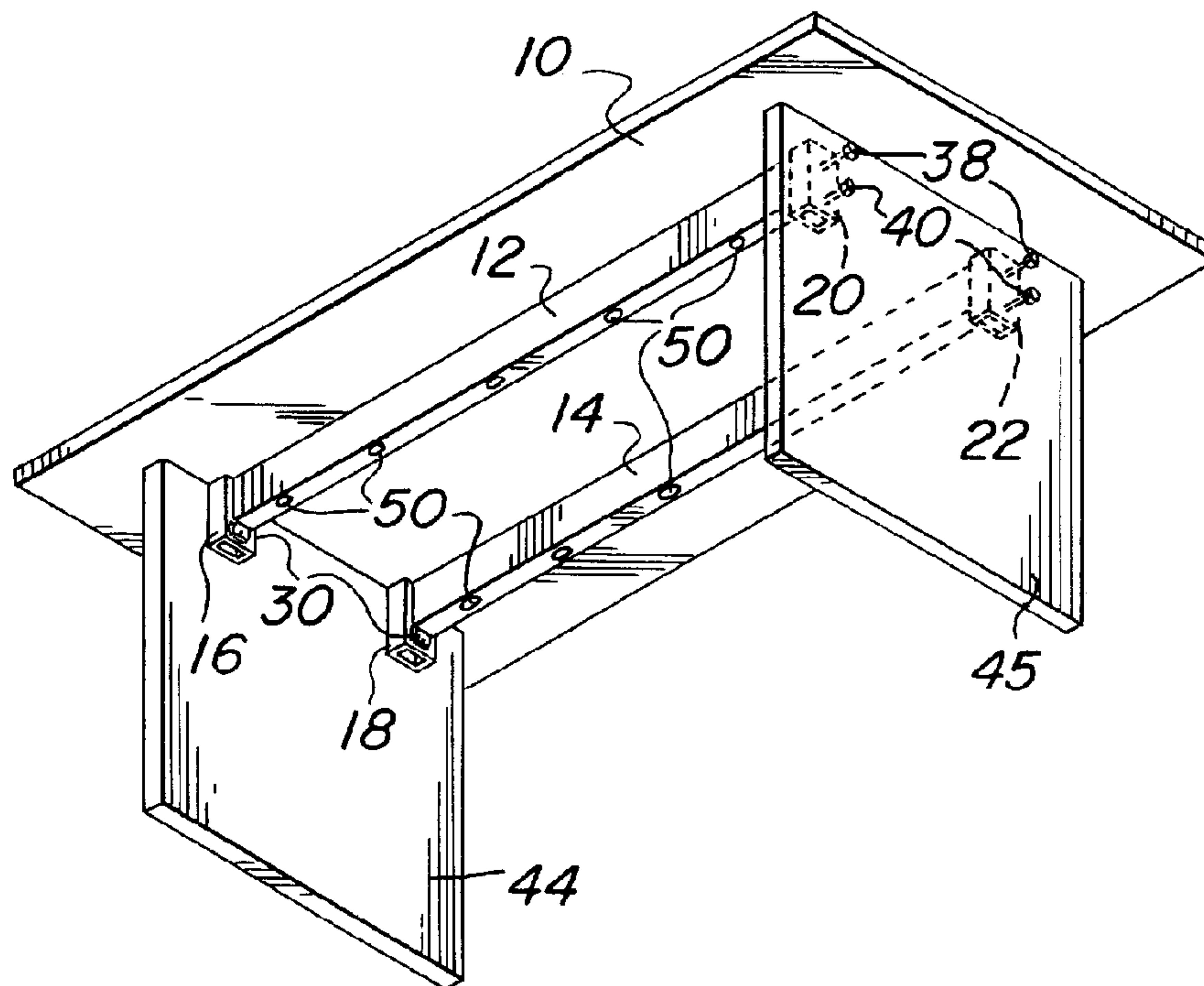

(22) Date de dépôt/Filing Date: 1992/03/20
 (41) Mise à la disp. pub./Open to Public Insp.: 1992/09/23
 (45) Date de délivrance/Issue Date: 2001/12/04
 (30) Priorité/Priority: 1991/03/22 (673,329) US

(51) Cl.Int.⁵/Int.Cl.⁵ A47B 13/00
 (72) Inventeur/Inventor:
 Thorn, William Michael, US
 (73) Propriétaire/Owner:
 THE HON COMPANY, US
 (74) Agent: SMART & BIGGAR

(54) Titre : TABLE
 (54) Title: TABLE ASSEMBLY



(57) Abrégé/Abstract:

A system for the firm, long-lived support of a table top on a pair of floor-mounting pedestals comprises a pair of parallel metal rails fastened to the underside of the table, on opposite sides of the center-line of the table top; a pair of pedestals are fastened to each of the two adjacent ends of the rails by bolts which pass through the pedestals and into internally-threaded inserts welded to vertical channel members, which channel members are in turn welded to the ends of the rails. In each such mounting assembly, the channel member has a rectangular horizontal cross-section, and extends beneath the level of the adjacent rail; one of the inserts in each mounting assembly is positioned below the level of the bottom of the associated rail. The inserts are positioned inside the channel member, with their open ends facing corresponding holes in the opposed wall of the channel member, through which holes and the mounting bolts extend into the inserts.

ABSTRACT OF THE DISCLOSURE

A system for the firm, long-lived support of a table top on a pair of floor-mounting pedestals comprises a pair of parallel metal rails fastened to the underside of the table, on opposite sides of the center-line of the table top; a pair of pedestals are fastened to each of the two adjacent ends of the rails by bolts which pass through the pedestals and into internally-threaded inserts welded to vertical channel members, which channel members are in turn welded to the ends of the rails. In each such mounting assembly, the channel member has a rectangular horizontal cross-section, and extends beneath the level of the adjacent rail; one of the inserts in each mounting assembly is positioned below the level of the bottom of the associated rail. The inserts are positioned inside the channel member, with their open ends facing corresponding holes in the opposed wall of the channel member, through which holes and the mounting bolts extend into the inserts.

PATENT

TABLE ASSEMBLYField of the Invention

This invention relates to table assemblies and particularly to apparatus for mounting a table top upon its support means.

Background of the Invention

A typical table assembly comprises a top and two or more table support means, for example four legs or two pedestals, for supporting a table top. The support means are typically fastened to the ends of rails secured to the underside of the table top.

In a conventional arrangement of this type, a pair of wooden rails extend parallel to each other along the bottom surface of the table top and are secured thereto by appropriate screws or brackets, for example. The table support means may then be secured to the ends of the rails by appropriate screws which extend through the support means and into the wood at the ends of the rails. While adequate for many purposes, such constructions provide a support for the table top which is less secure than desirable, particularly over a long period of time, partly because the screws can loosen in the wood upon repeated removal and insertion in disassembling and reassembling the table, and partly because

substantial leverage is exerted on the screws, tending to pull them or loosen them, when the table support means are subjected to torquing or pivoting forces about an axis normal to the length of the rails. Such forces exist, for example, when one moves a table about by seizing the top and dragging the table along rough and resistant surfaces.

Accordingly, it is an object of the present invention to provide a new and useful table assembly, and particularly a fastening arrangement for fastening the table support means to the table top.

Another object is to provide such a table system and fastening arrangement which is inexpensive, easy to assemble, and provides a firm, long-lasting and tight connection of the table support means to the rails.

Brief Summary of the Invention

These and other objects of the invention are attained by the provision of a table system in which a vertical channel member is secured to each end of each rail member. The rail members are preferably of metal, as are the channel members which are bonded to the ends of the rails, as by welding. To each channel member at least two threaded insert members are affixed, as by welding. The threaded portions of the inserts preferably extend horizontally within the channel members and are aligned with holes provided in the outer, opposed wall of the channel member, through which

63301-1249

holes appropriate bolts or other fastening means can be inserted to threadingly engage the insert members.

The support means, such as pedestals or legs, are secured to the rails by passing bolts or the like through the support members and through the holes in the channel members into the threaded inserts, and then tightening the bolts to hold the support means tightly against the outer flat surfaces of the channel members.

Preferably, at least one of the insert members is secured to its associated channel member at a position lower than the lower side of the associated rail member, so as to provide an increased distance between the two insert members, thereby to provide greater resistance against loosening forces due to any torque exerted on the support means about an axis normal to the rails.

In this way there is provided a table assembly in which the support means are firmly and rigidly secured to the rails so as to maintain a tight, secure connection over long periods of time. The components are easy and inexpensive to fabricate and to disassemble and reassemble.

According to one aspect, the invention may be summarized as a table support assembly, comprising: at least one metal rail securable to a table top; channel members, one bonded to each end of said at least one rail; at least two internally-threaded insert members secured within each of said channel members, each of said insert members having its

63301-1249

threaded portion extending horizontally, said channel members each having holes in their walls more remote from said rail ends, which holes are aligned with said threaded portions, at least one of said insert members on each of said channel members being at a position which is lower than the adjacent rail; table support means for supporting said table on a floor; and threaded fasteners extending through said table support means and said holes into said threaded portions of said insert members, to hold said table support means against said channel member, wherein each of said rails is open at both ends; each of said channel members has a rectangular horizontal cross-section and is welded to one of said rails; each of said insert members comprises an internally-threaded cylinder and a pair of integral ears extending radially therefrom and welded to the outside of the wall of said channel member adjacent to its associated rail end; each said cylinder is open at the end thereof more remote from the associated rail end to which it is welded, to receive a corresponding one of said fasteners; and said fasteners each comprise a bolt threaded to engage the internal threads of its corresponding insert member.

According to another aspect, the invention may be summarized as a table assembly comprising: a table top; a first hollow metal rail and a second hollow metal rail extending parallel to each other and secured to the underside of said table top; four tubular metal channel members each welded to a different end of one of said sides and said channel member having a rectangular cross-section, each of said channel members having a portion extending below its associated rail end; two insert members welded to ends of said channel members, each of said channel members having a cylindrical portion internally threaded with the axis of said threads extending

63301-1249

longitudinally, said cylindrical portion having an open end positioned within its associated channel members and facing away from the end of the insert member which is welded to its associated rail end; each said channel member having a pair of
5 holes through the sidewall being more remote from its associated rail end and aligned with said axes of its two corresponding inserts; a pair of pedestals for mounting said table top, one secured to each pair of adjacent ends of said rails; and a plurality of threaded bolts, each extending
10 through one of said pedestals, through one of said holes, and threadingly engaging the internally threaded portions of one of said inserts, thereby to hold said pedestals against said sidewalls of said channel members.

Brief Description of the Drawings

15 These and other objects and features of the invention will be more readily understood from a consideration of the following detailed description, taken in connection with the accompanying drawings, in which:

Figure 1 is a perspective view looking upward from beneath a table assembly embodying the invention;

Figure 2 is an enlarged fragmentary perspective view, looking upward from beneath, of a portion of the assembly shown in Fig. 1;

Figure 3 is a side elevational sectional view taken along lines 3-3 of Fig. 2; and

Figure 4 is a horizontal sectional view of the supporting structure of Fig. 3, taken along lines 4-4 of Fig. 3.

Detailed Description of Specific Embodiments

Turning now to the preferred embodiment of the invention shown by way of example only in the drawings, and without thereby in any way limiting the scope of the invention, Figure 1 shows a table assembly comprising a table top 10, such as for a conference table, to the underside of which top are secured a pair of longitudinally extending metal rails 12 and 14. The rails are open at their ends, and channel members 16, 18, 20 and 22 are welded to the ends of the rails, one to each rail end. Each such channel member extends downwardly below the lower end of its associated rail end, as shown, and is provided with a pair of holes such as 24 and 26 (see Fig. 3), one directly above the other, in the side face thereof more remote from the associated rail end.

Within each channel member, and aligned with these holes, are a pair of internally threaded insert members, such as 28 and 30, having integral ears such as 31, 32 which are welded to the outside of that wall of the channel member which is adjacent to the associated rail end. The threaded insert members comprise cylindrical portions such as 34, 36 which are open at the ends thereof opposite from the ends which are welded to the channels, and which contain the internal threads, so as to receive respective bolts such as 38 and 40. These bolts extend through bores such as 42, 43 in the pedestals 44, 45 which serve as support means for the table top. Appropriate washers such as 46, 47 are provided beneath the heads of the bolts. The cylindrical portions such as 34, 36 of the inserts extend inwardly of the channels through holes such as 48, 49.

By tightening the bolts such as 38, 40, the pedestals are drawn against the flat vertical outer surfaces of the channel members; the fact that one of the inserts in each vertical channel member is located below the bottom of its associated rail provides an increased vertical spacing between the adjacent insert members, providing greater resistance against torques tending to rotate the pedestal with respect to an axis perpendicular to the rail members, and thus enhancing the continued tightness and longevity of the joint.

The complete understructure under the table top is preferably assembled before it is secured to the table top. In the preferred order of assembly, the insert members are

placed in position and welded in place in the channel members; the channel members are then welded to the ends of the rails, and the complete assembly then secured to the underside of the table top 10 by screws such as 50 extending through appropriate holes in the rails into the underside of the table top.

In order to provide a smooth welded region not likely to snag the clothing of persons using the table, the channel members 16, 18, 20 and 22 are preferably somewhat wider than the rail members 12, 14, e.g. by about 1/4", to leave a 1/8" recess between the side surfaces of the rails and the adjacent channel members, in which a fillet weld such as 60 is formed.

There is thereby provided a new and useful table assembly which is inexpensive and easy to fabricate and assemble, yet provides reliable, long-lasting, secure and tight mounting of the table top to the support means.

While the invention has been shown and described with particular reference to specific embodiments in the interest of complete definiteness, it will be understood that it may be embodied in a variety of forms differing substantially from those shown and described, without departing from the spirit and scope of the invention as defined by the appended claims.

63301-1249

CLAIMS:

1. A table support assembly, comprising:
 - at least one metal rail securable to a table top;
 - channel members, one bonded to each end of said at
 - 5 least one rail;
 - at least two internally-threaded insert members
 - secured within each of said channel members, each of said
 - insert members having its threaded portion extending
 - horizontally, said channel members each having holes in their
 - 10 walls more remote from said rail ends, which holes are aligned
 - with said threaded portions, at least one of said insert
 - members on each of said channel members being at a position
 - which is lower than the adjacent rail;
 - table support means for supporting said table on a
 - 15 floor; and
 - threaded fasteners extending through said table
 - support means and said holes into said threaded portions of
 - said insert members, to hold said table support means against
 - said channel member, wherein each of said rails is open at both
 - 20 ends; each of said channel members has a rectangular horizontal
 - cross-section and is welded to one of said rails; each of said
 - insert members comprises an internally-threaded cylinder and a
 - pair of integral ears extending radially therefrom and welded
 - to the outside of the wall of said channel member adjacent to
 - 25 its associated rail end; each said cylinder is open at the end
 - thereof more remote from the associated rail end to which it is
 - welded, to receive a corresponding one of said fasteners; and

63301-1249

said fasteners each comprise a bolt threaded to engage the internal threads of its corresponding insert member.

2. A table assembly comprising:

a table top;

5 a first hollow metal rail and a second hollow metal rail extending parallel to each other and secured to the underside of said table top;

four tubular metal channel members each welded to a different end of one of said sides and said channel member
10 having a rectangular cross-section, each of said channel members having a portion extending below its associated rail end;

two insert members welded to ends of said channel members, each of said channel members having a cylindrical
15 portion internally threaded with the axis of said threads extending longitudinally, said cylindrical portion having an open end positioned within its associated channel members and facing away from the end of the insert member which is welded to its associated rail end;

20 each said channel member having a pair of holes through the sidewall being more remote from its associated rail end and aligned with said axes of its two corresponding inserts;

a pair of pedestals for mounting said table top, one
25 secured to each pair of adjacent ends of said rails; and

a plurality of threaded bolts, each extending through one of said pedestals, through one of said holes, and

63301-1249

threadingly engaging the internally threaded portions of one of said inserts, thereby to hold said pedestals against said sidewalls of said channel members.

3. The table assembly of claim 2, wherein each of said
5 inserts comprises a radially extending flange welded to its associated channel member.

4. The table assembly of claim 3, wherein each said
channel member is narrower than the end of its associated rail
end to form a recess between each rail and its associated
10 channel member, and a fillet weld in each of said recesses.

SMART & BIGGAR

OTTAWA, CANADA

PATENT AGENTS

FIG. 1

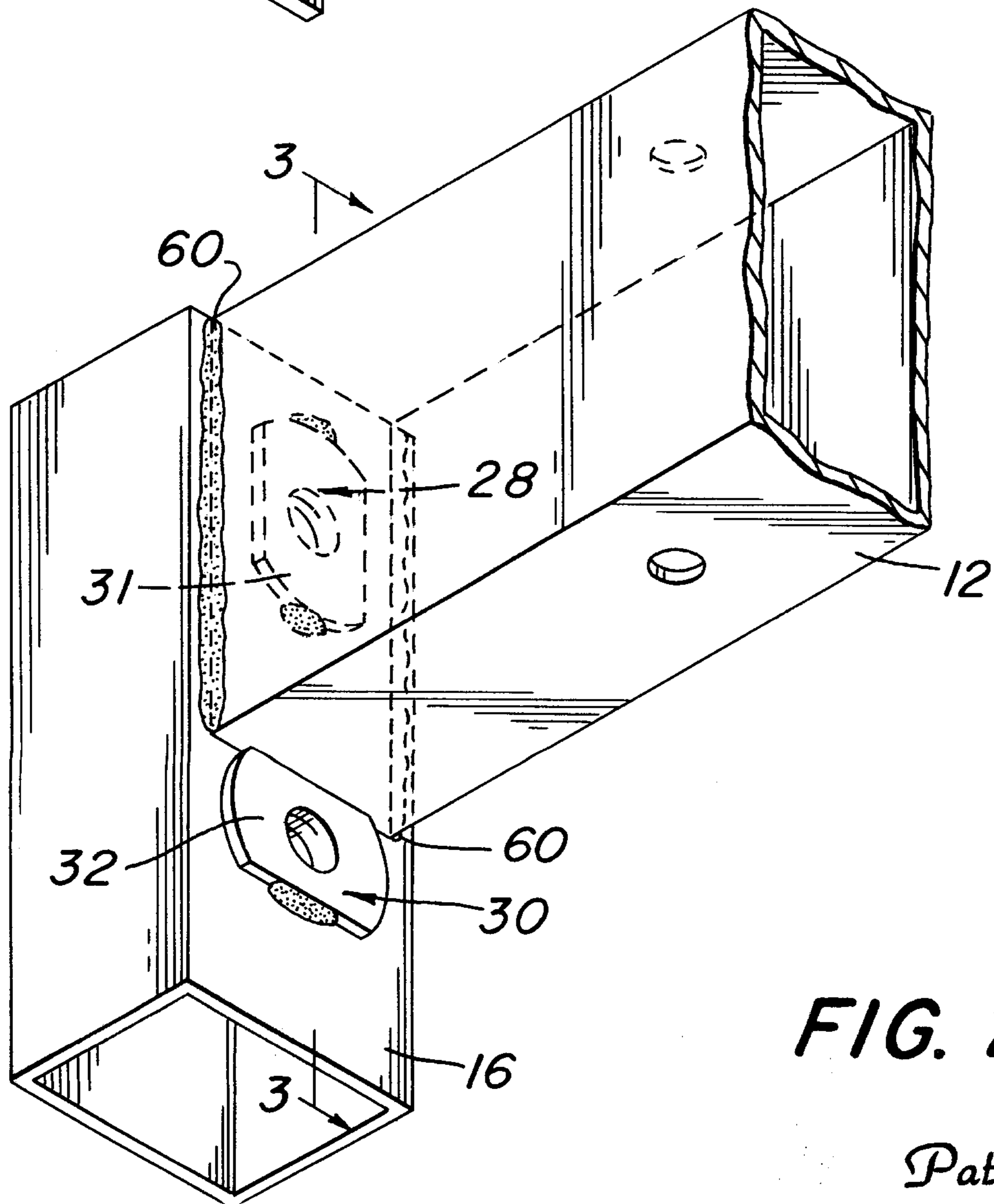
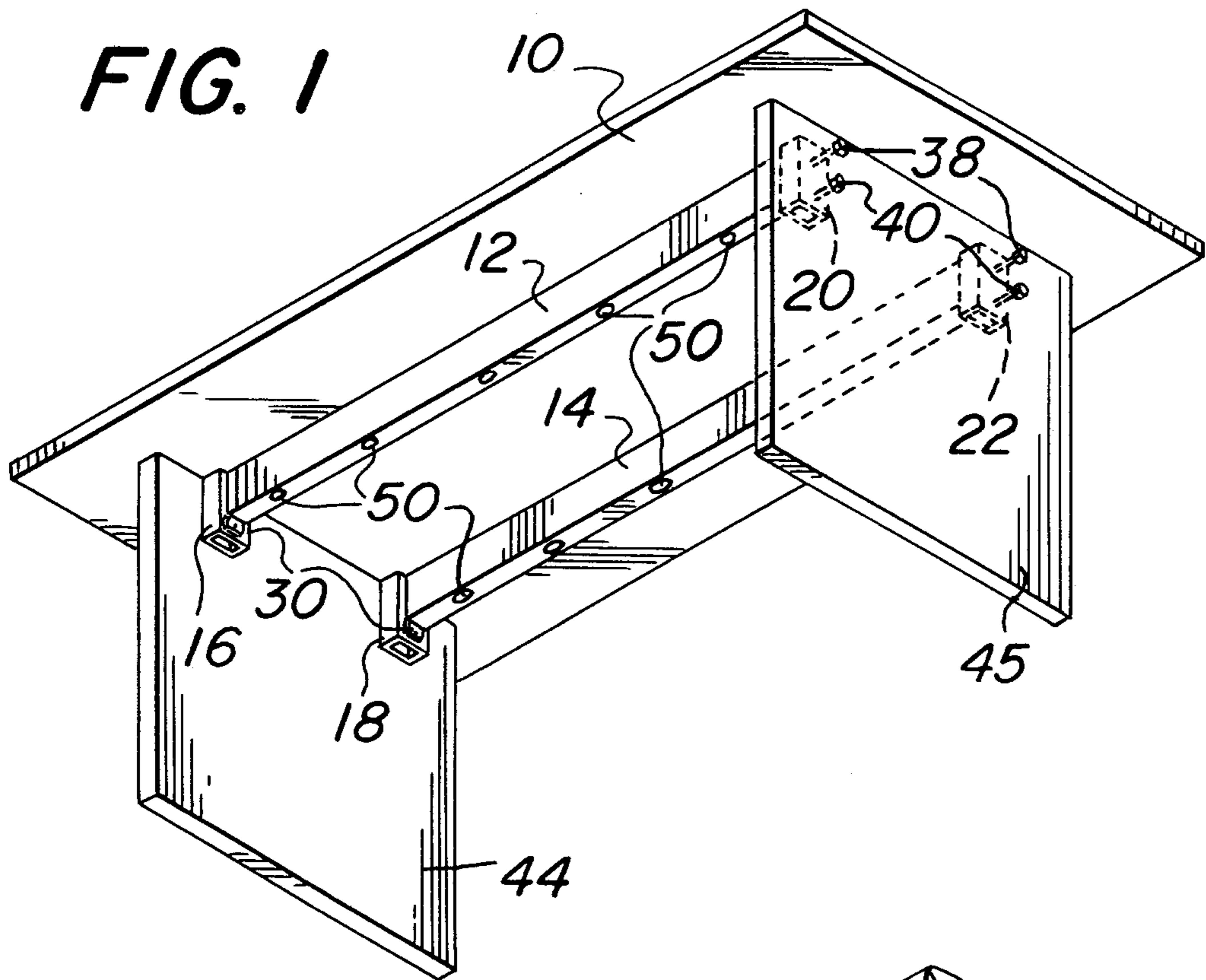

FIG. 2

