



(51) International Patent Classification:

E04D 13/076 (2006.01) E02B 5/08 (2006.01)
E04D 13/064 (2006.01)

(21) International Application Number:

PCT/US2020/040383

(22) International Filing Date:

30 June 2020 (30.06.2020)

(25) Filing Language:

English

(26) Publication Language:

English

(30) Priority Data:

62/869,053 01 July 2019 (01.07.2019) US

(71) Applicant: **GUTTERGLOVE, INC.** [US/US]; 8860 Industrial Avenue, Suite 140, Roseville, CA 95678 (US).

(72) Inventor: **LENNEY, Robert, C.**; 555 Ridgemoor Dr., Meadow Vista, CA 95722 (US).

(74) Agent: **KIDNEY, Jonathan**; Intelink Law Group PC, 6265 Greenwich Drive, Suite 201, San Diego, CA 92122 (US).

(81) Designated States (unless otherwise indicated, for every kind of national protection available): AE, AG, AL, AM, AO, AT, AU, AZ, BA, BB, BG, BH, BN, BR, BW, BY, BZ, CA, CH, CL, CN, CO, CR, CU, CZ, DE, DJ, DK, DM, DO, DZ, EC, EE, EG, ES, FI, GB, GD, GE, GH, GM, GT, HN, HR, HU, ID, IL, IN, IR, IS, JO, JP, KE, KG, KH, KN, KP,

KR, KW, KZ, LA, LC, LK, LR, LS, LU, LY, MA, MD, ME, MG, MK, MN, MW, MX, MY, MZ, NA, NG, NI, NO, NZ, OM, PA, PE, PG, PH, PL, PT, QA, RO, RS, RU, RW, SA, SC, SD, SE, SG, SK, SL, ST, SV, SY, TH, TJ, TM, TN, TR, TT, TZ, UA, UG, US, UZ, VC, VN, WS, ZA, ZM, ZW.

(84) Designated States (unless otherwise indicated, for every kind of regional protection available): ARIPO (BW, GH, GM, KE, LR, LS, MW, MZ, NA, RW, SD, SL, ST, SZ, TZ, UG, ZM, ZW), Eurasian (AM, AZ, BY, KG, KZ, RU, TJ, TM), European (AL, AT, BE, BG, CH, CY, CZ, DE, DK, EE, ES, FI, FR, GB, GR, HR, HU, IE, IS, IT, LT, LU, LV, MC, MK, MT, NL, NO, PL, PT, RO, RS, SE, SI, SK, SM, TR), OAPI (BF, BJ, CF, CG, CI, CM, GA, GN, GQ, GW, KM, ML, MR, NE, SN, TD, TG).

Declarations under Rule 4.17:

— of inventorship (Rule 4.17(iv))

Published:

— with international search report (Art. 21(3))
— with amended claims (Art. 19(1))

(54) Title: STEPPED GUTTER GUARD

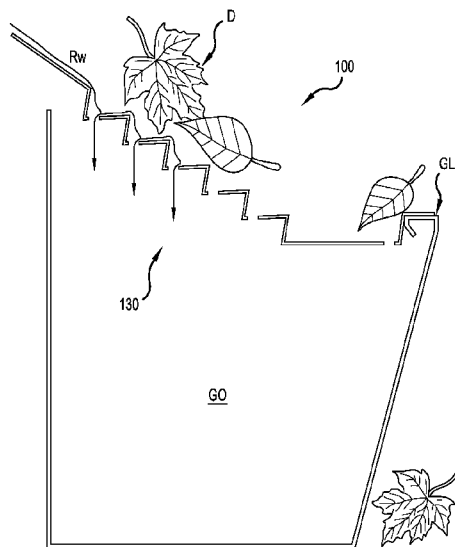

FIG.4

(57) Abstract: A self-supporting gutter guard having a roof attachment, step, trough mid gutter lip attachment portion. The step portion is composed of a plurality of connected steps having treads and risers with at least one row of step orifices disposed in one or more treads, and has at least one row of trough orifices. The trough floor is at a lower elevation than a tread of the step portion's last step and below a top of the gutter lip attachment portion. The trough and the gutter lip attachment portion share a common wall. The device provides an uneven surface for easier debris drying and removal, and is oriented at a downward angle from the roof attachment portion to the trough portion.



STEPPED GUTTER GUARD

CROSS REFERENCE TO RELATED APPLICATION(S)

[0001] This application claims the benefit and priority of U.S. Provisional Application 62/869,053 titled "One-Piece Truss Gutter Bridge," filed on July 1, 2019, wherein the above-identified application is incorporated herein by reference in its entirety.

BACKGROUND

Field

[0002] This invention relates to gutter guards and protecting gutters from having debris entering the gutter but allowing water into the gutter.

Description of Related Art

[0003] Rain gutters are generally attached to buildings or structures that have a pitched roof. The gutters are designed to collect and divert rainwater that runs off the roof. The gutter channels the rainwater (water) to downspouts that are connected to the bottom of the gutter at various locations. The downspouts divert the water to the ground surface or underground drainage system and away from the building.

[0004] Gutters have a large opening, which runs parallel to the roofline, to collect water. A drawback of this large opening is that debris, such as leaves, pine needles and the like can readily enter the opening and eventually clog the gutter. Once the rain gutter fills up with debris, rainwater can spill over the top and onto the ground, which can cause water damage to a home and erode surrounding landscapes.

[0005] A primary solution to obstruct debris from entering a gutter opening is the use of debris preclusion devices, most commonly known in the public as gutter guards. Gutter guards are also generically referred to as gutter covers, eaves guards, leaf guards or, alternatively via the more technical terms gutter protection systems, debris obstruction device (DOD), debris preclusion devices (DPD) or gutter bridge, etc. Gutter guards/DOD types abound in the marketplace and the industry is constantly innovating to find more efficient configurations that not only keep debris, such as leaves and pine needles out of the gutter, but also even tiny roof sand grit. Concomitant with these innovations are the challenges of systems that are simple (e.g., low cost, easy to fabricate, etc.) as well as systems designed to maintain effectiveness (e.g., durable, easy-to-install, minimal maintenance, etc.) in heavy weather conditions.

[0006] In view of the above, various systems and methods are elucidated in the following description, that provide innovative solutions to one or more deficiencies of the art, including designs for stepped gutter guards.

SUMMARY

[0007] The following presents a simplified summary in order to provide a basic understanding of some aspects of the claimed subject matter. This summary is not an extensive overview and is not intended to identify key/critical elements or to delineate the scope of the claimed subject matter. Its purpose is to present some concepts in a simplified form as a prelude to the more detailed description that is presented later.

[0008] In one aspect of the embodiments of this disclosure, a single piece, self-supporting gutter guard is provided comprising: a roof attachment portion configured for attachment to a roof or building or roof-side end of a prospective gutter; a step portion, integrally

connected to the roof attachment portion, composed of a plurality of connected steps with corresponding treads and risers, wherein at least one of the connected steps has at least one row of step orifices disposed in its tread; a trough portion integrally connected to a last step of the step portion, having at least one row of trough orifices disposed therein, wherein a floor of the trough portion is at a lower elevation than a tread of the last step; and a gutter lip attachment portion integrally connected to the trough portion, configured for attachment to a lip of the prospective gutter, wherein the floor of the trough portion is below a top of the gutter lip attachment portion, and wherein the trough and the gutter lip attachment portion share a common wall; wherein the step portion is self-supporting, provides an uneven surface for easier debris drying and removal, and is oriented at a downward angle from the roof attachment portion to the trough portion.

[0009] In another aspect of the embodiments of this disclosure, the above gutter guard is provided, wherein the roof attachment portion includes a terminal section that is at an angle from a plane of the roof attachment portion; and/or further comprising riser orifices disposed in the at least one of the connected steps; and/or wherein the step orifices are partially disposed in the tread and partially disposed in a riser of an adjacent step; and/or wherein the step orifices are at least one of non-circular in shape, arranged in a plurality of rows, arranged in a plurality of offset rows, and proximal to a riser of an adjacent step that is on a roof attachment portion side of an orificed tread; and/or wherein the trough orifices are at least one of non-circular in shape, arranged in a plurality of rows, arranged in a plurality of offset rows, proximal to a riser of an adjacent step that is on a roof attachment portion side of the orifices, proximal to the common wall, disposed in the common wall, and disposed at a junction between the trough's floor and the common wall; and/or, wherein all of the steps in the step portion have orifices; and/or wherein

the trough portion is wider than at least a width of a step in the step portion; and/or wherein an outside corner of the at least one of the connected steps partially overhangs an orifice in a lower adjacent step's tread; and/or wherein an outside corner of the at least one of the connected steps completely overhangs an orifice in a lower adjacent step's tread; and/or wherein an angle of an outside corner and inside corner of the at least one of the connected steps is less than 90 degrees; and/or wherein the step portion's downward angle is between 15 – 45 degrees; and/or wherein a tread length of the treads is greater than a riser length of the risers; and/or wherein one or more steps of the at least one of the connected steps is at least one of a different size and different shape than one or more other steps of the at least one of the connected steps; and/or wherein one or more steps of the at least one of the connected steps has at least one of a different inside corner and outside corner angle than one or more other steps of the at least one of the connected steps; and/or wherein the last step is at least one of larger, different in shape and different in angle than a first step of the step portion; and/or further comprising a barrier in the trough portion; and/or wherein the barrier is at least one of raised and recessed; and/or wherein the recessed barrier has an orifice in a bottom thereof; and/or wherein barrier is formed from the floor of the trough portion; and/or the barrier is shaped as at least one of a circle, plurality of circles, rectangle, arrow head, arc, and starburst. ; and/or wherein the orifices are perforations in a material of the step portion and trough portion; and/or wherein the plurality of connected steps are at least 3 or more steps; and/or wherein the gutter lip attachment portion further comprises a terminal end extending past the lip of the prospective gutter, and being downwardly oriented.

[0010] In yet another aspect of the embodiments of this disclosure, a self-supporting gutter guard is provided, comprising: a roof attachment portion; a step portion connected to the roof attachment portion, composed of a plurality of connected steps with corresponding treads

and risers, wherein at least one of the connected steps has at least one row of step orifices disposed in its tread; and; a gutter lip attachment portion connected to the step portion.

[0011] In yet another aspect of the embodiments of this disclosure, a self-supporting gutter guard formed from a single piece of material, comprising: a roof attachment portion; a step portion connected to the roof attachment portion, composed of a plurality of connected steps with corresponding treads and risers, wherein at least one of the connected steps has at least one row of step orifices disposed in its tread; and a gutter lip attachment portion connected to the step portion.

[0012] These and other features and advantages of this invention are described in, or are apparent from, the following detailed description of various exemplary embodiments of the devices and methods according to this invention

BRIEF DESCRIPTION OF THE DRAWINGS

[0013] Various exemplary embodiment of this invention will be described in detail, with reference to the following figures, wherein:

[0014] Fig. 1 is a side view illustration of an installed prior art gutter guard.

[0015] Fig. 2 is a perspective view illustration of an exemplary gutter guard.

[0016] Fig. 3 is a side view illustration of the exemplary gutter guard of Fig. 2 over a gutter connected to a roof.

[0017] Fig. 4 is an illustration of an installed exemplary gutter guard with debris flowing over it.

[0018] Fig. 5 is a close-up illustration of a section of the step portion for an exemplary single piece gutter guard.

[0019] Fig. 6 is an illustration of alternative step outside corners for an exemplary single piece gutter guard.

[0020] Fig. 7A is an illustration of an exemplary gutter guard with a variation of the tread orifice location.

[0021] Fig. 7B is an illustration of an exemplary gutter guard with staggered rows of tread orifices.

[0022] Fig. 7C is an illustration of an exemplary gutter guard, wherein the tread orifices are of different sizes.

[0023] Fig. 7D is an illustration of an exemplary gutter guard, wherein the tread orifices are shared at the riser-tread junction and reduced orifices.

[0024] Fig. 7E is an illustration of an exemplary gutter guard, wherein the tread orifices are of different shapes.

[0025] Fig. 7F is a perspective view of an installed exemplary gutter guard, wherein the orifices are also disposed in the risers.

[0026] Fig. 8A is an illustration of an exemplary gutter guard with an additional "row" of trough orifices.

[0027] Fig. 8B is an illustration of an exemplary gutter guard with another "row" trough orifices.

[0028] Fig. 9A is a perspective view of an installed exemplary gutter guard with trough orifices.

[0029] Fig. 9B is a perspective view of an installed exemplary gutter guard with laterally disposed trough orifices.

[0030] Fig. 9C is a perspective view of an installed exemplary gutter guard with floor and laterally disposed trough orifices.

[0031] Fig. 9D is a perspective view of an installed exemplary gutter guard with corner disposed trough orifices.

[0032] Fig. 9E is a perspective view of an installed exemplary gutter guard with laterally disposed rectangular trough orifices and floor orifices.

[0033] Fig. 9F is a perspective view of a modification of the embodiment of Fig. 9E, with screened orifices.

[0034] Fig. 10 is a side view illustration of an installed exemplary gutter guard at a shallow installation angle.

[0035] Fig. 11 is a side view illustration of an exemplary gutter guard at a larger installation angle.

[0036] Fig. 12 is a side view illustration of an installed exemplary gutter guard at a greater installation angle.

[0037] Fig. 13A is an exploded side view of a step portion of an exemplary gutter guard, with an installation slope angle of approximately 45 degrees.

[0038] Fig. 13B is an exploded side view of a step portion of an exemplary gutter guard, with an installation slope angle of approximately 35 degrees.

[0039] Fig. 13C is an exploded side view of a step portion of an exemplary gutter guard, with an installation slope angle of approximately 15 degrees.

[0040] Fig. 14A is an illustration of an exemplary gutter guard with steps having varying lengths.

[0041] Fig. 14B is an illustration of another exemplary gutter guard with steps having varying lengths.

[0042] Fig. 14C is an illustration of another exemplary gutter guard with steps having varying lengths.

[0043] Fig. 14D is an illustration of another exemplary gutter guard with steps having varying lengths.

[0044] Fig. 14E is an illustration of an exemplary gutter guard with steps having varying angles.

[0045] Fig. 14F is an illustration of an exemplary gutter guard with small step sizes.

[0046] Fig. 14G is an illustration of an exemplary gutter guard with an embedded enlarged step.

[0047] Fig. 14H is an illustration of an exemplary gutter guard with an arched configuration.

[0048] Fig. 15 is an illustration of an exemplary gutter guard with a trough barricade.

[0049] Fig. 16 is a side view illustration of the exemplary gutter guard of Fig. 15.

[0050] Fig. 17 is an illustration of an exemplary gutter guard with a recessed trough barricade and several variations.

[0051] Fig. 18 is a side view illustration of an exemplary gutter guard showing a possible step size variation and a raised and recessed barricade.

[0052] Fig. 19 is an illustration of a barricade formed of a cluster of circular shapes.

[0053] Fig. 20 is an illustration of another barricade shaped as arrow heads.

[0054] Fig. 21 is an illustration of another barricade shaped as crescents.

[0055] Fig. 22 is an illustration of another barricade shaped as a disc.

[0056] Fig. 23 is an illustration of another barricade shaped as a starburst.

DETAILED DESCRIPTION

Introduction

[0057] It should be appreciated that the most commonly used term to describe a debris obstruction (or preclusion) device (DOD) for a rain gutter is gutter guard. However, as stated above, alternate terms are used in the industry (generally from product branding), denoting the same or essentially same purpose of preventing or obstructing the entrance of external debris (e.g., non-water material) into the rain gutter, whereas the gutter can be protected so as to operate effectively. Thus, recognizing the layman may interchangeably use these terms to broadly refer to such devices, any such use of these different terms throughout this disclosure shall not be interpreted as importing a specific limitation from that particular “brand” or “type” of gutter device. Accordingly, while a DOD or gutter bridge may be a more technically accurate term, unless otherwise expressly stated, the use of the term gutter guard, gutter cover, leaf guards, leaf filter, gutter protection systems, gutter device, gutter guard device, and so forth, may be used herein without loss of generality.

[0058] Many conventional gutter guard devices are made of a single planar piece of perforated sheet of aluminum and are designed to be installed in a primarily horizontal arrangement relative to the gutter. For example, Fig. 1 is an illustration of a commonly used conventional gutter guard device 20. The horizontal installation over the gutter G generally creates a flat surface 22 extending from the building B to the gutter lip 28 (the outer edge of the gutter). This flat surface 22 tends to encourage debris to accumulate on the gutter guard 20. This accumulation can and often clogs the holes 25 on the gutter guard 20, preventing water

from penetrating the gutter guard 20 into the gutter G. Also, these types of conventional, flat, horizontal, gutter guards 20 can cause rainwater to wick back under roof shingles S once debris has accumulated on the guard 20. This wicking can cause extensive water damage to the building B. Still further, with the accumulation of debris and rainwater not being able to readily flow through the guard 20 and into the gutter G, the rainwater can flow across the guard 20 to the gutter lip 28, and then undesirably over the gutter G.

[0059] Designs of gutter guard devices are in a constant battle of balancing the size of the holes in the surface of the device so that water can be diverted into the gutter without having the holes be too large to allow debris to enter the gutter. Also, supporting the gutter guard over the gutter is challenging, wherein multiple support structures are also used. As debris entrance is undesired, conventional gutter guard devices tend to have a great number of small diameter holes per square inch. However, this design balance generally ends up reducing the rigidity of the device, often requiring separate supporting structures. Further, small diameter holes are easier to be obstructed with micro-debris and this eventually causes the water to flow over the holes and fall off the end of the gutter guard.

[0060] Conventional gutter guard devices have to be manufactured in multiple different sizes to fit generally used gutter sizes; a different sized gutter guard for each gutter size. Further, conventional guards are not readily modifiable to fit various building configurations.

Stepped Gutter Guards

[0061] In view of the above challenges for gutter guards, exemplary stepped designs are described herein including one-piece design(s) which are able to fit a 4", 4.5", 5" or 6" gutter, for example. As a "one-size fits" design is easier to stock on store shelves, retailers and sellers will appreciate the space savings. As the exemplary design is capable of fitting commonly sized

gutters, homeowners will not need to climb to the roof to measure their gutter widths.

Contractors do not have to be burdened with carrying multiple size guards to the job site. In various embodiments, the exemplary device's back section can be made to be flexible, thus able to be "bent" into a variety of angles to fit different roof/gutter mounting situations.

[0062] The below Figs. will have illustrations of various exemplary embodiments, however, it is noted that portions of the illustrations may not be to scale. That is, certain described elements may not be appropriately scaled with respect to other described elements. Or the described orientation or angles may not be as shown or if shown are not the exact value described. For example, certain cross sectional views or cut-away, for ease of viewability, are shown as a gap in the profile, the gap indicating the orifice or break in the structure. Whereas, the gap would not be traditionally shown in a true cross sectional view. Further, lengths of certain elements, tread or riser for example, may not be true to scale, as well as the angles that define them.

[0063] Fig. 2 displays a perspective view of an exemplary gutter guard device 100. Fig. 3 shows a partial cut-away side view of the exemplary device 100, installed on a gutter G, attached to building B, having a roof R. (It is noted here that Fig. 3's cut-away view illustrates the orifices as breaks in the continuity of the surface, but it is understood that this is done simply for ease of viewing.) The device 100 includes a roof attachment portion 110 connected to a step portion 130, connected to a trough portion 160 and connected to a gutter lip attachment portion 190. The device 100 can be made from a single piece of material, if so desired, or of several pieces joined together. For the embodiments described herein, portions 110, 130 and 190 principally define the exemplary device 100, with optional portion 160 added for other

embodiments of the exemplary device 100. For ease of explanation, the following discussion will describe the exemplary device 100 with all the portions 110, 130, 160 and 190.

[0064] The roof attachment portion 110 includes an attachment portion riser 114 and an attachment tread 116. The “roof-side” of attachment portion riser 114 can be terminate with an optional attachment section 112, which can be attached to a side of building B. While Figs. 2 and 3 show optional attachment section corner 112 as a lip, it is understood that it can be curled, a bead, tapered, U or L-shaped, bent, etc., according to design preference. For example, all or part of attachment section corner 112 and/or attachment tread 116 may be bent into a desired angle. When the device 100 is in use, attachment tread 116 can simply be slid under a roof’s singles or in some applications it can be bent to conform with and match the building B so that it can be fastened to the building B and/or the gutter G. In various embodiments herein, attachment tread 116 (at for areas neighboring the roof) is designed to be solid, without holes. If attachment tread 116 is sufficiently wide to have a region hanging over the gutter’s G opening, holes may be devised in that region to allow drainage into the gutter G.

[0065] Attachment portion riser 114 connects to step portion 130, which includes a plurality of steps 132. Each of steps 132 has a plurality of orifices 134 formed therein. Step portion 130 is integrally connected to and disposed between roof attachment portion 110 and trough portion 160. The size of steps 132 within step portion 130 may be uniform between steps 132 or may vary, according to design preference.

[0066] Each step 132 of step portion 130 has a respective tread 140 and riser 150. In various embodiment, step orifices 134 are formed in tread 140 of each of steps 132, and usually (but not necessarily) disposed toward a roof-side end of each tread 140. It is expressly understood that the orifices shown in this disclosure can be circular, oval, rectangular, slots,

ports, etc. and are not restricted to any particular shape. Further, the orifices can be formed in one or more rows or arrangements and formed by punching, machining, molding, and so forth. The orifices can also be of different sizes, types, shapes, etc. for different steps within step portion 130. In some embodiments, the orifice(s) or row of orifice(s) can be substituted with a segmented slots parallel to the tread.

[0067] In the embodiment shown in Fig. 2, a density of the step orifices 134 was approximately 18 orifices per linear foot. However, it is expressly understood that other densities, shapes, arrangements and locations of the step orifices 134 are possible, without departing from the spirit and scope of this disclosure.

[0068] Optional trough portion 160 is integrally connected to and disposed between step portion 130 and gutter lip attachment portion 190. Trough portion 160 is joined to step portion 130 via riser 150 of step portion 103's last step. Trough portion 160 includes a trough tread 164 and a gutter lip side trough riser 166. Trough tread 164 connects to trough riser 166 at junction or corner 168 which is below gutter lip attachment portion 190. Accordingly, trough portion 160 or at least corner 168 is below step portion 130 and/or gutter lip attachment portion 190. Angle E is formed on the upper surface of trough portion 160 between tread 164 and riser 166. In various embodiments, the angle E can range between 45 degrees to 135 degrees.

[0069] Trough portion 160 can include a plurality of trough orifices 162, shown here as disposed to one side of trough portion 160, but it is understood they can be disposed in a different arrangement as well as at other sections or locations within trough portion 160 or gutter lip attachment portion 190. In the embodiment shown here, the location and arrangement of the trough orifices 162 are such that the trough tread 164 can flex (in some small degree) so as to act as a spring board to help bounce leaves, pine needles and debris off the trough tread 164.

[0070] Trough riser or wall 166 connects to gutter lip attachment portion 190 at junction or corner 169. In some embodiments, the trough riser 166 may be less than $\frac{1}{4}$ the width the trough tread 164. In other embodiments, the trough riser 166 may be greater than $\frac{1}{4}$ the width the trough tread 164. It will be appreciated that the trough 160 and/or riser 166 may have a curved profile rather than an angular or flat profile. Gutter lip attachment portion 190 includes at least a lip tread 192. Lip tread 192 is configured to be fastenable to the gutter when the device 100 is in use. It will be appreciated that a variety of conventional fasteners may be utilized to fasten lip tread 192 to the gutter lip, such as but not limited to screws, rivets, double sided tape, etc. As stated above, trough portion 190 may be optional, being proxied with the last step of the step portion 130, which may have a last step configuration analogous or similar to the trough tread 164, but perhaps without a trough riser 166.

[0071] Fig. 3 shows a partial side view of the exemplary device 100, installed on a gutter G. The gutter G is attached to building B, having a roof R. The building B, the roof R and the gutter G are represented in this Fig. without great detail as any conventional elements of those items may be utilized and are only shown here to show application for the exemplary devices. It will be appreciated that the roof R can be any type of conventional roofing material, including asphalt shingles, tile roofing, etc. It will further be appreciated that the gutter G is configured to capture liquid, generally rainwater RW, that flows down the roof R and into the gutter G. The gutter G has a gutter lip GL. The exemplary device 100, when in use is disposed above the gutter opening GO. The device 100 is operably configured to span over the entire gutter opening GO. The device 100 extends from the roof R to the gutter lip GL. The device 100, along with other similar embodiments, will allow rainwater RW to pass from a top surface of the device 100 through the device 100 and into the gutter G, while preventing a substantial amount of debris

from falling into the gutter G. Additionally, the device 100, along with other similar embodiments will enable nearly all of the rainwater RW to fall into the gutter G and not run over the gutter lip GL. The device 100 is shown in this Fig. is installed to the building B and gutter G with a near horizontal slope.

[0072] Mid-section of Fig. 3 shows a body of steps 130 including a first connecting step 136 joined to at least one middle step(s) 137 joined to a second connecting step 138. First connecting step 136 is disposed adjacent to roof attachment portion 110. Second connecting step 138 is disposed adjacent to trough portion 160. Second step 138 is closer in proximity to the gutter lip GL than the remaining steps 130. Second connecting step's 138 riser 150 is adjacent trough portion 160. The at least one middle step(s) 137 is shown in this example as having three inner steps. However, the number of inner steps can be varied as desired.

[0073] Each step of steps 130 has a step outside corner 154. Step outside corner 154 is formed by a top of a riser 152 of one step and an outside portion 153 of the tread of the adjacent step. As shown below, the step outside corners 154 may be formed at an acute angle causing one or more the respective treads and risers to be tilted or offset. Each step of steps 130 further includes a step inside corner 157. The step inside corner 157 is formed by a bottom 155 of a riser of one step and an inside portion 156 of the tread of the adjacent step. Orifices 134 are typically disposed proximal to the step inside corners 157. The step inside corners 157 may be formed at an acute angle causing one or more the respective risers and adjoining treads to be offset or tilted. That is, in some embodiments, step outside corners 154 may "extend" over and overhang past a neighboring step inside corner 157 under it (to form a Z-like shape, for example). Conversely, in other embodiments, the step corner angle(s) may be obtuse to cause

step outside corners 154 to be slightly retarded or "short" so as to not overhand the neighboring step inside corner 157 under it.

[0074] Fig. 4 is an illustration of an installed exemplary device 100, with debris flowing over it. When the device 100 is in use, the downward arrangement of step portion 130 will cause rainwater RW to generally roll through the orifices within the steps and into the gutter opening GO. However, the shape and or angling of the step portion 130 will also generally enable leaves, pine needles and other debris D to simply skip down the steps toward the gutter lip GL. A majority of the rainwater RW from the roof will fall through the orifices in the step portion 120. Thus, less rainwater RW will arrive at the trough portion. Since rainwater falling off the gutter lip GL is not desirable, it is advantageous to have rainwater RW fall through the device 100 and into the gutter closer to the roof side rather than closer to the gutter lip GL.

[0075] Also of note is the lack of separate support structures in this design, wherein the device 100 is self-supporting due to the stepped nature and judicious placement of the orifices.

[0076] Fig. 5 is a close-up illustration of a section of the step portion 130, for one possible embodiment, wherein three (of possibly less or more) steps 132 are shown. Each step 132 includes an angle A formed between riser 150 and tread 140. The step portion 130 also includes an angle B between adjacent steps. Angle B is formed between the tread 140 of one step and the riser 150 of the adjacent step. Angle A is the interior angle for the step outside corners 154. Angle B is the exterior angle for the step inside corners 157.

[0077] As illustrated in Fig. 5, angle A can be an angle 90 degrees or less, even down to 5 degrees, if so desired. In various experimental designs, angles of between 50 - 80 degrees were evaluated, as well as angles between 60 and 75 degrees. For the embodiment shown in Fig. 5, Angle A is set at approximately 87 degrees in perspective to tread 140 and riser 150.

[0078] Angle B can also be an angle 90 degrees or less, even down to 5 degrees, if so desired. In various experimental designs, angles of between 50 - 80 degrees were evaluated, as well as angles between 60 and 75 degrees. For the embodiment shown in Fig. 5, Angle B is set at approximately 87 degrees in perspective to tread 140 and riser 150.

[0079] Orifices 134 are shown as formed in the steps 132 along the step inside corners 157. With this arrangement, when the device 100 is in use on a gutter, the device 100 enables the outside corner 154 of one step to “protect” the orifices 134 formed in the adjacent lower step from debris falling directly into the lower step’s orifice 134. This is possible because debris, traveling on the top of a tread 140, will usually have a given momentum from the water it is traveling on. This momentum will launch the debris or the debris will fall “forward” onto the lower next outside corner. See Fig. 4, for example. The width and tilt of the tread 140 will contribute to the effectiveness of debris transitioning off the device 100, as well as the height of riser 150 and overall slope of the step portion 130. For example, from experimental embodiments, it was found designs with tread lengths greater than riser heights tended to perform better with respect to water drainage and debris preclusion. In fact, improved results were found when the tread-to-riser ratio was at least 2:1.

[0080] The amount of “protection” afforded to the orifices 134 is based on the A & B angles, but also on a separation distance C between an orifice centerline 135 and vertical line 158 from the neighboring step outside corner 154. The separation distance C can be a positive value (e.g., orifice centerline 135 is displaced towards a gutter lip side of the device 100, further away from the vertical line 158), or can be a negative value (e.g., the orifice centerline 135 is displaced towards a roof side of the device 100 closer to the vertical line 158, or even past it). For the latter case, the step outside corner 154 will “overhang” the neighboring orifice 134. For

experimental designs, using a device 100 sized to cover a 5 inch wide gutter, with a run-to-rise ratio of 2, it was found that a value of C approximately 0.166 inches (with 0.25 inch variability) was well suited for debris removal, while providing a high water drainage result.

[0081] Fig. 6 is an illustration of sample alternative step outside corners. For example, the first image shows a rounded corner 154A. The second image shows a micro-stepped corner 154B. And the third image shows a rounded-micro-stepped corner 154C. These illustrations are provided to show that the outside corner does not need to have a defined edge but can be smooth or blunt or other shaped. For example, the edge can be chamfered or any variation of a shape thereof.

[0082] As stated above, the various orifices may be disposed at other locations in the exemplary device. For example, Fig. 7A is an illustration of an exemplary embodiment 710, wherein the tread orifices 714 are disposed closer to a gutter lip side end of the respective tread.

[0083] Fig. 7B is an illustration of an exemplary embodiment 720, wherein the tread orifices 724 are arranged as two staggered rows on the step treads.

[0084] Fig. 7C is an illustration of an exemplary embodiment 730, wherein the tread orifices are of different diameters or sizes 731, 733. It should be appreciated that the respective shapes may be different than shown.

[0085] Fig. 7D is an illustration of an exemplary embodiment 735, wherein the tread orifices are shared with the riser (disposed at the riser-tread junction) 736. Additionally, the reduction in number and increase in spacing is seen in riser-tread orifice 737. Similarly, tread orifices 738 and 739 show a reduction in number and increase in spacing.

[0086] Fig. 7E is an illustration of an exemplary embodiment 740, wherein the tread orifices are of different shapes 744, 745.

[0087] Fig. 7F is a perspective view of an installed exemplary embodiment 750, wherein the orifices 759 are also disposed in the risers.

[0088] Fig. 8A is an illustration of an exemplary embodiment 810, wherein an additional "row" of trough orifices 813 is positioned on an opposite side of the trough from gutter lip side trough orifices 812.

[0089] It should be appreciated that the various exemplary embodiments shown here demonstrate orifices disposed in each tread, wherein the presences of the orifices improve the water drainage factor of the "orificed" treads on the gutter guard. However, it is understood that in some embodiments, one or more treads may not be orificed, or if they are present, the orifices may be limited in amount. Therefore, one or more embodiments are possible where alternating treads, or a sequence of treads, or combination of alternating sequence of treads, for example, may be orificeless, understanding this can be a design choice.

[0090] Fig. 8B is an illustration of an exemplary embodiment 820, wherein another "row" of trough orifices 822 is positioned between the trough orifices 812 and 813 shown in Fig. 8A.

[0091] Fig. 9A is a perspective view of an installed exemplary embodiment 900, showing a set of trough orifices 902 disposed in the floor 970 of trough portion 960.

[0092] Fig. 9B is a perspective view of an installed exemplary embodiment 910, showing trough orifices 914 laterally disposed in the gutter lip side riser or wall 981 of the trough portion 961. This embodiment shows these trough orifices 914 as the only orifices in the trough portion 961. It should be appreciated that side wall trough orifices 914, in this and other embodiments, may be disposed at any height, orientation, arrangement, etc. within the side wall of the trough

portion. However, locations nearer to the floor of the trough portion are understood to provide earlier and more effective drainage.

[0093] Fig. 9C is a perspective view of an installed exemplary embodiment 920, showing laterally disposed trough orifices 924 in side wall 982 of the trough portion 961, as well as trough orifices 922 in the floor 972 of the trough portion 962.

[0094] Fig. 9D is a perspective view of an installed exemplary embodiment 930, showing trough orifices 932 disposed in the corner formed by floor 973 and side wall 983 of the trough portion 963.

[0095] Fig. 9E is a perspective view of an installed exemplary embodiment 940, showing laterally disposed trough orifices 944 having a rectangular “window” shape inside wall 984 and orifices 942 in floor 974 of the trough portion 964.

[0096] Fig. 9F is a perspective view of a modification of the embodiment of Fig. 9E, wherein the windows 954 are screened to prevent debris entrance.

[0097] It should be appreciated that the above illustrations show a trough width that is significantly greater than a neighboring step width. However, in some embodiments, the trough width may be equivalent to or less than a width of the neighboring step width, this being a design variable. Nonetheless, for various experimental designs, the trough width was tested at a width of approximately 1 inch for a 5 inch gutter spanning gutter guard.

[0098] As should be apparent, the above Figs. illustrate only a small set of various possible modifications to the embodiment shown in Fig. 2. Therefore, it is understood that the above examples are not to limit the breath of the possible embodiments, and that other changes and modifications may be made without departing from the spirit and scope of this disclosure.

[0099] Fig. 10 is a side view illustration of an exemplary embodiment 1000 installed over a gutter G. It is noted here that the “installation” slope A of the device 1000 is very shallow, being the roof attachment portion 1010 is disposed under the roof R.

[0100] Fig. 11 is a side view illustration of an exemplary embodiment 1100 with a larger “installation” slope B.

[0101] Fig. 12 is a side view illustration of an exemplary embodiment 1200 installed over a gutter G, wherein the “installation” slope C is greater than the slopes shown in Figs. 10 and 11.

[0102] The embodiments of Figs. 10, 11, and 12 are the same device, however, positioned at different angles of installation. These Figs. illustrate the ability of the exemplary device to be installed at different angles while still preserving its gutter guard characteristics. Of particular note is that the exemplary device may flex to accommodate different angles, as well as different size gutters, wherein the flexing does not significantly affect the overall characteristics of the device.

[0103] The design of the exemplary gutter guard allows it to fit on practically any size and type of gutter. An installer can easily modify or adjust the overall depth (from the perspective of the front of gutter to back of gutter) so it will fit whatever gutter desired to be installed on. The exemplary gutter guard also has inherent qualities that allows it to be flexible as well as fit snugly over the gutter.

[0104] Fig. 13A is an exploded side view of a step portion 1300 of an exemplary device, having an installation slope angle 1362 of approximately 45 degrees. Step outside corner 1354 protrudes over and covers a portion of the lower orifice 1334 disposed adjacent to the step outside corner's riser 1352. With such an overhang acting to shield the orifices 1334, the orifices

1334 can be larger than with a non-overhang design. With larger orifices 1334, a greater volume of rainwater can be directed into the gutter.

[0105] The step's treads 1340 can be reverse sloped (tilted back) by a tilt angle 1345 of approximately 10 degrees down from the horizon, given the approximate 45 degree installation angle. This arrangement elevates the outside corners to cause rainwater to be forced back towards the orifices, and with several orificed steps, it is unlikely rainwater will ever reach the gutter lip. Because the combination of steps act like stairs, debris will progressively fall "down" onto the next step. The greater the tilt angle 1345, the more water will be drained in the earlier steps of the step portion 1300.

[0106] Therefore, it will be appreciated that the exemplary devices enable rainwater to more readily flow into the gutter at the roof side end of the device, thus reducing the possibility of rainwater falling off the gutter lip side. Additionally, because there is a natural slope in the stair-step design, exemplary embodiments will be highly effective at allowing debris to move across and fall off the gutter.

[0107] Fig. 13B is an exploded side view of a step portion 1301 of an exemplary device, having an installation slope angle 1372 of approximately 35 degrees. Therefore, the treads' tilt angle 1365 (approximately 15 degrees) is shown to be greater than the tilt angle 1345 (approximately 5 degrees) of Fig. 13A. In this configuration, step outside corner 1354 is displaced away from step 1334, not providing an overhang. The higher tilt angle 1365 will promote a greater amount of water to drain through the orifice 1334.

[0108] Fig. 13C is an exploded side view of a step portion 1302 of an exemplary device, having an installation slope angle 1382 of approximately 15 degrees. Therefore, the treads' tilt

angle 1385 is shown to be greater than the tilt angle 1365 of Fig. 13B, and for this example is approximately 15 degrees.

[0109] It should be appreciated from the above Figs. that the installation slope can vary. However, it is believed the exemplary gutter guard can function very well between installation angles of approximately 20 – 53 degrees, wherein it is believed 35 degrees or thereabouts provides an ideal slope. Of course, depending on the steepness of the roof, amount of trees near gutters, approximate distance of trees to the gutters, the type of tree, high or low rainfall regions, height of gutter above the ground (for example, if the gutter is on the 2nd or 3rd story, there is less chance of debris issues falling on the gutter guard), and other factors, different “optimal” angles may be found.

[0110] Figs. 13A-C illustrate the relationship between the angles of the stair-step backward sloped ledges (e.g., treads) and the overall slope of the stair-steps, for a fixed tread-riser length ratio and fixed corner angle(s). Steeper sloped stair-step ledges improve water penetration into the gutter, because the tilted ledges act as barriers to inhibit rainwater flow from traveling past the ledge. Therefore, steeper sloped stair-step ledges help ensure higher volumes of rainwater will go down the orifices in the ledges. In many ways, they act as micro-troughs.

[0111] A compromise, however, is that the orifices are more exposed to debris (since there is less of an overhang protecting them). To address this, smaller holes can be devised. Or the outside corners can be positioned to overhang or be closer to the inside corners by appropriate adjustment of the respective A & B corner angles (Fig. 5) as well as the riser heights and/or the tread widths. That is, the apparent L-like shape of the stairs may be shifted to be more Z-like, for a different gutter installation slope angle, or vice versus. Thus, in light of the above, it

is understood that various modification and changes to the designs being shown are within the spirit and scope of this disclosure.

[0112] Figs. 14A-H are side view illustrations demonstrating various exemplary embodiments with differing step shapes, orientation, and sizes. For example, Fig. 14A shows an embodiment 1410 with steps 1412 with longer treads 1414 than for the treads 1418 of steps 1416. A slight shifting of the steps can be seen in the step pattern.

[0113] Fig. 14B shows an embodiment 1420 with steps 1422 with longer treads 1424 and risers 1425 than the treads 1428 and risers 1429 of steps 1426. The obvious result is steps 1422 protrude significantly more than steps 1426. As is apparent, water entering into steps 1422 is more likely to be impeded from flowing out of the steps 1422 than for steps 1426.

[0114] Fig. 14C shows an embodiment 1430 with increasing riser lengths (or equivalently, increasing tread lengths). This results in steps gradually changing shape and increasing in size with accompanying reduction in angles. For example, first step 1432 has a first angle 1433 with first tread 1434 and first riser 1435. Last step 1436 has a last angle 1347 with last tread 1438 and last riser 1439. The reduction between the first and last angles, as well as the increase in the riser lengths (and accompanying tread lengths to match) is self-evident.

[0115] Fig. 14D shows an embodiment 1440 that is the reverse of Fig. 14C, with decreasing riser lengths (or equivalently, increasing tread lengths). This results in steps gradually changing shape and decreasing in size and with accompanying increase in angles. For example, first step 1442 has a first angle 1433 and last step 1446 has a greater last angle 1447. The increase between the first and last angles, and attendant change in the step shape and size is self-evident.

[0116] Fig. 14E shows an embodiment 1450 with angle increases and reduction between the steps. First angle 1453 is smaller than angle 1455 which in turn is larger than angle 1457. The up-down change in the angles results in the shapes and orientations of the steps to change. Accordingly, step angles and attendant shapes, orientations, sizes may be varied according to design preference.

[0117] Fig. 14F shows an embodiment 1460 with constant angle steps 1466 with smaller tread/riser lengths than in the previous embodiments. This results in a high number of steps per unit length along the device.

[0118] Fig. 14G shows an embodiment 1470 with the uniform steps 1476 but with a singular enlarged step 1472. While this Fig. shows the enlarged step 1472 in the “middle” of the step progression, the enlarged step 1472 may be in any other part of the progression. Similarly, a converse embodiment can be envisioned, with a “smaller” step embedded among larger steps.

[0119] Fig. 14H shows an embodiment 1480 similar to the embodiment shown in Fig. 14F, but arched to fit a near zero installation angle. This configuration illustrates the ability of the exemplary device to “fit” undersized gutters (by arching the device) or gutters where the installation angle is substantially horizontal.

[0120] For designs where a single piece gutter guard is desired, it will be appreciated that there needs to be a balance between the rigidity of the guard to allow it to span the gutter, and having enough holes, perforations, and/orifices so that water will fall through the guard and into the gutter. The balancing act is that as one increases the number of holes and thus the cumulative hole area in the gutter guard, the guard will decrease in rigidity. The reduced rigidity means a supporting structure is often needed or the underlying guard material must be of a higher stiffness or weight which typically increases the costs. Further, the increase in overall hole area

will also increase the likelihood that debris can get caught as the debris engages the guard. Therefore, a design that provides a large enough hole area without sacrificing rigidity would be significant.

[0121] In view of the above, a design using an exemplary stair-stepped embodiment spanning a 5 inch wide gutter was tested having about 120 holes per 1 foot long section. Each hole had a diameter of about 0.18 inches to result in a cumulative hole area of 3.224 square inches per foot long section of the exemplary device. By way of comparison, a conventional one-piece gutter guard, which is commonly available as Smart Screen and has about 288 holes per foot length, and has a total hole area of about 5.29 square inches. It should be noted here that increased hole count does not necessary translate to increased water penetration. In fact, it may be the opposite. For example, the increase in hole count is usually obtained by reducing the hole size, which results in reducing the ability for the water to penetrate the gutter guard.

[0122] Another conventional one-piece gutter guard commonly available as Leaftek, has a hole count of 320 per foot length and a total hole area of about 5.8 square inches. Amerimax Titan (an Ominmax company) is another conventional one-piece gutter guard, having a 432 hole count per foot length, and a hole area of about 7.6 square inches. The Leaftek and Amerimax Titan have both larger hole count and larger hole area. The former factor was discussed above, the latter factor is that with excessively large hole areas, the more likely debris will enter into the hole. Therefore, an engineering tradeoff is necessary, wherein hole size, area, and ability to capture water while minimizing debris entrance is sought.

[0123] An exemplary design with a lower hole area per foot length was tested and a performance comparison of the above exemplary design and the above conventional gutter guards revealed that the exemplary design performed significantly better with respect to water

capture while having less hole area (meaning less debris is likely to enter the gutter). Thus, the exemplary design can be intrinsically stiffer, whereby thinner, less expensive materials can be used for a given span, or longer spans can be covered, while retaining superior performance over conventional gutter guards.

[0124] Because of the protection from the step overhang, less holes, but larger diameter holes can be used. In one exemplary embodiment, the diameter of the holes was about 21% larger than the prior art's but had an increase in water flow by over 400%.

[0125] Fig. 15 is an illustration of an alternative trough portion of an exemplary single piece gutter guard device 1500. Device 1500 has very similar characteristics to the devices described above. However, an optional roof attachment portion 1510 design with a bendable face is shown. A bent section 1515 terminates roof attachment portion 1510. This configuration of the roof attachment portion 1510 enables attachment to a vertical roof or building section, if so needed. Multiple bends may be devised, according to the installation needs. Gutter lip attachment portion 1590 is also configured with an optional downward (or angled) flap 1597 at its terminal end. This flap 1597 helps to align the gutter lip attachment portion 1590 to the gutter lip (not shown) as well as cause overflowing water to exit further from gutter lip.

[0126] Also, the trough portion 1560 is configured with one or more barricades 1568. The barricade(s) 1568 can be formed directly in the trough portion 1560 during manufacturing of the trough portion 1560, or can be added later. For example, the barricade 1568 can be "impressed" into the material of the trough portion 1560 or as a separate material or structure affixed to the trough portion 1560. The barricade 1568 can be located on the top surface 1569 or bottom surface 1570 of the trough portion 1560. As shown in this example, the at least one barricade 1568 is disposed on the top surface 1569 of trough 1560. The topside placement

means the barricade 1568 will protrude upward and will aide in preventing debris from remaining on the device 1500. For example, debris can often be wet and when wet will not readily move off the device 1500, especially if resting on a flat surface. However, by having a barricade 1568, it provides an elevated resting surface for debris with open areas lateral to the barricade 1568 and below the debris. The open areas will cause the debris dry out quicker. Being drier, wind and the like will more easily blow the debris off the device.

[0127] Fig. 16 is a side view illustration of the gutter guard device 1500. Here, step orifices 1534 can be seen, as well as trough orifices 1562. Barricade(s) 1568 can be an elevated section of the trough 1560 or may be an added material 1561. It should be appreciated that the profile and shape of the barricade(s) 1568 can be different than shown. For example, one barricade of the barricades 1568 may have a different shape as well as a different height than a neighboring or other barricade. Thus, variations to the barricade styles, sizes, shapes, profiles, etc. are understood to be within the scope of this disclosure.

[0128] Fig. 17 is another exemplary gutter guard device 1700, with several variations. For example, a non-planar roof attachment portion, very large tread-to-riser ratio, multiple orifices in the treads, side port(s) or orifices in the step(s) and walls of the trough. Further, barricade(s) 1768 is recessed in the trough 1760. Focusing first on the barricade aspect, the recessed barricade(s) 1768 can act as a micro-trough, helping to drain water faster through its barricade orifice(s) 1769. More than one orifice 1769 may be utilized in the barricade(s) 1768. Additionally, as stated above, the barricade(s) 1768 can have different shapes or sizes, etc. For example, the barricade(s) 1768 may have a sloping bottom to help direct water to a respective orifice. Several such barricades may be utilized. Similar to the reasoning stated above, the

recessed barricade 1768 is beneficial for rapidly removing debris from the trough 1760, as debris will likely span the barricade's width and therefore air can dry the underside of the debris.

[0129] With respect to the large tread-to-riser ratio, this will reduce the number of steps in the step portion 1730. Conversely, a design may be contemplated using a large riser-to-tread ratio, which will produce an increased number of steps in the step portion 1730. Further, different sized steps may be devised. Accordingly, different sized steps, and different riser-to-tread or vice versus ratios can be implemented without departing from the spirit and scope of this disclosure. With respect to the roof attachment portion 1710, it is shown here with an optional downward bent section 1715, enabling attachment to a building wall or roof support, etc. Also, the step portion 1730 contains more than one row or pattern of step orifices 1734 in the respective treads 1740, which may be of similar or different sizes. Further, trough portion 1760 sides are shown with optional orifices 1737 and 1761. Orifice(s) 1761 is on a vertical wall and helps to drain water that is filling the trough portion, acting as a second (or primary) relief for onrushing water. Orifice(s) 1737 is similar but disposed on an opposite wall, in the last step's riser 1750. This orifice 1737 operates like a tread orifice but is on the riser. Finally, gutter lip attachment portion 1790 is relatively flat, not having the optional flap shown in Fig. 15. It is understood that the various modifications or features shown in this Fig. are demonstrative of possible modifications to one or more of the various embodiments described in this disclosure and are not to be limited to the features shown in Fig. 17.

[0130] Fig. 18 is a side view illustration of an exemplary gutter guard device 1800, showing a possible step size variation and a combination of a raised barricade 1867 and a recessed barricade 568, with corresponding barricade orifice(s) 1869. As alluded above, the step size can be altered within an exemplary device. Here, first step 1835 is larger than the following

steps. Of course, depending on design preference, the size difference may be implemented at another location or locations within the step portion 1830. First step 1835 may also have a different sized (or shape) orifice 1832 than the orifices 1834 of the other steps.

[0131] With respect to the barricades, they can be reversed in position from what is shown, having the raised barricade 1867 to the right of the recessed barricade 1868. Or, more than one raised, or recessed barricade may be utilized. Of note is the curved profiles of the barricades, which may differ from what is shown and may be dissimilar between barricades, in profile, shape, height, etc. Trough orifice 1862 is shown bordering gutter lip attachment portion 1890. Optional second trough orifice(s) 1866 may be disposed forward to raised barricade 1867, as the barricade 1867 naturally creates a “well” area between the barricade 1867 and the riser of the last step of step portion 1830. The combination of raised and recessed barricades is understood to provide superior drying and debris removal features than a single type barricade.

[0132] Of additional note is that roof attachment portion 1810 may have orifices 1834, provided the orifices 1834 are over a gutter opening (not shown). In contrast to Fig. 17's embodiment, this embodiment shows a configuration where the roof attachment portion 1810 is flat and step orifices 1834 are formed as a single row within the step portion 1830. Of course, these features may be altered as desired.

[0133] As the above Figs. illustrate a handful of barricade forms, it is understood that other barricade forms may be used, according to design preference. For example, Fig. 19 shows a cluster 1968 of six circular barricade shapes that may be used in an exemplary device's trough. The clusters 1968 can be more or less than six objects. The objects within the cluster 1968 can be very small in diameter or large enough so the cluster fills the respective trough. The objects can be recessed (with respective orifices), raised, of any shape including oval, regular or irregular

quadrilaterals, regular or irregular polygons, concave or convex contours or a mix of several shapes.

[0134] Fig. 20 shows another barricade form formed of “arrow heads” 2068 with angled sides. As stated above, the barricade(s) can be raised or recessed, or combinations of the two. Fig. 21 shows one or more crescent shapes 2168, which can be positioned at any angle, as well as be raised or recessed, or a combination thereof. Fig. 22 shows a single disc 2269 as a barricade. Fig. 23 shows a starburst 2368 as a barricade. As is evident from the above Figs., the barricade may be of any desired shape size, arrangement, or orientation, etc. For example, the barricade can be a letter, number, symbols. With such options, the barricade may even spell out a name, such as the product’s manufacturer.

[0135] While this invention has been described in conjunction with the specific embodiments outlined above, it is evident that many alternatives, modifications and variations will be apparent to those skilled in the art. Accordingly, the preferred embodiments of the invention, as set forth above, are intended to be illustrative, not limiting. Various changes and combinations thereof may be made without departing from the spirit and scope of this invention. It should be apparent that various different modifications can be made to the exemplary embodiments described herein without departing from the scope and spirit of this invention disclosure. When structures are identified as a means to perform a function, the identification is intended to include all structures, which can perform the function specified.

CLAIMS

What is claimed is:

1. A single piece, self-supporting gutter guard comprising:

a roof attachment portion configured for attachment to a roof or building or roof-side end of a prospective gutter;

a step portion, integrally connected to the roof attachment portion, composed of a plurality of connected steps with corresponding treads and risers, wherein at least one of the connected steps has at least one row of step orifices disposed in its tread;

a trough portion integrally connected to a last step of the step portion, having at least one row of trough orifices disposed therein, wherein a floor of the trough portion is at a lower elevation than a tread of the last step; and

a gutter lip attachment portion integrally connected to the trough portion, configured for attachment to a lip of the prospective gutter, wherein the floor of the trough portion is below a top of the gutter lip attachment portion, and wherein the trough and the gutter lip attachment portion share a common wall;

wherein the step portion is self-supporting, provides an uneven surface for easier debris drying and removal, and is oriented at a downward angle from the roof attachment portion to the trough portion.

2. The gutter guard of claim 1, wherein the roof attachment portion includes a terminal section that is at an angle from a plane of the roof attachment portion.

3. The gutter guard of claim 1, further comprising riser orifices disposed in the at least one of the connected steps.

4. The gutter guard of claim 1, wherein the step orifices are partially disposed in the tread and partially disposed in a riser of an adjacent step.
5. The gutter guard of claim 1, wherein the step orifices are at least one of non-circular in shape, arranged in a plurality of rows, arranged in a plurality of offset rows, and proximal to a riser of an adjacent step that is on a roof attachment portion side of an orificed tread.
6. The gutter guard of claim 1, wherein the trough orifices are at least one of non-circular in shape, arranged in a plurality of rows, arranged in a plurality of offset rows, proximal to a riser of an adjacent step that is on a roof attachment portion side of the orifices, proximal to the common wall, disposed in the common wall, and disposed at a junction between the trough's floor and the common wall.
7. The gutter guard of claim 1, wherein all of the steps in the step portion have orifices.
8. The gutter guard of claim 1, wherein the trough portion is wider than at least a width of a step in the step portion.
9. The gutter guard of claim 1, wherein an outside corner of the at least one of the connected steps partially overhangs an orifice in a lower adjacent step's tread.
10. The gutter guard of claim 1, wherein an outside corner of the at least one of the connected steps completely overhangs an orifice in a lower adjacent step's tread.
11. The gutter guard of claim 1, wherein an angle of an outside corner and inside corner of the at least one of the connected steps is less than 90 degrees.
12. The gutter guard of claim 1, wherein the step portion's downward angle is between 15 — 45 degrees.
13. The gutter guard of claim 1, wherein a tread length of the treads is greater than a riser length of the risers.

14. The gutter guard of claim 1, wherein one or more steps of the at least one of the connected steps is at least one of a different size and different shape than one or more other steps of the at least one of the connected steps.
15. The gutter guard of claim 1, wherein one or more steps of the at least one of the connected steps has at least one of a different inside corner and outside corner angle than one or more other steps of the at least one of the connected steps.
16. The gutter guard of claim 1, wherein the last step is at least one of larger, different in shape and different in angle than a first step of the step portion.
17. The gutter guard of claim 1, further comprising a barrier in the trough portion.
18. The gutter guard of claim 17, wherein the barrier is at least one of raised and recessed.
19. The gutter guard of claim 18, wherein the recessed barrier has an orifice in a bottom thereof.
20. The gutter guard of claim 17, wherein barrier is formed from the floor of the trough portion.
21. The gutter guard of claim 1, wherein the barrier is shaped as at least one of a circle, plurality of circles, rectangle, arrow head, arc, and starburst.
22. The gutter guard of claim 1, wherein the orifices are perforations in a material of the step portion and trough portion.
23. The gutter guard of claim 1, wherein the plurality of connected steps are at least 3 or more steps.
24. The gutter guard of claim 1, wherein the gutter lip attachment portion further comprises a terminal end extending past the lip of the prospective gutter, and being downwardly oriented.
25. A self-supporting gutter guard comprising:
 - a roof attachment portion;

a step portion connected to the roof attachment portion, composed of a plurality of connected steps with corresponding treads and risers, wherein at least one of the connected steps has at least one row of step orifices disposed in its tread; and

a gutter lip attachment portion connected to the step portion.

26. A self-supporting gutter guard formed from a single piece of material, comprising:

a roof attachment portion;

a step portion connected to the roof attachment portion, composed of a plurality of connected steps with corresponding treads and risers, wherein at least one of the connected steps has at least one row of step orifices disposed in its tread; and

a gutter lip attachment portion connected to the step portion.

AMENDED CLAIMS

received by the International Bureau on 25 November 2020 (25.11.2020)

CLAIMS

What is claimed is:

1. A single piece, self-supporting gutter guard comprising:

a roof attachment portion configured for attachment to a roof or building or roof-side end of a prospective gutter;

a stepped portion, integrally connected to the roof attachment portion, composed of a plurality of connected steps formed from a step tread joined to a step riser with joint angles of less than 90 degrees, wherein at least one of the connected steps has at least one row of step orifices disposed in its tread;

a trough portion integrally connected to a riser of a last step of the stepped portion, having at least one row of trough orifices disposed therein, wherein a floor of the trough portion is at a lower elevation than a tread of the last step; and

a gutter lip attachment portion integrally connected to the trough portion, configured for attachment to a lip of the prospective gutter, wherein the floor of the trough portion is below a top of the gutter lip attachment portion, and wherein the trough and the gutter lip attachment portion share a common wall;

wherein the stepped portion is self-supporting, provides an uneven surface for easier debris drying and removal, and is oriented at a downward angle from the roof attachment portion to the trough portion.

2. The gutter guard of claim 1, wherein the roof attachment portion includes a terminal section that is at an angle from a plane of the roof attachment portion.

3. The gutter guard of claim 1, further comprising riser orifices disposed in the at least one of the connected steps.
4. The gutter guard of claim 1, wherein the step orifices are partially disposed in the tread and partially disposed in a riser of an adjacent step.
5. The gutter guard of claim 1, wherein the step orifices are at least one of non-circular in shape, arranged in a plurality of rows, arranged in a plurality of offset rows, and proximal to a riser of an adjacent step that is on a roof attachment portion side of an orificed tread.
6. The gutter guard of claim 1, wherein the trough orifices are at least one of non-circular in shape, arranged in a plurality of rows, arranged in a plurality of offset rows, proximal to a riser of an adjacent step that is on a roof attachment portion side of the orifices, proximal to the common wall, disposed in the common wall, and disposed at a junction between the trough's floor and the common wall.
7. The gutter guard of claim 1, wherein all of the steps in the stepped portion have orifices.
8. The gutter guard of claim 1, wherein the trough portion is wider than at least a width of a step in the stepped portion.
9. The gutter guard of claim 1, wherein an outside corner of the at least one of the connected steps partially overhangs an orifice in a lower adjacent step's tread.
10. The gutter guard of claim 1, wherein an outside corner of the at least one of the connected steps completely overhangs an orifice in a lower adjacent step's tread.
11. The gutter guard of claim 1, wherein an angle of an outside corner and inside corner of the at least one of the connected steps is less than 90 degrees.

12. The gutter guard of claim 1, wherein the stepped portion's downward angle is between 15 – 45 degrees.
13. The gutter guard of claim 1, wherein a tread length of the treads is greater than a riser length of the risers.
14. The gutter guard of claim 1, wherein one or more steps of the at least one of the connected steps is at least one of a different size and different shape than one or more other steps of the at least one of the connected steps.
15. The gutter guard of claim 1, wherein one or more steps of the at least one of the connected steps has at least one of a different inside corner and outside corner angle than one or more other steps of the at least one of the connected steps.
16. The gutter guard of claim 1, wherein the last step is at least one of larger, different in shape and different in angle than a first step of the stepped portion.
17. The gutter guard of claim 1, further comprising a barrier in the trough portion.
18. The gutter guard of claim 17, wherein the barrier is at least one of raised and recessed.
19. The gutter guard of claim 18, wherein the recessed barrier has an orifice in a bottom thereof.
20. The gutter guard of claim 17, wherein barrier is formed from the floor of the trough portion.
21. The gutter guard of claim 1, wherein the barrier is shaped as at least one of a circle, plurality of circles, rectangle, arrow head, arc, and starburst.
22. The gutter guard of claim 1, wherein the orifices are perforations in a material of the stepped portion and trough portion.

23. The gutter guard of claim 1, wherein the plurality of connected steps are at least 3 or more steps.

24. The gutter guard of claim 1, wherein the gutter lip attachment portion further comprises a terminal end extending past the lip of the prospective gutter, and being downwardly oriented.

25. A self-supporting gutter guard comprising:

a roof attachment portion;

a stepped portion connected to the roof attachment portion, composed of a plurality of connected steps formed from a step tread joined to a step riser with joint angles of less than 90 degrees, wherein at least one of the connected steps has at least one row of step orifices disposed in its tread; and

a gutter lip attachment portion connected to the stepped portion.

26. A self-supporting gutter guard formed from a single piece of material, comprising:

a roof attachment portion;

a stepped portion connected to the roof attachment portion, composed of a plurality of connected steps formed from a step tread joined to a step riser with joint angles of less than 90 degrees, wherein at least one of the connected steps has at least one row of step orifices disposed in its tread; and

a gutter lip attachment portion connected to the stepped portion.

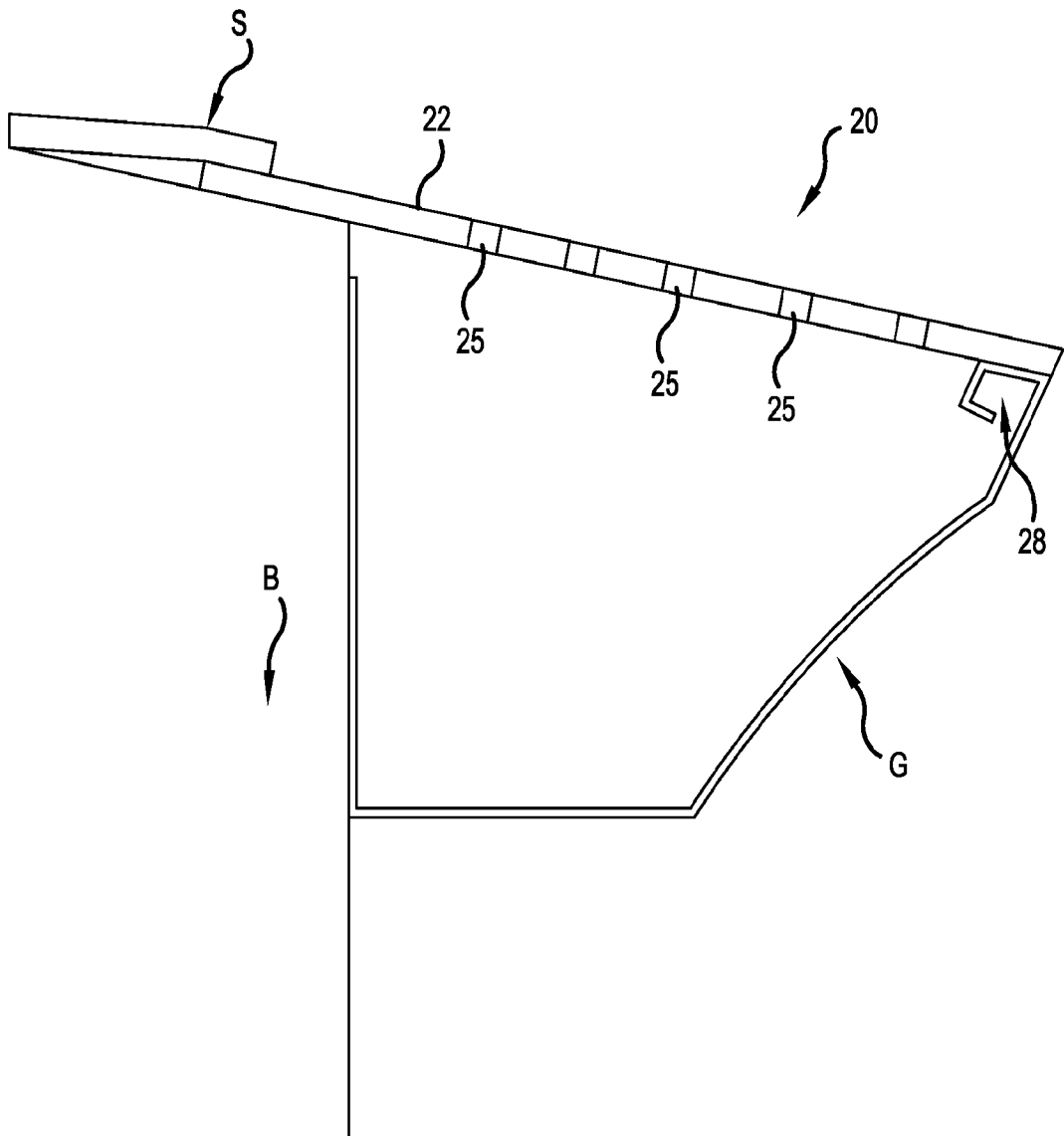

FIG.1
PRIOR ART

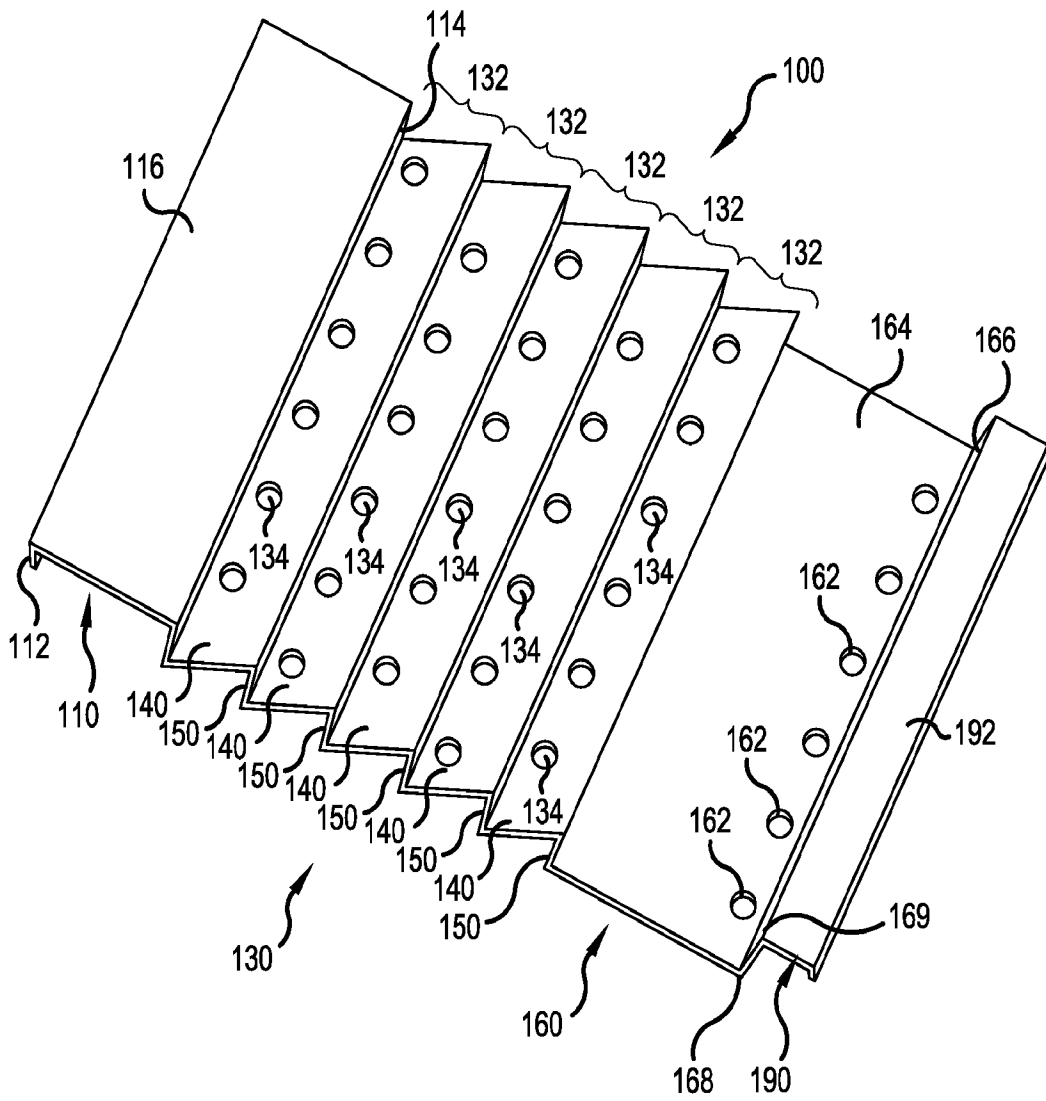

FIG.2

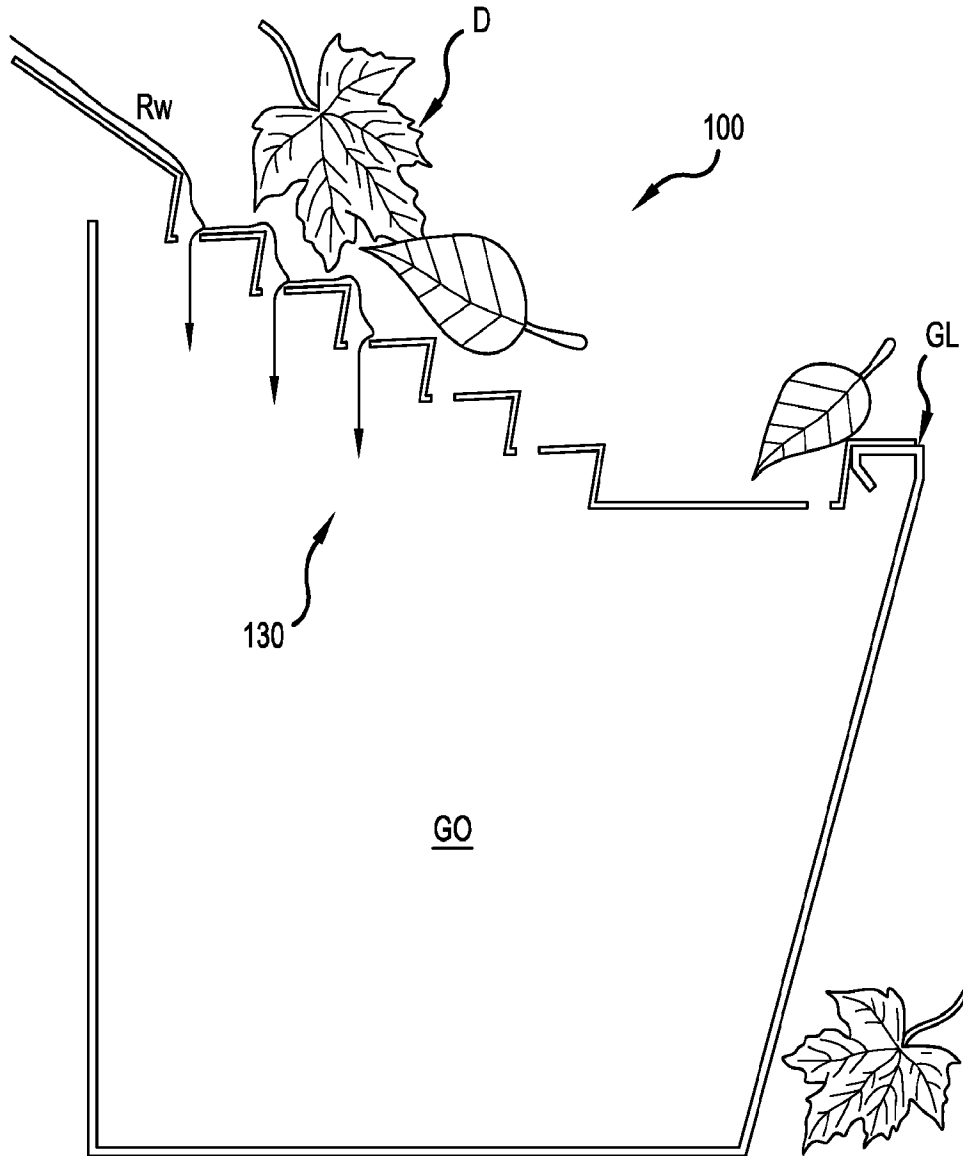

FIG.4

5/31

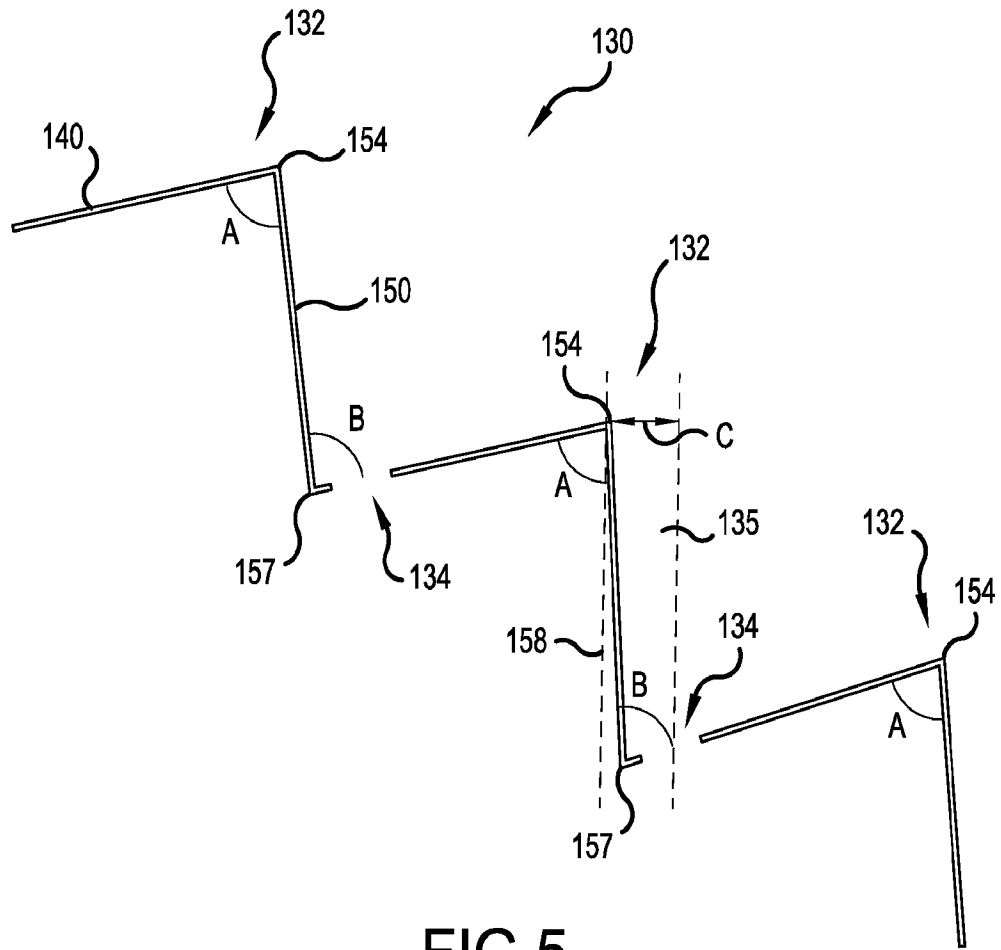

FIG. 5

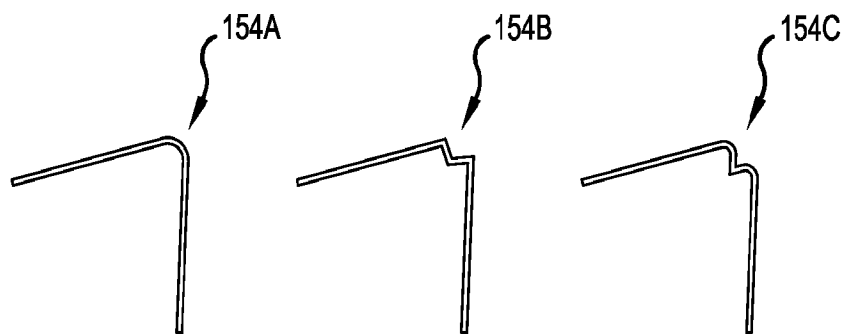

FIG. 6

6/31

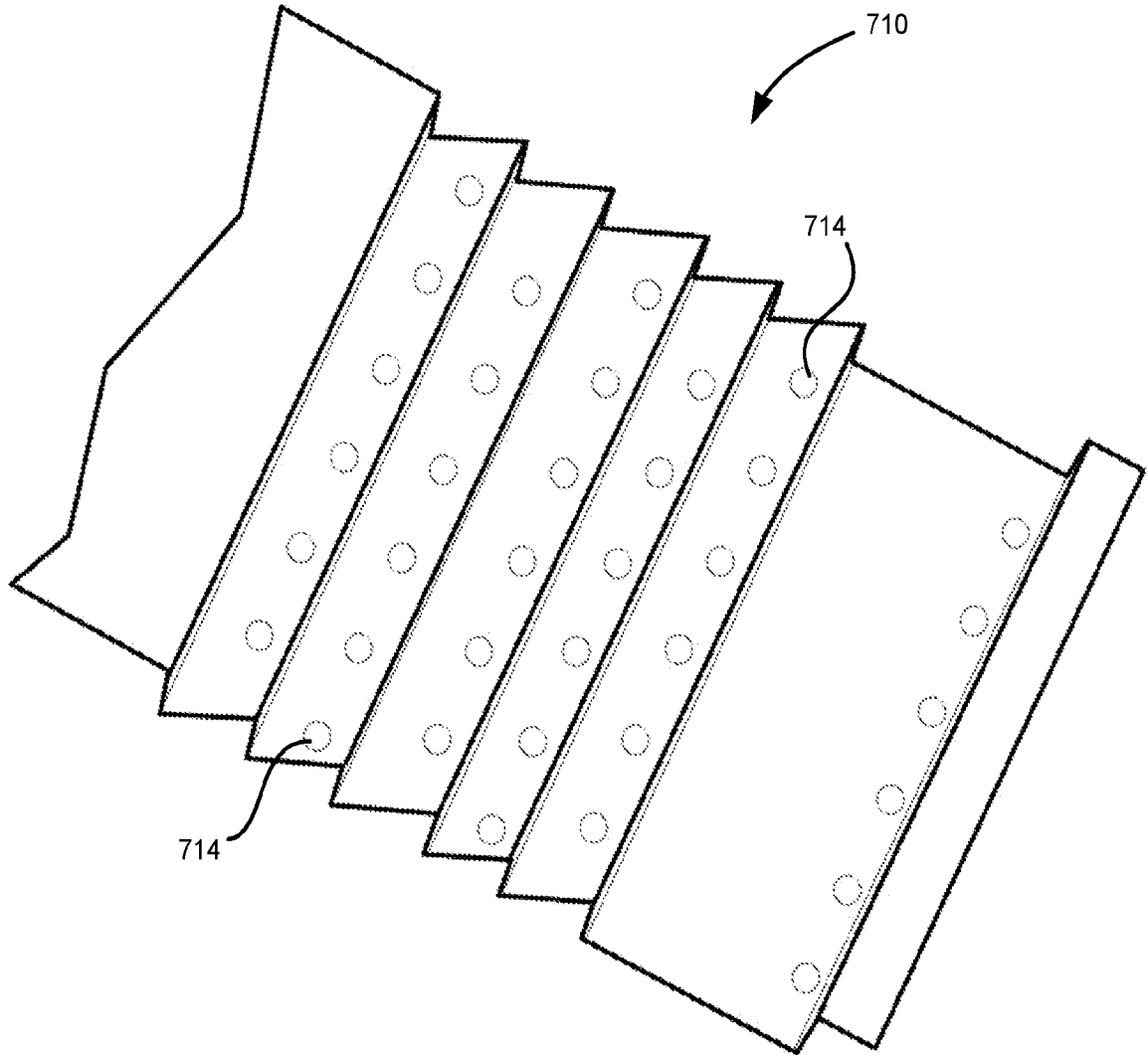

FIG.7A

7/31

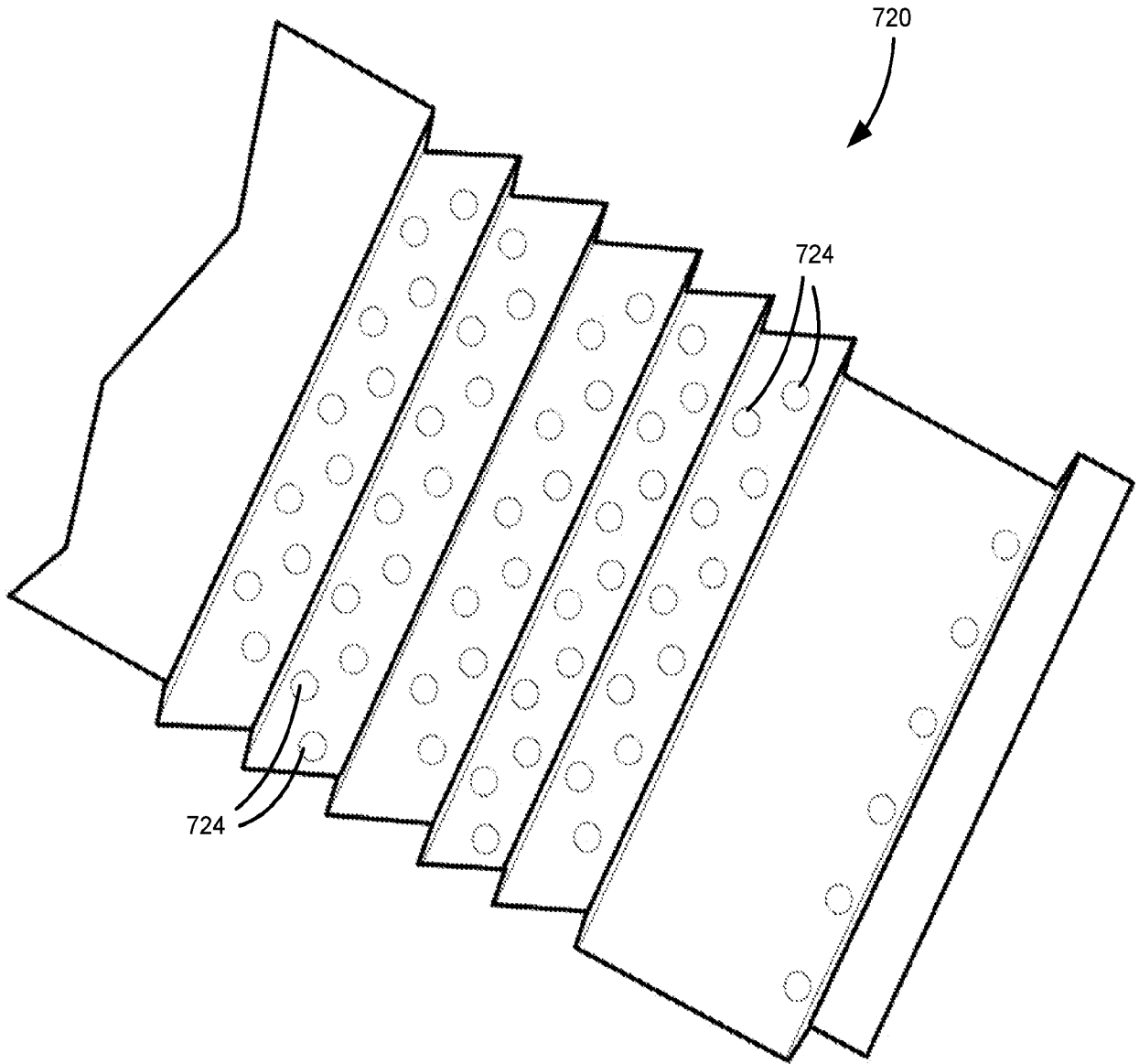

FIG.7B

8/31

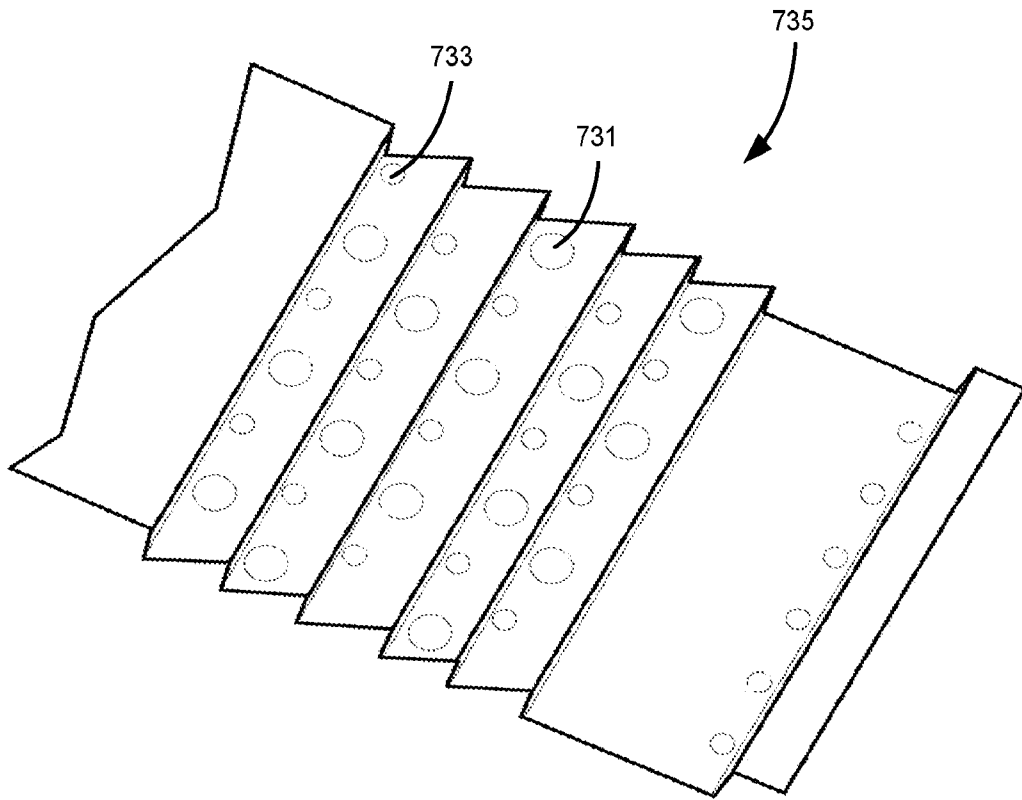

FIG. 7C

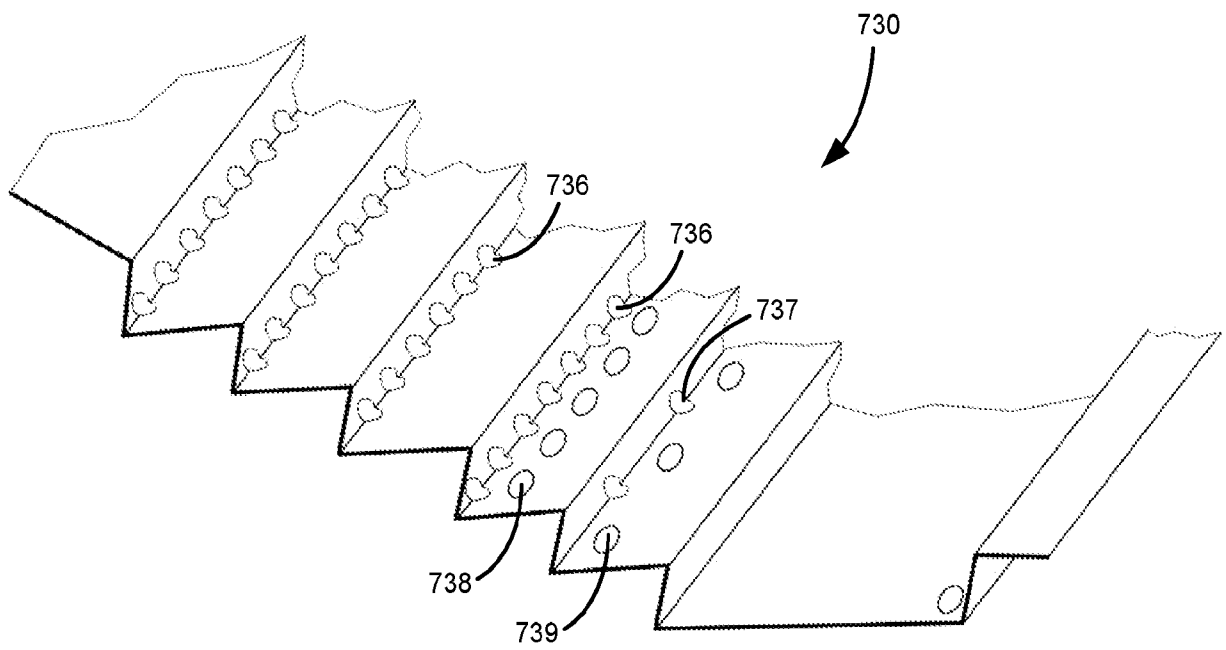

FIG. 7D

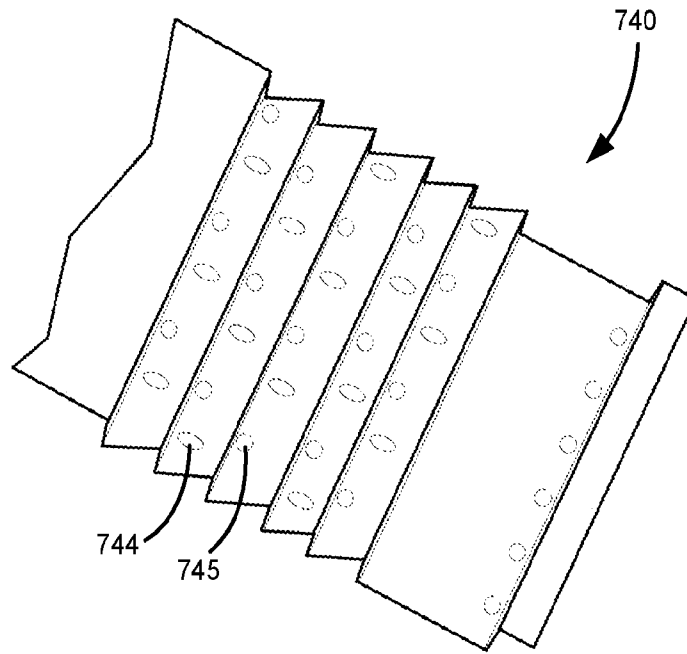

FIG. 7E

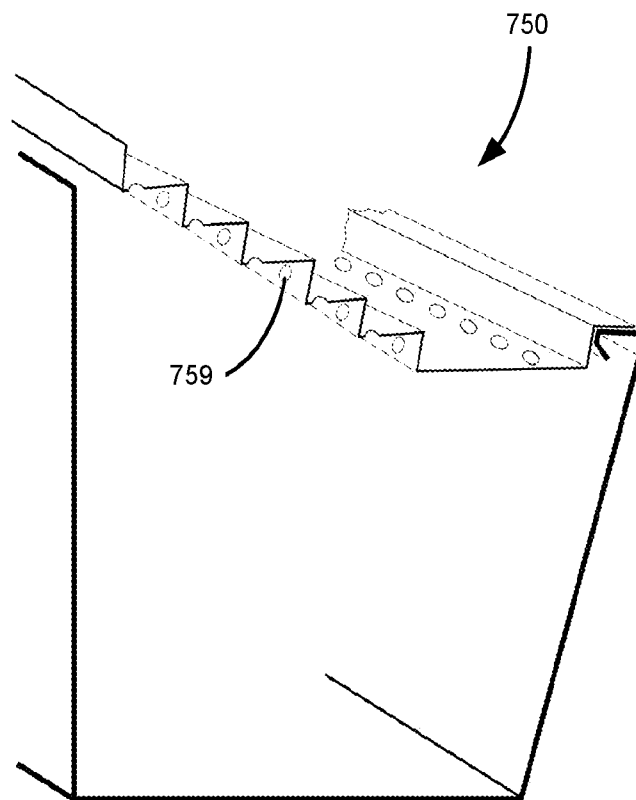

FIG. 7F

10/31

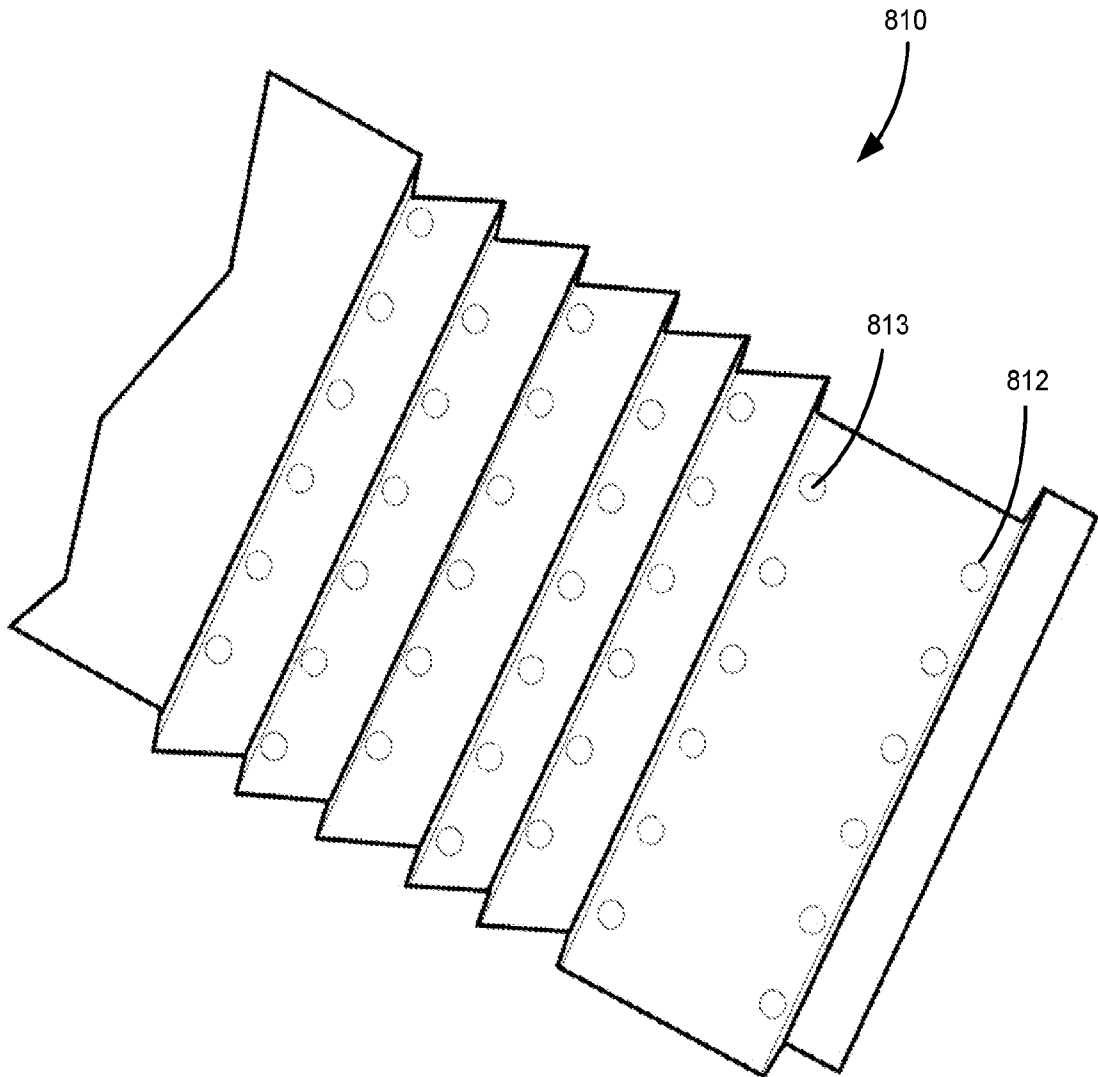

FIG.8A

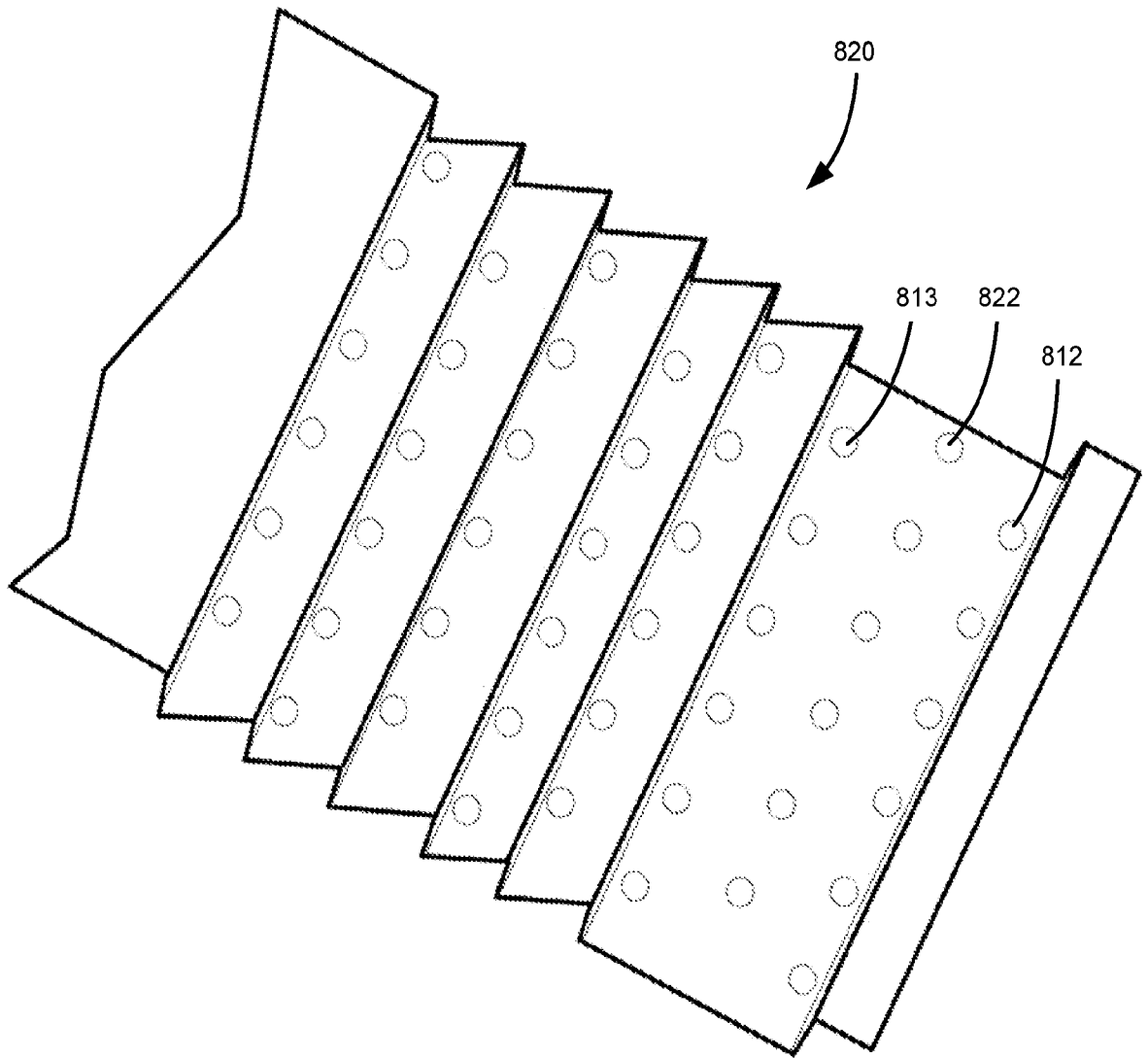

FIG.8B

12/31

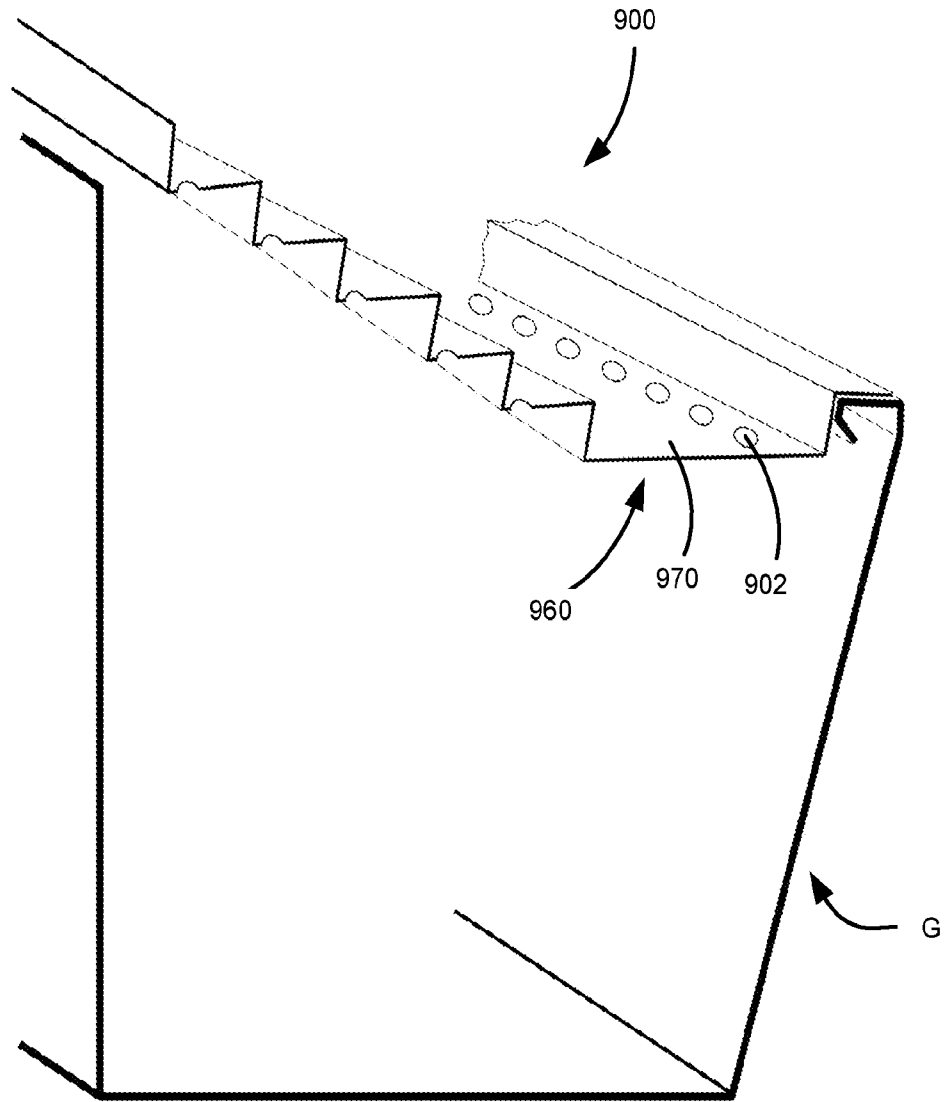

FIG.9A

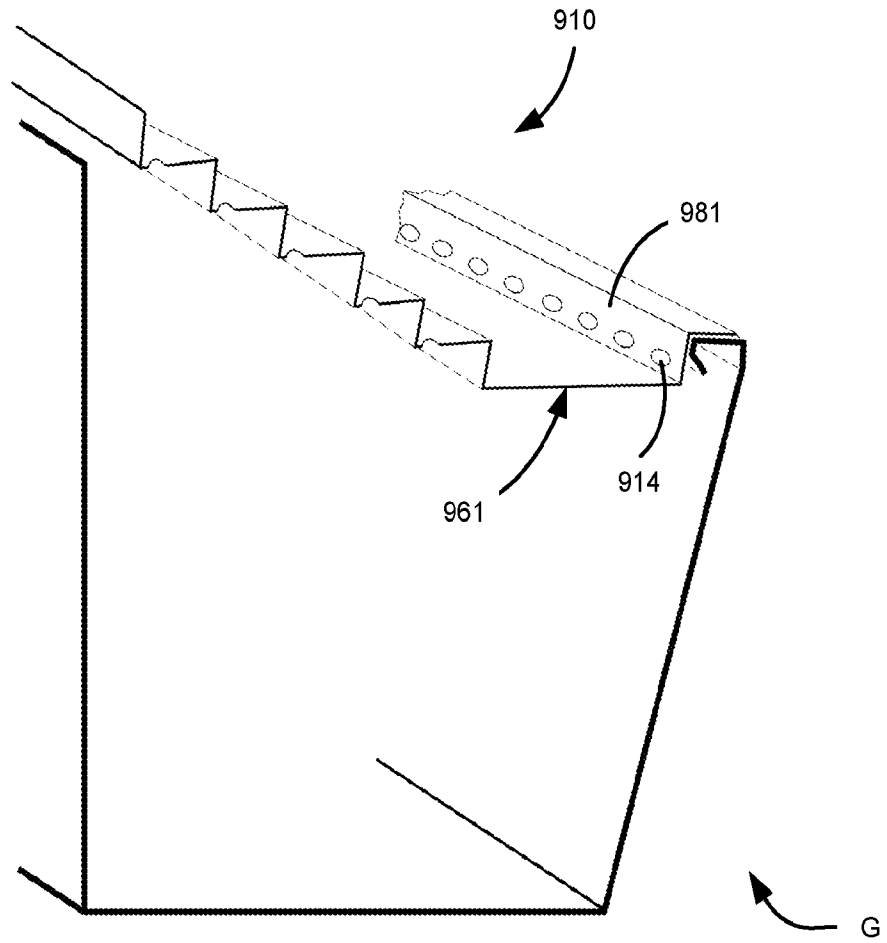

FIG.9B

14/31

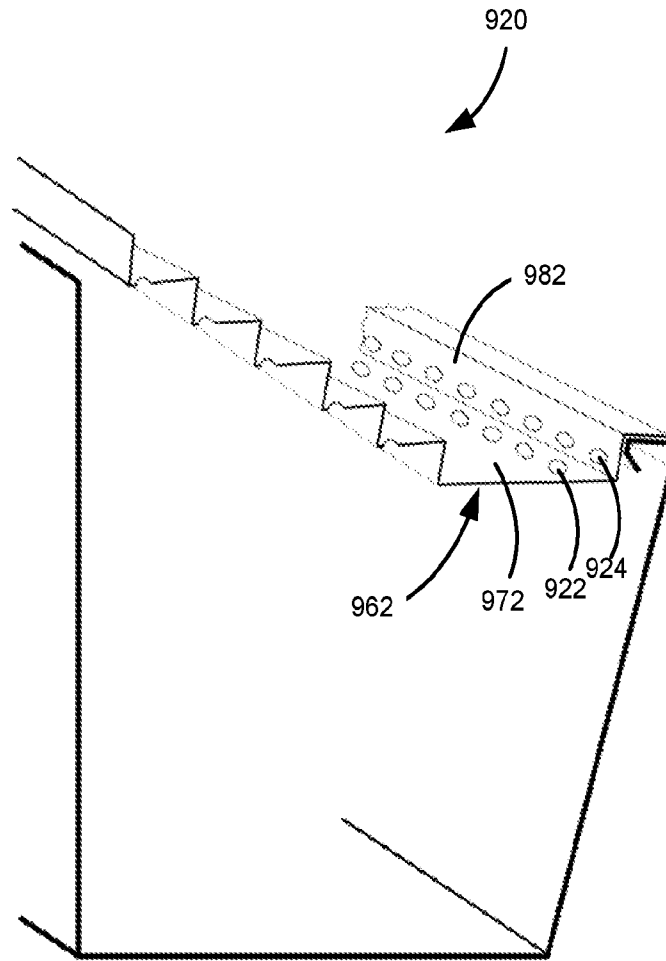

FIG.9C

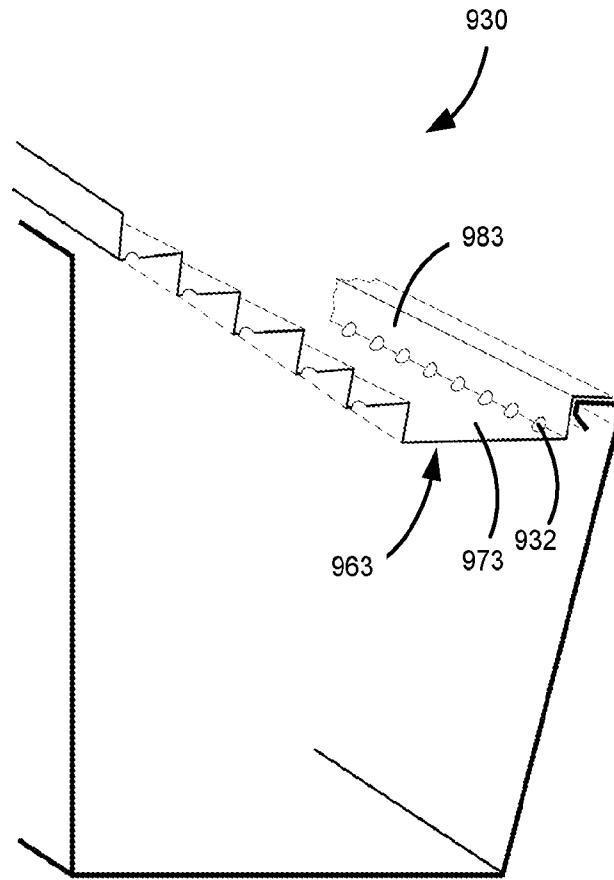

FIG.9D

16/31

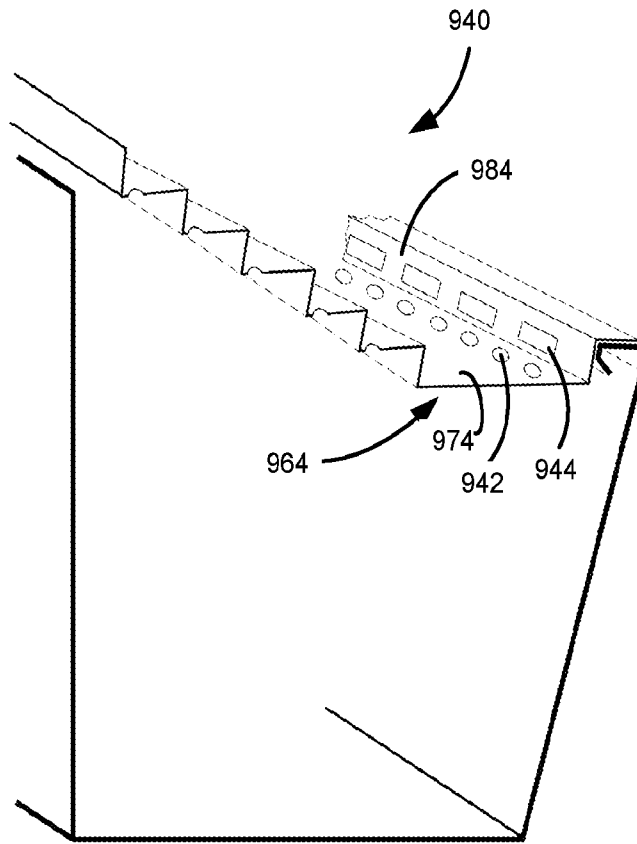

FIG.9E

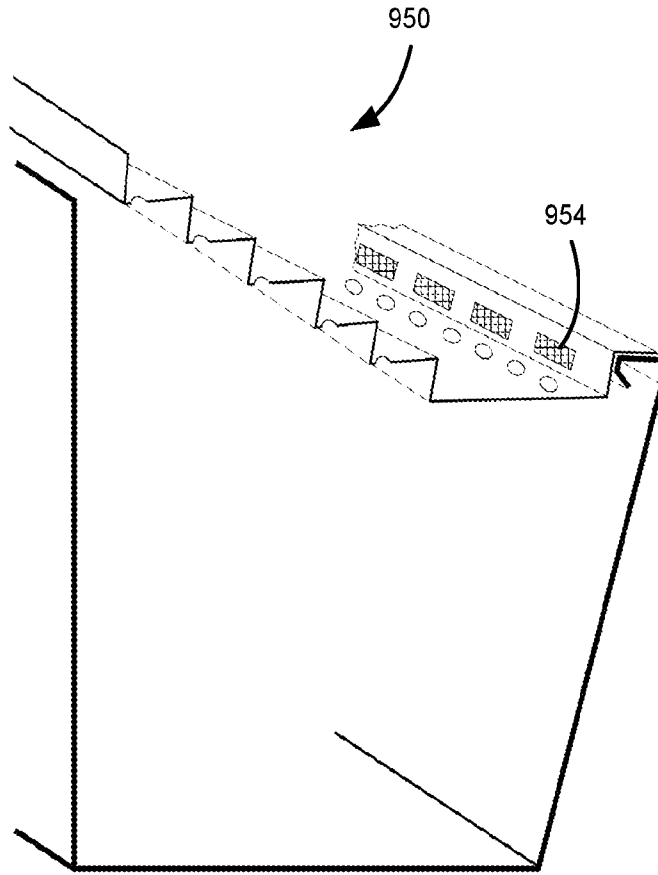

FIG.9F

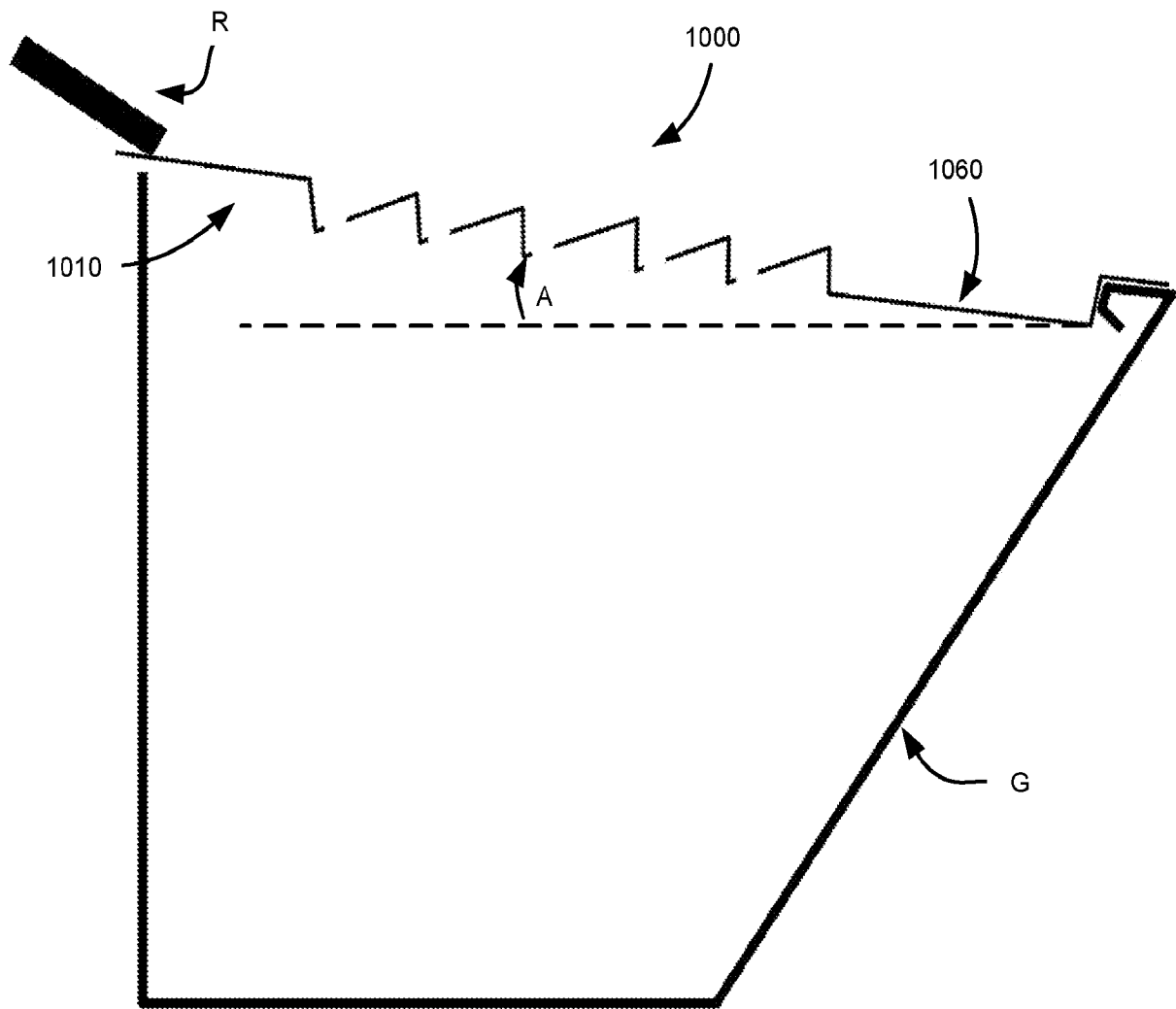

FIG. 10

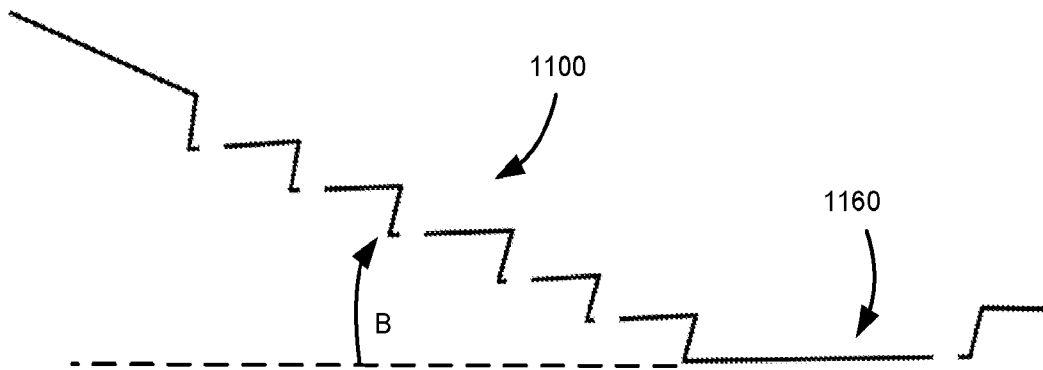

FIG. 11

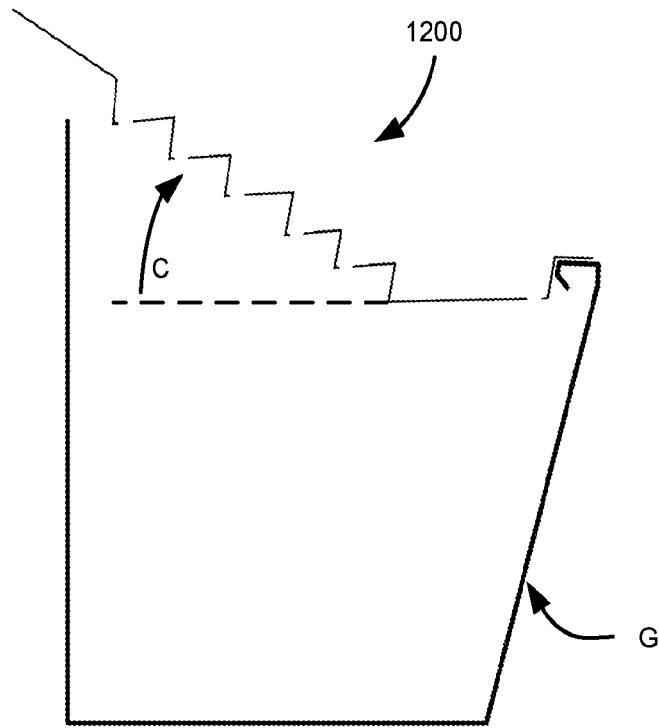

FIG.12

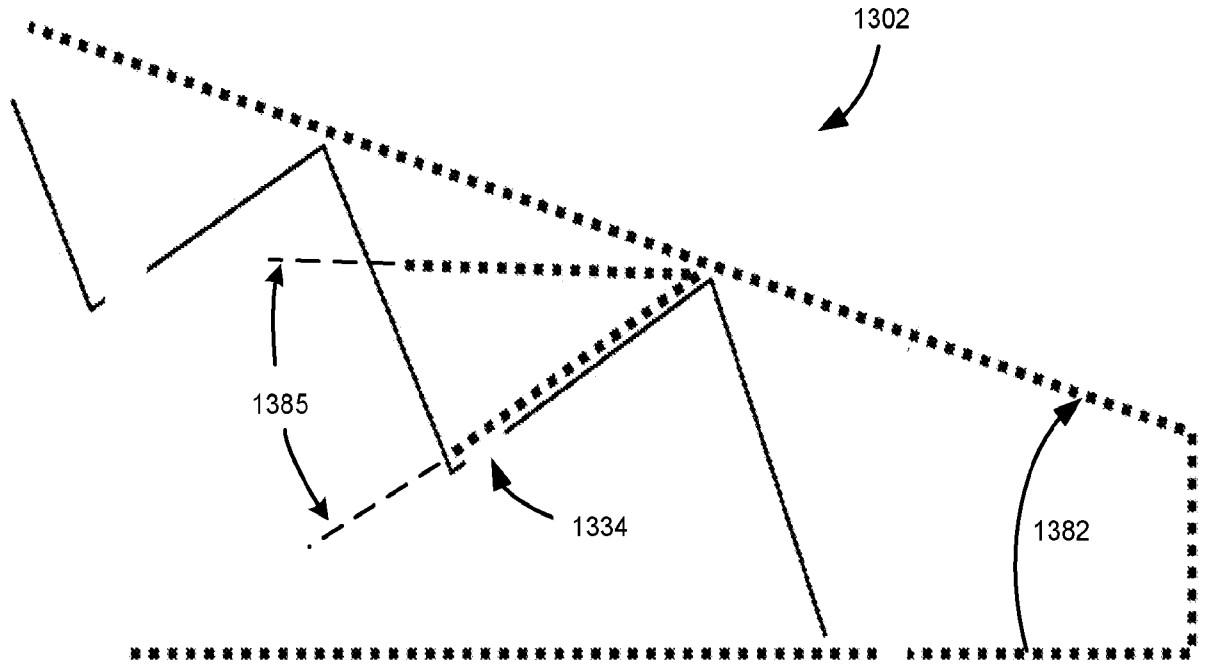
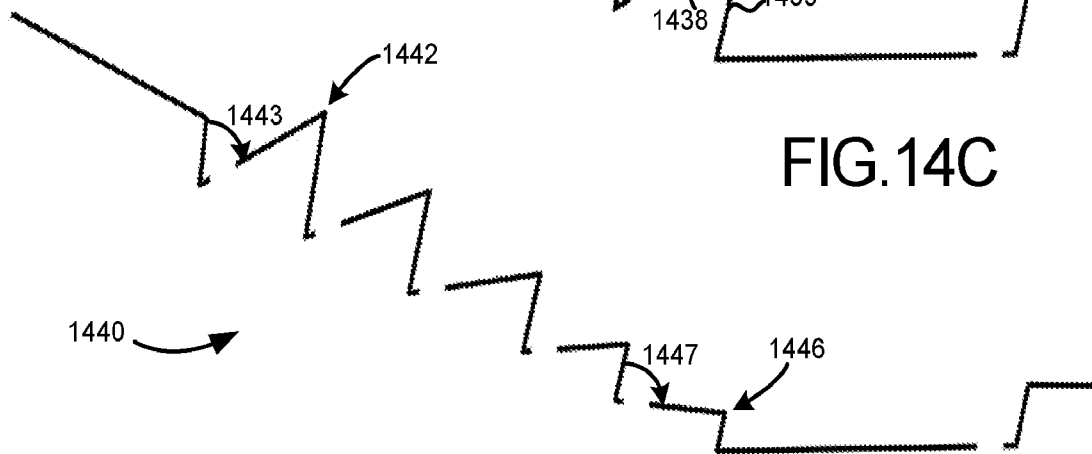
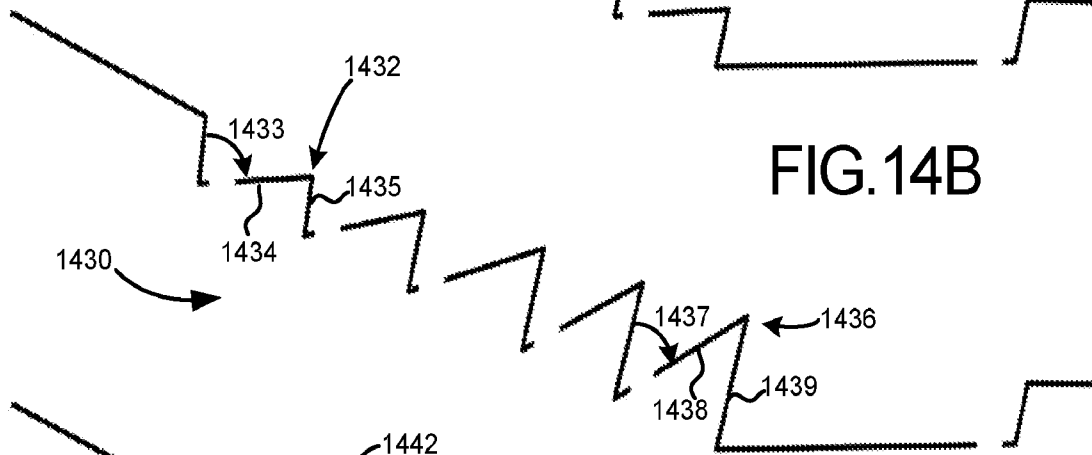
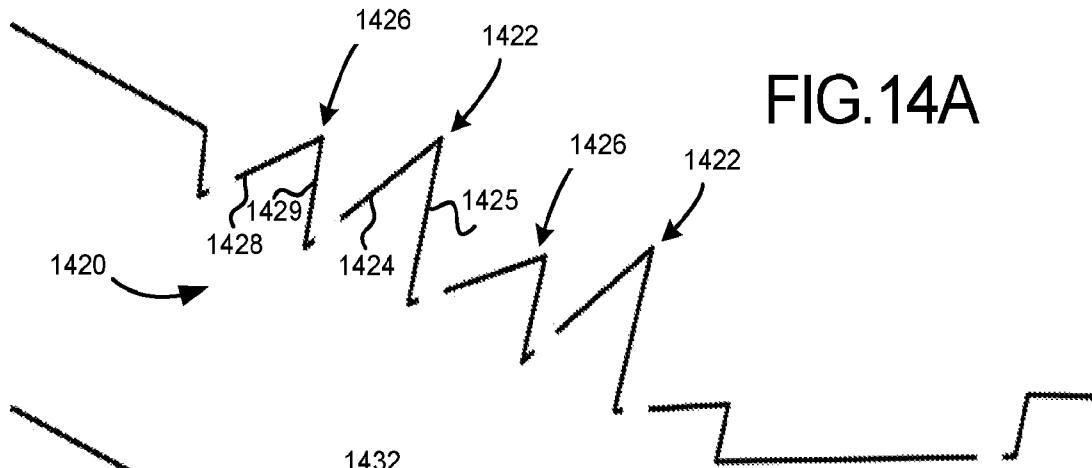
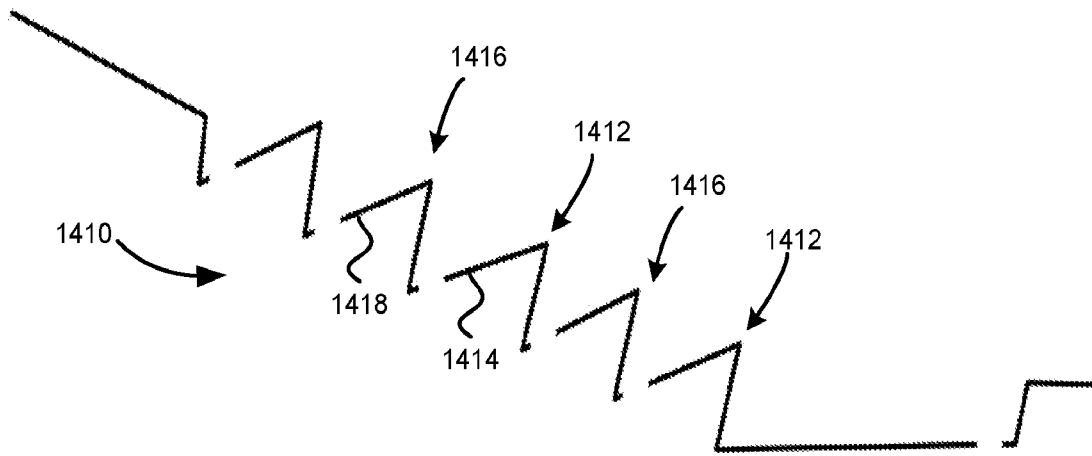

FIG.13C



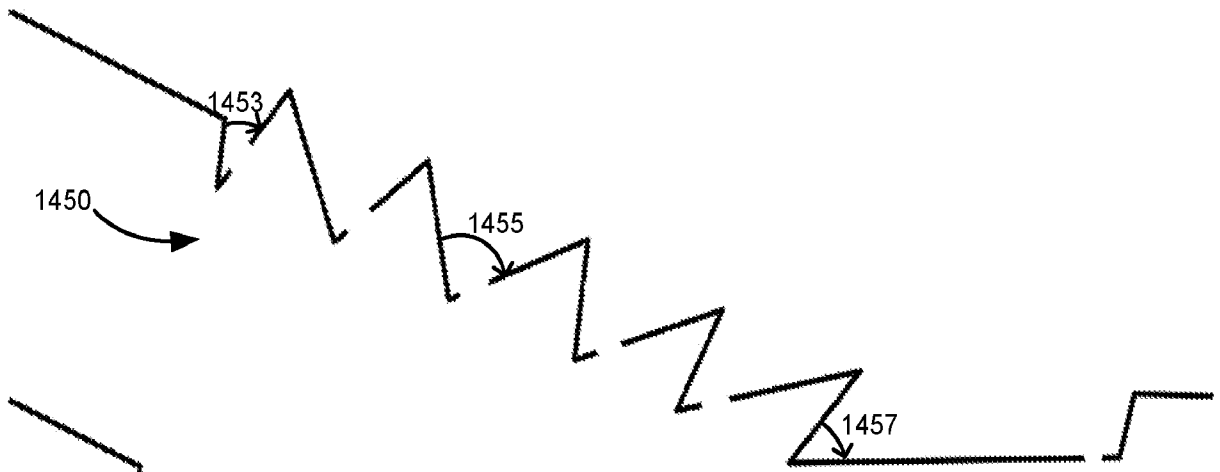

FIG. 14E

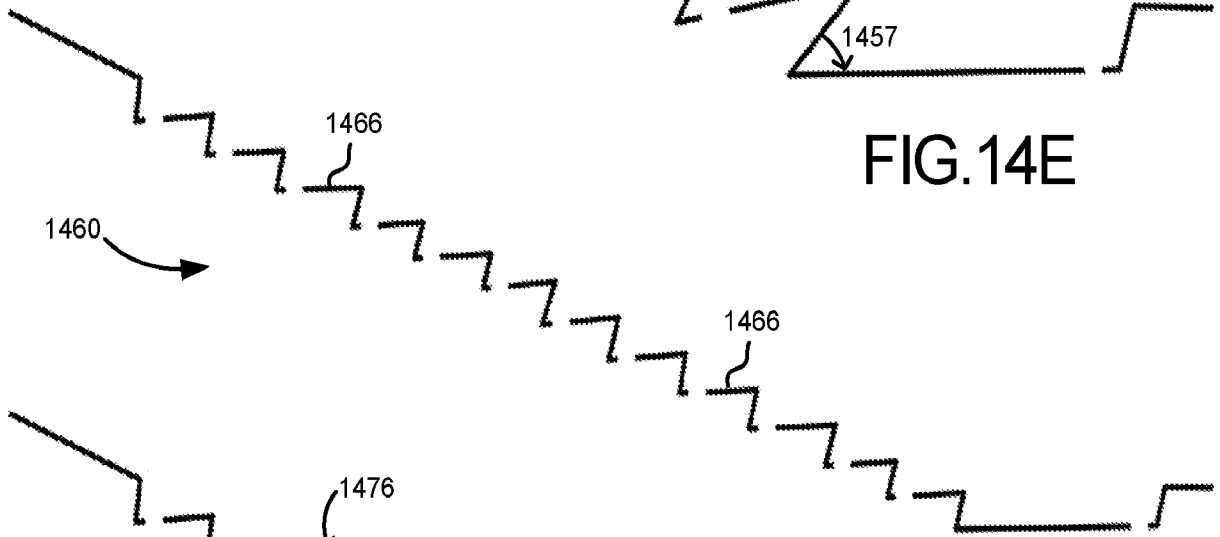

FIG. 14F

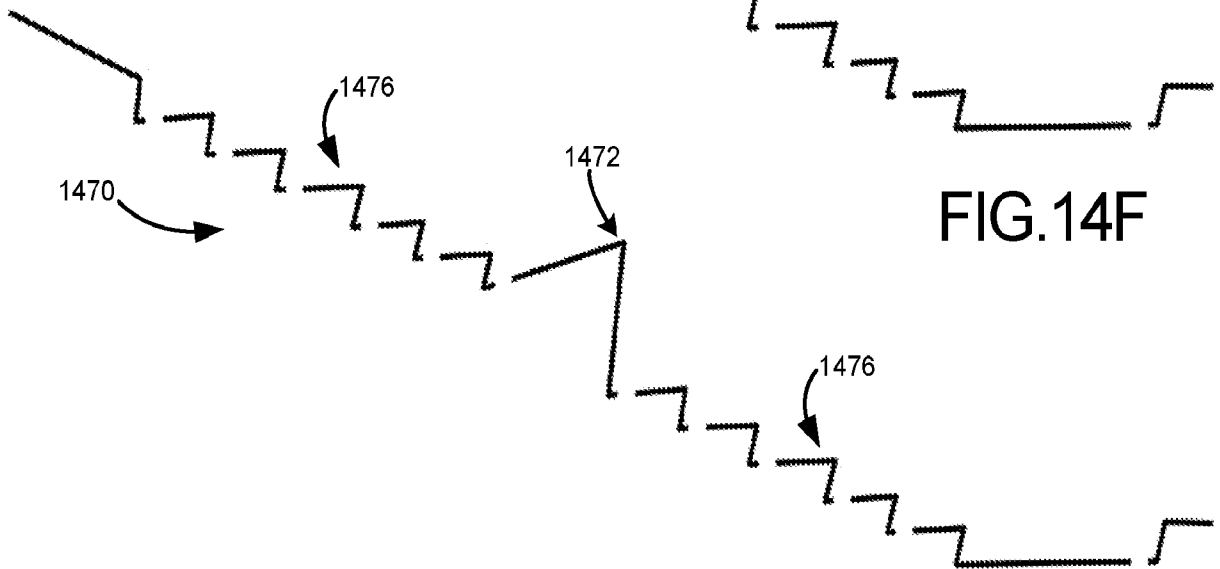

FIG. 14G

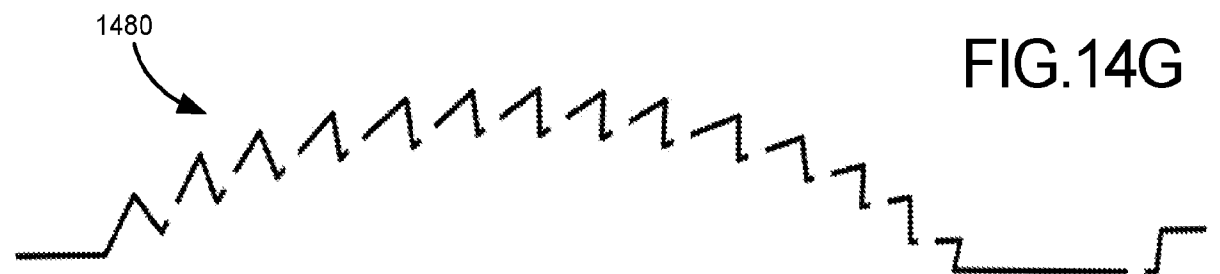

FIG. 14H

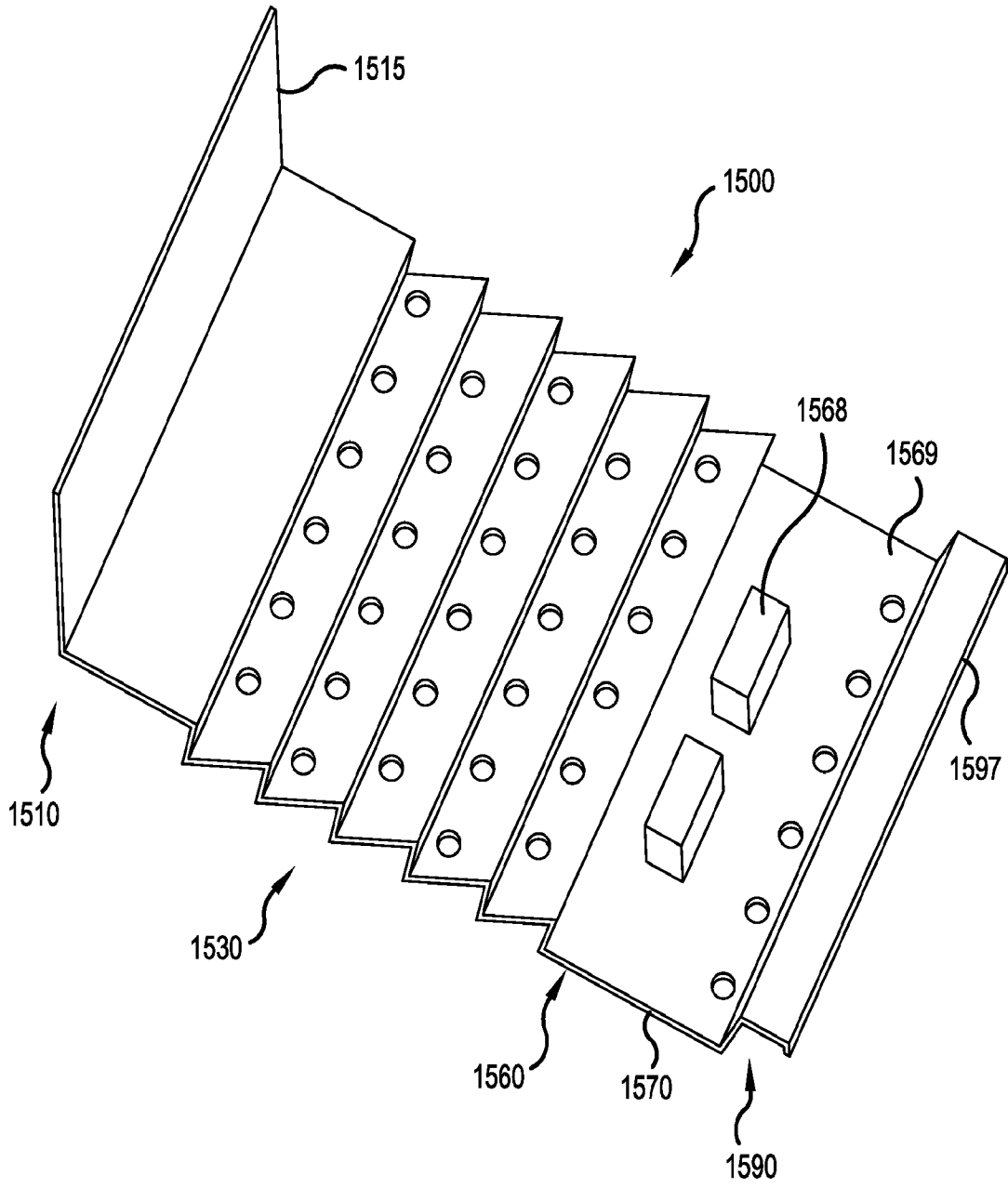

FIG.15

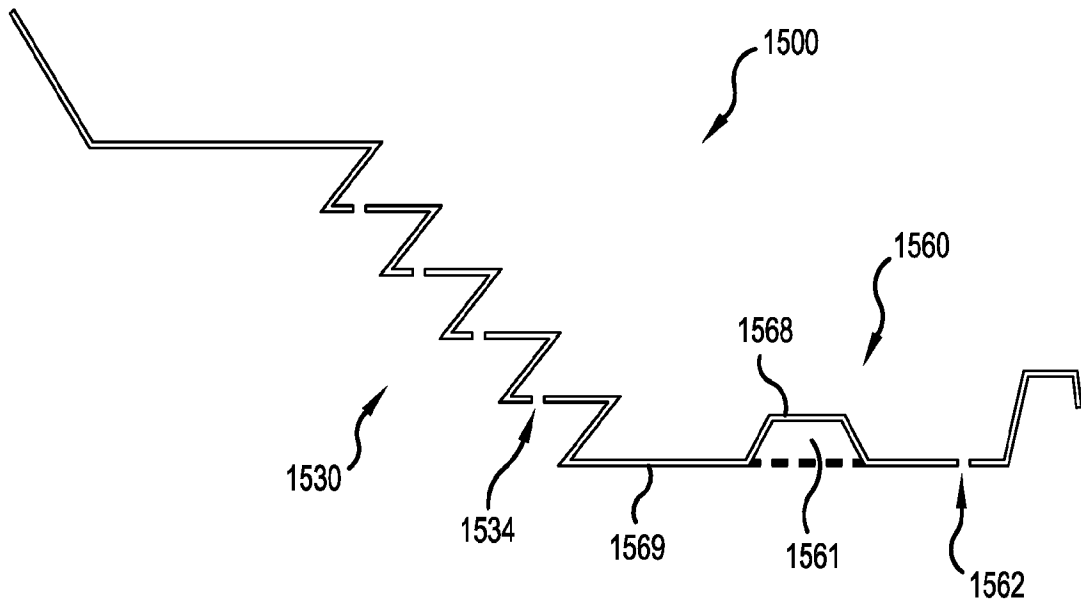

FIG.16

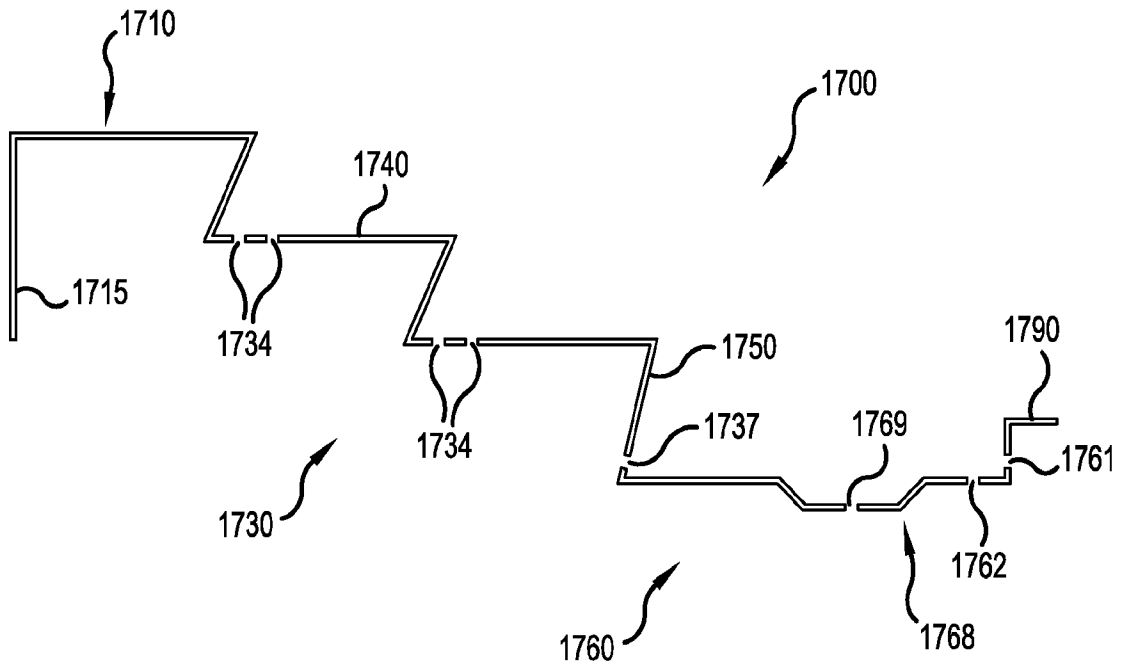

FIG.17

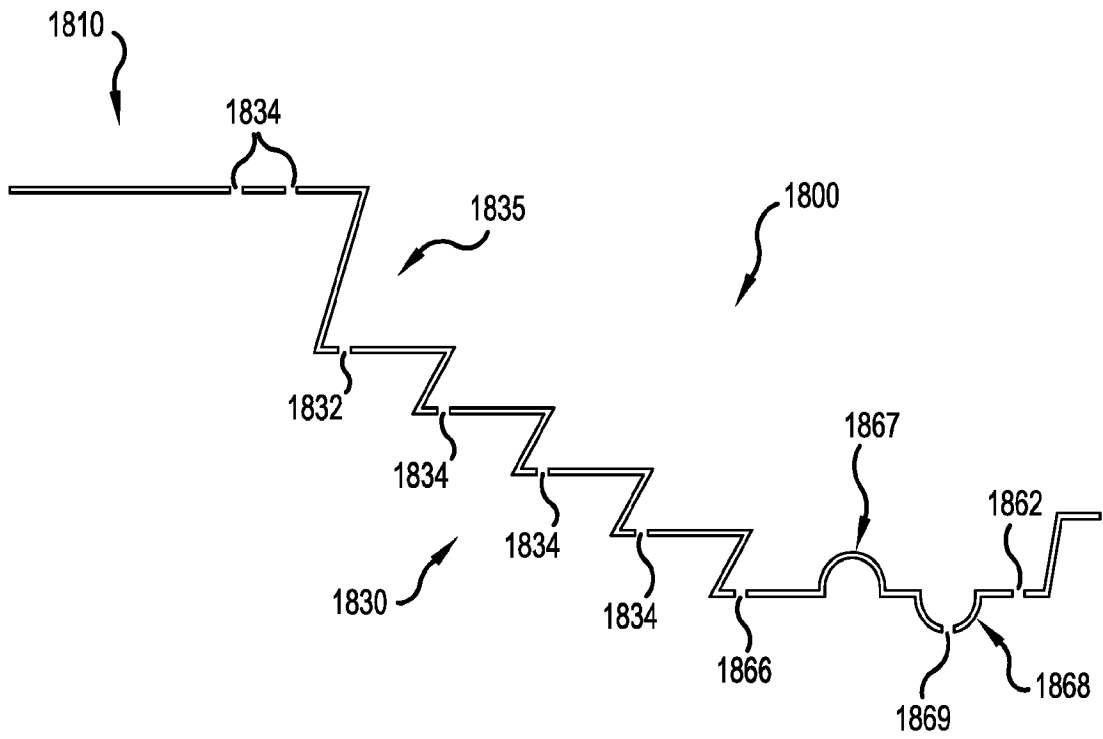

FIG.18

29/31

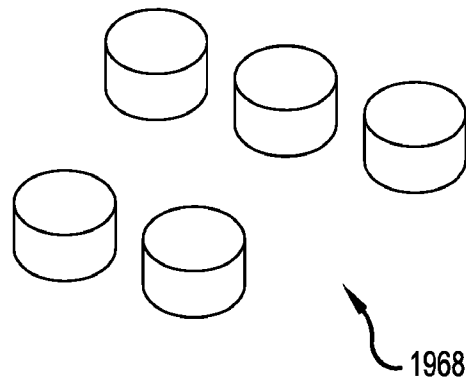

FIG.19

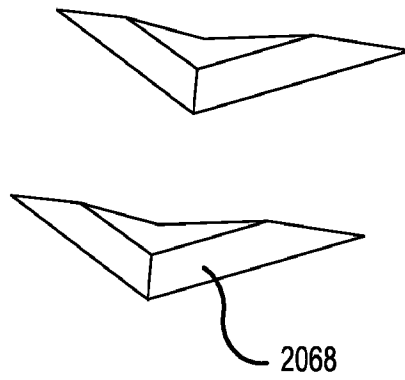

FIG.20

30/31

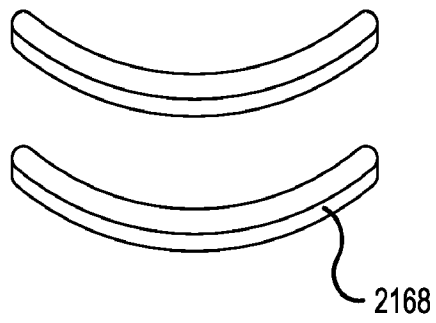

FIG. 21

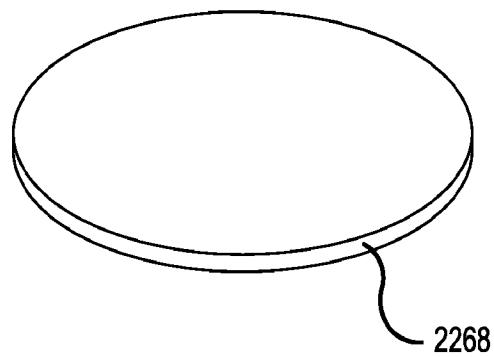

FIG. 22

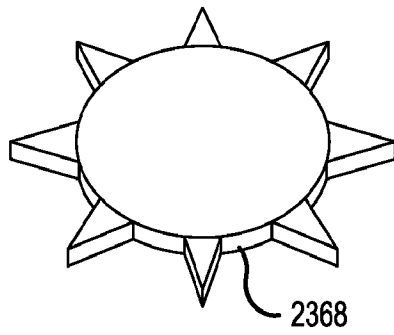

FIG.23

INTERNATIONAL SEARCH REPORT

International application No.

PCT/US 20/40383

A. CLASSIFICATION OF SUBJECT MATTER
 IPC - E04D 13/076; E04D 13/064; E02B 5/08 (2020.01)
 CPC - E04D 13/076; E04D 13/064; E04D 13/15

According to International Patent Classification (IPC) or to both national classification and IPC

B. FIELDS SEARCHED

Minimum documentation searched (classification system followed by classification symbols)
 See Search History document

Documentation searched other than minimum documentation to the extent that such documents are included in the fields searched
 See Search History document

Electronic data base consulted during the international search (name of data base and, where practicable, search terms used)
 See Search History document

C. DOCUMENTS CONSIDERED TO BE RELEVANT

Category*	Citation of document, with indication, where appropriate, of the relevant passages	Relevant to claim No.
X	US 2015/0089883 A1 (Peck et al.) 02 April 2015 (02.04.2015), entire document, especially Fig. 1, 2B, 3; para [0029], [0030], 0034]	1-8, 12-16, 22-26
Y		10, 17-21
X	GB 2,351,757 A (CDS Marketing Limited) 10 January 2001 (10.01.2001), entire document, especially Fig. 1	1, 9, 11
Y	US 7,104,012 B1 (Bayram) 12 September 2006 (12.09.2006), entire document, especially Fig. 1 and 3	10
Y	US 2009/0320381 A1 (Gerig) 31 December 2009 (31.12.2009), entire document, especially Fig. 1, 3; title, abstract, para [0022]	17-21
A	US 2008/0127575 A1 (Ealer) 05 June 2008 (05.06.2008), entire document	1-26
A	US 6,161,338 A (Kuhns) 19 December 2000 (19.12.2000), entire document	1-26

Further documents are listed in the continuation of Box C.

See patent family annex.

* Special categories of cited documents:

"A" document defining the general state of the art which is not considered to be of particular relevance

"D" document cited by the applicant in the international application

"E" earlier application or patent but published on or after the international filing date

"L" document which may throw doubts on priority claim(s) or which is cited to establish the publication date of another citation or other special reason (as specified)

"O" document referring to an oral disclosure, use, exhibition or other means

"P" document published prior to the international filing date but later than the priority date claimed

"T" later document published after the international filing date or priority date and not in conflict with the application but cited to understand the principle or theory underlying the invention

"X" document of particular relevance; the claimed invention cannot be considered novel or cannot be considered to involve an inventive step when the document is taken alone

"Y" document of particular relevance; the claimed invention cannot be considered to involve an inventive step when the document is combined with one or more other such documents, such combination being obvious to a person skilled in the art

"&" document member of the same patent family

Date of the actual completion of the international search

17 August 2020

Date of mailing of the international search report

25 SEP 2020

Name and mailing address of the ISA/US

Mail Stop PCT, Attn: ISA/US, Commissioner for Patents
 P.O. Box 1450, Alexandria, Virginia 22313-1450
 Facsimile No. 571-273-8300

Authorized officer

Lee Young

Telephone No. PCT Helpdesk: 571-272-4300