



US00RE38179E

(19) **United States**
(12) **Reissued Patent**
Elsässer et al.

(10) **Patent Number:** **US RE38,179 E**
(45) **Date of Reissued Patent:** **Jul. 8, 2003**

- (54) **DISK STORAGE DEVICE HAVING A THREE-PHASE BRUSHLESS DC UNDERHUB CONFIGURED SPINDLE MOTOR**
 - Dec. 5, 1980 (DE) 3045972
 - Sep. 7, 1981 (DE) 3135385
 - Jun. 1, 1984 (CH) 2680/84
 - Mar. 30, 1985 (CH) 1374/85
- (75) Inventors: **Dieter Elsässer, St. Georgen (DE); Johann von der Heide, Schramberg (DE); Rolf Müller, Munich (DE)**
- (51) **Int. Cl.⁷ G11B 17/08**
- (52) **U.S. Cl. 360/98.07; 360/97.02; 360/99.08**
- (73) Assignee: **Papst Licensing GmbH & Co. KG, St. Georgen (DE)**
- (58) **Field of Search 360/98.07, 98.08, 360/99.08, 99.12**
- (*) Notice: This patent is subject to a terminal disclaimer.
- (56) **References Cited**

(21) Appl. No.: **09/333,400**
(22) Filed: **Jun. 18, 1999**

Related U.S. Patent Documents

Reissue of:

- (64) Patent No.: **5,173,814**
- Issued: **Dec. 22, 1992**
- Appl. No.: **07/653,100**
- Filed: **Feb. 8, 1991 U.S. Applications:**

(63) Continuation of application No. 08/819,099, filed on Mar. 4, 1997, now Pat. No. Re. 37,058, which is a continuation of application No. 08/360,226, filed on Dec. 20, 1994, now abandoned, which is a continuation of application No. 07/402,917, filed on Sep. 5, 1989, now Pat. No. 5,001,581, which is a continuation of application No. 07/201,736, filed on Jun. 2, 1988, now Pat. No. 4,894,738, which is a continuation-in-part of application No. 07/038,049, filed on Apr. 14, 1987, now Pat. No. 4,843,500, which is a continuation-in-part of application No. 06/767,671, filed on Aug. 21, 1985, now Pat. No. 4,658,312, which is a continuation of application No. 06/412,093, filed on Aug. 27, 1982, now abandoned, and application No. 06/326,559, filed on Dec. 2, 1981, now Pat. No. 4,519,010, which is a continuation-in-part of application No. 06/244,971, filed on Mar. 18, 1981, now abandoned, said application No. 07/201,736, is a continuation-in-part of application No. 07/032,954, filed on Mar. 31, 1987, now Pat. No. 4,779,165, which is a continuation of application No. 07/733,231, filed on May 10, 1985, now abandoned, which is a continuation-in-part of application No. 06/412,093, said application No. 06/767,671, is a continuation-in-part of application No. 06/617,629, filed on Jun. 6, 1984, now Pat. No. 4,556,829.

(30) **Foreign Application Priority Data**

May 10, 1980 (CH) 3568/80

U.S. PATENT DOCUMENTS

- 3,250,929 A 5/1966 Maier
- 3,290,525 A 12/1966 Sudmeier
- 3,329,845 A 7/1967 Lear
- 3,527,969 A 9/1970 Papst
- 3,596,121 A 7/1971 Chang
- 3,634,873 A 1/1972 Nishimura
- 3,691,542 A 9/1972 Gabor
- 3,706,085 A 12/1972 Mowrey
- 3,732,025 A 5/1973 Miles, Jr.
- 3,805,134 A 4/1974 Osamu
- 3,840,761 A 10/1974 Müller
- 3,845,339 A 10/1974 Muzkle
- 3,849,800 A 11/1974 Czuzner
- 3,860,843 A 1/1975 Kawasaki
- 3,864,610 A 2/1975 Kawamoto
- 3,864,748 A 2/1975 Herdman
- 3,873,897 A 3/1975 Müller
- 3,888,403 A 6/1975 Yoshida
- 3,891,905 A 6/1975 Müller
- 3,922,590 A 11/1975 Warren
- 3,940,670 A 2/1976 Tanikoshi
- 3,967,200 A 6/1976 Tetsugu et al.
- 3,977,804 A 8/1976 Kitagawa
- 3,988,024 A 10/1976 Watanabe et al.
- 4,005,490 A 1/1977 Duncan et al.
- 4,008,422 A 2/1977 Sodekoda et al.
- 4,031,558 A 6/1977 Kusaka
- 4,034,411 A 7/1977 Kraemer et al.
- 4,054,931 A 10/1977 Bolton
- 4,062,049 A 12/1977 Dirks
- 4,092,572 A 5/1978 Murata
- 4,099,104 A 7/1978 Müller
- 4,101,945 A 7/1978 Butsch
- 4,115,715 A 9/1978 Müller

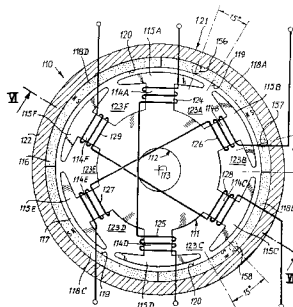
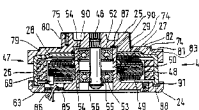

US RE38,179 E

Page 2

4,130,845 A	12/1978	Kulma	RE32,702 E	6/1988	Hasler et al.
4,136,366 A	1/1979	Ogiro et al.	4,754,351 A	6/1988	Wright
4,150,406 A	4/1979	Stollorz	4,779,165 A	10/1988	Elsässer et al.
4,167,692 A	9/1979	Sekiya et al.	4,780,777 A	10/1988	Biermeier
4,174,484 A	11/1979	Schmider	4,797,762 A	1/1989	Levy et al.
4,181,867 A	1/1980	Müller	4,805,055 A	2/1989	Wright
4,185,308 A	1/1980	Fujioka	4,814,652 A	3/1989	Wright
4,190,870 A	2/1980	Avina et al.	4,829,657 A	5/1989	Wright
4,193,646 A	3/1980	Rocki	4,843,500 A	6/1989	Elsässer et al.
4,194,225 A	3/1980	Hasler	4,882,511 A	11/1989	von der Heide
4,194,743 A	3/1980	Ohsawa et al.	4,905,110 A *	2/1990	Krum et al. 360/99.08
4,197,489 A	4/1980	Dunn et al.	4,922,406 A	5/1990	Schuh
4,216,512 A	8/1980	Widwans	4,928,029 A	5/1990	Wright
4,228,387 A	10/1980	Brown	4,949,000 A	8/1990	Petersen
4,249,221 A	2/1981	Cox et al.	4,991,211 A	2/1991	Cap
4,252,353 A	2/1981	Raj	5,001,581 A	3/1991	Elsässer et al.
4,268,878 A	5/1981	Kearns	5,006,943 A	4/1991	Elsässer et al.
4,275,339 A	6/1981	Burke et al.	5,040,085 A	8/1991	Elsässer et al.
4,280,072 A	7/1981	Gotou et al.	5,128,819 A	7/1992	Elsässer et al.
4,280,155 A	7/1981	Scott et al.	5,173,814 A	12/1992	Elsässer et al.
4,282,554 A	8/1981	Ho	5,216,557 A	6/1993	Elsässer et al.
4,283,644 A	8/1981	Kondo et al.	RE34,412 E	10/1993	Elsässer et al.
4,285,016 A	8/1981	Gilovich	5,251,081 A	10/1993	Cossette et al.
4,286,184 A	8/1981	Kogler et al.	5,382,853 A	1/1995	von der Heide et al.
4,307,425 A	12/1981	Kaneko et al.	5,422,769 A	6/1995	Elsässer et al.
4,317,146 A	2/1982	Gervais	5,424,887 A	6/1995	Schuh
4,329,604 A	5/1982	Dunstan et al.	5,446,610 A	8/1995	Elsässer et al.
4,329,722 A	5/1982	West	5,557,487 A	9/1996	Elsässer et al.
4,336,470 A	6/1982	Gutris	5,661,351 A	8/1997	von der Heide et al.
4,337,491 A	6/1982	Hasler et al.	5,708,539 A	1/1998	Schuh
4,352,133 A	9/1982	Hager	5,729,403 A	3/1998	Schuh
4,356,437 A	10/1982	Saito et al.	RE35,792 E	5/1998	Elsässer et al.
4,359,761 A	11/1982	Papst	5,774,302 A	6/1998	Elsässer et al.
4,363,046 A	12/1982	Saito	5,777,822 A	7/1998	Schuh
4,363,057 A	12/1982	Siverling et al.	5,801,900 A	9/1998	Elsässer et al.
4,365,187 A	12/1982	McDaniel et al.	RE36,016 E	12/1998	Cap et al.
4,365,916 A	12/1982	Miyakawa	5,946,161 A	8/1999	Schuh
4,366,516 A	12/1982	Ogata			
4,394,594 A	7/1983	Schmider et al.			
4,396,959 A	8/1983	Harrison et al.	CH	654 455 A5	2/1986
4,396,964 A	8/1983	Morehouse et al.	DE	1244283	7/1967
4,398,134 A	8/1983	Müller	DE	1954409	6/1970
4,417,167 A	11/1983	Ishii et al.	DE	2028228	12/1970
4,430,603 A	2/1984	Müller	DE	2319579	4/1973
4,438,542 A	3/1984	Schuh	DE	2225442	12/1973
4,445,159 A	4/1984	Nemoto	DE	2346380	11/1974
4,471,395 A	9/1984	Beck et al.	DE	2639055	3/1977
4,497,138 A	2/1985	Schreiber	DE	2612464	8/1977
4,516,177 A	5/1985	Moon et al.	DE	26 17 860	11/1977
4,519,010 A	5/1985	Elsässer et al.	DE	2804787	9/1978
4,529,900 A	7/1985	Uzuka	DE	2840057	3/1979
4,535,373 A	8/1985	Schuh	DE	2647675	4/1979
4,553,183 A	11/1985	Brown et al.	DE	2749729	5/1979
4,554,473 A	11/1985	Müller	DE	2841137	5/1979
4,562,496 A	12/1985	Saito et al.	DE	3122049 A1	6/1981
RE32,075 E	1/1986	Harrison et al.	DE	3049334	10/1981
4,599,664 A *	7/1986	Schuh 360/99.08	DE	3122049	7/1982
4,607,182 A	8/1986	Ballhaus	DE	3144629 A1	7/1982
4,616,538 A	10/1986	Hessbrüggen	DE	3135385 A1	3/1983
4,656,545 A	4/1987	Kakuta	DE	3314079	12/1983
4,658,312 A	4/1987	Elsässer et al.	DE	3538480	4/1986
4,672,250 A	6/1987	Seitz	EP	0 069 545	1/1983
4,672,487 A	6/1987	Brand et al.	EP	0 015 739	4/1983
4,692,827 A	9/1987	Biermeier et al.	EP	0094484 A1	11/1983
4,701,653 A	10/1987	Merkle	EP	0 107 380	2/1984
4,717,977 A	1/1988	Brown	EP	0 151 259	4/1985
4,725,904 A	2/1988	Dalziel	EP	0151258 A1	8/1985
4,739,203 A	4/1988	Miyao et al.	EP	0151260 A1	8/1985
4,739,425 A	4/1988	Dierkes et al.	EP	0 172 459	2/1986
4,739,427 A	4/1988	Kilmer et al.	EP	0 263 932	4/1988
4,743,995 A	5/1988	Castle et al.	FR	2415859	8/1979

FOREIGN PATENT DOCUMENTS

FR	2453527	10/1980
GB	393617	6/1933
GB	1407431	8/1972
GB	1328717	8/1973
GB	1434192	5/1976
GB	1486070	9/1977
GB	2005482	4/1979
GB	2013388	8/1979
GB	2032197	4/1980
GB	1572586	7/1980
GB	2072924	10/1981
GB	2075240	11/1981
GB	1604121	12/1981
GB	2092834 A	8/1982
GB	2166586	5/1986
GB	2195812	4/1988
JP	53-55509	10/1951
JP	41-015606	9/1966
JP	41-021084	9/1966
JP	49-34714	6/1972
JP	50-6313	5/1973
JP	48-86510	11/1973
JP	48-87809	11/1973
JP	49-46716	5/1974
JP	49-71909	7/1974
JP	49-85110	7/1974
JP	50-90905	7/1975
JP	50-128510	10/1975
JP	50-146309	11/1975
JP	50-152708	12/1975
JP	50-159704	12/1975
JP	51-33410	3/1976
JP	50-128506	3/1976
JP	51-57011	5/1976
JP	51-62002	5/1976
JP	51-26669	7/1976
JP	51-84516	7/1976
JP	51-121306	10/1976
JP	51-151513	12/1976
JP	52-6914	1/1977
JP	52-004002	1/1977
JP	52-42209	3/1977
JP	52-50704	4/1977
JP	52-048009	4/1977
JP	52-145312	11/1977
JP	52-170004	12/1977
JP	53-23010	3/1978
JP	53-39727	4/1978
JP	53-51719	5/1978
JP	53-55106	5/1978
JP	53-57010	5/1978
JP	53-055724	5/1978
JP	53-70309	6/1978
JP	53-76809	7/1978
JP	54-41619	3/1979
JP	54-9921	5/1979
JP	54-58011	5/1979
JP	54-66416	5/1979
JP	55-170495	5/1979
JP	Sho 56-25997	8/1979
JP	54-099908	8/1979
JP	54-111317	8/1979
JP	54-121914	9/1979
JP	54-139819	9/1979
JP	54-136309	10/1979
JP	54-156106	12/1979
JP	55-43360	3/1980
JP	55-141258	4/1980
JP	Sho 55-117486	9/1980
JP	55-139674	10/1980
JP	55-25725	12/1980

JP	Sho 56-3592	1/1981
JP	56-9594	1/1981
JP	56-107364	8/1981
JP	56-121360	9/1981
JP	56-166760	12/1981
JP	57-53876	3/1982
JP	57-171532	10/1982
JP	58-22571	2/1983
JP	58-30965	2/1983
JP	58-30312	4/1983
JP	58-86892	5/1983
JP	58-130786	8/1983
JP	58-159201	9/1983
JP	58-200480	11/1983
JP	59-22273	2/1984
JP	59-207069	11/1984
JP	61-34771	2/1986
JP	61-20871	6/1986
WO	WO 80/01525	7/1980
WO	8401863	5/1984

OTHER PUBLICATIONS

"DC Servomotors for Mechatronics," Sogo Electronics Publishing Company, Tokyo (Sogo Denshi Shuppansha), 4th Print, 1984, by Takashi Kenjo and Shigenobu Nagamori, pp. 69-75, 78-79.

"Permanent Magnet and Brushless DC Motors," translated by Takashi Kenjo, Revised and slated verion of "DC Servomotors for Mechatronics," Sogo Electronics Publishing Company, Tokyo 1984, pp. 58-69.

DC Brushless Motor and Control Circuit, 1984 by Kinji Tanigoshi, pp. 7-15, pp. 44-47, pp. 60-65 and pp. 78-79.

Drawing "GAE Motor" (1 sheet) Papst Motoren GmbH & Co. KG.

Drawing "Motor 9333 5310 001" (2 sheets) Papst Motoren GmbH & Co. KG.

Zweipulsige Kollektorlose Gleichstrom Motoren (No Month) 1977; Papst Motoren KG., Germany.

Brushless DC Drive Spindle "Sextant", Rotron, Inc., Woodstock, N.Y., Nov. 17, 1980.

Kobayashi et al., "Direct Drive System For Isolated Loop Drive." National Technical Report, vol. 22, No. 4, Aug. 1976.

"Who Need High Capacites?," M. Pearce, *Computer Systems*, Nov. 1983, pp. 81-84.

"Motor in spindle gives micro-Winchester room for 140M bytes", J. Swartz, *Mini-Micro Systems*, Feb. 1983. pp. 143-144, 147-148.

An Overview of the Sperry Flight Management Computer system for the Boeing 757/767 Airplanes (1979).

Plastic Ridge Seal to Trap Airborne Submicron Particles, V.J. Trotter, Jr. *IBM Technical Disclosure Bulletin*, vol. 19, No. 4 Sep. 1976.

Fixed-Head Disk Memory Unit for High Reliability Applications, Isozaki et al. *NEC Research & Development*, No. 44 Jan. 1977 at pp. 57-67.

Hardware Maintenance Manual for Control Data Fixed Disk Drive Model 9414.

German article entitled: "Diskettenantrieb im Mini-Floppy-Laufwerk," taken from *VCI-Berichte Nr. 482* Von Ing. (Grad.) K. Schramm, Nurnberg., pp. 56-59 (1983).

German brochure entitled: "P.M. Computerheft—*Computer Entdecken Und Vertehen*", pp. 49-51 (Feb. 1984).

"Machine Tools, New Edition", Ito et al., Published 1970.

"American Metal Market, V. 92 (p. 10), Jan. 30, 1984: Composites Used Extensively In Buick Tin-Plating Systems".

Machinery and Production Engineering, V. 116, N. 3003 (pp. 861-862), 1970 "Universal Power Chucks Facilitate Small Batch Production".

Production, V. 93, No. 5, May 1984 "Spotlight On Machining Centers".

"Cutting Edge Control Motors", *Mechatro Books* 1, Feb. 10, 1984, Feb. 27, 1984.

"Complete Study on VCRs" '81-IV Radio Technology Nov. Special Issue Nov. 25, 1981.

* cited by examiner

Primary Examiner—A. J. Heinz

(74) *Attorney, Agent, or Firm*—Welsh & Katz, Ltd.

(57)

ABSTRACT

A disk memory drive includes a brushless drive outer rotor motor having an internal space and a stator with windings. The outer rotor coaxially encircles the stator and a substantially cylindrical air gap is defined between the stator and the rotor. The rotor includes permanent magnets and a hub fixedly connected with the magnet. A disk mounting section is provided on the hub for accommodating at least one storage disk positioned in a clear space, the mounting section being adapted to extend through a central aperture of the storage disk. The windings and the magnets interacting with the windings are disposed for at least half of the axial longitudinal dimension thereof within a space surrounded by the disk mounting section of the hub. Bearings rotatably mount the rotor and the hub.

15 Claims, 10 Drawing Sheets

FIG. 1

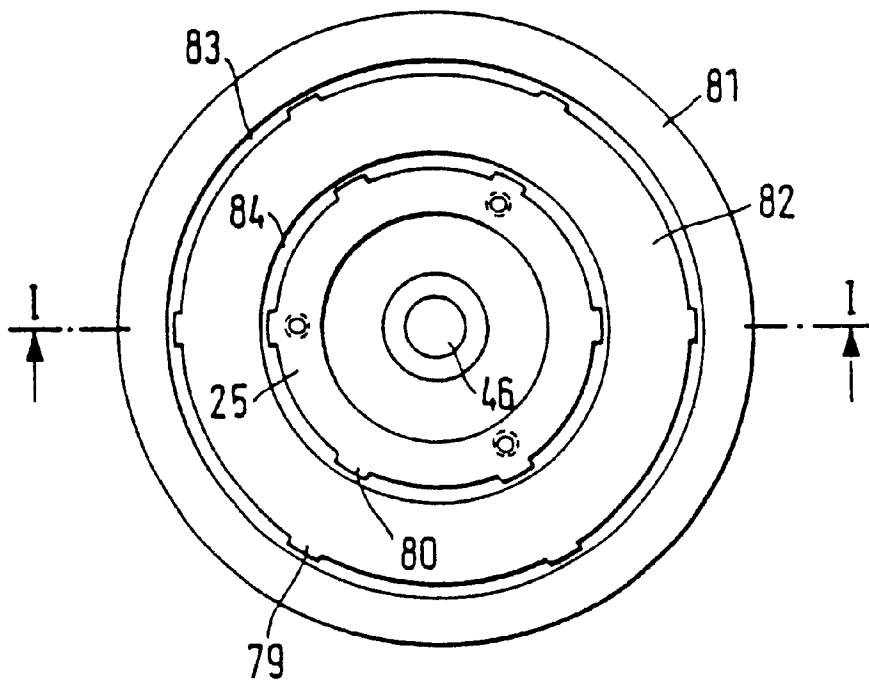
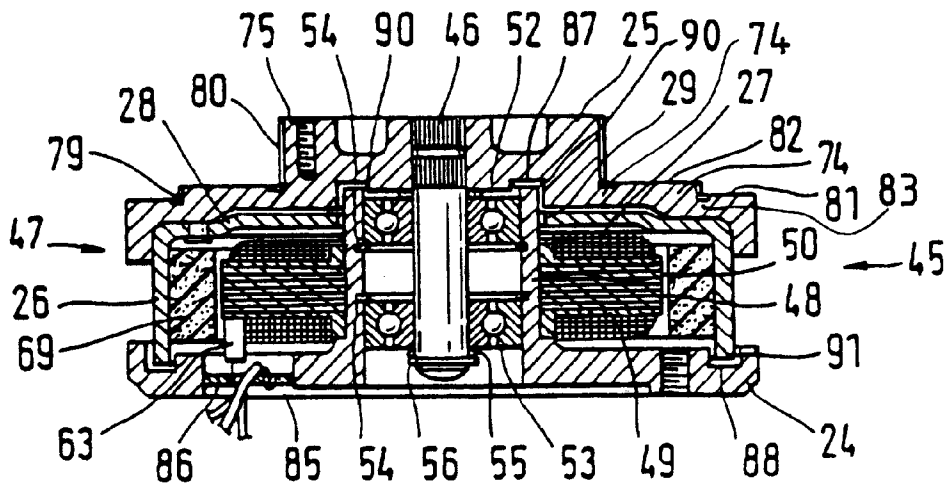

FIG. 2

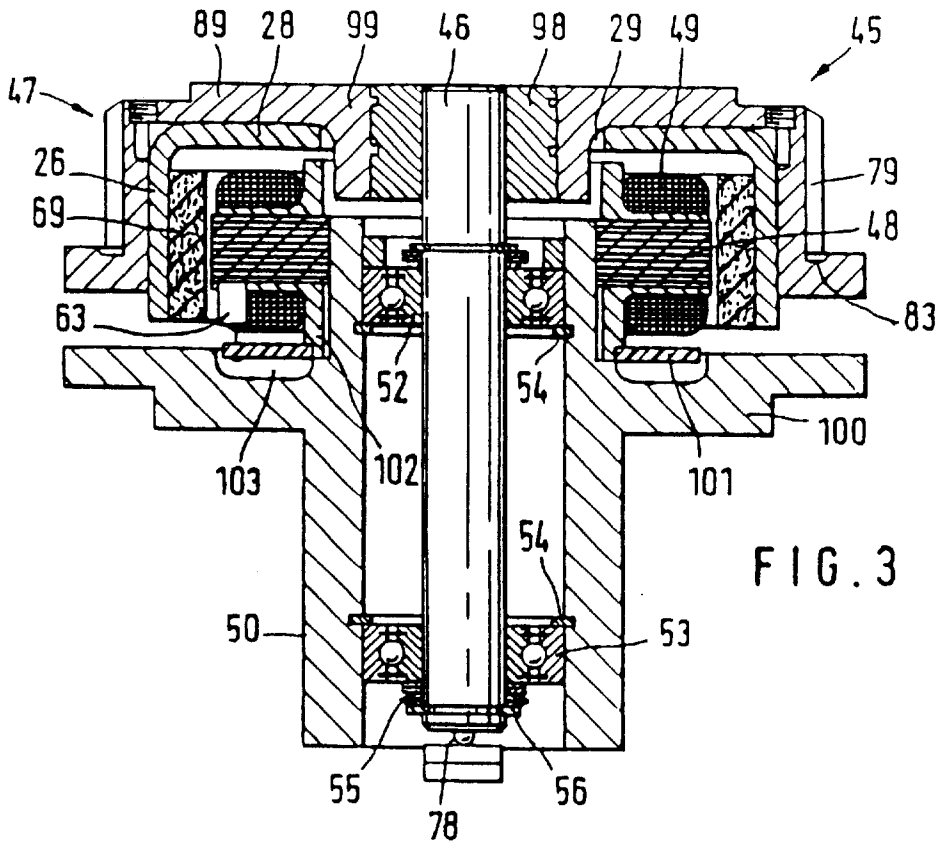

FIG. 3

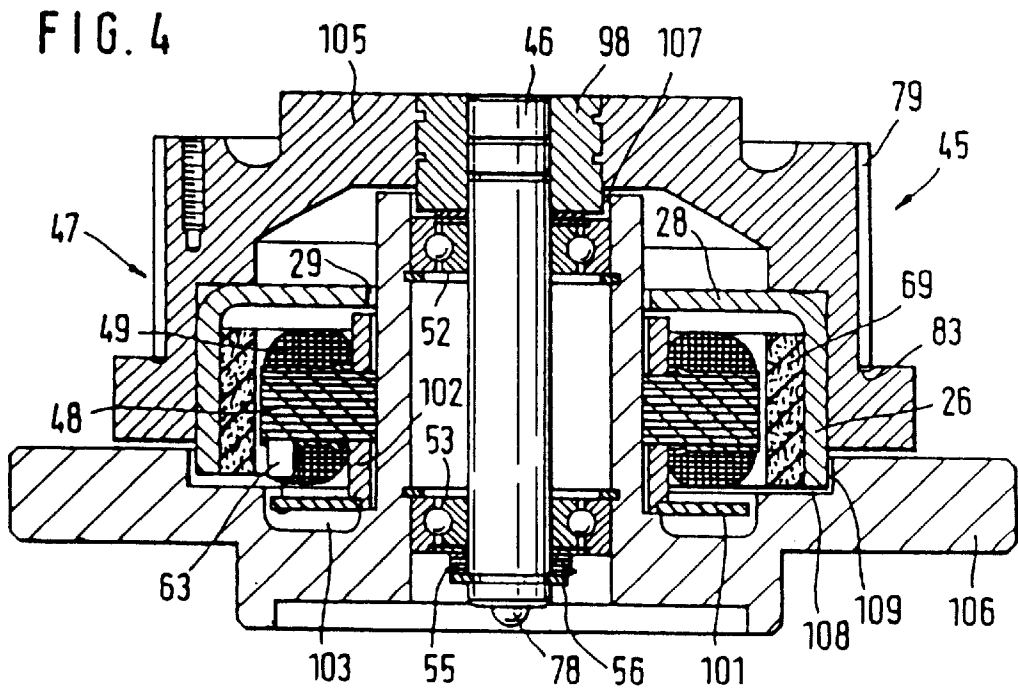
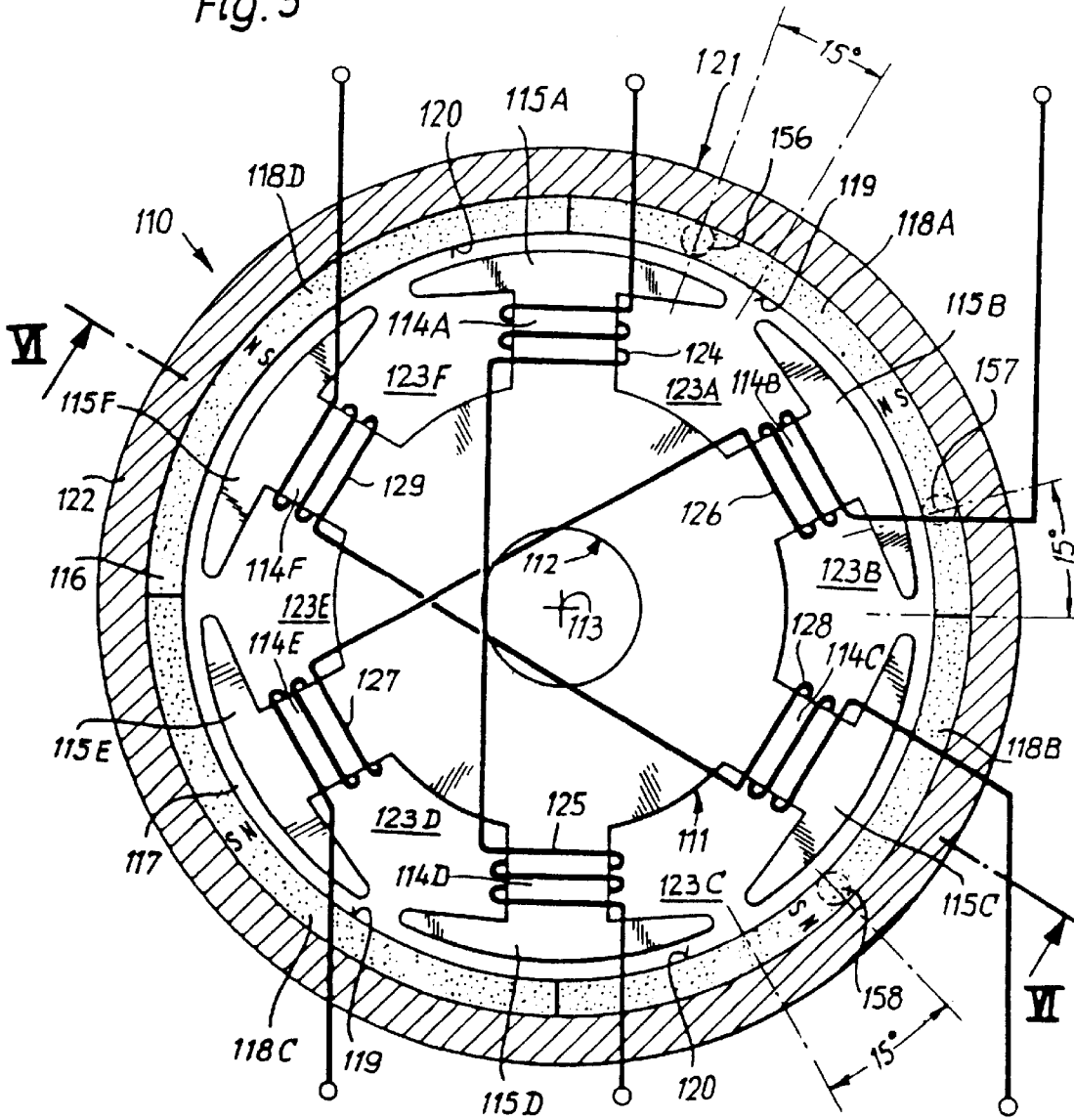

FIG. 4

Fig. 5



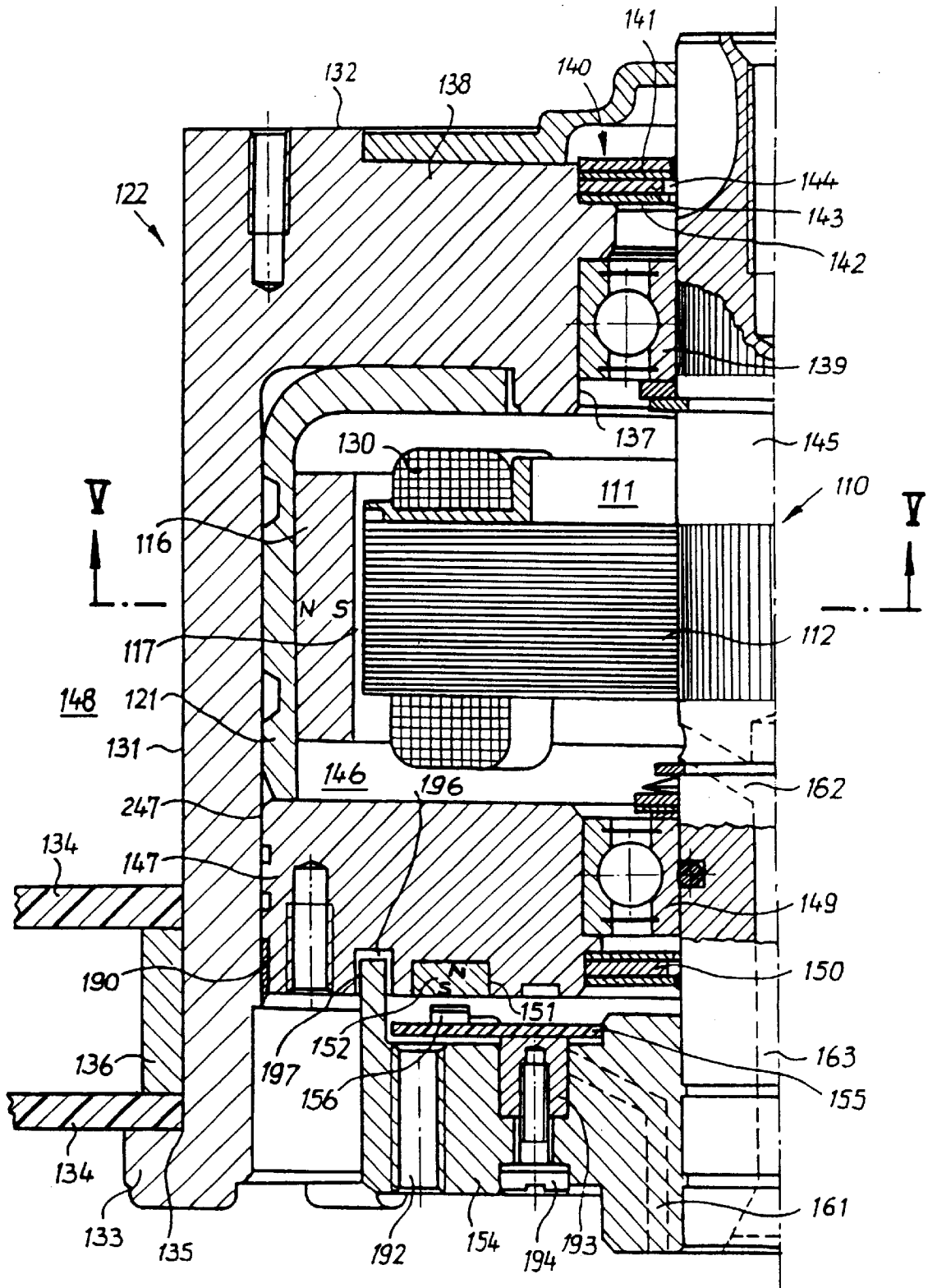

Fig. 6

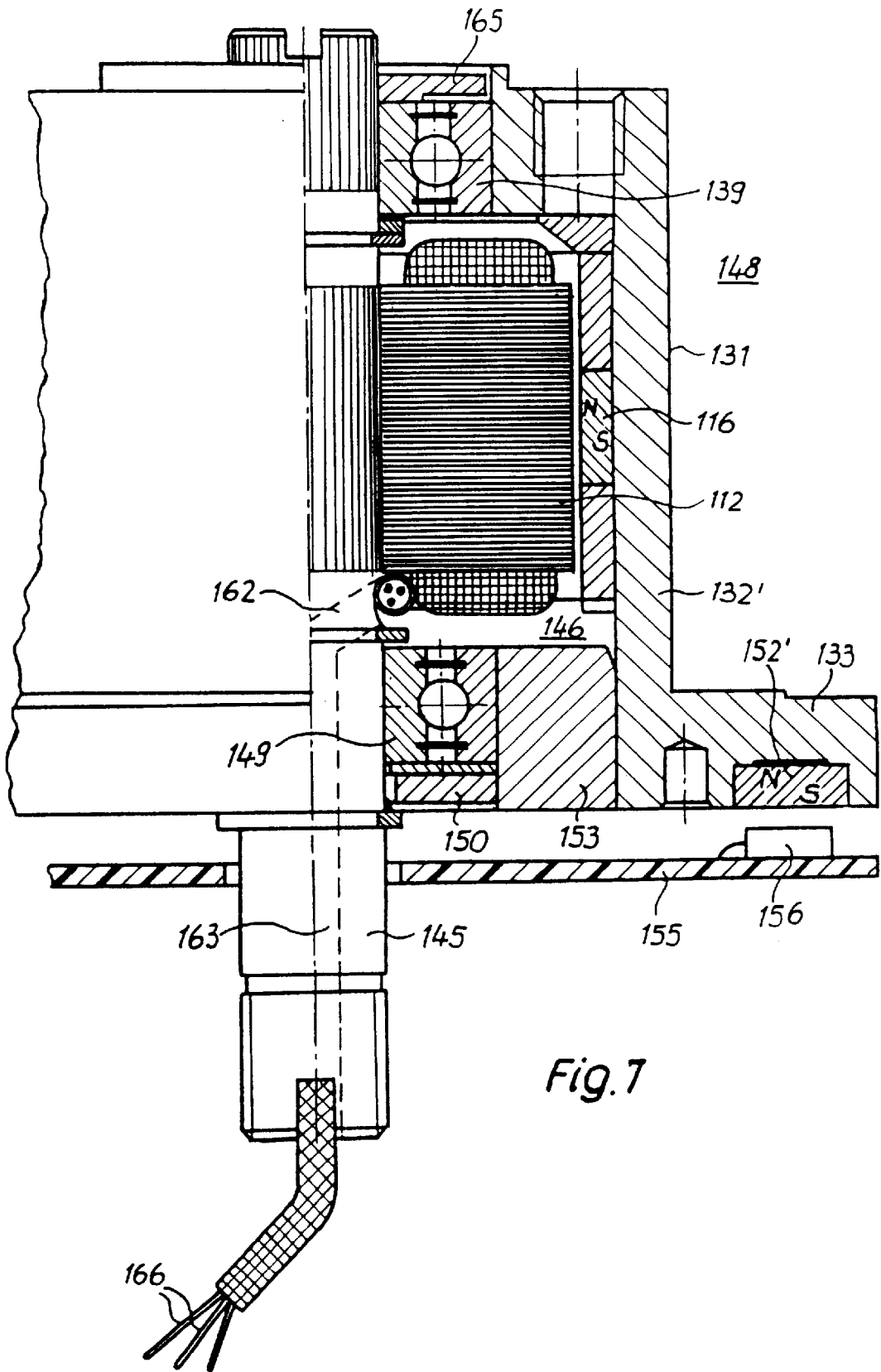

Fig. 7

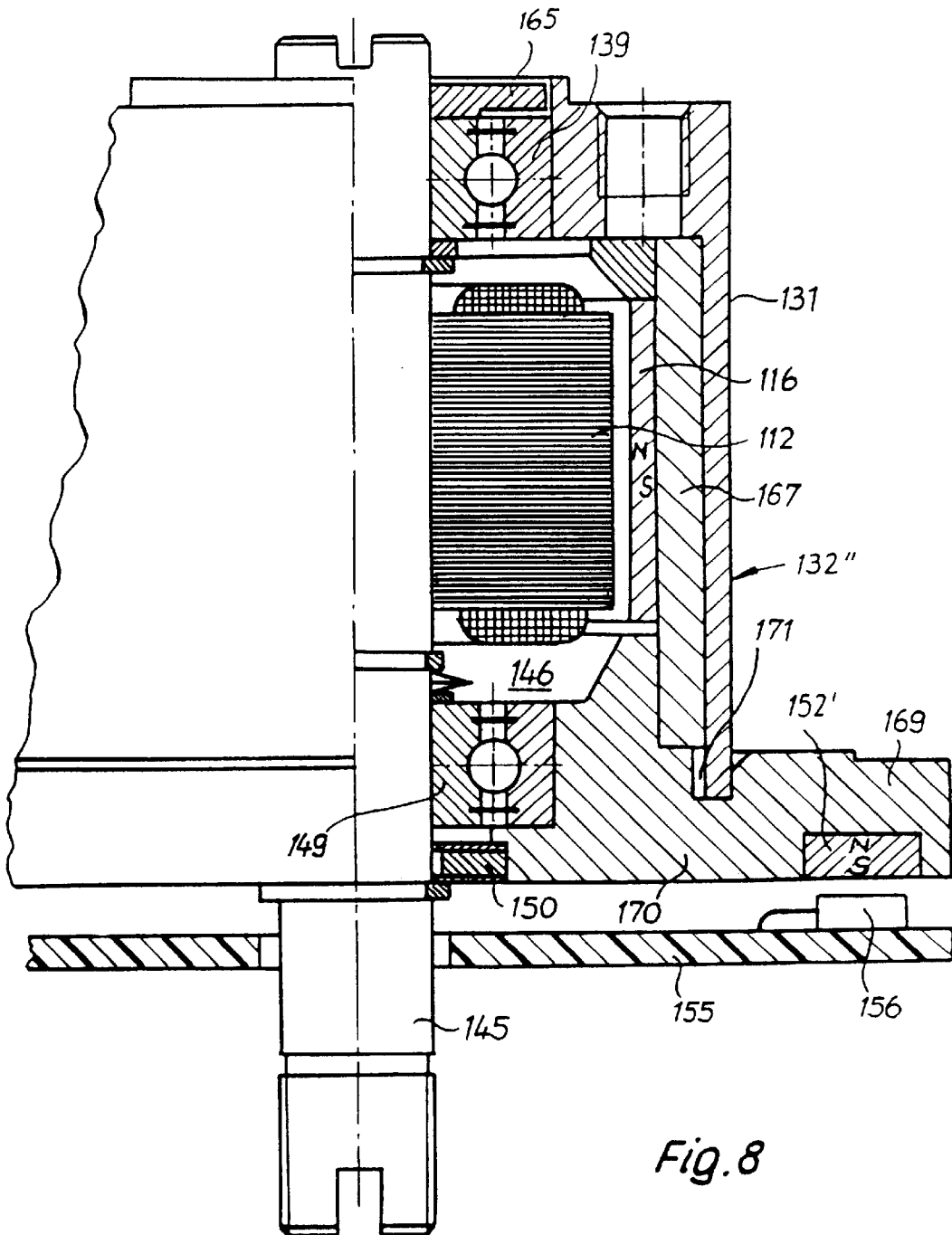

Fig. 8

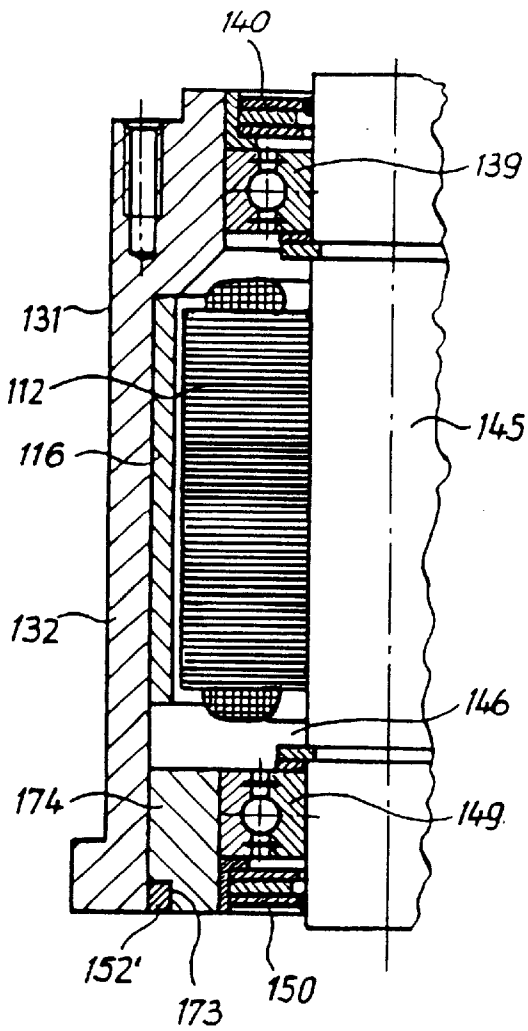

Fig. 9

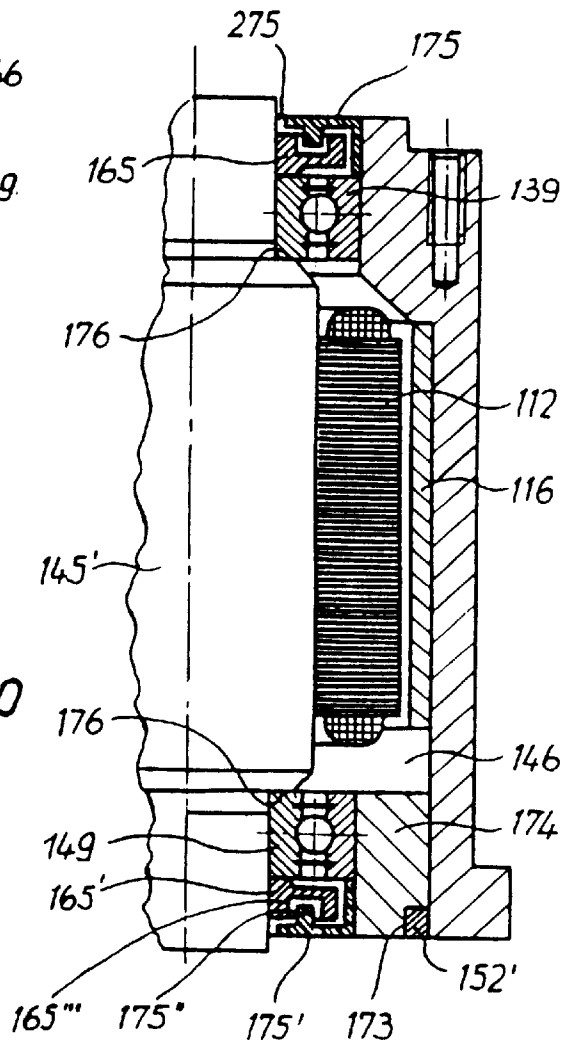
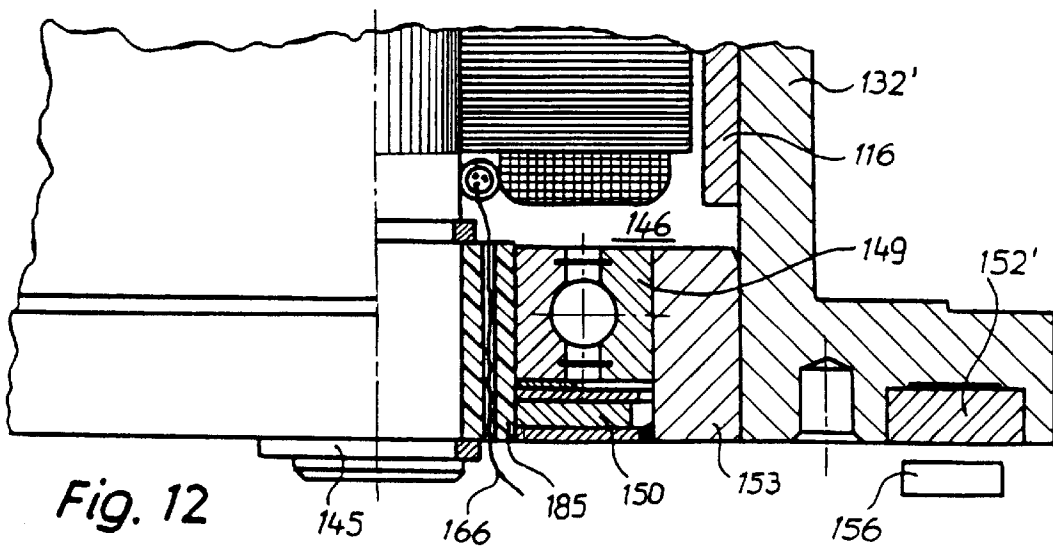
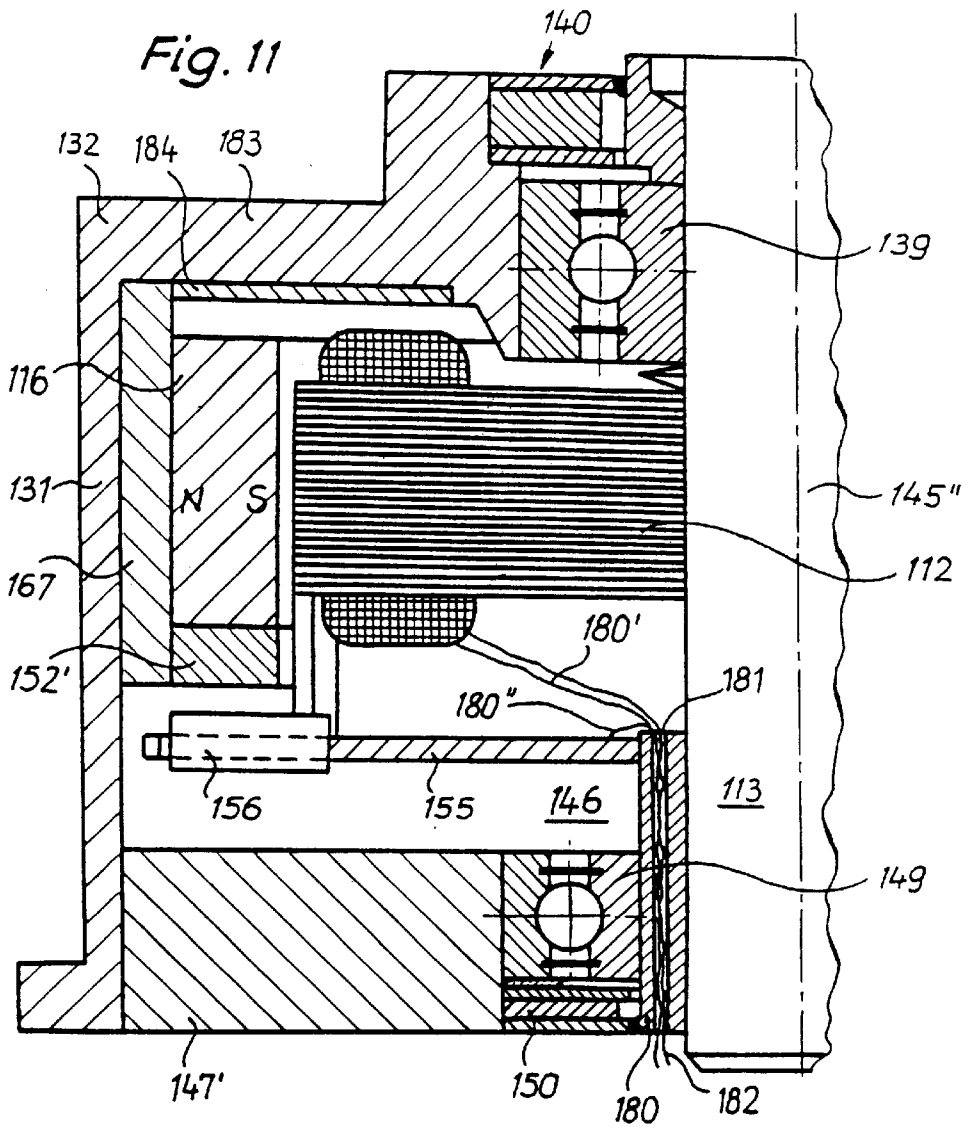

Fig. 10



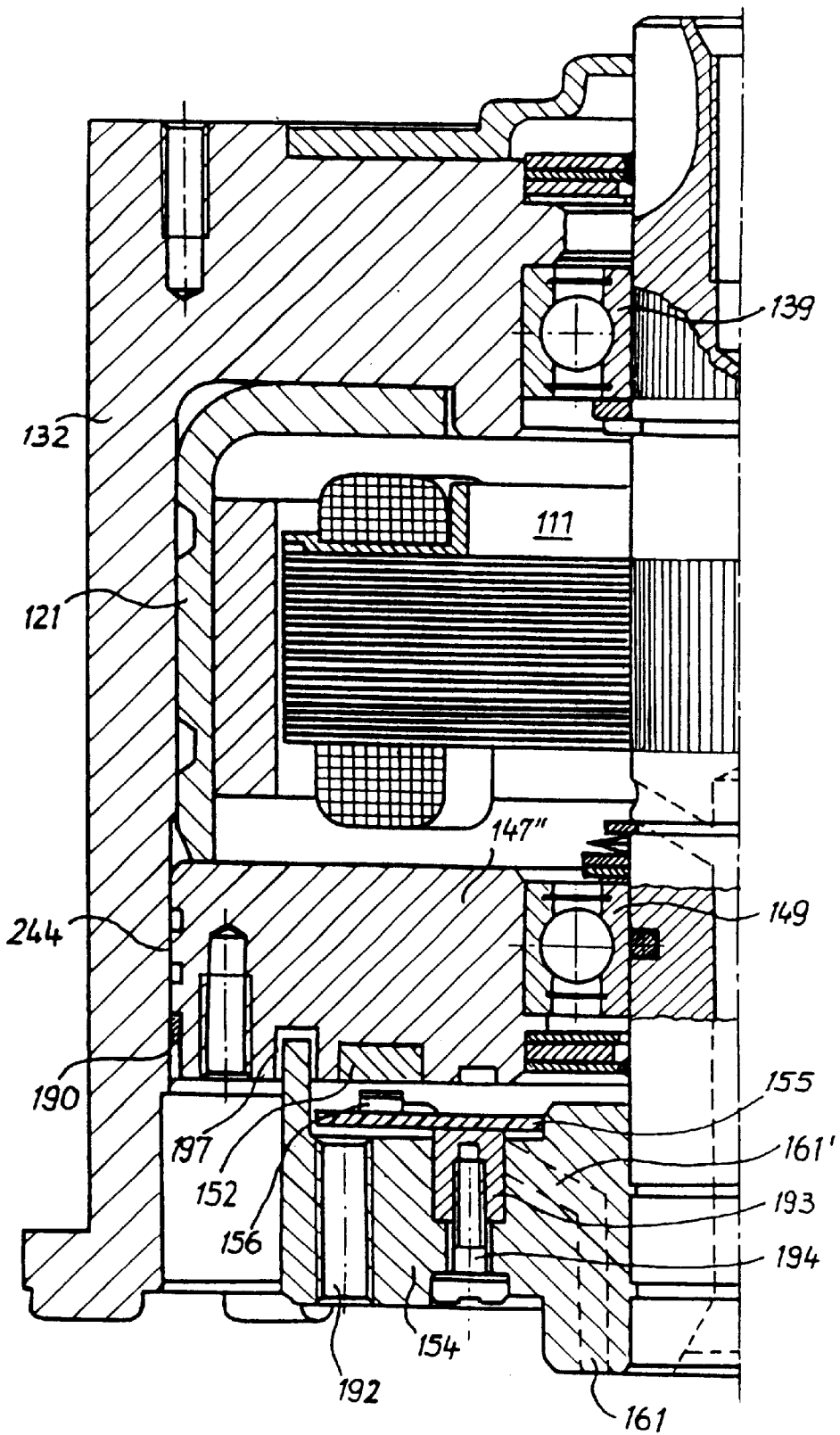

Fig. 13

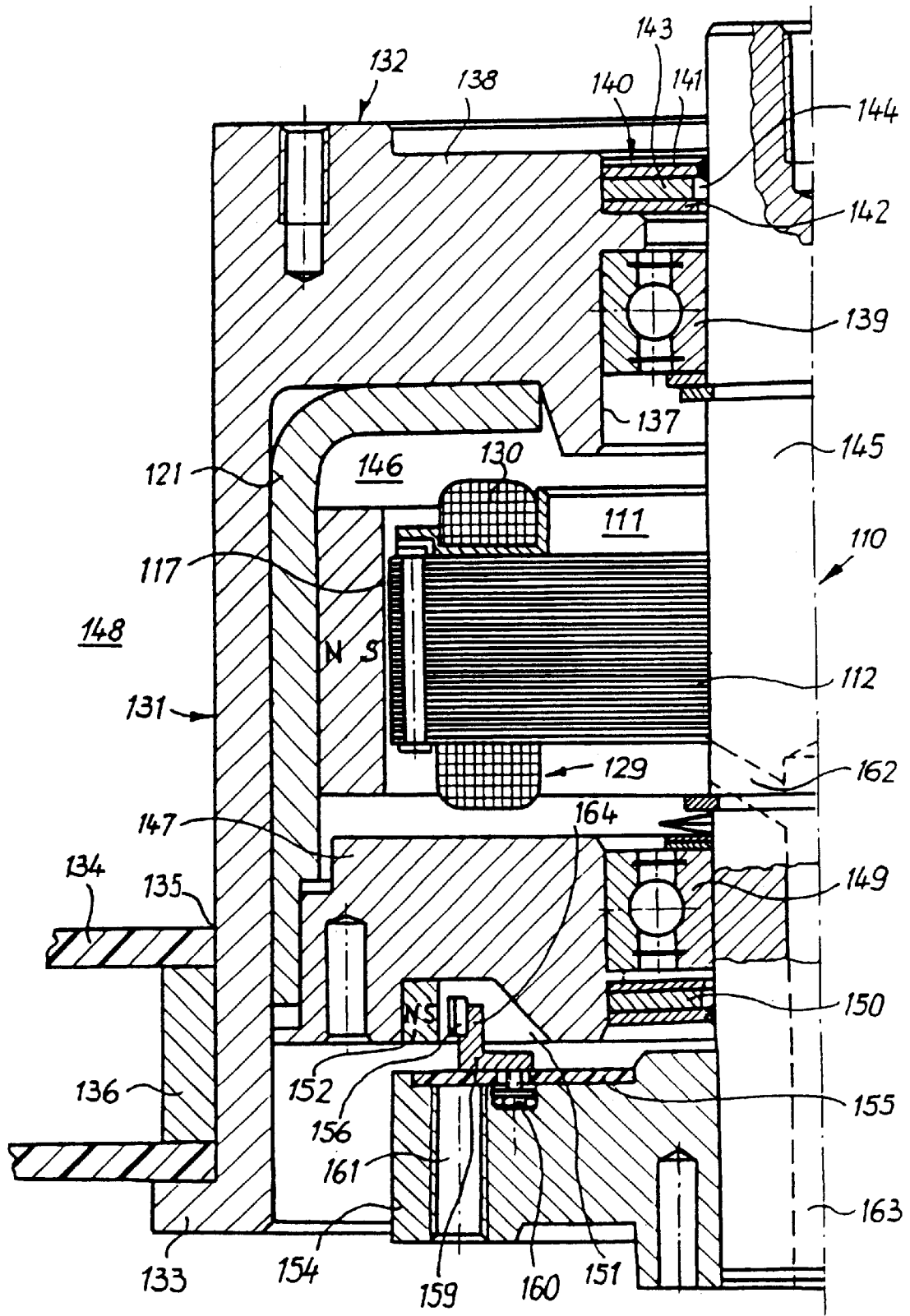

Fig. 14

DISK STORAGE DEVICE HAVING A THREE-PHASE BRUSHLESS DC UNDERHUB CONFIGURED SPINDLE MOTOR

Matter enclosed in heavy brackets [] appears in the original patent but forms no part of this reissue specification; matter printed in italics indicates the additions made by reissue.

CROSS-REFERENCE TO RELATED APPLICATIONS

A broadening reissue application for U.S. Pat. No. 5,173,814 was filed on Dec. 20, 1994 and assigned Ser. No. 08/360,226. On Mar. 4, 1997, a continuation of this application was filed and was assigned Ser. No. 08/819,099. On Jun. 9, 1999, five continuation applications from the 08/819,099 application were filed. On Nov. 17, 1999, a sixth continuation application from the 819,099 application was filed. All of these applications, as currently pending, are disclosed below:

- a. "Disk Storage Device Having A Sealed Bearing Tube," (Ser. No. 09/333,399), inventors Elsässer and von der Heide, filed Jun. 9, 1999;
- b. "Disk Storage Device Having A Radial Magnetic Yoke Feature," (Ser. No. 09/333,398), inventors Elsässer, von der Heide, and Müller, filed Jun. 9, 1999;
- c. "Disk Storage Device Having A Hub Sealing Member Feature," (Ser. No. 09/333,397), inventors Elsässer and von der Heide, filed Jun. 9, 1999;
- d. "Disk Storage Device Having An Underhub Spindle Motor," (Ser. No. 09/333,396), inventors Elsässer, von der Heide, and Müller, filed Jun. 9, 1999;
- e. "Disk Storage Device Having Three-Phase Brushless DC Spindle Motor," (Ser. No. 09/333,400), inventors Elsässer and von der Heide, filed Jun. 9, 1999; and
- f. "Disk Storage Device Having An Undercut Hub Member," (Ser. No. 09/441,504), inventors Elsässer and von der Heide, filed Nov. 17, 1999.

BACKGROUND OF THE INVENTION

This is a continuation of application Ser. No. 819,099, filed Mar. 4, 1997, now U.S. Pat. No. Re. 37,058, issued Feb. 20, 2001, which is a continuation of application Ser. No. 360,226, filed Dec. 20, 1994, now abandoned, which is a broadening reissue application of U.S. Pat. No. 5,173,814, issued Dec. 22, 1992 from application Ser. No. 653,100, filed Feb. 8, 1991, which is a continuation of application Ser. No. 07/402,917, filed Sep. 5, 1989, now U.S. Pat. No. 5,001,581, issued Mar. 19, 1991, which is a continuation of application Ser. No. 201,736, filed Jun. 2, 1988, [now] U.S. Pat. No. 4,894,738, issued Jan. 16, 1990, now U.S. Pat. No. Re. 35,792, issued May 12, 1998, which is a continuation-in-part of application Ser. No. 038,049, filed Apr. 14, 1987, now U.S. Pat. No. 4,843,500, issued Jun. 27, 1989, which is a continuation-in-part of application Ser. No. 767,671, filed Aug. 21, 1985, now U.S. Pat. No. 4,658,312, issued Apr. 14, 1987, which is a continuation of application Ser. No. 412,093, filed Aug. 27, 1982, now abandoned, which is a continuation-in part of application Ser. No. 326,559, filed Dec. 2, 1981, now U.S. Pat. No. 4,519,010, issued May 21, 1985, said application Ser. No. 412,093 also being a continuation-in-part of application Ser. No. 244,971, filed Mar. 18, 1981, now abandoned, said application Ser. No. 201,736 also being a continuation-in-part of application Ser. No. 32,954, filed Mar. 31, 1987, U.S. Pat. No. 4,779,165,

issued Oct. 18, 1988, now U.S. Pat. No. Re. 34,412, issued Oct. 19, 1993 which is a continuation of application Ser. No. 733,231, filed May 10, 1985, now abandoned, which is a continuation-in-part of the said application Ser. No. 412,093, said application Ser. No. 767,671 also being a continuation-in-part of Ser. No. 617,629, filed Jun. 6, 1984, now U.S. Pat. No. 4,556,829.

The invention relates to a disk storage drive for receiving at least one storage disk having a central opening, with an outer rotor type driving motor having a rotor casing mounted by means of a shaft in a bearing system so as to rotate relative to a stator and on which can be placed the storage disk for driving by the rotor casing, as described in U.S. patent application Ser. No. 353,584, now U.S. Pat. No. 4,438,542, issued Mar. 27, 1984.

The content of this patent is incorporated herein by reference to avoid unnecessary repetition. It relates to a storage drive for receiving at least one storage disk having a central opening. The driving motor extends coaxially at least partly through the central opening of the storage disk, and means are provided for connecting the storage disk and the driving motor rotor.

BRIEF SUMMARY OF THE INVENTION

One problem of the present invention is to further simplify the construction of a disk storage described in the aforementioned U.S. Pat. No. 4,438,542, while improving its operation. For example, the storage disk is to be reliably protected against undesired influencing by the magnetically active parts of the driving motor. In addition, a particularly space-saving and robust construction of the driving motor are to be achieved.

According to the invention, this first problem is solved in that at least the part of the rotor casing receiving the storage disk is made from a non-ferromagnetic material and carries the shaft directly or by means of a hub and in that a magnetic shield made from a ferromagnetic material in the form of a drawn can projects into the storage disk receiving part of the rotor casing and is connected thereto. The shielding surrounds the periphery of the magnetically active parts of the driving motor and also envelops the parts at one end. The shield has a central opening whose edge is directly radially adjacent the shaft or parts of the driving motor carrying or supporting the shaft. A rotor casing constructed in this way can be easily manufactured, and it effectively protects the magnetically sensitive storage disks, particularly magnetic hard storage disks, against magnetic stray flux emanating from the magnetically active parts of the driving motor. The shield is preferably in the form of a deep-drawn can, and the part of the rotor casing receiving the storage disk can be made from a lightweight metal by die casting.

If, in the manner described in the aforementioned U.S. Pat. No. 4,438,542, the driving motor is constructed as a brushless direct current motor with a permanent magnet rotor, then in accordance with a further development of the invention a printed circuit board with at least one rotary position detector and perhaps other electronic components for the control and regulation of the driving motor are mounted on the side of the stator remote from the closed end of the shielding can. This ensures that the rotary position detector and any further circuit components of the magnetic shielding arrangement do not interfere with the rotating parts.

Further advantageous developments of the invention also are disclosed, including features that contribute to a compact construction of the disk storage drive. In connection with

disk storage drives of the present type, high demands are made on the concentricity of the storage disks. It is therefore generally necessary to machine the storage disk receiving part or to work it in some other way so that it is dimensionally true. As a result of other features of the invention, the necessary machining is reduced to a relatively small part of the circumferential surface of the storage disk receiving part and a trouble-free engagement of a storage disk on the shoulder of the storage disk receiving part is permitted.

Other features of the invention provide a robust precision mounting support for utilizing the available axial overall length for maximizing the distance between the bearings; and permit particularly large distances between the bearings where the axial installation area between a mounting or assembly flange and the end of the storage disk receiving part is limited. Installation space is available on the other side of this flange. Still other features provide for alternative solutions leading to particularly small radial runouts of the rotor; ensure a space-saving housing of the circuit board; and for solutions where importance is attached to a particularly shallow construction.

In a further development of the invention, a disk storage drive of the type disclosed in U.S. Pat. No. 4,779,165, issued Oct. 18, 1988, *now U.S. Pat. No. Re. 34,412, issued Oct. 19, 1993*, is considered. Some such disk storage drives have stationary shafts and a sealed off internal space within the motor.

In the construction of such data storage disk drives with stationary shafts, problems also have arisen in the following areas:

- a) Achieving extremely high level of precision required for repeatable shaft runout;
- b) Improving the sealing of the clean chamber; and
- c) Achieving a and b within acceptable costs.

Yet another purpose of the present invention, therefore, is to provide a further development of the data storage disk drive of the above type having a stationary shaft by providing viable solutions for various combinations of the above problems, such as a and c; b and c; and a, b and c.

If the rotational position sensor device has several rotational position sensors, preferably of the type sensitive to magnetic fields, it is advantageous for these sensors to be supported on a common molded piece, especially if it is made by injection molding. The construction of the molded piece for the accommodation of several rotational position sensors in accordance with the invention simply ensures the precise mutual alignment of these sensors.

If required, the rotary position sensing arrangement can be mounted on a printed circuit board, together with any known type of commutation electronics. This printed circuit board can be supported on a fixed flange or bracket which is, in turn, connected to the shaft through which the connecting leads to the rotary position sensors may be brought out.

The control arrangement, which preferably takes the form of a control magnet can be mounted on the outside of a cover which seals off the space inside the motor. This cover may preferably serve as a bearing bracket as well. The control arrangement, however, also can be mounted on a part of the hub at a distance from the disk carrier stage outside the sealed internal space of the motor. A flange which serves to support the data storage disk or disks, may be connected to the remaining hub parts as one piece, or alternatively, this flange may form part of the cover which seals off the internal space of the motor.

In accordance with one variant of the present invention, at least the electric supply leads to the stator windings are brought out of the sealed internal space of the motor over a

bearing support ring. This arrangement obviates the need to provide passages in the shaft to accommodate the winding connections. In yet another alternative arrangement, the rotary position sensing arrangement, together with the commutation electronics, if necessary, can both be housed in the sealed internal space of the motor with their leads and connections being brought out over the bearing support ring. In any event, none of the above arrangements requires the provision of passages formed through the stationary shaft, thus avoiding the need to weaken the shaft or to perform additional machining operations in the manufacturing thereof.

The bearing support ring can be a prefabricated component provided with recesses for the passage of the electric leads and connections. Alternatively, the aforesaid connections can be potted inside the bearing support ring.

BRIEF DESCRIPTION OF THE DRAWINGS

The invention is described in greater detail hereinafter relative to non-limitative embodiments and the attached drawings, wherein:

FIG. 1 is a vertical partial sectional view through an embodiment of the invention along the line I—I of FIG. 2;

FIG. 2 is a plan view of the arrangement of FIG. 1;

FIG. 3 is a sectional view through another embodiment of the invention with an extended bearing tube;

FIG. 4 is a sectional view through a further embodiment of the invention;

FIG. 5 is a section through a disk storage drive motor, less the hub, according to the invention along line V—V of FIG. 6;

FIG. 6 is a section along line VI—VI of FIG. 5 and illustrating a rotational position sensor device located outside the sealed internal space of the motor;

FIG. 7 is a section similar to FIG. 6 of a modified embodiment of the invention;

FIG. 8 is a section similar to FIG. 6 of another modified embodiment of the invention;

FIG. 9 is a section similar to FIG. 6 of yet another modified embodiment of the invention;

FIG. 10 is a section similar to FIG. 6 of yet another embodiment of the invention;

FIG. 11 is a section through a disk storage drive according to the invention illustrating a rotational position sensor device located inside the sealed internal space of the motor with leads brought out through bearing support ring;

FIG. 12 is a partial section similar to but yet a variant of FIG. 7 of yet another embodiment of the invention having the rotational position sensor device located outside the sealed internal space of the motor;

FIG. 13 is a section illustrating a further variant of the embodiment shown in FIG. 6; and

FIG. 14 is a section illustrating yet another variant of the embodiment shown in FIG. 6.

DETAILED DESCRIPTION OF THE PREFERRED EMBODIMENTS

The disk storage drive illustrated in FIG. 1, having an extremely shallow construction, has a brushless direct current motor 45 having a rotor casing 47 fixed to and coaxial with a rotor shaft 46. A stator lamination 48, carrying a stator winding 49, is mounted on a bearing tube 50. The rotor shaft 46 is rotatably mounted within the bearing tube 50 by means of two bearings 52 and 53. These are kept axially spaced by

a pair of retaining rings **54**. A cup spring **55** is supported on the underside of the bearing **53** by a retaining ring **56** resting on the rotary shaft **46**, so that the bearings **52**, **53** are axially braced relative to one another. The bearings **52**, **53** are pressed into the bearing tube **50** at the time of assembly. Together with an assembly flange **24**, the bearing tube **50** forms a one-piece die casting.

The rotor casing **47** comprises a storage disk receiving part **25** and a shielding can **26**, which are joined together, for example, by riveting. The storage disk receiving part **25** is made from a non-ferromagnetic material, preferably lightweight metal. The rotor shaft **46** is pressed into a central opening of the storage disk receiving part **25**. As an alternative, the shaft can be cast into the receiving part.

The shielding can **26** is made from a ferromagnetic material and can in particular be constructed as a soft iron deep-drawn part. A plurality of permanent magnetic segments or a one-part permanent magnet **69** are fixed to the inner face of shielding can **26** radially facing the stator lamination **48**. The permanent magnet **69** preferably comprises a mixture of hard ferrite, for example, barium ferrite, and an elastic material. Thus, it is a so-called rubber magnet. The latter is trapezoidally or approximately trapezoidally radially magnetized via the pole pitch in a motor construction having a relatively small pole clearance. At the same time, the shielding can **26** forms the magnetic return path for magnet **69**. The shielding can **26** surrounds the magnetically active parts **48**, **49**, **69** of the driving motor **45** on the periphery thereof, as well as on one end thereof. The bottom **28** of shielding can **26** is adapted to the shape of the coil winding heads **27** of the stator winding **49** and contains a central opening **29**, whose edge is in the immediate radial vicinity of the circumferential surface of the bearing tube **50**. In this way, the shielding can effectively prevents the magnetic flux from straying towards the outside of the storage disk receiving part **25**.

The storage disk receiving part **25** has two stepped stages **74** and **75**, each of whose circumferential surfaces in the present embodiment carry a plurality of radially distributed and projecting bearing webs **79** or **80**. The outsides of bearing webs **79**, **80** are ground in a dimensionally true manner to accommodate the internal diameter of the hard storage disks to be placed on the receiving part **25**. The stepped stages **74**, **75** form shoulders **81**, **82** and are provided respectively with an annular recess **83** and **84** at the foot axially of bearing webs **79**, **80**. This structure ensures that storage disks mounted on the bearing webs **79**, **80**, and having either one of two opening diameters, will cleanly engage against either the shoulder **81** or **82**.

The assembly flange **24** is provided with a recess **85** in which is housed a printed circuit board **86**. This printed circuit board carries a rotary position detector, for example a Hall IC, as well as other circuit components for the control and regulation of the driving motor **45**. The Hall IC **63** extends up axially from the circuit board **86** to the immediate vicinity of the stator lamination **48**. The permanent magnet **69** projects axially over the stator lamination **48** in the direction of circuit board **86** until it partly overlaps the Hall IC **63**. In this way, the Hall IC **63** or, if desired, some other magnetic field-dependent semi-conductor component, determines the rotary position of the rotor of the driving motor **45**.

In the illustrated embodiment, the two bearings **52**, **53** are spaced approximately the same axial distance from the axial center of the permanent magnet **69** and the stator lamination **48**.

Disk storages are most usually operated in "clean chamber" environments to protect them against contaminants. By

means of the assembly flange **24**, the storage drive is arranged on a partition which separates the ultra-clean area for receiving the storage disks from the remainder of the interior of the equipment. Dirt particles, grease vapors and the like from bearing **52** and parts of the driving motor **45** are prevented from passing into the storage disk receiving area by labyrinth seals **90** and **91**. The labyrinth seal **90** is formed in the end of the bearing tube **50** away from the assembly flange **24** that projects into an annular slot **87** on the inside of the storage disk receiving part **25**, accompanied by the formation of sealing gaps. Similarly, for forming the labyrinth seal **91**, the end of the shield can **26** projects into the annular slot **88** of the assembly flange **24**. The labyrinth seals **90**, **91** are preferably dimensioned in the manner described in the aforementioned U.S. Pat. No. 4,438,542.

The embodiment of FIG. 3 differs from the arrangement according to FIGS. 1 and 2 in that storage disks having the same opening diameters are placed on bearing webs **79** of a storage disk receiving part **89**, which surrounds the majority of the axial dimension of the magnetic shielding can **26**. In other words, the magnetically active parts **48**, **49**, **69** of the driving motor **45** are partially located within the central opening of the storage disk. A bush-like hub **98** is pressed or cast into the storage disk receiving part **89**. The rotor shaft **46** is then pressed into the hub **98**. The edge of the central opening **29** in the bottom **28** of the shielding can **26** extends up to the portion **99** of the receiving part **89** which received the hub **98**.

The bearing tube **50** projects in the axial direction on the side of the assembly flange **100** remote from the stator lamination **48**. As a result, a particularly large axial spacing between the two bearings **52**, **53** can be achieved. Axially, bearing **52** is in the vicinity of the axial center of the permanent magnet **69** and of the stator lamination **48**. The axial spacing between bearings **52** and **53** is equal to or larger than double the bearing external diameter. To prevent electrical charging of the rotor which in operation rotates at high speed and which would disturb the operational reliability of the disk storage device, the rotor shaft **46** is electrically conductively connected to the equipment chassis by means of a bearing ball **78** and a spring contact (not shown). The printed circuit board **101**, carrying the rotary position detector **63** and the other electronic components, is supported on the end of a spacer ring **102** facing an assembly flange **100** and is located between the flange and the stator lamination **48**. An annular slot **103** is formed in assembly flange **100** and is aligned with the annular circuit board **101**. The annular slot **103** provides space for receiving the wire ends and soldered connections projecting from the underside of the circuit board **101**.

FIG. 4 shows an embodiment in which a storage disk receiving part **105** is axially extended in order to be able to house a larger number of storage disks than in the arrangement of FIG. 3. The bearing tube **50** is correspondingly axially extended in order to be able to use the existing installation space with a view to a maximum axial spacing between the bearings **52** and **53**. The end of the bearing tube **50**, remote from an assembly flange **106**, embraces the hub **98** connecting the receiving part **105** and the shaft **46**, accompanied by the formation of a labyrinth seal **107**. The edge of the central opening **29** of shielding can **26** extends up close to the outside of the bearing tube **50**. The free end of the shielding can **26** engages a recess **108** in the assembly flange **106**. As a result, a further labyrinth seal **109** is formed. This embodiment otherwise corresponds to the structures already described herein.

In FIGS. 5 and 6, a brushless drive motor, designated as **110** has a stator **111** with a stator lamination stack **112**. The

stator lamination stack **112** is arranged radially and symmetrically with respect to a central axis of rotation **113** and forms six stator poles **114A** to **114F** in an essentially T-shaped configuration as seen from above in accordance with FIG. 5, which poles are positioned at regular angular intervals of 60°. Instead of one lamination stack, for example, a sintered iron core can also be provided. Pole shoes **115A** to **115F**, together with a permanent magnetic rotor magnet **116** define an essentially cylindrical air gap **117**. The rotor magnet **116** is radially magnetized in four poles around its periphery as indicated in FIG. 5; that is to say, it has four sections **118A** to **118D**, and, on the internal side of the annular rotor magnet **116** toward the air gap **117** there are positioned, in alternating sequence, two magnetic north poles **119** and two magnetic south poles **120**. The poles **119**, **120** have, in the example depicted, a width of substantially 180°-el (corresponding to 90° mechanical). Thus, in the circumferential direction of the air gap **117**, an approximately rectangular or trapezoidal magnetization is obtained. The rotor magnet **116** is mounted, typically by bonding, in an outer rotor casing or bell **121** of soft magnetic material, preferably steel, which serves both as a magnetic return path and as a magnetic shield. The casing **121** and the magnet **116** together form an external rotor **122**. The rotor magnet **116** can include in particular a rubberized magnetic unit, or a plastic-bound magnet. Instead of a single-piece magnetic ring, curved magnetic segments can also be bonded or otherwise attached in the casing **121**. Magnetic materials made from synthetic bonding compounds, a mixture of hard ferrite and elastomers, ceramic magnetic materials or samarium cobalt are all particularly suitable as materials for the magnetic ring or segments.

The stator poles **114A** to **114F** abut a total of six stator slots **123A** to **123F**. A three-phase stator winding is inserted into these slots. Each of the three phases comprises two 1200°-el fractional pitch windings or coils **124**, **125**; **126**, **127**; and **128**, **129**, each of which is wound around one of the stator poles **114A** to **114F**. Both of the coils of each phase, which are connected in series, lie, as depicted in FIG. 5, in a diametrically opposed manner and are preferably bifilar wound. As can be seen from the schematic depiction in FIG. 5, any overlapping between the coils **124** to **129** is avoided. This arrangement allows the end turns of the windings **130** (FIG. 6) to be kept as short as possible. In this embodiment of the present invention, optimal filling of the stator slots **123A**–**123F** by the windings is achieved. Fasteners are generally not required to close the slot openings.

A hub **132**, not depicted in FIG. 5, is provided with a cylindrical disk mounting section **131** and preferably is made of a light metal, especially aluminum or an aluminum alloy. It is mounted on the outer rotor casing **121**. One or more storage disks **134**, preferably magnetic or optical fixed storage disks, are provided on the disk mounting section **131**, whereby the disk mounting section **131** extends through the conventional central aperture **135** of the storage disks. The lowest storage disk in FIG. 6 is located on a flange **133** of the hub **132** projecting radially outwardly. The data storage disks **134** can be maintained at an axial distance from each other by suitable spacers **136** and are secured to the hub **133** by means of a tightening device, not depicted, of a known type. In the embodiment shown in FIG. 6, the stator **111**, the stator stack **112** and the stator winding (coils **124** through **129**) as well as the rotor magnet **116** and the outer rotor casing **121** forming the iron shield, are all completely encompassed within the space occupied by the storage disk stage **131** on the hub **132**.

In a central aperture **137** of a frontal wall **138** of the hub **132**, which is relatively heavy for reasons of stability, are a

ball bearing **139** and a magnetic fluid seal **140** on the side of the support which is axially oriented away from the drive motor **110**. The seal **140** consists of two annular pole pieces **141**, **142**, a permanent magnet ring **143** located between both these pole pieces, and a magnetic fluid (not shown), which is inserted into an annular gap **144** between the magnetic ring **143** and a stationary shaft **145**. Seals of this type are known under the designation of "Ferrofluidic Seal". An internal space **146** is located within the motor and is sealed on the side of the space oriented away from the frontal wall **138** by means of a motor cover **147**, which is inserted into the outer rotor casing **121** and the hub **132**, by means, for example, of adhesion. The internal space **146** includes the internal parts such as the stator **111** and permanent magnet **116** as well as bearings **139** and **149**. The motor cover **147** abuts with its cylindrical outer edge **247** the lower edge of the rotor casing **121**. This allows a particularly easy assembling of the cover **147** within the hub **132**. For sealing purposes, adhesive material **190** is placed in a circumferential groove **191** between the cover **147** and the hub **132**.

The motor cover **147** is supported on the shaft **145** by means of an additional ball bearing **149**. On the side of the ball bearing **149** away from the drive motor **110**, there is a magnetic fluid seal **150**, which has a construction corresponding to the seal **140**. The seals **140**, **150** ensure an effective sealing of the motor internal space **146**, including the bearings **139**, **149**, relative to a clean chamber **148** which accommodates the storage disks **134**.

The motor cover **147** is provided on the frontal side facing away from the drive motor **110** with an annular groove **151** receiving a control magnet ring **152**. The control magnet ring **152** has four sections of alternating circumferential magnetization corresponding to the rotor magnets **116**, which run in sequence in the circumferential direction and extend over 90°, so that alternating north and south poles, aligned with poles **119**, **120** in the circumferential direction, are provided on the bottom side of the control magnet ring **152**.

A stationary flange **154** is disposed on the lower end of the shaft **145** in FIG. 6. The flange **154** is provided with threaded bores **192** for receiving fastening screws by which the disk storage drive may be connected to the disk drive frame, for example, over a wall delimiting the clean chamber **148**, or the like. The flange **154** supports a printed circuit board **155** on its frontal side relative to the motor cover **147**. Three rotational position sensors **156**, **157**, **158** are mounted on the printed circuit board **155**. In the embodiment shown, these magnetic field sensors may be Hall generators, Hall-IC's, magnetically controlled photocells, magnetic diodes, or the like, which interact with the control magnet ring **152**. The rotational position sensors **156**, **157**, **158** are suitably positioned in the circumferential direction with regard to the coils **124** to **129** so that the changes of the sensor switching conditions essentially coincide with the zero passages of current in the correspondingly positioned coils. This is attained, in accordance with the embodiment shown in FIG. 5, through the fact that the rotational position sensors are displaced by 15-mech with respect to the center of the apertures of the stator slots **123A** to **123F**. The rotational position sensors **156**, **157**, **158** may be supported by a common molded part **159** (see, for example, FIG. 14), preferably a plastic injection molded part. By using a common molded part **159** as the support for the rotational position sensors, their relative positioning with respect to one another can be maintained and reproduced in a particularly precise manner. The printed circuit board **155** is fixed

to a ring 193 and is tightly pulled against the flange 154 by screws 194 screwed into a ring 193. An upwardly projecting outer rim 195 of flange 154 defines a hollow cylinder extending into an annular groove 196 provided in the bottom side of the flange 154. Thereby a labyrinth gap 197 is formed which provides for additional sealing between the stationary flange 154 and the rotary motor cover 147.

The connections of the rotational position sensors 156, 157, 158 and/or commutational electronics likewise positioned on the printed circuit board are conducted through one or more apertures 161 of the flange 154 which open into peripheral cutouts of the ring 193. The connections of the stator winding coils 124 to 129 of the drive motor 110 are, on the other hand, conducted outwardly through bores 162, 163 of the stationary shaft 145 out of the internal space of the disk storage drive, which is sealed off by means of the magnetic fluid seals 140, 150. The bores 162, 163 can be dimensioned relatively narrowly, because they only have to accommodate the connections of the stator winding but not the connections of the rotational position sensors and/or the commutation electronics (not shown). Furthermore, the rotational position sensors 156 to 158 located outside of the sealed space 146 can be closely adjusted. An excessive weakening of the shaft 145 is thereby avoided.

In a further modified embodiment shown in FIG. 7, the rotor magnet 116 is located directly within the hub 132', which itself forms the magnetic shield, and is made of magnetically conductive material, preferably soft iron. The control magnet ring 152' is located on the frontal side of the flange 133 facing away from the disk mounting section 131 of the hub 132', and alternately magnetized in the axial direction. In this embodiment, the rotational position sensors 156, 157, 158 are axially opposed to the control magnet ring 152'. The magnetic fluid seal 150 ensures, together with a labyrinth seal 165 which replaces the magnetic fluid seal 140 of the embodiment in FIG. 6, the sealing of the internal space 146, including the bearings 139, 149 relative to the clean chamber 148. The connections of the stator winding 166 are conducted through the bores 162, 163 of the stationary shaft 145. It should be understood that, even in this embodiment, the rotational position sensors 156, 157, 158, can, if desired, be accommodated by a common support corresponding to the molded part 159 (FIG. 14), which support is attached to the printed circuit board 155.

If it is desirable to manufacture the hub 132' from magnetically non-conducting, or poorly conducting, materials, such as light metal or alloy, a separate iron shield can be provided. This can be seen in the embodiment in FIG. 8. There, the rotor magnet 116 is accommodated in an iron shielding ring 167. The flange 169 supporting the storage disk 134 forms a part, separated from the hub 132', of the cover 170 which accommodates the ball bearing 149. The hub 132 and the cover 170 are closely connected with one another, so that the axial end section of the hub 132, which extends towards the cover 170, engages in an annular groove 171 of the cover 170.

In both embodiments of FIGS. 9 and 10, the control magnet ring 152' is located in a groove 173 of a bearing support ring 174 on the end of the hub 132. The hub 132 itself forms the magnetic shield, and is accordingly made from conductive material, particularly steel. The control magnet ring 152' interacts, as shown in FIG. 7, with the rotational position sensors 156, 157, 158, which are not shown in FIGS. 9 and 10. In the embodiment in FIG. 9, the internal space 146 is sealed off by means of the magnetic fluid seals 140, 150, but in the embodiment in FIG. 10, labyrinth seals 175 are provided in their place. The embodi-

ment of FIG. 10 further differs from that of FIG. 9 by the stationary shaft 145' in the area where it supports the stator lamination stack 112, and the area directly adjoining the same axially, being axially thickened so that the shaft 145 forms shoulders 176, on which the ball bearings 139, 149 are supported.

In the embodiments shown in FIGS. 8, 9, and 10, the connections of the stator winding are, in a manner preferably corresponding to the embodiments shown in FIGS. 6 and 7, brought out externally through recesses of the shafts 145 and 145'.

FIG. 11 depicts an embodiment similar to that of FIG. 11 of copending U.S. Ser. No. 733,231, in which a soft magnetic yoke ring 167 is inserted in the hub 132, the latter forming a disk mounting section 132 and preferably being made of light metal. Both the rotor magnet 116 and the control magnet 152' are accommodated in the inner circumference of the yoke ring 167. In this embodiment, the printed circuit board 155 together with the rotational position sensors 156, 157, 158 are located within the space 146 sealed by the magnetic fluid seals 140, 150. The circuit board 155 may be suspended from the stator lamination stack 112 by supports 178. A bearing support ring 180 is provided for bringing outwardly the connections 180' of the stator winding as well as the connections 180 of the rotational position sensors 156, 157, 158 and/or of the electronic commutating means which likewise may be mounted on the printed circuit board 155. The support ring 180 is made of the soft magnetic material, preferably ferromagnetic metal, and surrounds and is firmly fixed to shaft 145. The ball bearing 149 and the magnetic fluid seal 150 are disposed between the cover 147' and the support ring 180. At least one and preferably a plurality of axially extending apertures 181 are provided in the support ring 180 for receiving the aforementioned connections. After introduction of the connections therein, which together are indicated at 182, the apertures 181 are sealed, e.g. by a potting compound or a mastic. This embodiment completely avoids bores in the stationary shaft 145 and therefore the solid shaft retains its full strength. The provision of a bearing support ring 180 provides for a particularly small eccentricity or run-out of the rotating members. A soft magnetic shield ring 184 is provided on the inside of the frontal wall 183 of the hub 132.

The embodiment of FIG. 12 corresponds to that of FIG. 7 with the exception that a connection 166 of the stator winding extends through a bearing support ring 185 rather than through the bores in the stationary shaft 145. The ring 185 surrounds the lower portion of the shaft 145. The ball bearing 149 and magnetic fluid seal 150 are disposed in the annular space between the support ring 185 and the ferromagnetic ring 153, which is inserted into hub 132'.

In an embodiment where the rotary position sensors are located externally, the winding leads can also be brought out through an inner bearing support ring encompassing the bearing 149, corresponding to the support ring 180 in FIG. 11. Furthermore, in an embodiment provided with an inboard rotary position sensing arrangement similar to that shown in FIG. 11, a bearing support ring 185 according to FIG. 12 mounted on the stationary shaft 145 and supporting the ball bearing 149 on the inside can be used to bring the connections out to the exterior.

The metal support ring 185 according to FIG. 12 ensures that the rotating parts will display particularly limited runout. The magnetic field of the magnetic liquid seal 150 can be contained in either the ferromagnetic support ring 185 or the ferromagnetic ring 153.

Instead of providing the bearing support rings **180** or **185** with apertures through which the connections can be brought out, the connections can also be potted in the bearing support ring directly.

FIG. 13 shows an embodiment similar to that shown in FIG. 6, of which it is only a further development in many respects.

A particular feature of this further embodiment is the provision of a flat air gap between rotational position indicator or magnetic control ring **152** and the rotational position sensor **156**. The printed circuit board **155** is firmly fastened to a stationary flange part **154** with the screw **194**. The outside edge of this flange **154** engages in a disk-shaped ring member **147**, which may be the motor cover **147** (FIG. 6) in an axial direction like a hollow cylinder, so as to provide a labyrinth gap **197** acting as an additional seal between the stationary flange **154** and the disk-shaped ring member **147**. The lower edge of the soft iron outer rotor casing **121** bears on the rotating ring member **147** whose cylindrical outer edge **244** is more easily inserted in the hub body **132** than the arrangement shown in FIG. 6. A mastic **190** is used as the sealant in a peripheral groove between the ring member **147** and the hub **132**.

From the user's point of view, the entire motor assembly is fastened by use of appropriate fasteners in the hole **192**. The connecting leads from the printed circuit board **155** to the rotational position sensor **156** are brought out through the passage or bore **161** shown with the disked lines, which extends outwardly from an oblique channel **161'** until it terminates in the peripheral apertures in the ring **193** which is brought to bear on the flange **154** by a screw **194**.

The ring member **147** corresponds to the elements described in the various embodiments and examples as the covers **170**, **147**, **147'** and the rings **53**, **74**. Preferably, therefore, only **2** parts are needed to completely enclose the inner space **146** of the motor other than the stationary shaft **145** and the bearings **139**, **149**; namely, the rotor casing **132** and the disk-shaped ring member **147**.

FIG. 10 shows a ring **175**, somewhat L-shaped in section, which rotates together with the outer rotor of the hub, whereby the ring **175** encompasses an inner, essentially complementary mating part **165**, so that the longer leg of the outside part **175** is only separated from the stationary shaft by a narrow gap **275**. In combination with the inside mating part **165**, this arrangement provides an effective labyrinth seal. This is referenced item **175'** in the lower part of FIG. 10, where the basic L-shaped section of the seal is indicated by a solid line and the complementary mating section is referenced **165'**. The effectiveness of the labyrinth seal can be enhanced if a projection **175** on the part **175** is provided to project into a recess **165'**, of the complementary part **165'**. The arrangement may be seen also in the upper part of the drawing. In this way, the need to use a substantially more costly magnetic liquid seal of the type shown in FIG. 9 as items **140** and **150**, can be avoided. Of course, the incorporation of a labyrinth seal of this type provided with these two interlocking L-shaped leg profiles has an independent significance in connection with data storage disk drives and is not required by the other design features of this motor. As already mentioned, the additional recesses **165'** provide further enhancement of the sealing action of the labyrinth seals. Elements of this type are manufactured as large volume extrusions or deep drawn die pressings and their cost hardly bears comparison with that of magnetic liquid seals. They provide a good low-cost means of the sealing of the clean chamber, because they can be installed at the points of

access to the space inside the motor, either in an axial direction or otherwise.

FIG. 14 is a variant of FIG. 6 primarily in the provision of the groove **151** in the motor cover **147** which receives the magnet ring **152** and allows the rotational position sensor **156** to face the magnet ring across a cylindrical air gap vis-a-vis a planar gap in the embodiment shown in FIG. 6.

This invention is not restricted to the use of magnetic field-sensitive rotational position sensors. It can also be used, for example, with optical sensors.

Although the invention has been described in connection with a preferred embodiment and certain alternatives, other alternatives, modifications, and variations may be apparent to those skilled in the art in view of the foregoing description. Accordingly, it is intended to embrace all such alternatives, modifications, and variations as fall within the spirit and scope of the appended claims.

What is claimed is:

[1. A disk memory drive comprising: a brushless drive motor having an internal space defined therein and a stator including winding means defining magnetically active parts of the drive motor and having a given axial extension, the motor having an outer rotor with an inner circumference, an outer circumference and an open end coaxially encircling the stator and a substantially cylindrical air gap defined between the stator and the rotor, the rotor including a separate non ferromagnetic hub and a soft iron ring element interiorly of said hub and radially located means forming a permanent magnet interiorly of said ring having a predetermined axial extension fixedly connected therewith for magnetic interaction with said winding means; a disk mounting section provided on the outside of said hub for accommodating at least one storage disk for location in a clean chamber surrounding said rotor when the drive motor is mounted for operation, the disk mounting section on the hub along its axial length being adapted to extend through a central aperture of the storage disk, the winding means and the magnet means interacting therewith being disposed for at least half of the axial extension thereof within a space surrounded by the disk mounting section of the hub; and first and second axially separated bearing means having inner and outer races on a shaft rotatably mounting the rotor and the hub on the shaft, the motor also including rotating means interacting with stationary means for determining the rotational position of the rotor, the internal space of said motor, which includes the internal portions thereof with the bearing means, being sealed off against the clean chamber when the drive motor is mounted for operation, a disk-shaped ring member being located with precision at the open end of the rotor between the inner circumference of the rotor and the outer race of one of the axially separated bearing means, and means stationary containing leads establishing electrical connection between the internal space and the outside of the motor.]

[2. A disk memory drive according to claim 1, wherein said rotating means interacting with said stationary means comprises rotational position indicator means which includes permanent magnet poles disposed on the disk-shaped ring member for rotation therewith and wherein the rotational position sensor means is sensitive to magnetic fields and interacts with the permanent magnet poles.]

[3. A disk memory drive according to claim 2, wherein the shaft is a stationary shaft.]

[4. A disk memory drive according to claim 3 wherein the rotational position sensor means is mounted on a printed circuit board opposite the disk-shaped member ring.]

[5. A disk memory drive according to claim 4, further including electronic commutation devices for the electro-

13

magnetization of the stator also being mounted on the printed circuit board.]

[6. A disk memory drive according to claim 4, wherein the printed circuit board is supported on a flange fixed to the stationary shaft.]

[7. A disk memory drive according to claim 3, further including a magnetic shield means at least circumferentially surrounding the stator for shielding a clean chamber containing the disk from the magnetic flux of the stator and wherein the stationary shaft is of constant diameter and the outer rotor includes a bell-shaped housing with a substantially closed end and a substantially open end, the stator together with the magnetic shield being firmly mounted to the stationary shaft, the inner race of each bearing being firmly mounted on the stationary shaft on either axial side of the stator, the upper bearing being positioned inwardly adjacent of the closed end of the bell-shaped outer rotor, and the lower bearing being positioned adjacent the open end of the bell-shaped outer rotor.]

[8. A disk memory drive according to claim 2, wherein the internal space of the motor is sealed by means of a cover located at the open end of the outer rotor, the cover also serving as a bearing mounting flange, and the rotational position indicator means being mounted on the outside of the motor cover with respect to the sealed inner space of the motor.]

[9. A disk memory drive according to claim 2, wherein the outer rotor includes an outer rotor casing of ferromagnetic material, the outer rotor serving also as the hub, the rotational position indicator being mounted on a lower part of the hub outside the sealed inner space of the motor.]

[10. A disk memory drive according to claim 2, further comprising a bearing mounting flange having projections in the actual axial direction that project into the disk-shaped ring member, and a labyrinth seal located between the projections and the ring member formed by a combination of cylindrical and radially flat gaps having only dimensions of normal clearances between moving parts.]

[11. A disk memory drive according to claim 10, wherein the projections on the bearing mounting flange are rectangular in section and extend axially.]

[12. A disk memory drive according to claim 10, wherein the ring member on which part of the bearing race is mounted is substantially flush in the axial direction with the mounting flange, the ring member being inserted in the outer rotor casing that forms the hub.]

[13. A disk memory drive having a brushless drive motor, comprising a stator having a predetermined axial extension, a coaxially positioned outer rotor encircling the stator and defining therebetween a substantially cylindrical air gap, the rotor having an inner circumference and an outer circumference and a predetermined axial extension, a cylindrically shaped permanent magnet having a predetermined axial extension disposed adjacent the air gap on the inner circumference of the rotor to rotate therewith and magnetically interact with the stator, a ferromagnetic hub on the outer circumference of the rotor firmly fixed to the motor magnet, the hub radially surrounding the predetermined axial extension of said permanent magnet and being provided on its outer circumference with a disk mounting section which can extend through the central opening in a storage disk to mount at least one storage disk thereon, a shaft having first and second axially separated bearing means mounted thereon rotatably mounting the rotor with hub on the shaft, and seals located axially outside of the axial extension of the first and second bearing means for sealing the space therebetween.]

14

[14. A disk memory drive according to claim 13, wherein the shaft is a stationary shaft.]

[15. A disk memory drive according to claim 14, wherein the seals are magnetic liquid seals.]

[16. A disk memory drive according to claim 14, wherein the seals are labyrinth seals.]

[17. A disk memory drive according to claim 14, wherein the stationary shaft projects axially externally of the upper and lower seals.]

[18. A disk memory drive according to claim 14, wherein the labyrinth seal is formed of a member having a substantially L-shaped cross section, being mounted on and extending radially from the stationary shaft, the short leg of the L-shaped member extending axially outwardly.]

[19. A disk memory drive according to claim 16, further including a ring member of L-shaped cross section being provided on the rotor and being opposite and complementary to the stationary mounted L-shaped member, the longer leg of the L-shaped member on the rotor extending inwardly toward the stationary shaft with only a clearance dimension separating the two parts.]

[20. A disk memory drive according to claim 16, wherein the stationary L-shaped member lies inboard axially and is substantially encompassed by the rotating L-shaped ring, a flat radial labyrinth gap being formed radially between the respective short legs of the L-shaped members.]

21. A disk storage device, comprising in combination:
a housing for providing an environment that is not maintained substantially contaminant free;

at least one rotatable storage disk that is provided in said environment for rotation about an axis, said at least one disk having a central opening;

at least one data head that is provided in said environment and that allows information to be read from said at least one storage disk;

a brushless DC motor for rotating said at least one storage disk about said axis, said brushless DC motor including a stator concentric with said axis, a stator winding disposed on said stator that has at least first, second, and third phase windings that are Y connected, each of said phase windings including at least two non-overlapping stator coils, said brushless DC motor further including a shaft aligned on said axis, at least one bearing affixed to said shaft, and a rotor that is mounted for rotation about said axis relative to said stator, said rotor having a permanent magnetic ring that has at least four permanent magnets of alternating polarity and that is mounted on a magnetically conductive member in a manner such that a generally cylindrical air gap is defined between adjacent surfaces of said stator and said permanent magnetic ring;

a circuit that generates first, second, and third control signals that are offset by approximately 120° electrical from one to the next and that are generally representative of the position of said rotor with respect to said stator, each one of said control signals being at a first potential during an interval of approximately 180° electrical and being at a second potential during a next following interval of approximately 180° electrical;

said circuit applying first, second, and third drive voltages to said first, second, and third phase windings to thereby supply current to the coils in each one of said phase windings in a cyclical sequence as a function of said first, second, and third control signals to cause said rotor to rotate about said axis;

wherein first, second, and third induced voltages are induced in said first, second, and third phase windings

by the rotation of said permanent magnetic ring with respect to said phase windings, each one of said induced voltages being offset by approximately 120° electrical from one to the next and, in passing through zero, being alternatively positive for an interval of at most 180° electrical and negative for an interval of at most 180° electrical, the sum of said first, second, and third induced voltages being approximately equal to zero for every relative position between said rotor and said stator;

wherein the changes of state of said first, second, and third control signals are in a fixed relationship with the zero-crossovers of said first, second, and third induced voltages so that said circuit generates said first, second, and third drive voltages without changing the approximate duration of said first, second, and third control signals;

wherein said circuit causes the duration of said first, second, and third drive voltages to be approximately equal to the duration of said first, second, and third control signals so that overlapping currents are generated in said three-phase winding thereby allowing said motor to provide generally smoother torque; and wherein said brushless DC motor is mounted in said environment so that the space of said environment that is occupied by said at least one storage disk is axially separated from the space of said environment that is occupied by said permanent magnetic ring in a direction along said axis.

22. The disk storage device of claim 21 wherein said central opening is smaller than at least one of the distances specified in a group consisting of: the inner diameter of said permanent magnetic ring, the outer diameter of said permanent magnetic ring, the inner diameter of said magnetically conductive member, and the outer diameter of said magnetically conductive member.

23. The disk storage device of claim 21 wherein said magnetically conductive member provides at least a portion of a magnetic return path for said permanent magnetic ring.

24. The disk storage device of claim 21 wherein said shaft is rotatable about said axis.

25. The disk storage device of claim 21 wherein said rotor comprises an external rotor.

26. The disk storage device of claim 21 wherein said permanent magnetic ring coaxially surrounds the Portion of said stator that forms said generally cylindrical air gap.

27. The disk storage device of claim 21 further comprising at least two rotor position detectors that are mounted stationary with respect to said stator.

28. The disk storage device of claim 27 wherein said rotor position detectors comprise Hall effect sensors.

29. The disk storage device of claim 28 wherein said Hall sensors are positioned with respect to said stator to cause the changes of state of said first, second, and third control signals to substantially coincide with the zero-crossovers of said first, second, and third induced voltages.

30. The disk storage device of claim 29 wherein at least one of said control signals changes state at approximately the same time as the zero-crossover of a corresponding one of said induced voltages.

31. The disk storage device of claim 21 wherein the changes of state of said first, second, and third control signals substantially coincide with the zero-crossovers of said first, second, and third induced voltages.

32. The disk storage device of claim 31 wherein at least one of said control signals changes state at approximately the same time as the zero-crossover a corresponding one of said induced voltages.

33. The disk storage device of claim 21 wherein at least one of said control signals changes state at approximately the same time as the zero-crossover of a corresponding one of said induced voltages.

34. The disk storage device of claim 21 further comprising a hub member for supporting said at least one disk said hub member having a cylindrical portion that extends through the central opening of said at least one storage disk.

35. The disk storage device of claim 34 wherein said hub member is contiguous with a portion of said rotor.

* * * * *

UNITED STATES PATENT AND TRADEMARK OFFICE
CERTIFICATE OF CORRECTION

PATENT NO. : RE 38,179 E
DATED : July 8, 2003
INVENTOR(S) : Elasser et al.

Page 1 of 1

It is certified that error appears in the above-identified patent and that said Letters Patent is hereby corrected as shown below:

Column 3,

Line 55, please replace "magnet can be" with -- magnet device, can be --

Column 16,

Line 6, please replace "the Portion of," with -- the portion of --

Line 34, please replace "one disk said hub," with -- one disk, said hub --

Signed and Sealed this

Second Day of December, 2003

A handwritten signature in black ink, appearing to read "James E. Rogan", with a long horizontal flourish underneath.

JAMES E. ROGAN
Director of the United States Patent and Trademark Office