

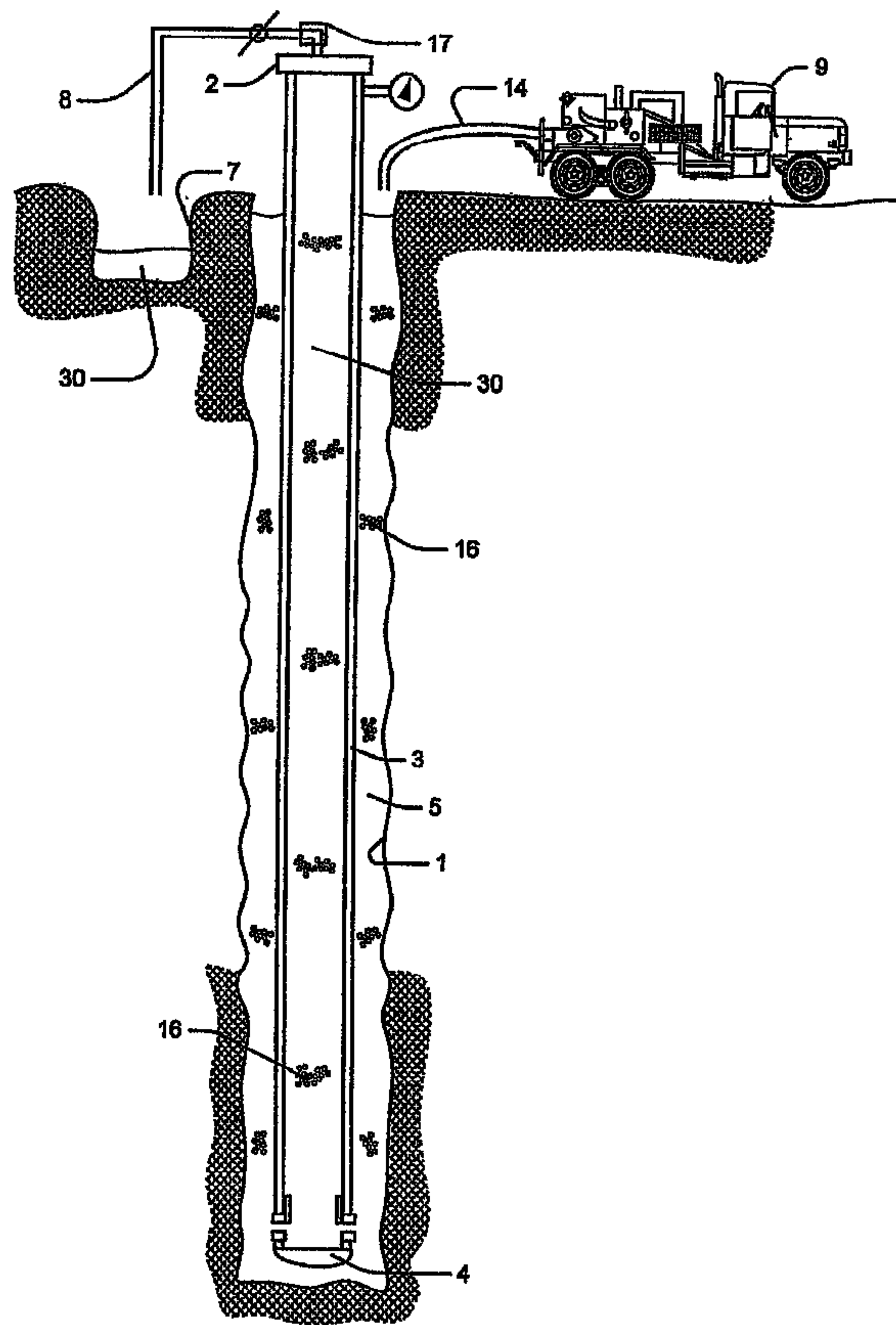

(86) Date de dépôt PCT/PCT Filing Date: 2005/10/06
 (87) Date publication PCT/PCT Publication Date: 2006/05/04
 (45) Date de délivrance/Issue Date: 2009/12/22
 (85) Entrée phase nationale/National Entry: 2007/04/23
 (86) N° demande PCT/PCT Application No.: GB 2005/003854
 (87) N° publication PCT/PCT Publication No.: 2006/046000
 (30) Priorité/Priority: 2004/10/26 (US10/973,322)

(51) Cl.Int./Int.Cl. *E21B 33/14* (2006.01),
E21B 47/00 (2006.01)
 (72) Inventeurs/Inventors:
 BADALAMENTI, ANTHONY M., US;
 BLANCHARD, KARL W., US;
 CROWDER, MICHAEL G., US;
 FAUL, RONALD R., US;
 GRIFFITH, JAMES E., US;
 ROGERS, HENRY E., US;
 TURTON, SIMON, US
 (73) Propriétaire/Owner:
 HALLIBURTON ENERGY SERVICES, INC., US
 (74) Agent: OGILVY RENAULT LLP/S.E.N.C.R.L.,S.R.L.

(54) Titre : PROCÉDES ET SYSTÈMES DE CIMENTATION A CIRCULATION INVERSE DANS LES FORMATIONS SOUTERRAINES
 (54) Title: METHODS AND SYSTEMS FOR REVERSE-CIRCULATION CEMENTING IN SUBTERRANEAN FORMATIONS



(57) Abrégé/Abstract:

Methods and systems for reverse-circulation cementing in subterranean formations are provided. An example of a method is a method of cementing casing (3) in a subterranean well bore (1), comprising inserting a casing into the well bore, the casing

(57) **Abrégé(suite)/Abstract(continued):**

comprising a casing shoe (4); equipping the casing with a well head (2), and a casing inner diameter pressure indicator (13); flowing an equilibrium fluid (11) into the well bore; flowing a cement composition (15) into the well bore after the equilibrium fluid; determining from the well-bore pressure indicator when the well bore pressure has reached a desired value; discontinuing the flow of cement composition into the well bore upon determining that the well bore pressure has reached a desired value; and permitting the cement composition to set in the subterranean formation. Examples of systems include systems for cementing casing in a well bore. A marker detector (17) may be installed to detect tag fluids (16).

(12) INTERNATIONAL APPLICATION PUBLISHED UNDER THE PATENT COOPERATION TREATY (PCT)

(19) World Intellectual Property Organization
International Bureau(43) International Publication Date
4 May 2006 (04.05.2006)

PCT

(10) International Publication Number
WO 2006/046000 A1(51) International Patent Classification⁷: **E21B 33/14,**
47/00(21) International Application Number:
PCT/GB2005/003854

(22) International Filing Date: 6 October 2005 (06.10.2005)

(25) Filing Language: English

(26) Publication Language: English

(30) Priority Data:
10/973,322 26 October 2004 (26.10.2004) US(71) Applicant (for all designated States except US): **HAL-**
LIBURTON ENERGY SERVICES, INC. [US/US]; P.O.
Box 1431, Duncan, OK 73533 (US).(71) Applicant (for MW only): **WAIN, Christopher, Paul**
[GB/GB]; A.A. Thornton & Co., 235 High Holborn,
London WC1V 7LE (GB).

(72) Inventors; and

(75) Inventors/Applicants (for US only): **BADALAMENTI,****Anthony, M.** [US/US]; 5426 Portage Rock Lane, Katy,
TX 77450 (US). **BLANCHARD, Karl, W.** [US/US];
13211 April Mist, Cypress, TX 77429 (US). **CROWDER,**
Michael, G. [US/US]; Route 1, Box 113-3, Orlando, OK
73073 (US). **FAUL, Ronald, R.** [US/US]; 3211 Sage
Terrace, Katy, TX 77450 (US). **GRIFFITH, James,**
E. [US/US]; Route 1, Box 69, Loco, OK 73442 (US).
ROGERS, Henry, E. [US/US]; 4015 West Seminole
Road, Duncan, OK 73533 (US). **TURTON, Simon**
[GB/US]; 1830 Leatherstem Lance, Kingwood, TX 77345
(US).(74) Agents: **WAIN, Christopher, Paul** et al.; A. A. Thornton
& Co, 235 High Holborn, London WC1V 7LE (GB).(81) Designated States (unless otherwise indicated, for every
kind of national protection available): AE, AG, AL, AM,
AT, AU, AZ, BA, BB, BG, BR, BW, BY, BZ, CA, CH, CN,
CO, CR, CU, CZ, DE, DK, DM, DZ, EC, EE, EG, ES, FI,
GB, GD, GE, GH, GM, HR, HU, ID, IL, IN, IS, JP, KE,
KG, KM, KP, KR, KZ, LC, LK, LR, LS, LT, LU, LV, LY,
MA, MD, MG, MK, MN, MW, MX, MZ, NA, NG, NI, NO,
NZ, OM, PG, PH, PL, PT, RO, RU, SC, SD, SE, SG, SK,

[Continued on next page]

(54) Title: METHODS AND SYSTEMS FOR REVERSE-CIRCULATION CEMENTING IN SUBTERRANEAN FORMATIONS

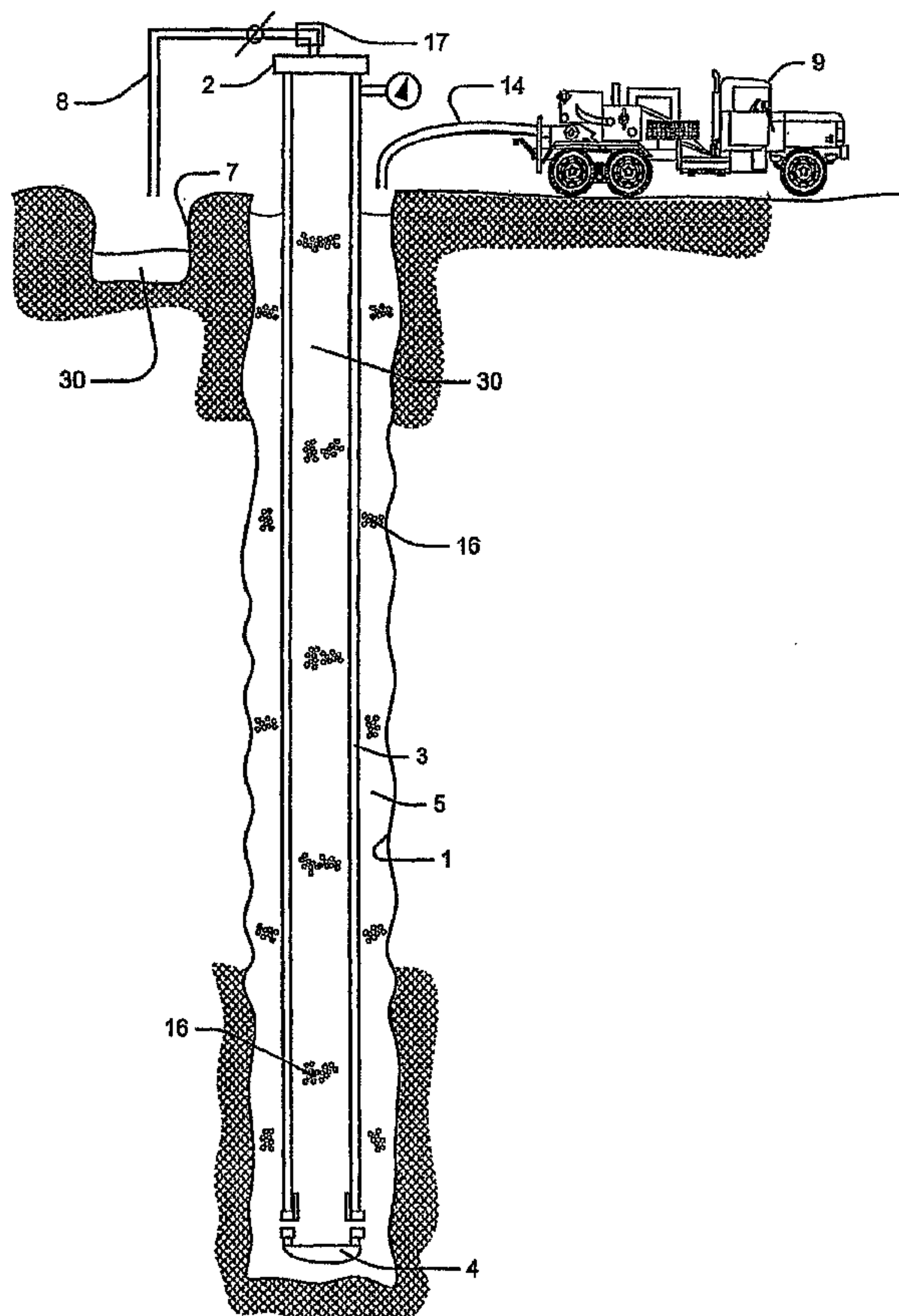
(57) Abstract: Methods and systems for reverse-circulation
cementing in subterranean formations are provided.
An example of a method is a method of cementing casing
(3) in a subterranean well bore (1), comprising inserting
a casing into the well bore, the casing comprising a cas-
ing shoe (4); equipping the casing with a well head (2),
and a casing inner diameter pressure indicator (13); flow-
ing an equilibrium fluid (11) into the well bore; flowing a
cement composition (15) into the well bore after the equi-
librium fluid; determining from the well-bore pressure in-
dicator when the well bore pressure has reached a desired
value; discontinuing the flow of cement composition into
the well bore upon determining that the well bore pressure
has reached a desired value; and permitting the cement
composition to set in the subterranean formation. Exam-
ples of systems include systems for cementing casing in
a well bore. A marker detector (17) may be installed to
detect tag fluids (16).

WO 2006/046000 A1

WO 2006/046000 A1

SL, SM, SY, TJ, TM, TN, TR, TT, TZ, UA, UG, US, UZ,
VC, VN, YU, ZA, ZM, ZW.

RO, SE, SI, SK, TR), OAPI (BF, BJ, CF, CG, CI, CM, GA,
GN, GQ, GW, ML, MR, NE, SN, TD, TG).

(84) Designated States (*unless otherwise indicated, for every kind of regional protection available*): ARIPO (BW, GH, GM, KE, LS, MW, MZ, NA, SD, SL, SZ, TZ, UG, ZM, ZW), Eurasian (AM, AZ, BY, KG, KZ, MD, RU, TJ, TM), European (AT, BE, BG, CH, CY, CZ, DE, DK, EE, ES, FI, FR, GB, GR, HU, IE, IS, IT, LT, LU, LV, MC, NL, PL, PT,

Published:

— *with international search report*

For two-letter codes and other abbreviations, refer to the "Guidance Notes on Codes and Abbreviations" appearing at the beginning of each regular issue of the PCT Gazette.

METHODS AND SYSTEMS FOR REVERSE-CIRCULATION CEMENTING IN SUBTERRANEAN FORMATIONS

BACKGROUND OF THE PRESENT INVENTION

The present invention relates to subterranean cementing operations, and more particularly, to methods and systems for reverse-circulation cementing in subterranean formations.

Hydraulic cement compositions commonly are utilized in subterranean operations, particularly subterranean well completion and remedial operations. For example, hydraulic cement compositions are used in primary cementing operations whereby pipe strings, such as casings and liners, are cemented in well bores. In performing primary cementing, hydraulic cement compositions commonly are pumped into an annular space between the walls of a well bore and the exterior surface of a pipe string disposed therein. The cement composition is permitted to set in the annular space, thereby forming therein an annular sheath of hardened, substantially impermeable cement that substantially supports and positions the pipe string in the well bore, and that bonds the exterior surface of the pipe string to the walls of the well bore. Conventionally, two pumping methods have been used to place the cement composition in the annulus. First, the cement composition may be pumped down the inner diameter of the pipe string, out through a casing shoe and/or circulation valve at the bottom of the pipe string, and up through the annulus to a desired location. The direction in which the cement composition is pumped in this first method is called a conventional-circulation direction. Second, the cement composition may be pumped directly down the annulus, thereby displacing any well fluids present in the annulus by pushing them through the casing shoe and up the inner diameter of the pipe string. The direction in which the cement composition is pumped in this second method is called a reverse-circulation direction.

In reverse-circulation direction applications, it is sometimes undesirable for the cement composition to enter the inner diameter of the pipe string from the annulus through the casing shoe and/or circulation valve. For example, if an excessive volume of cement composition is permitted to enter the inner diameter of the pipe string, the cement composition may rise to a level equal to that of a hydrocarbon-bearing zone intended to be perforated. This may be problematic because it may prevent the subsequent placement of tools (*e.g.*, perforating equipment) adjacent the hydrocarbon-bearing zone, which may prevent the perforation of the zone and subsequent production of hydrocarbons therefrom,

unless the excess cement is drilled out. Accordingly, whenever a cement composition that is reverse-circulated into a subterranean annulus enters the inner diameter of the pipe string, the excess cement composition in the pipe string typically is drilled out before further operations are conducted. The drill-out procedure often requires additional time, labor, and expense that may be avoided by preventing the excess cement composition from entering the inner diameter of the pipe string through the casing shoe and/or circulation valve.

SUMMARY OF THE PRESENT INVENTION

The present invention relates to subterranean cementing operations, and more particularly, to methods and systems for reverse-circulation cementing in subterranean formations.

An example of a method of the present invention is a method of cementing casing in a well bore, comprising: inserting a casing into the well bore, the casing having an inner diameter and an outer surface, an annulus being defined between the outer surface of the casing and an inner wall of the well bore; flowing an equilibrium fluid into the well bore; flowing a cement composition into the well bore after flowing the equilibrium fluid into the well bore; permitting the pressure in the annulus to reach equilibrium with the pressure in the inner diameter of the casing, such that flow of cement composition into the well bore ceases; and permitting the cement composition to set in the well bore.

Another example of a method of the present invention is a method of cementing casing in a well bore, comprising: inserting a casing into the well bore, the casing having an inner diameter and an outer surface, an annulus being defined between the outer surface of the casing and an inner wall of the well bore; flowing an equilibrium fluid into the well bore; flowing a cement composition into the well bore after flowing the equilibrium fluid into the well bore; monitoring the pressure in the inner diameter of the casing; discontinuing the flow of cement composition into the well bore upon determining that the pressure in the inner diameter of the casing has reached a desired value; and permitting the cement composition to set in the well bore.

Another example of a method of the present invention is a method of cementing casing in a well bore, comprising: inserting casing into the well bore; flowing a circulation fluid into the well bore; flowing a marker into the well bore at a desired time during the flowing of the circulation fluid into the well bore; determining when the marker reaches a desired location; monitoring a volume of circulation fluid after flowing the marker into the

well bore, and before determining when the marker reaches a desired location; determining a volume of cement composition to be flowed into the well bore; flowing the determined volume of cement composition into the well bore; and permitting the cement composition to set in the well bore.

Another example of a method of the present invention is a method of cementing casing in a well bore, comprising: inserting casing into the well bore; flowing a volume of circulation fluid, comprising a marker, into the well bore, the volume of circulation fluid being about equal to an inside volume of the casing; flowing a cement composition into the well bore after flowing the volume of circulation fluid; determining when the marker reaches a desired location; discontinuing flowing the cement composition into the well bore; and permitting the cement composition to set in the well bore.

An example of a system of the present invention is a system for cementing casing in a well bore comprising: a casing inserted into the well bore and defining an annulus therebetween; a cement composition for flowing into at least a portion of the annulus; and an equilibrium fluid that is positioned within the inner diameter of the casing and balances the static fluid pressures between the inner diameter of the casing and the annulus.

Another example of a system of the present invention is a system for cementing casing in a well bore comprising: a casing inserted into the well bore and defining an annulus therebetween, the casing having an inner diameter; a circulation fluid for flowing into the well bore, the circulation fluid having a leading edge that comprises a marker, and having a trailing edge, wherein the flow of the circulation fluid and marker into the well bore facilitates determination of a volume of cement composition sufficient to fill a desired portion of the annulus; a cement composition for flowing into at least a portion of the annulus, the cement composition having a leading edge in fluid communication with the trailing edge of the circulation fluid; and a marker detector in fluid communication with fluid passing through the inner diameter of the casing.

The features and advantages of the present invention will be readily apparent to those skilled in the art upon a reading of the description of embodiments, which follows.

BRIEF DESCRIPTION OF THE DRAWINGS

A more complete understanding of the present disclosure and advantages thereof may be acquired by referring to the following description taken in conjunction with the accompanying drawings, wherein:

Figure 1 illustrates a cross-sectional side view of a well bore and casing.

Figure 2A illustrates a cross-sectional side view of a well bore and casing.

Figure 2B illustrates a cross-sectional side view of the well bore and casing illustrated in **Figure 2A**.

Figure 3A illustrates a cross-sectional side view of a well bore and casing.

Figure 3B illustrates a cross-sectional side view of the well bore and casing illustrated in **Figure 3A**.

Figure 4A illustrates a cross-sectional side view of a well bore and casing.

Figure 4B illustrates a cross-sectional side view of the well bore and casing illustrated in **Figure 4A**.

While the present invention is susceptible to various modifications and alternative forms, specific embodiments thereof have been shown in the drawings and are herein described. It should be understood, however, that the description herein of specific embodiments is not intended to limit the invention to the particular forms disclosed, but on the contrary, the intention is to cover all modifications, equivalents, and alternatives falling within the spirit and scope of the present invention as defined by the appended claims.

DETAILED DESCRIPTION OF EMBODIMENTS

The present invention relates to subterranean cementing operations, and more particularly, to methods and systems for reverse-circulation cementing in subterranean formations. Generally, any cement compositions suitable for use in subterranean applications may be suitable for use in the present invention.

Referring to **Figure 1**, a cross-sectional side view of a well bore is shown. Well bore 1 is an open well bore with casing 3 inserted therein. Annulus 5 is defined between casing 3 and well bore 1. Casing 3 has casing shoe 4 at its lowermost end and simply extends from the open well bore at the top. Reservoir 7 is located proximate to well bore 1. Truck 9 is parked in the vicinity of well bore 1. Circulation fluid 30 is present within well bore 1 such that annular fluid surface 6 is approximately level with inner diameter fluid surface 10. In certain embodiments of the present invention, circulation fluid 30 that initially is present within well bore 1 may be a drilling fluid. **Figure 1** represents a typical well bore configuration prior to a cementing operation.

One aspect of the present invention provides a method for pumping a cement composition into annulus 5 without permitting excessive flow of cement composition into the

inside diameter of casing 3. In certain embodiments wherein the interior volume of casing 3 has not been calculated, a first step of the method may involve calculating the interior volume of casing 3. The interior volume of casing 3 equals the product of π multiplied by the square of the inside radius "r" of casing 3, multiplied by the length "h" of casing 3, as illustrated below:

$$V = \pi r^2 h$$

EQUATION 1

Next, equilibrium fluid 11 (not shown in Figure 1) may be selected having a density equal to the density of cement composition 15 (not shown in Figure 1) that will be used to cement casing 3 in well bore 1. Generally, equilibrium fluid 11 may comprise any fluid (*e.g.*, a drilling fluid, a spacer fluid, or the like) having a desired density (*e.g.*, a density greater than the density of circulation fluid 30), provided that the fluid is compatible with both circulation fluid 30 and cement composition 15. Examples of suitable spacer fluids are commercially available from Halliburton Energy Services, Inc., of Duncan, Oklahoma, under the trade names "TUNED SPACER,"* and "DUAL SPACER."* Equilibrium fluid 11 then may be pumped ahead of cement composition 15 into annulus 5 and into well bore 1 in a reverse-circulation direction. Equilibrium fluid 11 may travel down annulus 5, through casing shoe 4 and up through the inner diameter of casing 3. When equilibrium fluid 11 completely fills the inside of casing 3, cement composition 15 flowing behind equilibrium fluid 11 will completely fill annulus 5, and the static fluid pressure of equilibrium fluid 11 will balance the static fluid pressure of cement composition 15, such that the flow of cement composition 15 into annulus 5 may cease. In particular, annular fluid surface 6 (*e.g.*, the surface of cement composition 15 in the annulus) will be approximately level with inner diameter fluid surface 10 (*e.g.*, the surface of equilibrium fluid 11 in well bore 1). Generally, the leading edge of cement composition 15 will be at about adjacent the lowermost end of casing 3 when the flow of cement composition 15 into the annulus ceases. Generally, the leading edge of cement composition 15 will not penetrate the inner diameter of casing 3.

In certain embodiments of the present invention, an operator may elect to fill less than the entire annulus 5 with cement composition 15. For example, this may be desirable when casing 3 comprises an intermediate casing string (*e.g.*, a casing string having a depth of 10,000 feet, for example). In certain of these embodiments, an operator may determine an annular volume that is desired to be filled with cement composition 15 (*e.g.*, a volume that is less than the total annular volume), and may determine a desired volume of equilibrium fluid

* Trademark

11 to be placed ahead of the desired volume of cement composition 15. For example, if casing 3 comprises an intermediate casing string having a depth of 10,000 feet, for example, the operator may determine that the lower 2,500 feet should be filled with cement composition 15. In such example, the volume of equilibrium fluid 11 that is to be placed ahead of cement composition 15 may be calculated such that it fills an equivalent height within casing 3 (e.g., 2,500 feet in this example wherein the density of equilibrium fluid equals the density of cement composition 15), and thus the uppermost height of equilibrium fluid 11 and the uppermost height of cement composition 15 would equal each other below the surface (e.g., 7,500 feet below the surface, in this example). Generally, in these embodiments wherein less than the entire annulus 5 may be filled with cement composition 15, the remaining volume of annulus 5 would comprise a fluid (e.g., a drilling fluid, spacer fluid, or equilibrium fluid 11, or the like) above cement composition 15 that is compatible with cement composition 15 and that has about the same, or greater, density as circulation fluid 30, thereby providing approximately equal hydrostatic pressures on both sides of casing 3. Of course, other combinations of fluid lengths and densities may exist where the density of equilibrium fluid 11 differs from the density of cement composition 15. Generally, the resultant hydrostatic pressure of the fluids placed in the formation ahead of cement composition 15, which fill the inside of casing 3, will approximately equal the resultant hydrostatic pressure of the fluids within annulus 5, including, *inter alia*, cement composition 15.

Referring to Figures 2A and 2B, cross-sectional side views of a well bore and casing are shown. The well bore configuration generally is similar to that previously described with reference to Figure 1, though additional features are illustrated in Figures 2A and 2B. Well head 2 is attached to the exposed end of casing 3. Return line 8 extends from well head 2 to reservoir 7, and is in fluid communication with the inner diameter of casing 3. Return valve 12 is connected in return line 8. In certain embodiments of the present invention, return valve 12 may be a ball valve, a gate valve, a plug valve, or the like. An example of a suitable plug valve is commercially available from Halliburton Energy Services, Inc., of Duncan, Oklahoma, under the trade name "LO-TORC."^{*} Pressure indicator 13 is attached to casing 3, and indicates the pressure within casing 3 below well head 2. Supply line 14 is connected to truck 9 for pumping fluids into annulus 5. As shown in Figure 2A, the calculated volume of equilibrium fluid 11 has been pumped into annulus 5, thereby displacing a portion of

* Trademark

circulation fluid 30 from annulus 5 into reservoir 7. Because equilibrium fluid 11 is intended only to fill the inside diameter of casing 3, annulus 5 may not be completely filled with equilibrium fluid 11 at this stage of the process, or it may spill over into the inside diameter of casing 3 through casing shoe 4. Once the calculated volume of equilibrium fluid 11 (*e.g.*, a volume of equilibrium fluid 11 sufficient to fill the interior volume of casing 3) is pumped into annulus 5, cement composition 15 then may be pumped into annulus 5 behind equilibrium fluid 11.

As shown in **Figure 2B**, cement composition 15 generally may be pumped down annulus 5 so as to drive equilibrium fluid 11 through casing shoe 4 and up through an inner diameter of casing 3. Because the density of both equilibrium fluid 11 and cement composition 15 exceeds the density of circulation fluid 30, pressure indicator 13 generally will indicate a positive pressure throughout this process. As inner diameter fluid surface 10 (*e.g.*, the surface of equilibrium fluid 11 in well bore 1) becomes approximately level with annular fluid surface 6 (*e.g.*, the surface of cement composition 15 in annulus 5), the pressure indicated on pressure indicator 13 will approach zero. At this stage of the operation, equilibrium fluid 11 generally will completely fill the inner diameter of casing 3 and cement composition 15 generally will completely fill annulus 5, although, as noted previously herein, in certain embodiments of the present invention annulus 5 may be only partially filled with cement composition 15. Once the pressure indicated on pressure indicator 13 reads zero, cement composition 15 will have been circulated into position within annulus 5, with the leading edge of cement composition 15 adjacent to cement shoe 4, and pumping of cement composition 15 into annulus 5 generally will be halted. Thereafter, cement composition 15 generally will be allowed to reside in well bore 1 for a period of time sufficient to permit cement composition 15 to harden or solidify. Once cement composition 15 has solidified, a production pipe, or coiled tubing may be inserted into casing 3 to remove equilibrium fluid 11 from well bore 1. In certain embodiments of the present invention wherein it is desired to commence production, a completion brine may be placed in the well bore. In certain embodiments of the present invention, it may be desirable to place a drilling fluid in well bore 1 in preparation for drilling out casing shoe 4 and extending well bore 1 to a desired, deeper depth. For example, if casing 3 comprises a surface casing string, it may be desirable to drill out casing shoe 4, extend well bore 1 to a desired depth, and install additional strings of casing (*e.g.*, intermediate casing and/or production casing).

In alternative embodiments of the present invention, equilibrium fluid 11 may be heavier, or lighter, than cement composition 15. To ensure that the pressure indicated by pressure indicator 13 reads zero when the leading edge of cement composition 15 reaches casing shoe 4 (thereby indicating that cement composition 15 has been circulated into position in annulus 5, and that pumping of cement composition 15 may be discontinued), the combined hydrostatic pressure of circulation fluid 30 initially present in well bore 1 and equilibrium fluid 11 should equal the hydrostatic pressure of the volume of cement composition 15 that is desired to be placed in annulus 5. In one embodiment of the present invention, equilibrium fluid 11 may have a heavier density than the density of cement composition 15. The required volume of equilibrium fluid 11 (V_{ef11}) first may be calculated according to the following equation:

$$V_{ef11} = V_{tot} (\rho_{cc15} - \rho_{cf30}) / (\rho_{ef11} - \rho_{cf30}) \quad \text{EQUATION 2}$$

where V_{tot} is the interior volume of casing 3, ρ_{cc15} is the density of cement composition 15, ρ_{cf30} is the density of circulation fluid 30 in the well bore, and ρ_{ef11} is the density of equilibrium fluid 11. As noted earlier, from Equation 1, $V_{tot} = \pi r^2 h$, where r is the inside radius of casing 3 and h is the height or length of casing 3. The following example illustrates how the required volume of equilibrium fluid (V_{ef}) is calculated.

EXAMPLE

For example, assume that casing 3 has a length of 2,000 feet, and an internal diameter of 5 inches. Assume further that the desired length of casing 3 to be cemented is 2,000 feet. Accordingly, the radius of casing 3 will be 2.5 inches. Thus, $V_{tot} = H \pi r^2 = [(2000 \text{ feet})(3.1416)((2.5 \text{ inch})^2/144)]/(5.614583) = 48.6$ barrels. Further assume that the desired cement composition 15 has a density of 80 lbs/ft³, that circulation fluid 30 has a density of 65 lbs/ft³, and that the desired equilibrium fluid 11 has a density of 100 lbs/ft³. Accordingly, applying EQUATION 2, $V_{ef} = V_{tot} (\rho_{cc15} - \rho_{cf30}) / (\rho_{ef11} - \rho_{cf30}) = 48.6$ barrels $(80 \text{ lbs/ft}^3 - 65 \text{ lbs/ft}^3) / (100 \text{ lbs/ft}^3 - 65 \text{ lbs/ft}^3) = 20.8$ barrels. Thus, in this example, 20.8 barrels of equilibrium fluid 11 would be required for use in order to ensure that the pressure displayed by pressure indicator 13 read zero when the leading edge of cement composition 15 reached casing shoe 4.

Where a relatively heavy equilibrium fluid 11 is used, it may be injected into annulus 5 immediately in front of cement composition 15. For example, Figure 3A illustrates

equilibrium fluid 11 being placed within annulus 5 in advance of cement composition 15. Because equilibrium fluid 11 and cement composition 15 are heavier than circulation fluid 30 in the inner diameter of casing 3, the fluids flow in a reverse-circulation direction. Further, the relatively heavier equilibrium fluid 11 and cement composition 15 induce an elevated pressure in the inner diameter of casing 3, as would be indicated on pressure indicator 13. Return valve 12 may be used to reduce or restrict the fluid flow through return line 8 to a desired rate. For example, return valve 12 may be partially closed to thereby modulate the rate of fluid flow therethrough. Alternatively, a choke manifold or an adjustable choke valve may be placed in return line 8 (*e.g.*, generally downstream of return valve 12). The desired reduction or restriction in the flow rate of fluid through return line 8 may be determined by, *inter alia*, iteratively restricting the flow rate while monitoring the flow rate either visually or through an optional flowmeter.

As shown in **Figure 3B**, additional portions of cement composition 15 may be placed in annulus 5 behind equilibrium fluid 11 until annulus 5 is completely filled with cement composition 15. As equilibrium fluid 11 enters the inner diameter of casing 3 through casing shoe 4, the pressure indicated on pressure indicator 13 begins to decline. Once the hydrostatic fluid pressure generated by circulation fluid 30 and equilibrium fluid 11 in the inner diameter of casing 3 becomes approximately equal to the hydrostatic fluid pressure generated by cement composition 15 in annulus 5, the fluids will no longer flow through well bore 1, and will be in static equilibrium, as shown in **Figure 3B**, because, in this embodiment, equilibrium fluid 11 is much heavier than cement composition 15.

Figures 4A and 4B illustrate alternative embodiments of the present invention. As illustrated, casing 3 is inserted in well bore 1. Annulus 5 is defined between casing 3 and well bore 1. Casing 3 has casing shoe 4. Reservoir 7 and truck 9 are located near well bore 1. Supply line 14 is connected to truck 9 for pumping fluids into annulus 5.

As illustrated with reference to **Figures 4A and 4B**, in certain of these embodiments of the present invention, the mass flow rate and/or volumetric flow rate of returning circulation fluid 30 may be monitored with marker detector 17. In certain embodiments of the present invention, marker detector 17 may comprise, *e.g.*, mass flow meters and/or borax detectors 17. Suitable mass flow meters are commercially available from, *inter alia*, MicroMotion Corporation of Boulder, Colorado. Tag fluids 16 (*e.g.*, marker pills comprising, *inter alia*, fibers, cellophane flakes, walnut shells, and the like) may be injected

into circulation fluid 30 several barrels ahead of cement composition 15 so that the detection of tag fluids or marker pills 16 at the leading edge of circulation fluid 30 may signal to an operator the impending arrival of the leading edge of cement composition 15 at a desired location (*e.g.*, the impending arrival of the leading edge of cement composition 15 at about the lowermost end of casing 3). Generally, the leading edge of cement composition 15 will not penetrate the inner diameter of casing 3.

As shown in **Figure 4A**, tag fluids or marker pills 16 are injected into annulus 5 as circulation fluid 30 is pumped from truck 9, down through annulus 5, into the inner diameter of casing 3 through casing shoe 4, up through the inner diameter of casing 3 and through return line 8 into reservoir 7. Generally, circulation fluid 30 will have a greater density than the density of any formation fluids (not shown) or other fluids (not shown) that already may be present within annulus 5. In certain embodiments of the present invention, when cement composition 15 is flowed into annulus 5, a leading edge of cement composition 15 will be in fluid communication with a trailing edge of circulation fluid 30.

Marker detector 17 may be positioned in a variety of locations. In certain embodiments of the present invention, marker pills 16 are observed by marker detector 17 as they pass through return line 8. In certain embodiments of the present invention, marker detector 17 may be disposed such that it is in fluid communication with fluid passing through the inner diameter of casing 3. In certain embodiments of the present invention, marker detector 17 may be disposed such that it is in fluid communication with fluid passing through well head 2. In certain embodiments of the present invention, marker detector 17 may be disposed such that it is positioned in the inner diameter of casing 3 at about the mouth of well bore 1. In certain embodiments of the present invention, marker detector 17 may be disposed such that it is positioned in the inner diameter of casing 3, below the mouth of well bore 1. In certain embodiments of the present invention, marker detector 17 may be connected to a wireline (not shown) that is disposed within the inner diameter of casing 3, below the mouth of well bore 1. In certain embodiments of the present invention, marker detector 17 may be disposed such that it is positioned in the inner diameter of casing 3, at a depth within the upper 25% of the length of casing 3. In certain embodiments of the present invention, marker detector 17 may be disposed such that it is positioned in the inner diameter of casing 3, at a depth below about the upper 25% of the length of casing 3.

In certain embodiments of the present invention, more than one sample of tag fluids or marker pills 16 may be injected into annulus 5, and the volume of circulation fluid 30 injected between samples of tag fluids or marker pills 16 may be monitored.

In certain embodiments of the present invention wherein the inner volume of casing 3 is known, tag fluids or marker pills 16 may be injected into annulus 5 as circulation fluid 30 is pumped from truck 9, and, after flowing into annulus 5 a volume of circulation fluid 30 that is about equal to the inner volume of casing 3, cement composition 15 may be flowed into annulus 5. In certain of such embodiments, the arrival of tag fluids or marker pills 16 at marker detector 17 will signal the impending arrival of the leading edge of cement composition 15 at about the lowermost end of casing 3 (e.g., at about casing shoe 4), and will indicate that the flow of cement composition 15 into annulus 5 may be discontinued.

As shown in **Figure 4B**, tag fluids or marker pills 16 facilitate the injection of the proper amount of cement composition 15 into annulus 5. Knowing the inner diameter volume of casing 3 and having observed the volume of circulation fluid 30 that had passed through well bore 1 when marker pills 16 were observed at marker detector 17 facilitates calculation of the volume of cement composition 15 to be pumped into annulus 5 to fill annulus 5 without permitting cement composition 15 to flow into casing 3. In certain optional embodiments of the present invention, an optional flow meter may be used that may comprise a totalizer that may identify the total volume of circulation fluid 30 that has passed through well bore 1 at the time when marker pills 16 are detected. Optionally, the total volume of circulation fluid 30 that has passed through well bore 1 at the time of detection of marker pills 16 may be estimated by monitoring the fluid level in reservoir 7, which may have gradations or other markings that may be useful in determining the fluid volume therein. In certain embodiments of the present invention, the use of more than one sample of tag fluids or marker pills 16 may facilitate improved accuracy in measuring, *inter alia*, the fluid volume of the inner diameter of casing 3, and the fluid volume of annulus 5. In certain embodiments of the present invention, once the fluid volume of annulus 5 has been measured accurately, a corresponding volume of cement composition 15 may be reverse circulated into annulus 5, as illustrated in **Figure 4B**.

Accordingly, an example of a method of the present invention is a method of cementing casing in a well bore, comprising: inserting a casing into the well bore, the casing having an inner diameter and an outer surface, an annulus being defined between the outer

surface of the casing and an inner wall of the well bore; flowing an equilibrium fluid into the well bore; flowing a cement composition into the well bore after flowing the equilibrium fluid into the well bore; permitting the pressure in the annulus to reach equilibrium with the pressure in the inner diameter of the casing, such that flow of cement composition into the well bore ceases; and permitting the cement composition to set in the well bore.

Another example of a method of the present invention is a method of cementing casing in a well bore, comprising: inserting a casing into the well bore, the casing having an inner diameter and an outer surface, an annulus being defined between the outer surface of the casing and an inner wall of the well bore; flowing an equilibrium fluid into the well bore; flowing a cement composition into the well bore after flowing the equilibrium fluid into the well bore; monitoring the pressure in the inner diameter of the casing; discontinuing the flow of cement composition into the well bore upon determining that the pressure in the inner diameter of the casing has reached a desired value; and permitting the cement composition to set in the well bore.

Another example of a method of the present invention is a method of cementing casing in a well bore, comprising: inserting casing into the well bore; flowing a circulation fluid into the well bore; flowing a marker into the well bore at a desired time during the flowing of the circulation fluid into the well bore; determining when the marker reaches a desired location; monitoring a volume of circulation fluid after flowing the marker into the well bore, and before determining when the marker reaches a desired location; determining a volume of cement composition to be flowed into the well bore; flowing the determined volume of cement composition into the well bore; and permitting the cement composition to set in the well bore.

Another example of a method of the present invention is a method of cementing casing in a well bore, comprising: inserting casing into the well bore; flowing a volume of circulation fluid, comprising a marker, into the well bore, the volume of circulation fluid being about equal to an inside volume of the casing; flowing a cement composition into the well bore after flowing the volume of circulation fluid; determining when the marker reaches a desired location; discontinuing flowing the cement composition into the well bore; and permitting the cement composition to set in the well bore.

An example of a system of the present invention is a system for cementing casing in a well bore comprising: a casing inserted into the well bore and defining an annulus

therebetween; a cement composition for flowing into at least a portion of the annulus; and an equilibrium fluid that is positioned within the inner diameter of the casing and balances the static fluid pressures between the inner diameter of the casing and the annulus.

Another example of a system of the present invention is a system for cementing casing in a well bore comprising: a casing inserted into the well bore and defining an annulus therebetween, the casing having an inner diameter; a circulation fluid for flowing into the well bore, the circulation fluid having a leading edge that comprises a marker, and having a trailing edge, wherein the flow of the circulation fluid and marker into the well bore facilitates determination of a volume of cement composition sufficient to fill a desired portion of the annulus; a cement composition for flowing into at least a portion of the annulus, the cement composition having a leading edge in fluid communication with the trailing edge of the circulation fluid; and a marker detector in fluid communication with fluid passing through the inner diameter of the casing.

Therefore, the present invention is well adapted to carry out the objects and attain the ends and advantages mentioned as well as those which are inherent therein. While the invention has been depicted, and described by reference to embodiments of the present invention, such a reference does not imply a limitation on the invention, and no such limitation is to be inferred. The invention is capable of considerable modification, alternation, and equivalents in form and function, as will occur to those ordinarily skilled in the pertinent arts and having the benefit of this disclosure. The depicted and described embodiments of the present invention are exemplary only, and are not exhaustive of the scope of the present invention. Consequently, the invention is intended to be limited only by the spirit and scope of the appended claims, giving full cognizance to equivalents in all respects.

What is claimed is:

1. A method of cementing casing in a well bore, comprising:
 - inserting a casing into the well bore, the casing having an inner diameter and an outer surface, an annulus being defined between the outer surface of the casing and an inner wall of the well bore;
 - flowing an equilibrium fluid into the well bore;
 - flowing a cement composition into the well bore after flowing the equilibrium fluid into the well bore;
 - permitting the pressure in the annulus to reach equilibrium with the pressure in the inner diameter of the casing, such that flow of cement composition into the well bore ceases; and
 - permitting the cement composition to set in the well bore.
2. The method of claim 1 wherein the casing comprises a well head and a casing inner diameter pressure indicator.
3. The method of claim 2 further comprising determining from the casing inner diameter pressure indicator when the casing inner diameter pressure has reached a desired value.
4. The method of claim 1 wherein flowing an equilibrium fluid into the well bore comprises flowing the equilibrium fluid into the well bore in a reverse-circulation direction.
5. The method of claim 1 wherein flowing a cement composition into the well bore after flowing the equilibrium fluid comprises flowing the cement composition into the well bore in a reverse-circulation direction.
6. The method of claim 1 wherein the cement composition has a leading edge, and wherein the leading edge of the cement composition is about adjacent a lowermost end of the casing when the flow of cement composition into the well bore ceases.
7. The method of claim 6 wherein the leading edge of the cement composition does not penetrate the inner diameter of the casing.
8. The method of claim 1 wherein the density of the equilibrium fluid is about equal to the density of the cement composition.
9. The method of claim 1 wherein the cement composition has a leading edge, and wherein the equilibrium fluid and the cement composition each have a density such that when

the leading edge of the cement composition is about adjacent the lowermost end of the casing, the static fluid pressure of a fluid column in the annulus is about equal to a static fluid pressure of a fluid column in the casing inner diameter.

10. The method of claim 1 wherein the equilibrium fluid comprises a drilling fluid.

11. The method of claim 1 wherein the equilibrium fluid comprises a spacer fluid.

12. The method of claim 3 wherein the desired value of the casing inner diameter pressure is about zero.

13. The method of claim 1 wherein the density of the equilibrium fluid is greater than the density of the cement composition.

14. The method of claim 1 wherein the density of the equilibrium fluid is less than the density of the cement composition.

15. The method of claim 13 wherein the well bore comprises a first fluid prior to flowing an equilibrium fluid into the well bore, wherein the cement composition has a leading edge, and wherein when the leading edge of the cement composition is about adjacent to a lowermost end of the casing, the static fluid pressure of a fluid column in the annulus is about equal to the static fluid pressure of a fluid column in the inner diameter of the casing.

16. The method of claim 14 wherein the well bore comprises a first fluid prior to flowing an equilibrium fluid into the well bore, wherein the cement composition has a leading edge, and wherein when the leading edge of the cement composition is about adjacent to a lowermost end of the casing, the static fluid pressure of a fluid column in the annulus is about equal to the static fluid pressure of a fluid column in the inner diameter of the casing.

17. The method of claim 1 further comprising calculating a desired volume of equilibrium fluid.

18. The method of claim 17 wherein calculating a desired volume of equilibrium fluid is performed before flowing an equilibrium fluid into the well bore.

19. The method of claim 17 wherein the casing has an interior volume, and wherein calculating a desired volume of equilibrium fluid to be injected comprises equating the desired volume of equilibrium fluid to the interior volume of the casing.

20. The method of claim 19 wherein a first fluid is present in the well bore prior to flowing an equilibrium fluid into the well bore, and wherein calculating the desired volume of equilibrium fluid to be injected comprises:

determining the difference in densities of the cement composition and the first fluid by subtracting the density of the first fluid from the density of the cement composition;

determining a product by multiplying the inner volume of the casing by the difference in densities of the cement composition and the first fluid;

determining the difference in densities of the equilibrium fluid and the first fluid by subtracting the density of the first fluid from the density of the equilibrium fluid; and

dividing the product by the difference in densities of the equilibrium fluid and the first fluid.

21. The method of claim 1 further comprising inserting coiled tubing into the inner diameter of the casing and circulating equilibrium fluid out of the inner diameter to the surface.

22. A method of cementing casing in a well bore, comprising:

inserting a casing into the well bore, the casing having an inner diameter and an outer surface, an annulus being defined between the outer surface of the casing and an inner wall of the well bore;

flowing an equilibrium fluid into the well bore;

flowing a cement composition into the well bore after flowing the equilibrium fluid into the well bore;

monitoring the pressure in the inner diameter of the casing;

discontinuing the flow of cement composition into the well bore upon determining that the pressure in the inner diameter of the casing has reached a desired value; and

permitting the cement composition to set in the well bore.

23. The method of claim 22 wherein the casing comprises a well head, and a casing inner diameter pressure indicator.

24. The method of claim 23 further comprising determining from the casing inner diameter pressure indicator when the pressure in the inner diameter of the casing has reached a desired value.

25. The method of claim 22 wherein flowing an equilibrium fluid into the well bore comprises flowing the equilibrium fluid into the well bore in a reverse-circulation direction.

26. The method of claim 22 wherein flowing a cement composition into the well bore after flowing the equilibrium fluid comprises flowing the cement composition into the well bore in a reverse-circulation direction.

27. The method of claim 22 wherein the cement composition has a leading edge, and wherein the leading edge of the cement composition is about adjacent a lowermost end of the casing when the flow of cement composition into the well bore is discontinued.

28. The method of claim 27 wherein the leading edge of the cement composition does not penetrate the inner diameter of the casing.

29. The method of claim 22 wherein the density of the equilibrium fluid is about equal to the density of the cement composition.

30. The method of claim 22 wherein the cement composition has a leading edge, and wherein the equilibrium fluid and the cement composition each have a density such that when the leading edge of the cement composition is about adjacent a lowermost end of the casing, the static fluid pressure of a fluid column in the annulus is about equal to the static fluid pressure of a fluid column in the casing inner diameter.

31. The method of claim 22 wherein the equilibrium fluid comprises a drilling fluid.

32. The method of claim 22 wherein the equilibrium fluid comprises a spacer fluid.

33. The method of claim 24 wherein the desired value of the well bore pressure is about zero.

34. The method of claim 22 wherein the density of the equilibrium fluid is greater than the density of the cement composition.

35. The method of claim 22 wherein the density of the equilibrium fluid is less than the density of the cement composition.

36. The method of claim 34 wherein the well bore comprises a first fluid prior to flowing an equilibrium fluid into the well bore, wherein the cement composition has a leading edge, and wherein when the leading edge of the cement composition is about adjacent to a lowermost end of the casing, the static fluid pressure of a fluid column in the annulus is about equal to the static fluid pressure of a fluid column in the inner diameter of the casing.

37. The method of claim 35 wherein the well bore comprises a first fluid prior to flowing an equilibrium fluid into the well bore, wherein the cement composition has a

leading edge, and wherein when the leading edge of the cement composition is about adjacent to a lowermost end of the casing, the static fluid pressure of a fluid column in the annulus is about equal to the static fluid pressure of a fluid column in the inner diameter of the casing.

38. The method of claim 22 further comprising calculating a desired volume of equilibrium fluid.

39. The method of claim 38 wherein calculating a desired volume of equilibrium fluid is performed before flowing an equilibrium fluid into the well bore.

40. The method of claim 39 wherein the casing has an interior volume, and wherein calculating a desired volume of equilibrium fluid to be injected comprises equating the desired volume of equilibrium fluid to the interior volume of the casing.

41. The method of claim 40 wherein a first fluid is present in the well bore prior to flowing an equilibrium fluid into the well bore, and wherein calculating the desired volume of equilibrium fluid to be injected comprises:

determining the difference in densities of the cement composition and the first fluid by subtracting the density of the first fluid from the density of the cement composition;

determining a product by multiplying the inner volume of the casing by the difference in densities of the cement composition and the first fluid;

determining the difference in densities of the equilibrium fluid and the first fluid by subtracting the density of the first fluid from the density of the equilibrium fluid; and

dividing the product by the difference in densities of the equilibrium fluid and the first fluid.

42. The method of claim 22 further comprising inserting coiled tubing into the inner diameter of the casing and circulating equilibrium fluid out of the inner diameter to the surface.

43. A method of cementing casing in a well bore, comprising:

inserting casing into the well bore;

flowing a circulation fluid into the well bore;

flowing a marker into the well bore at a desired time during the flowing of the circulation fluid into the well bore;

determining when the marker reaches a desired location;

monitoring a volume of circulation fluid after flowing the marker into the well bore, and before determining when the marker reaches a desired location;

determining a volume of cement composition to be flowed into the well bore;
flowing the determined volume of cement composition into the well bore; and
permitting the cement composition to set in the well bore.

44. The method of claim 43 wherein the well bore has a mouth, and wherein the desired location is a position in the inner diameter of the casing at about the mouth of the well bore.

45. The method of claim 43 wherein the well bore has a mouth, wherein a conduit is disposed above the mouth of the well bore in fluid communication with fluid passing through the inner diameter of the casing, and wherein the desired location is a position in the inside diameter of the conduit disposed above the mouth of the well bore.

46. The method of claim 43 wherein flowing a circulation fluid into the well bore comprises flowing the circulation fluid into the well bore in a reverse-circulation direction.

47. The method of claim 43 wherein flowing the volume of cement composition into the well bore after the circulation fluid comprises flowing the volume of cement composition into the well bore in a reverse-circulation direction.

48. The method of claim 43 wherein the well bore has a mouth, further comprising providing a marker detector at a position above the mouth of the well bore, the marker detector being in fluid communication with fluid passing through the inner diameter of the casing, and wherein determining when the marker reaches a desired location comprises determining from the marker detector when the marker reaches a position above the mouth of the well bore.

49. The method of claim 43 wherein the cement composition has a leading edge, wherein the casing has an inner diameter, and wherein the leading edge of the cement composition does not penetrate the inner diameter of the casing.

50. The method of claim 43 wherein the cement composition has a leading edge, and wherein the leading edge of the cement composition is about adjacent a lowermost end of the casing when the cement composition is permitted to set in the subterranean formation.

51. The method of claim 48 wherein the marker detector comprises a borax detector.

52. The method of claim 48 wherein the marker detector comprises a mass flow meter.

53. The method of claim 43 wherein the marker comprises at least one of a fiber, a cellophane flake, and a walnut shell.

54. The method of claim 43 wherein the casing has an inner diameter; and further comprising monitoring a time interval between flowing a marker into the well bore and the step of determining when the marker reached a desired location; and wherein determining a volume of cement composition to be placed into the well bore comprises determining the volume of circulation fluid that has been flowed into the well bore during the monitored time interval, and subtracting the volume of the inner diameter of the casing from the determined volume of circulation fluid.

55. A method of cementing casing in a well bore, comprising:
inserting casing into the well bore;
flowing a volume of circulation fluid, comprising a marker, into the well bore, the volume of circulation fluid being about equal to an inside volume of the casing;
flowing a cement composition into the well bore after flowing the volume of circulation fluid;
determining when the marker reaches a desired location;
discontinuing flowing the cement composition into the well bore; and
permitting the cement composition to set in the well bore.

56. The method of claim 55 wherein the well bore has a mouth, and wherein the desired location is a position in the inner diameter of the casing at about the mouth of the well bore.

57. The method of claim 55 wherein the well bore has a mouth, wherein a conduit is disposed above the mouth of the well bore in fluid communication with fluid passing through the inner diameter of the casing, and wherein the desired location is a position in the inside diameter of the conduit disposed above the mouth of the well bore.

58. The method of claim 55 wherein flowing a volume of circulation fluid, comprising a marker, into the well bore comprises flowing the volume of circulation fluid, comprising the marker, into the well bore in a reverse-circulation direction.

59. The method of claim 55 wherein flowing the cement composition into the well bore after flowing the volume of circulation fluid comprises flowing the cement composition into the well bore in a reverse-circulation direction.

60. The method of claim 55 wherein the well bore has a mouth, and further comprising providing a marker detector at a position above the mouth of the well bore, the marker detector being in fluid communication with fluid passing through the inner diameter

of the casing, and wherein determining when the marker reaches a desired location comprises determining from the marker detector when the marker reaches a desired location.

61. The method of claim 55 wherein the cement composition has a leading edge, wherein the casing has an inner diameter, and wherein the leading edge of the cement composition does not penetrate the inner diameter of the casing.

62. The method of claim 55 wherein the cement composition has a leading edge, and wherein the leading edge of the cement composition is about adjacent a lowermost end of the casing when the cement composition is permitted to set in the subterranean formation.

63. The method of claim 60 wherein the marker detector comprises a borax detector.

64. The method of claim 60 wherein the marker detector comprises a mass flow meter.

65. The method of claim 55 wherein the marker comprises at least one of a fiber, a cellophane flake, and a walnut shell.

66. A system for cementing casing in a well bore comprising:

a casing inserted into the well bore and defining an annulus therebetween;

a cement composition for flowing into at least a portion of the annulus; and

an equilibrium fluid that is positioned within the inner diameter of the casing and balances the static fluid pressures between the inner diameter of the casing and the annulus.

67. The system of claim 66 wherein the equilibrium fluid is a spacer fluid.

68. The system of claim 66 wherein the equilibrium fluid is a drilling fluid.

69. The system of claim 66 wherein the cement composition is flowed into the at least a portion of the annulus in a reverse circulation direction.

70. A system for cementing casing in a well bore comprising:

a casing inserted into the well bore and defining an annulus therebetween, the casing having an inner diameter;

a circulation fluid for flowing into the well bore, the circulation fluid having a leading edge that comprises a marker, and having a trailing edge, wherein the flow of the circulation fluid and marker into the well bore facilitates determination of a volume of cement composition sufficient to fill a desired portion of the annulus;

a cement composition for flowing into at least a portion of the annulus, the cement composition having a leading edge in fluid communication with the trailing edge of the circulation fluid; and

a marker detector in fluid communication with fluid passing through the inner diameter of the casing.

71. The system of claim 70 wherein the marker detector is located at a position above a mouth of the well bore.

72. The system of claim 70 wherein the marker detector is located at a position at about a mouth of the well bore.

73. The system of claim 70 wherein the marker detector is located at a position below a mouth of the well bore.

74. The system of claim 73 wherein the marker detector is connected to a wireline disposed within the inner diameter of the casing.

75. The system of claim 73 wherein the casing has a length, and wherein the marker detector is located at a position within about the upper 25% of the casing length.

76. The system of claim 73 wherein the casing has a length, and wherein the marker detector is located at a position below about the upper 25% of the casing length.

77. The system of claim 70 wherein the cement composition and the circulation fluid are flowed into the well bore in a reverse circulation direction.

78. The system of claim 70 wherein the marker detector is a borax detector.

79. The system of claim 70 wherein the marker detector is a mass flow meter.

80. The system of claim 70 wherein the marker comprises at least one of a fiber, a cellophane flake, and a walnut shell.

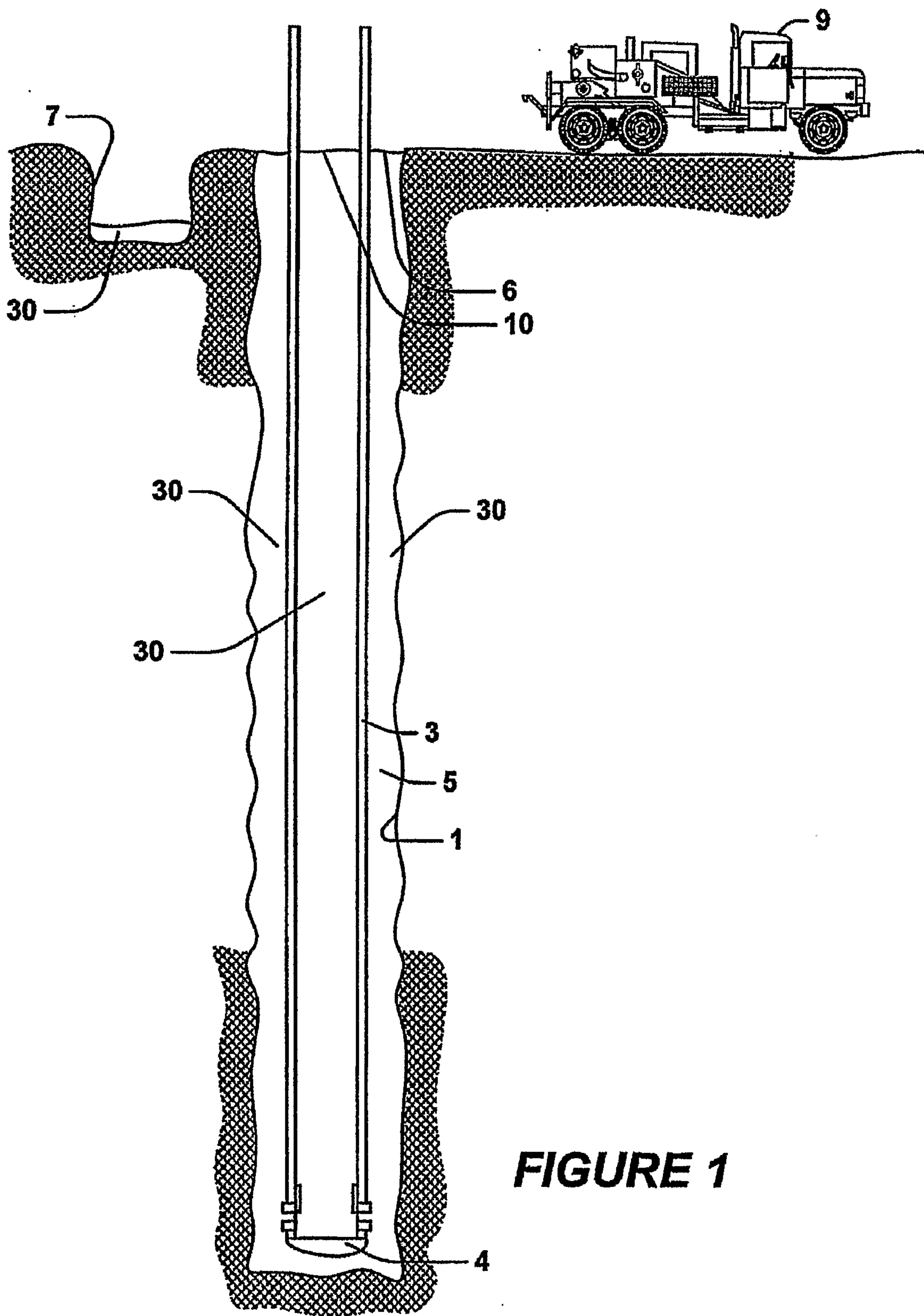

FIGURE 1

2/7

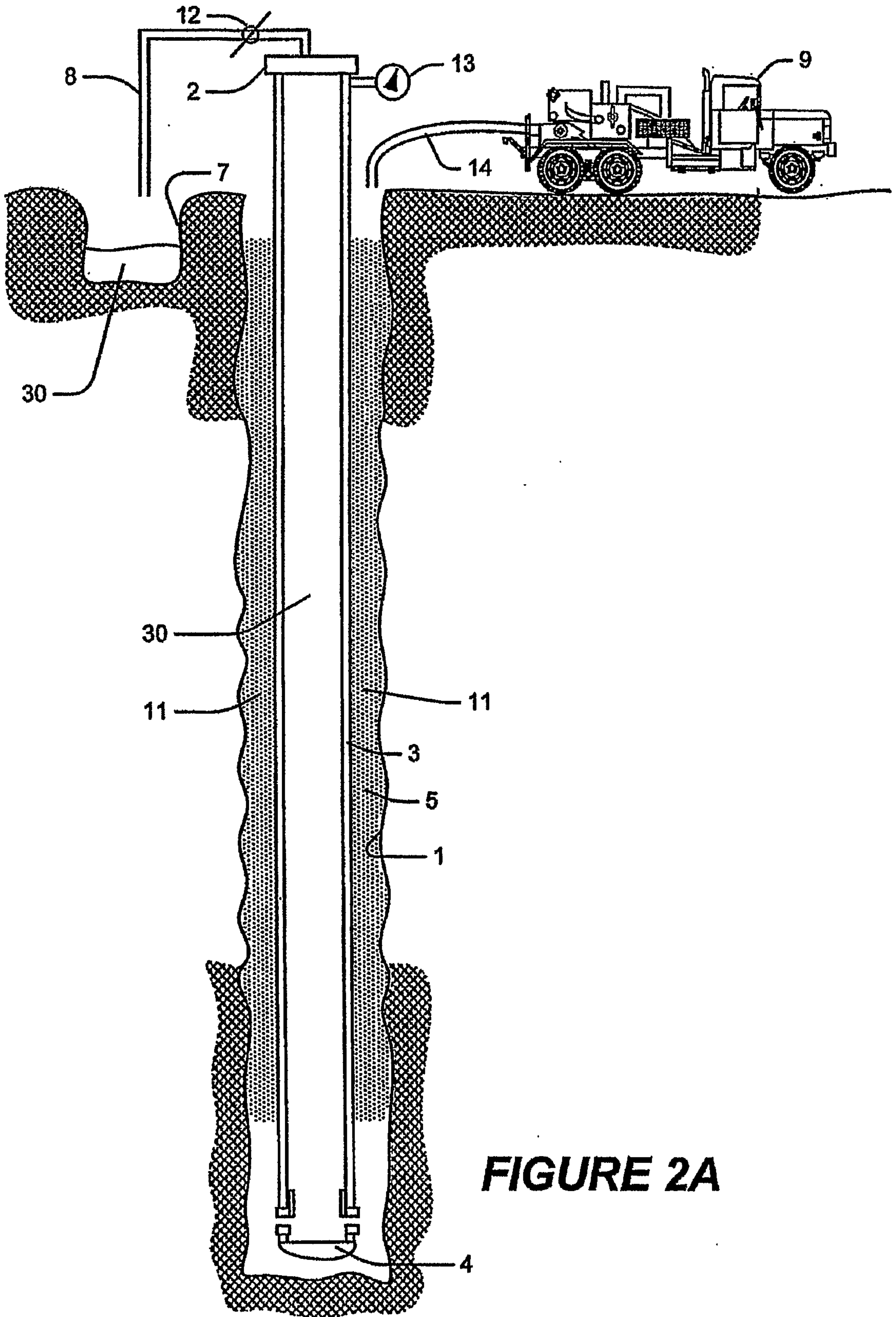
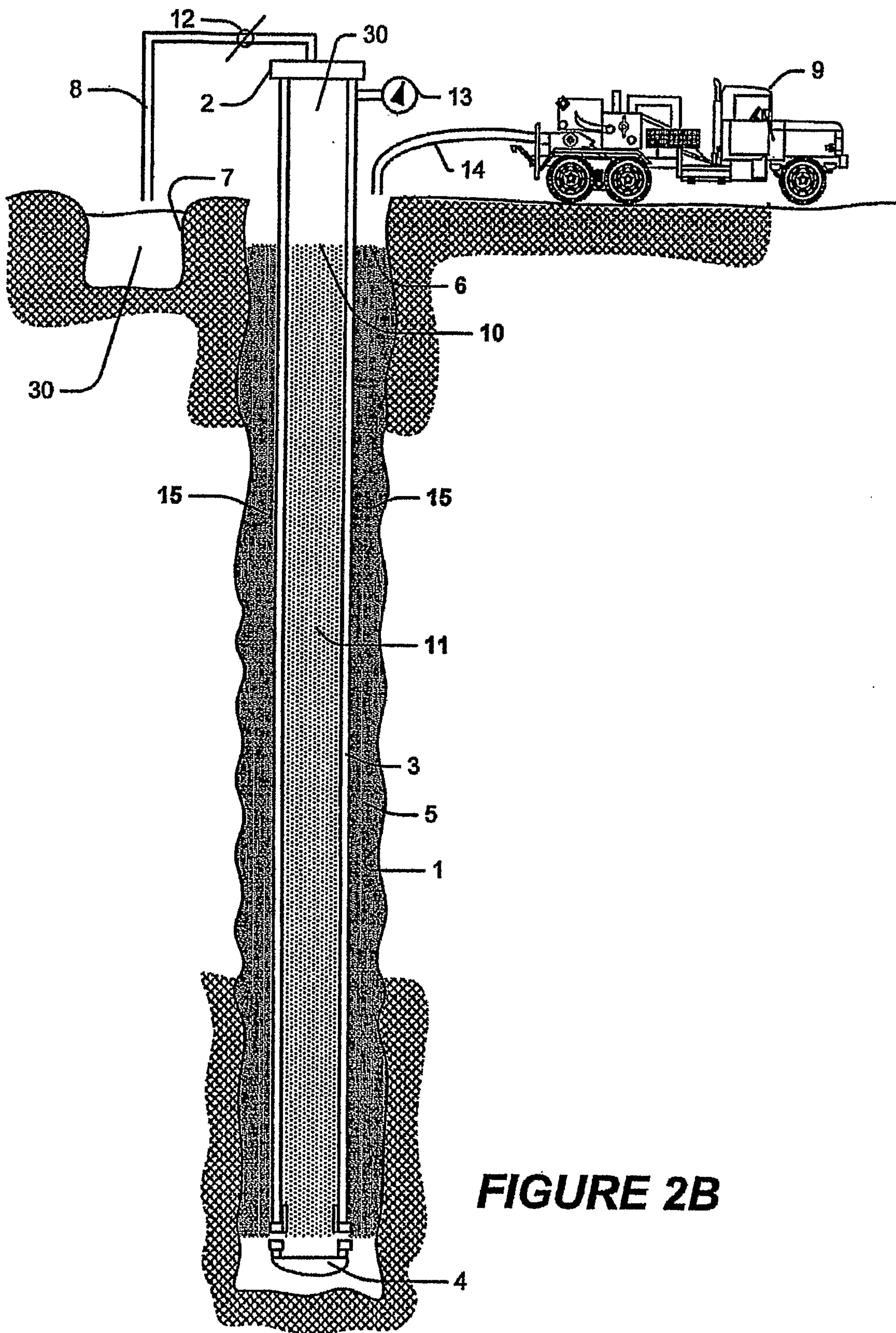

FIGURE 2A



4/7

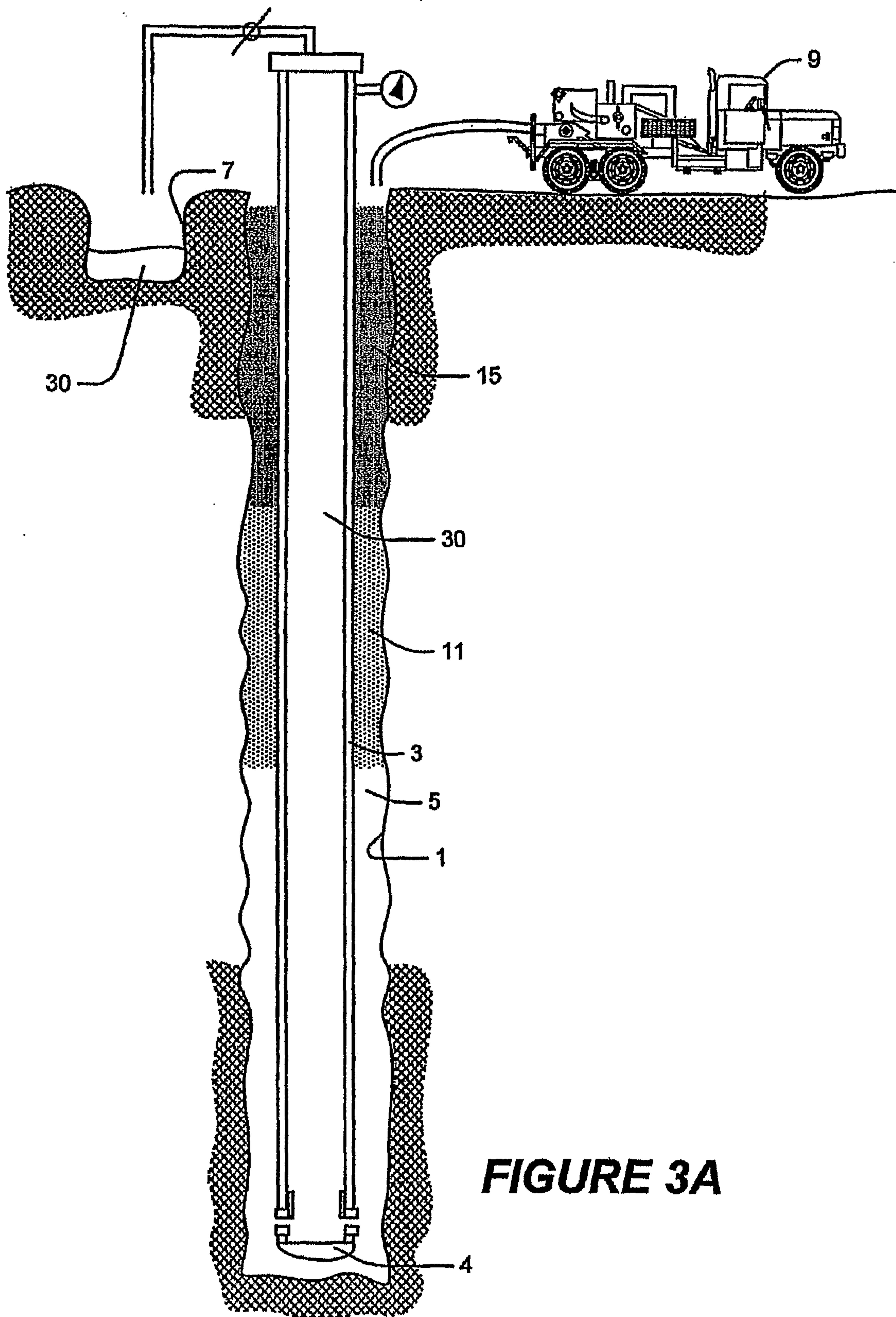

FIGURE 3A

5/7

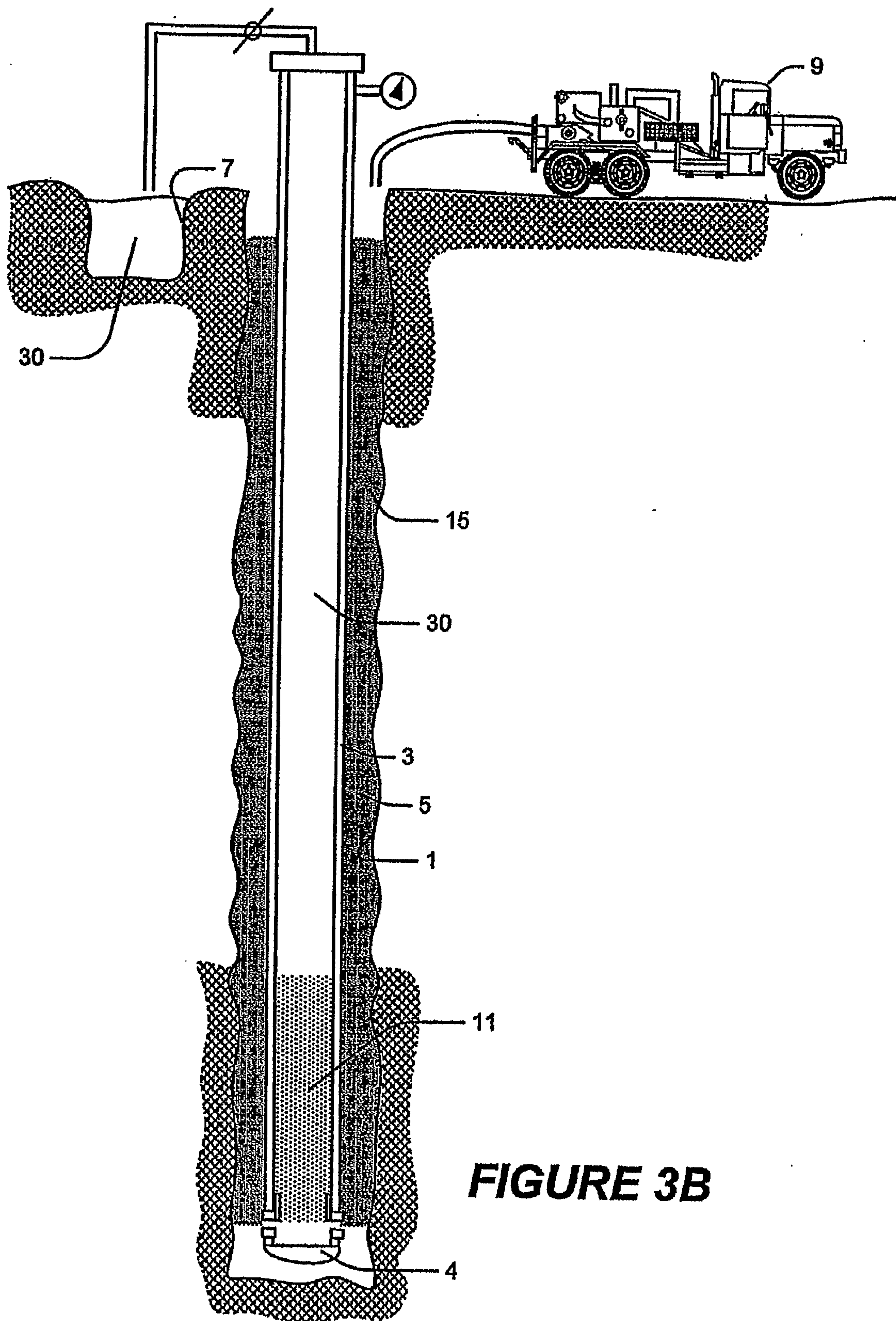

FIGURE 3B

6/7

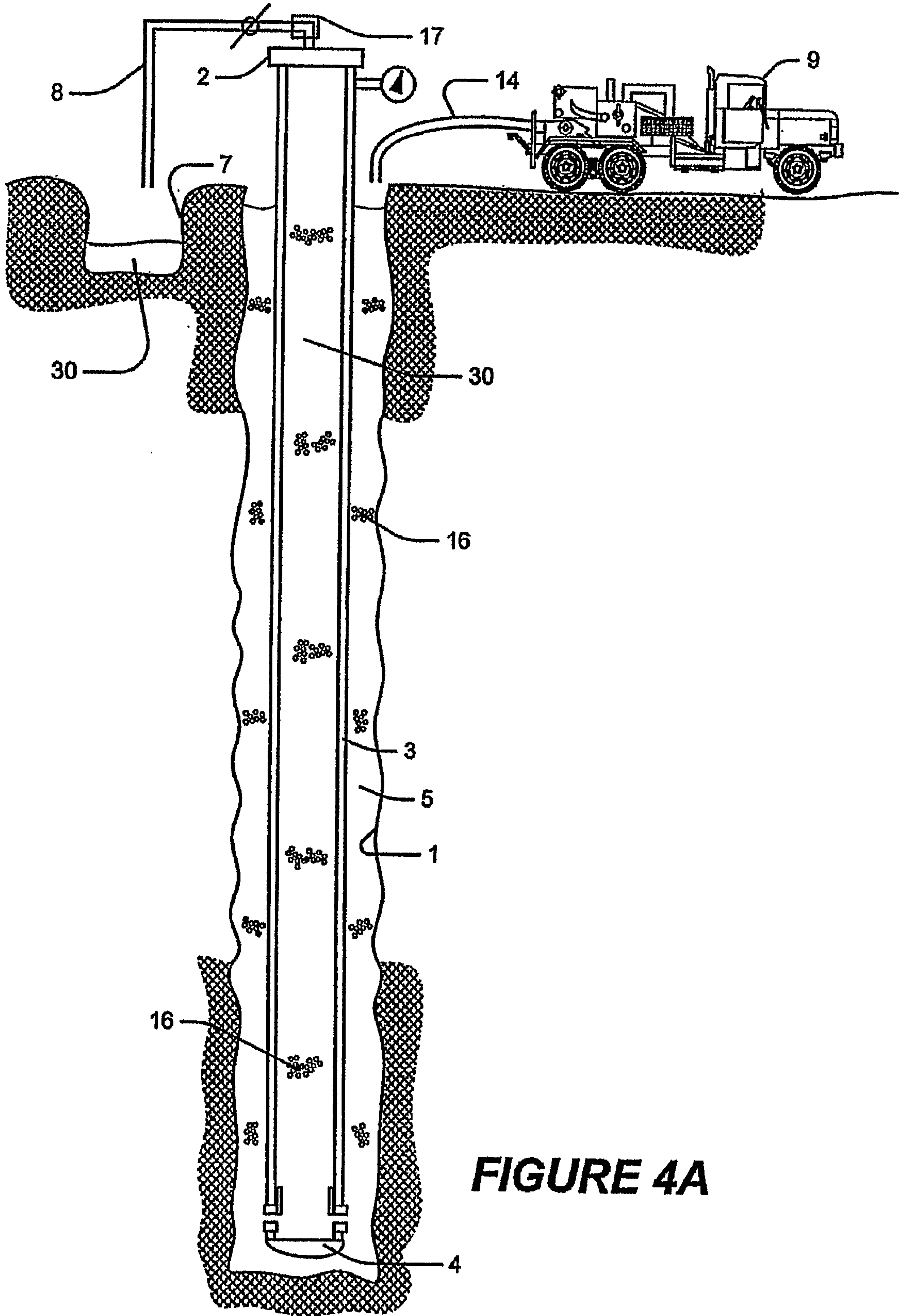

FIGURE 4A

717

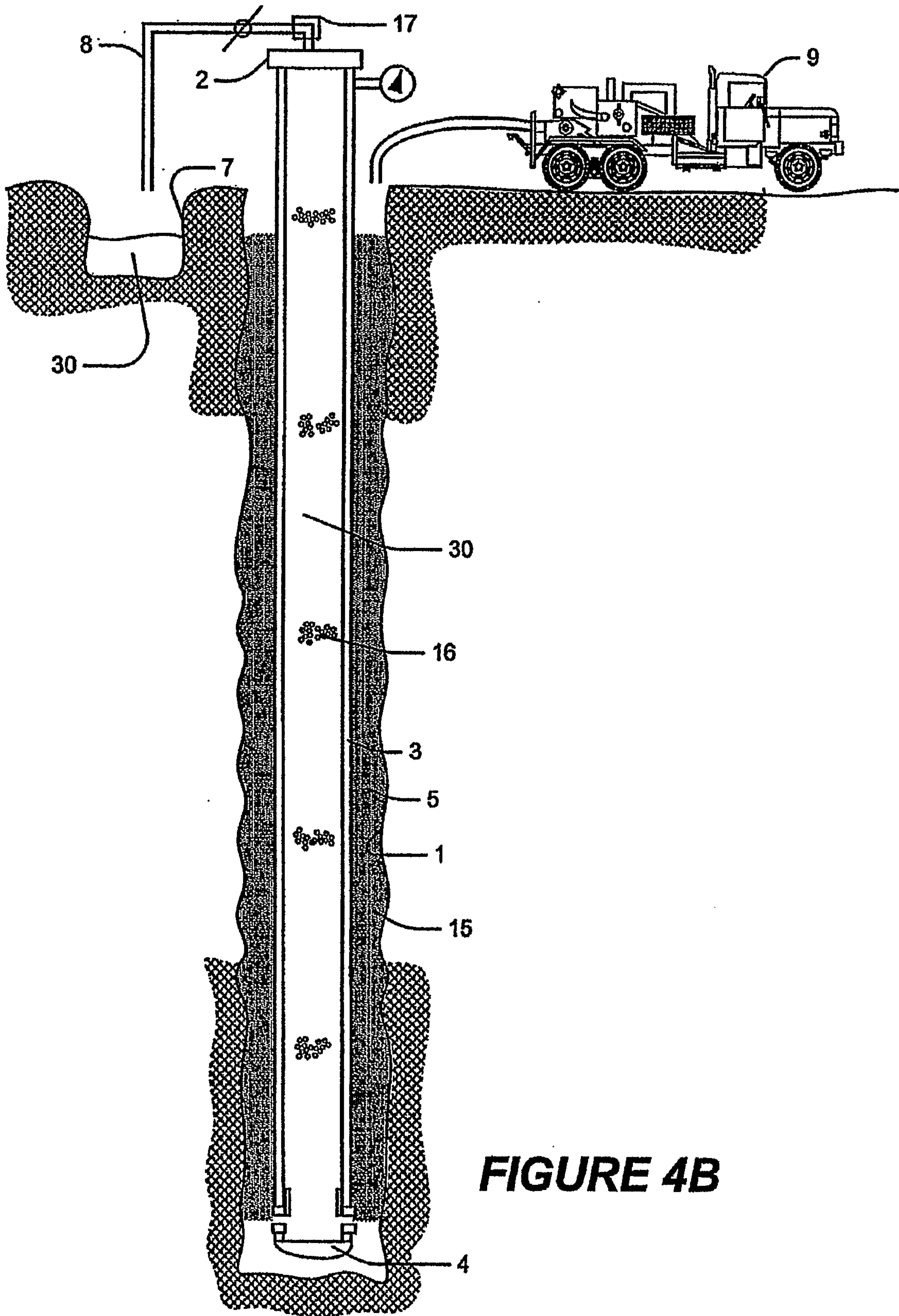

FIGURE 4B

