



US 20080257004A1

(19) **United States**
(12) **Patent Application Publication**
Spaeth

(10) **Pub. No.: US 2008/0257004 A1**
(43) **Pub. Date: Oct. 23, 2008**

(54) **BENDING DEVICE COMPRISING COMPENSATOR ROLLERS**

Publication Classification

(76) Inventor: **Walter Spaeth**, Uberlingen a. Ried (DE)

(51) **Int. Cl.**
B21D 11/08 (2006.01)
B21D 9/04 (2006.01)
(52) **U.S. Cl.** 72/167; 72/369

Correspondence Address:
BROWDY AND NEIMARK, P.L.L.C.
624 NINTH STREET, NW
SUITE 300
WASHINGTON, DC 20001-5303 (US)

(57) **ABSTRACT**

Disclosed is a device for bending open, half-open, and closed hollow profiled members (11'). Said bending device operates with a central roller (3) that rests against the inner surface of the bent profiled member, a milling roller (4) which leans on the outer surface of the bend, and a bending roller (11) located at the discharge end of the profiled member. Said bending roller (11) acts upon the outer surface of the bend, counter to the supporting effect of a support roller (5, 6) that rests against the outer surface of the bend at the feeding end. In order to allow also thin-walled, sensitive profiled members to be shaped, additional milling rollers (12, 13) that act upon the top and bottom sidewall of the profiled member are disposed on a plane extending perpendicular to the bending plane in relation to the opposite central rollers and milling rollers (3, 4).

(21) Appl. No.: **10/587,031**
(22) PCT Filed: **Jan. 11, 2005**
(86) PCT No.: **PCT/EP2005/000161**
§ 371 (c)(1),
(2), (4) Date: **Jan. 9, 2008**

(30) **Foreign Application Priority Data**

Jan. 24, 2004 (DE) 10 2004 003 681.0

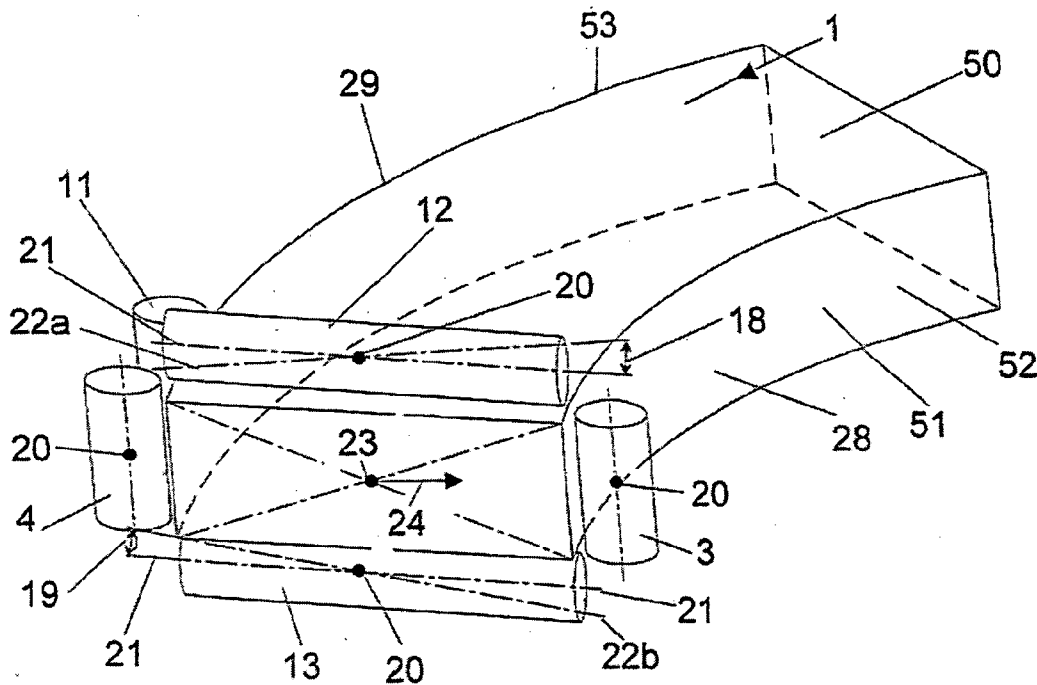

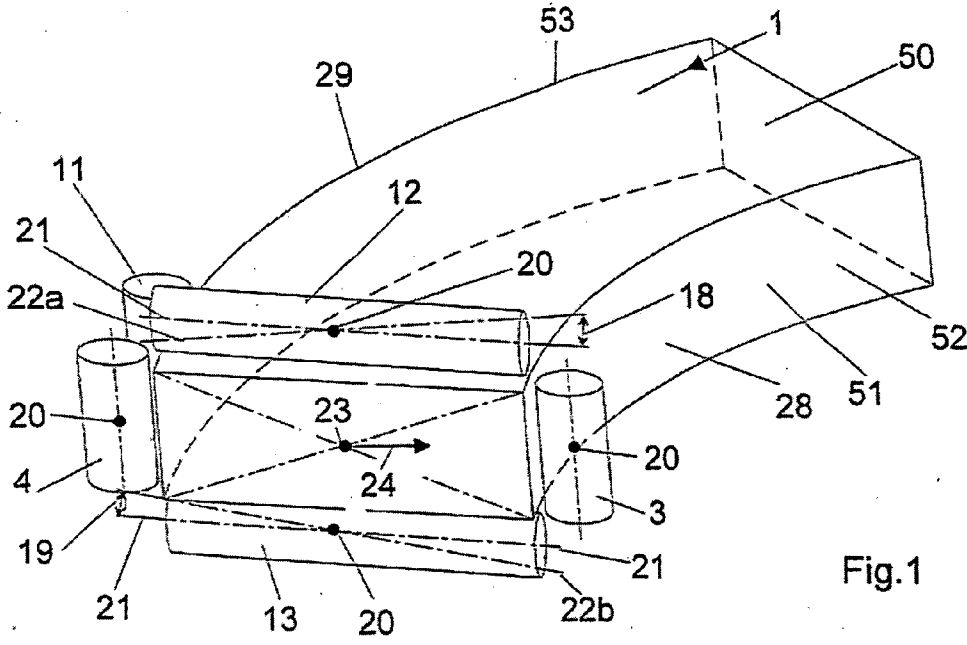

Fig.1

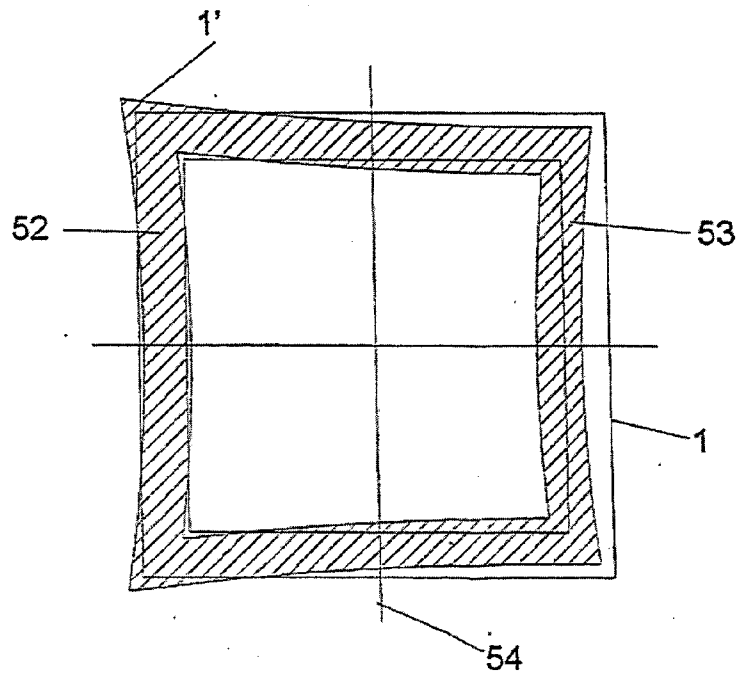

Fig.2

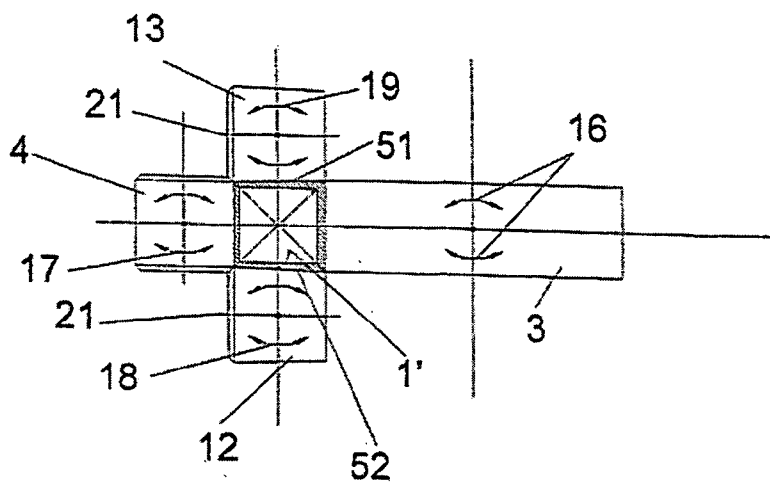

Fig.4

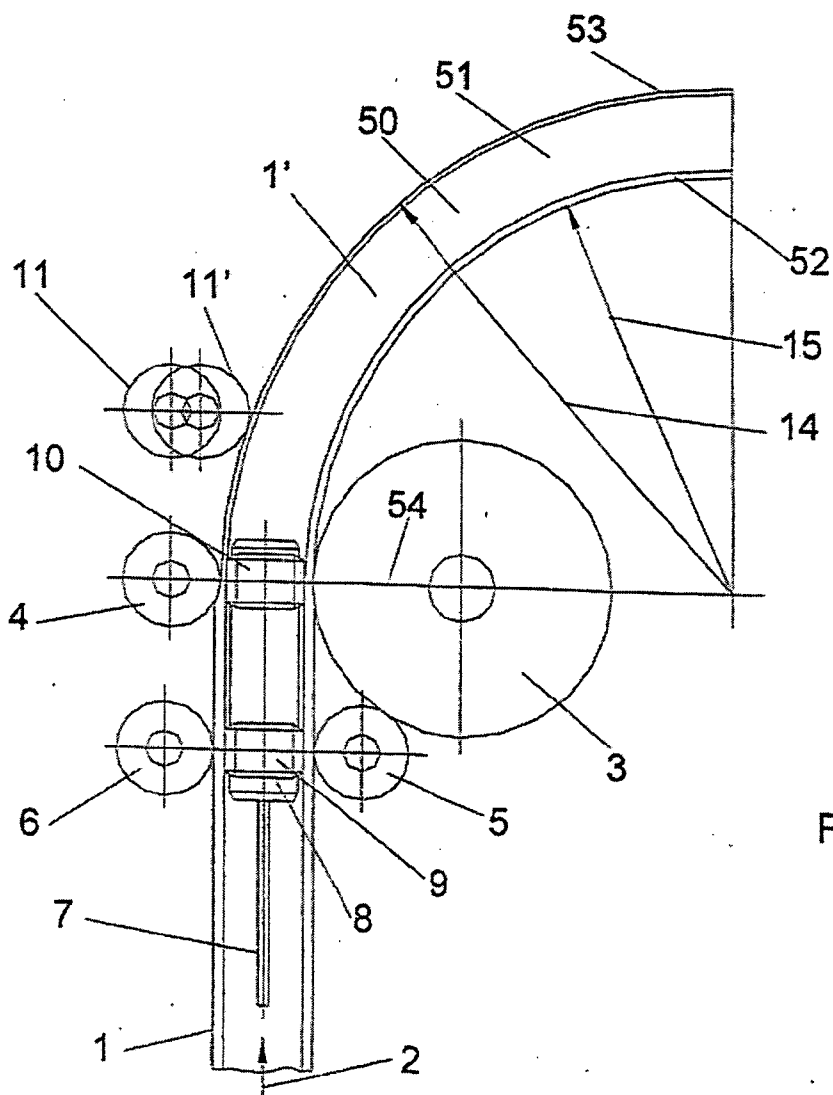

Fig.3

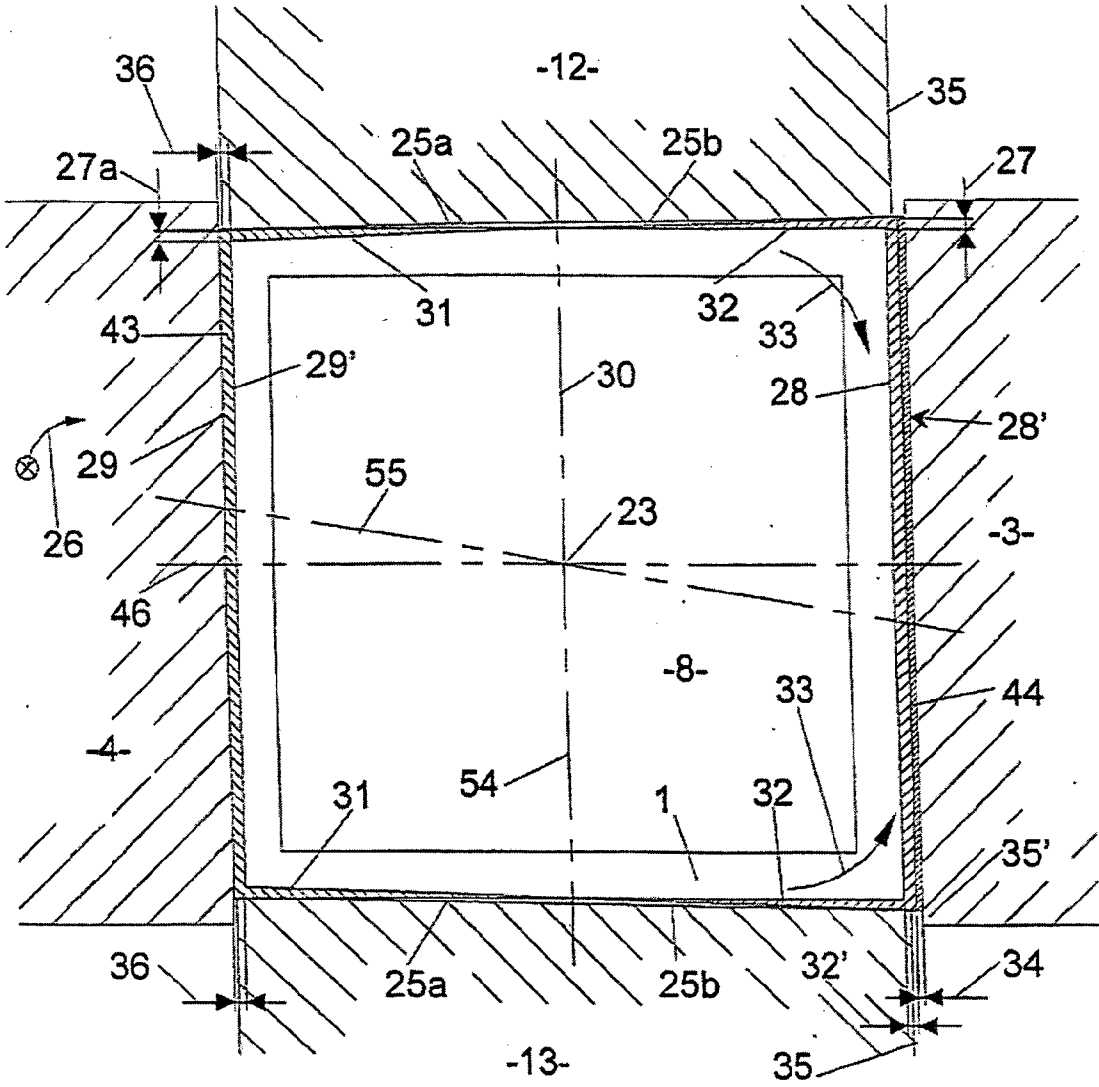

Fig.5

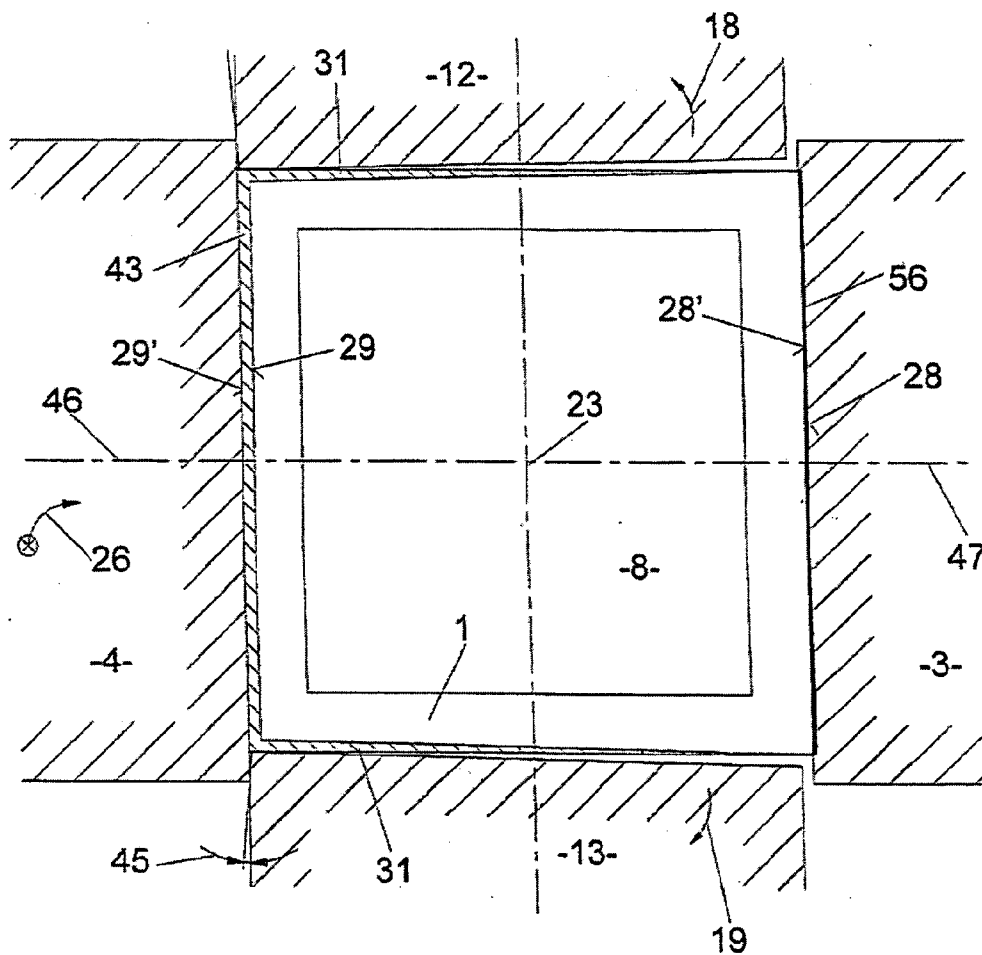

Fig.6

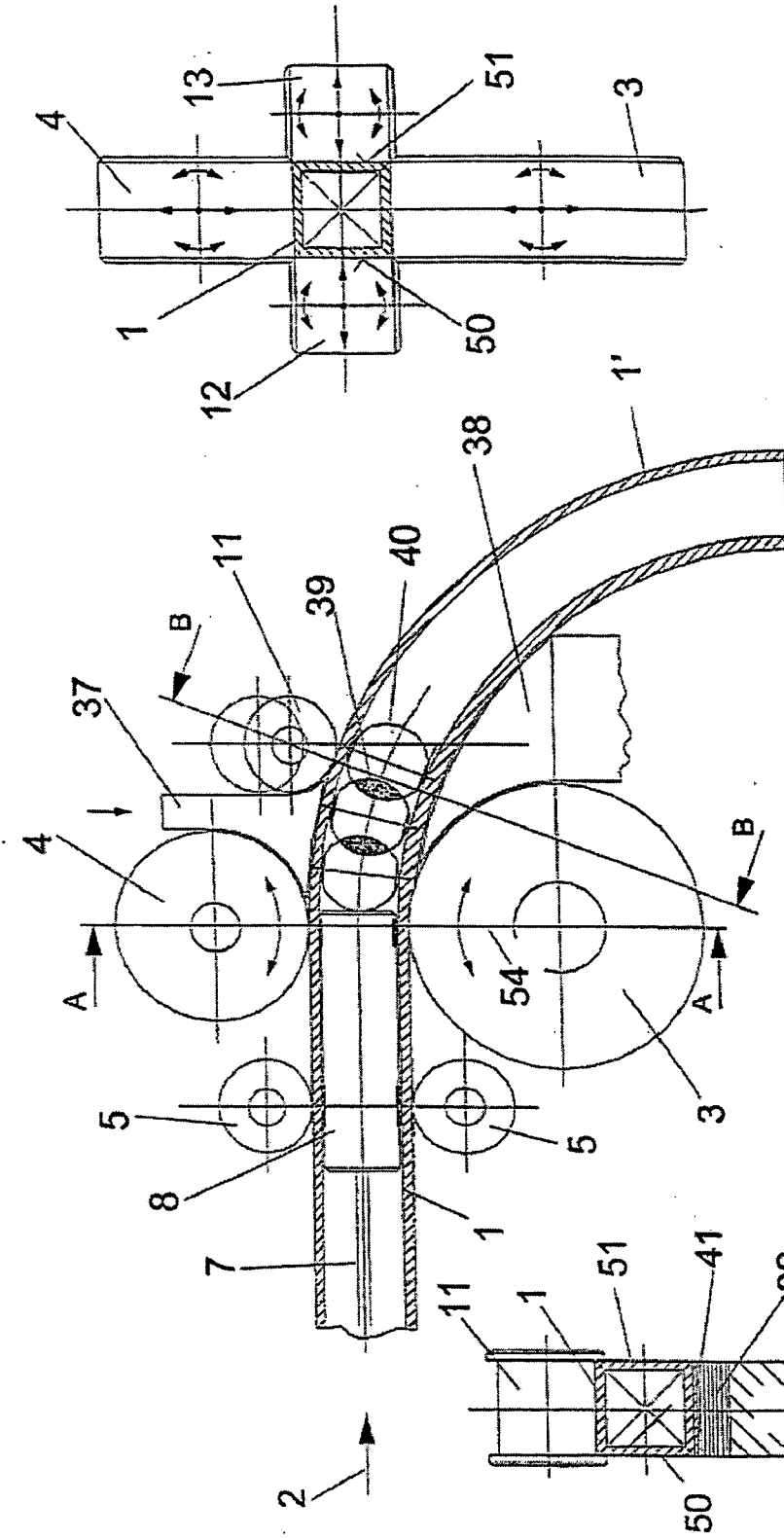

Fig.8

Fig.7

Fig.9

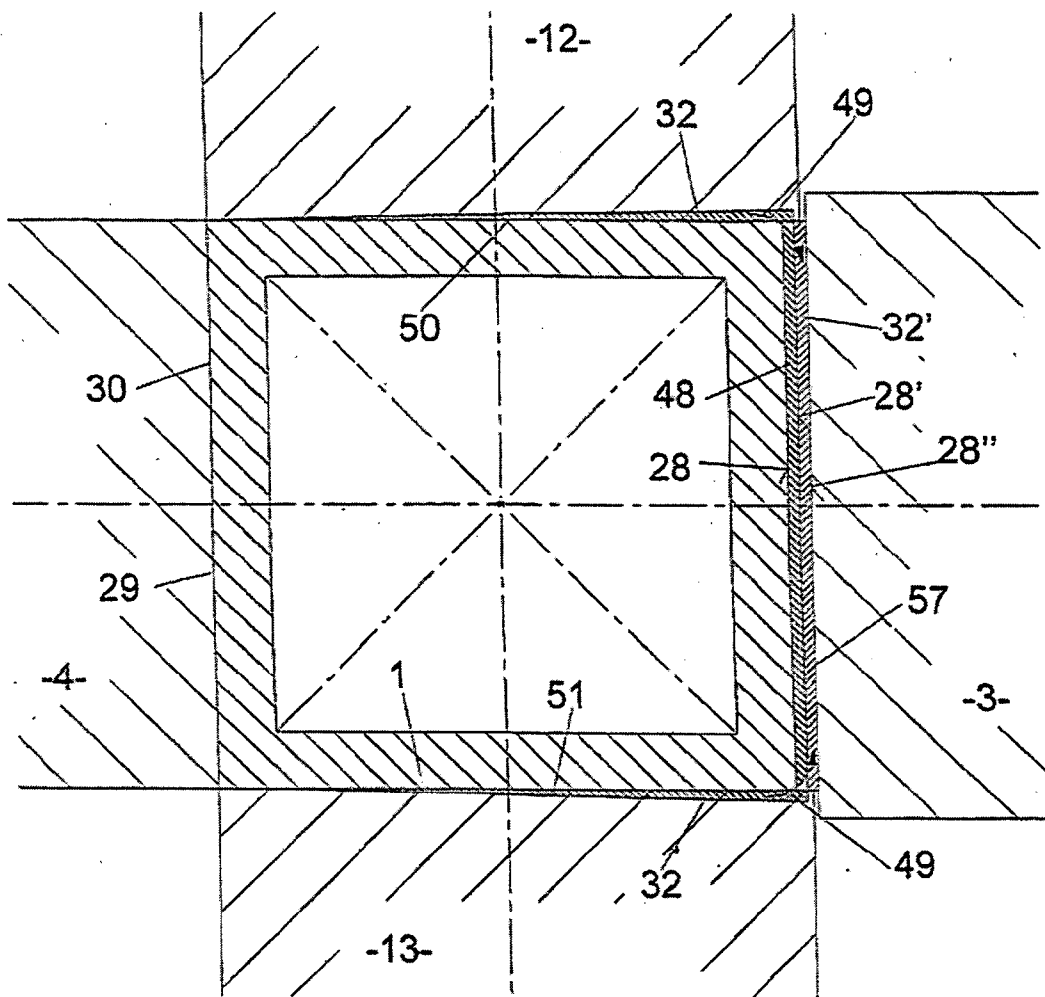

Fig.10

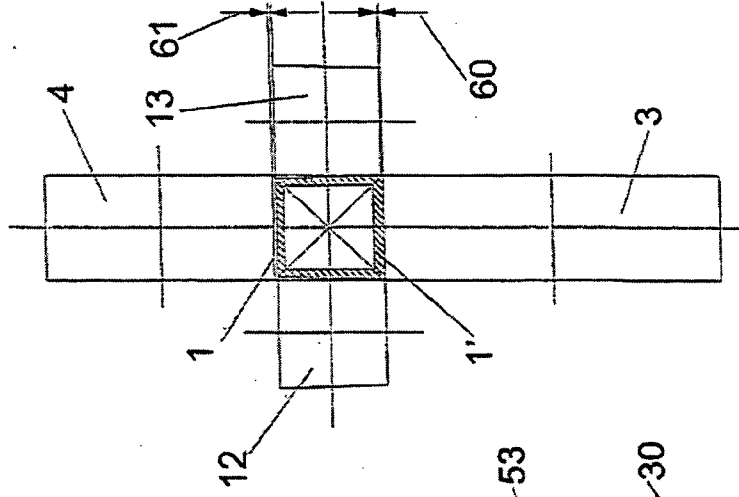

Fig.11

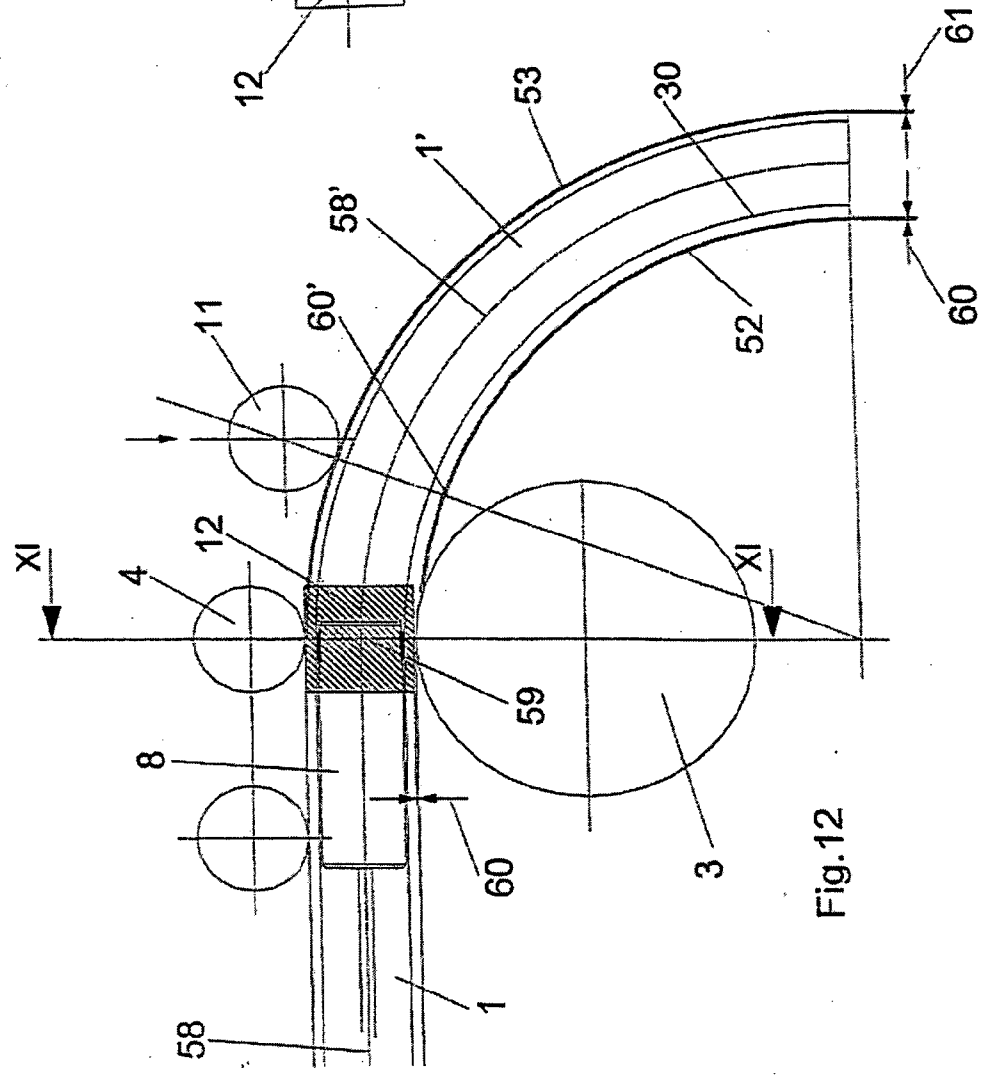

Fig.12

BENDING DEVICE COMPRISING COMPENSATOR ROLLERS

[0001] The invention relates to a bending apparatus comprising oscillating forming rollers according to the precharacterizing portion of claim 1.

[0002] The invention reveals a novel bending process, which will be referred to below also as cold flow forming and bending.

[0003] In the case of cold forming, when bending hollow structural sections, especially open and half-open structural sections, the problem exists that the structural section tends to bulge, buckle, go wavy, or break.

[0004] In DE 197 17 472 A1 a solution for this problem has been proposed in such a way that a four-roller bending machine is provided with a mandrel shank, which is positioned in the interior of the structural section in the bending zone. The bending machine comprises a central roller that rests against the inside of the structural section being bent, a forming roller that rests against the outside of the bend, and a bending roller that is disposed at the outgoing side of the structural section, which acts upon the outside of the bend, namely counter to the supporting effect of a support roller that rests against the outside of the bend at the incoming side.

[0005] It has been found that with this known bending apparatus a roll-down effect of the horizontal sides of the bend (the inside and outside of the bend) of the structural section takes place, namely in such a way that the forming roller that rests against the outside of the bend thins out the structural section in this region and the central roller that rests against the inside of the bend absorbs the reaction forces, which can result in a material increase of the wall thickness in the region of the inside of the bend due to an upsetting effect of the structural section being bent.

[0006] Up to now material changes in the thickness of the material wall of the structural section to be bent, in the region of the inside and outside of the bend used to be accepted without being able to manage these material changes in a controlled manner.

[0007] The associated stretching and upsetting forces on the respective inside and outside of the bend accordingly have a correspondingly negative impact on the shape of the structural section and on the structural constitution of the material.

[0008] The material flow from the outside to the inside of the bend, or toward the outer bend circumference and toward the inner bend circumference, respectively (transverse flow and longitudinal flow of the grain in the cross-sectional profile) therefore could not be influenced in a controlled manner. As a result, bulging and warping was able to occur in the walls.

[0009] When bending this structural section, there accordingly is a stretched region in the extrados and an upset region in the intrados.

[0010] Stretching and upsetting are events that result from the introduction of forces to overcome the resistance moment of a structural section to be bent; these forces cause a grain flow of the material in the structural section to be bent.

[0011] The stretching and upsetting flow is caused by large tensile and pressure forces being created in the outside and inside region of a section bend when its elasticity limit is exceeded.

[0012] In the case of the conventional bending of structural sections according to DE 197 17 472 A1, deformations in the

cross section of the structural section occur in the fringe area of a bend, although, in accordance with the subject of DE 197 17 472 A1, influence was already exerted on this deformation insofar as the inner and outer wall of the structural section were subjected to a clean guidance by means of a mandrel shank positioned in the bending zone.

[0013] It was nonetheless possible for so-called micro-cracks or macro-cracks to occur in the side wall of the structural section being bent, or shear forces in the transition areas between the rolled and unrolled wall, which could result in a separation of the material. The homogeneity of the structure was disturbed or even broken.

[0014] The invention is therefore based on the object of improving a bending apparatus of the above type in such a way that an optimal forming of a structural section is achieved without interfering with the homogeneity of the structure, while preventing micro-cracks or macro-cracks from forming in the side walls of the structural section.

[0015] The purpose of this is to achieve a clean and dimensionally accurate cross-section shape of the structural section being bent, and a clean surface.

[0016] To meet the above object, the invention is characterized by the technical teaching of the claim.

[0017] It is an essential aspect that there are provided in the plane perpendicular to the bending plane, relative to the central and forming rollers that are disposed across from each other, additional so-called oscillating forming rollers, that act upon the upper and lower side wall of the structural section.

[0018] With this technical teaching, a novel flow forming and bending process is proposed, which induces a grain flow in the neutral axis of a structural section. This grain flow is caused by the rolling process at the instant when the bending process is initiated accompanied by application of the rolling effect. Any stretching and upsetting forces are reduced to a minimum in this manner, or eliminated altogether, depending on the rolling force to be applied and the penetration depth of the forming rollers into the material.

[0019] The homogeneity of the stock during the bending process remains largely intact, or it is even improved due to the inventive compression of all walls (outside of the bend, inside of the bend, side wall on top, side wall at bottom).

[0020] The above-mentioned harmful influences in the cross-sectional structural composition in the neutral axis can thus no longer develop.

[0021] The invention accordingly proposes additional rollers that rest against the upper and lower side wall, which will be referred to in the following text as oscillating forming rollers. However, the invention is not limited to the term "oscillating forming roller". In the simplest embodiment of the invention, these forming rollers (with or without contour) are arranged non-oscillating but rigid.

[0022] The invention deals mainly with the induced grain flow, which extends from the outside of the bend of the structural section toward the inside of the bend, and it controls this grain flow by affixing upper and lower oscillating forming rollers at the upper and lower side walls, in order to thus deflect the grain flow from the outside of the bend to the inside of the bend and pass it into said inner bend.

[0023] At the same time, the volume shift effects a longitudinal flow, resulting in a lengthening above the bending line.

[0024] If, for example, an open, half-open or closed hollow structural section is bent two-dimensionally, an arc-shaped profile that lies in the xy-plane is obtained after the bending

process. It is embodied by an outside of the bend and an inside of the bend, wherein the so-called forming roller rests against the outside of the bend while the so-called central roller rests against the inside of the bend.

[0025] In the course of creating such a bend, a lengthening of the structural section occurs on the outside of the bend by the amount $l+\Delta l$, whereas at the inside of the bend, the length l is maintained. This applies for the case in which the bending line is located on the inside of the bend. This means that the entire cross-section of the structural section is rolled out in an upward direction from the inside of the bend.

[0026] As a result, the roll-out action of the forming roller on the outside of the bend causes a lengthening of the material, which is accompanied by a controlled material flow in a lengthwise direction, to thus create the outside of the bend. For reasons of clarity, the two walls (which are usually arranged plane-parallel to each other) against which the forming roller and the central roller rest, will be referred to below as “front walls”. The walls extending perpendicular to the former will be referred to as “side walls”.

[0027] The invention now deals with the material flows that are created in the front wall on the outside of the bend, which, according to the invention, are deflected by the novel oscillating forming rollers—which act upon the side walls—over the respective side walls to the front wall on the inside of the bend.

[0028] In accordance with the invention, upper and lower oscillating forming rollers are now provided, which come to rest in each case against the upper and lower side wall. These absorb the material flow from the inside and outside of the bend and distribute it, depending on the penetration depth and incline of the oscillating forming rollers, into the entire contact surface of the upper and lower side wall.

[0029] As a result, the above-described, disadvantageous structural changes due to stretching forces, shear forces and upsetting forces no longer occur, since a grain flow of the material takes place into the upper and lower side wall, induced by the upper and lower oscillating forming rollers.

[0030] If, for example, the wall thicknesses of a structural section to be bent are identical, appropriate cross-section changes on the basis of the above-described and calculated material shifts on the structural section wall can be used to place the bending line in such a way that the compression region on the inside of the section bend is largely eliminated. As a result, upsetting forces that can cause deformations no longer exist. Such a shifting of the bending line is attained through the roll-out process on the side walls. This process is therefore also called roll-out bending.

[0031] During this roll-out bending, the upper and lower oscillating forming rollers are positioned conically toward each other with respect to their axial position against the plane-parallelism of the structural section to be bent.

[0032] As a result, a greater roll-out depth is achieved on the two upper and lower side walls at the outside of the bend than, by comparison, at the inside of the bend.

[0033] The inclined positioning of the axial position of the two upper and lower oscillating forming rollers is therefore such that the oscillating forming rollers have a relative penetration depth into the material at the upper and lower side wall at the outside of the bend, whereas this penetration depth may taper off adjusted to 0 toward the inside of the bend.

[0034] In this manner it is achieved that even the bending roller, which is actually necessary, can be eliminated and an arc-shaped forming of the structural section already takes

place based only on this inclined positioning of the two oscillating forming rollers in interaction with the horizontal forming roller and central roller. There no longer is a need for an additional bending roller that rests against the outside of the bend of the structural section and shapes this structural section at an axial distance from the above-mentioned central and forming rollers.

[0035] The invention is obviously not limited to the elimination of the bending roller. Provision may also be made for the bending roller to still exist and for the oscillating forming rollers that are provided here according to the invention, which act upon the upper and lower side wall of the structural section, to be provided in addition.

[0036] It is important in this embodiment that the bending line is moved to the inside of the bend and a grain flow from the outside of the bend is induced in this manner toward the inside of the bend. This is achieved by means of differently adjustable longitudinal axial angles of the oscillating forming rollers and their penetration depths into the material to be formed.

[0037] In the case of this roll-out bending process, it is additionally also important that the material shifts that take place on the inside and outside of the bend are taken into account as well. For this purpose, provision is made for the roller (forming roller) at the outside of the bend to be moved plane-parallel (or at an incline) against the outside of the bend of the structural section while the roller (central roller) resting against the inside of the bend is moved plane-parallel or at an incline against the inside of the bend.

[0038] In the process, the penetration depth of the roller (forming roller) resting against the outside of the bend is absorbed by the oscillating forming rollers that are arranged perpendicular to the former and act upon the side walls, and it is deflected into the side walls and routed over the side walls toward the inside of the bend.

[0039] It is important that no gap or free space between the roller (forming roller) located on the outside of the bend and the perpendicularly adjoining oscillating forming roller is created at the structural section to be formed. These rollers should therefore enclose the structural section to be formed in as form-fitting a manner as possible, in order to prevent any lateral yielding, bulging, and the like in this gap region.

[0040] In order to achieve this effect, it is necessary from a machine-construction point of view, to implement the oscillating forming roller displaceable in its longitudinal axis, so that it follows the section to be formed during the bending process.

[0041] This means that only the wall volume ΔV of the front and side walls of the structural section being bent is shifted from the outside of the bend toward the inside of the bend with decreasing ΔV to an increase in length. This ensures that accumulations of material no longer occur on the inside of the bend, but that these material changes of the outside of the bend ΔV_{\max} are instead transformed toward the inside of the bend ΔV_{\min} into a corresponding increase in length.

[0042] The invention is not limited, in the case of the so-called roll-out bending, to only the oscillating rollers that rest against the side walls being positioned conically inclined toward each other. It may also be provided in an additional embodiment in the case of certain structural section shapes and special wall thicknesses, that the forming and central rollers that rest against the inside and outside of the bend are

implemented correspondingly oscillating and can accordingly also be positioned toward each other at an incline.

[0043] If, in case of a roll-out bending process, one has different wall thicknesses in the structural section that is to be bent, it is advantageous to also position at an incline (to slant) with different penetration depths into the structural section, the forming rollers and central rollers that rest against the inside and outside of the bend.

[0044] In the text that follows the so-called gravity bending will be presented as a second embodiment of the inventive teaching.

[0045] In the case of this gravity bending process the bending line remains in the gravity line, i.e., approximately in the center of the structural section to be bent, provided that the section is symmetrical.

[0046] It is important in the case of this gravity bending process that the upper and lower oscillating forming rollers that rest against the upper and lower side walls can either be positioned slanted toward each other in an oscillating manner, or that they have a double-conical roller surface

[0047] Gravity bending describes a bending condition in which the structural section is subjected to a thinning and lengthening of the wall thickness over the neutral line, i.e., the gravity line, in the region of the outside of the bend by means of a stretching beyond the gravity line.

[0048] At the point of the gravity line the wall thickness starts to increase with the same volume that is displaced from the gravity line to the outside of the bend.

[0049] In other words:

[0050] 1. What decreases in volume on the outside, increases in volume on the inside.

[0051] 2. What increases in length on the outside, decreases in length on the inside.

[0052] This rule applies to a structural section that is shaped symmetrically with respect to its cross-section and walls.

[0053] This physical process also produces a reduction in layout, even though minimal, due to the gravity line being displaced inward.

[0054] The gravity line, i.e., the center of gravity, is shifted by the measure X toward the inside of the bend; caused by the material volume shift.

[0055] The inside cross section of the structural section remains largely intact because of the mandrel shank tool.

[0056] This realization forms the basis for the volume calculation for determining the various roller penetration depths at the section walls and the radii of a structural section to be bent, which, as a result, can be adjusted in a controlled manner.

[0057] The oscillating forming rollers are now adjusted in the front and side wall region in correspondence with the above physical shifting phenomena and the volume changes calculated therefrom.

[0058] The thinning in the region of the outside of the bend, the thickening in the region of the inside of the bend, as well as the conical side wall change are now rolled out in a targeted manner based on a dimensionally accurate setting of the oscillating forming rollers.

[0059] Gravity bending has the following advantages:

[0060] 1. A highly ductile structural constitution (i.e., no distortions, micro-cracks or macro-cracks in the structure)

[0061] 2. Clean outer and inner contour of the cross section of the structural section (i.e., no warping, bulges, waviness in the section wall)

[0062] 3. High dimensional accuracy of the bend and cross-section of the structural section.

[0063] 4. Improved surface consistency of the structural section after the bending.

[0064] 5. Higher bending performance.

[0065] 6. Parts to be bent are bent in a single operation.

[0066] 7. Freely selectable bending contour.

[0067] 8. Smallest possible radii and curves are bent using a single bending tool.

[0068] As a result of the upsetting forces, an increase in material occurs from the center bending line of the structural section toward the inside of the bend in the same volume as the decrease in material on the outside of the bend.

[0069] As the third embodiment of the invention, the so-called roller upset bending will be described in more detail. In this case there are again provided upper and lower oscillating forming rollers, in combination with a bending roller that is disposed axially offset relative to the above-mentioned rollers.

[0070] The bending line, in this case, is moved to the outside of the bend and the conical material thickening of the side walls are deflected into the inner wall of the bend. The main upsetting forces are generated at the inner wall of the bend through shortening of the bend layout.

[0071] Roller upset bending uses decelerated opposed central and forming rollers, i.e., the speed of the respective roller resting against the outside and inside of the structural section is less than the speed of the structural section through the bending gap. Additionally arranged at the inside and outside of the bend are so-called brake-shoes that increase the resistance on the structural section to be bent, and a strong upsetting effect is thus created in the neutral axis.

[0072] Generally, all three bending methods are based on the realization that a disturbance of the structural composition is prevented through symmetrical or asymmetrical volume shifts of the cross section of a structural section by means of oscillating forming rollers that rest against the upper and lower side walls.

[0073] The internal geometry (i.e., the interior cross-sectional shape) of a structural section remains dimensionally unchanged.

[0074] It is important that the internal dimensions of the structural section are maintained and only the outside dimensions of the section are changed in the sense of a volume shift. The internal dimensions of the section remain constant in this case.

[0075] Alternatively, the following text describes as an additional possibility that the exterior dimensions of the structural section remain constant. This is achieved with a flexible adjustable mandrel shank, which absorbs the wall thickness changes that occur in the interior of the section. From the outside it is therefore not apparent from the bent structural section that it has differently rolled-out wall-thicknesses in the bent inside region.

[0076] The bending line, in this case, is the line at which the forces for the stretching and upsetting build up and form the respective structural section.

[0077] In this context it is important for the invention with respect to all embodiments that the present invention is directed not only to a two-dimensional forming of a section, but that it can additionally also be achieved through the arrangement of either contoured or oscillating forming rollers that a spiral can be bent (in three-dimensional shape) from a two-dimensional section. In the case of the spiral-bending

process, the bending roller and also the other known auxiliary means may even be eliminated, as this spiral shape is attained simply as a result of the volume shifting (due to the oscillating forming rollers).

[0078] This is achieved by means of a conical inclined positioning of the center roller and the opposed forming roller.

[0079] To achieve this effect, the upper and lower oscillating forming rollers still serve to create the desired grain flow and radius of the bend.

[0080] The object of the present invention is derived not only from the subject matter of the individual claims, but also from the combination of the individual claims among each other.

[0081] All disclosed information and features contained in the documentation, including in the abstract, especially the three-dimensional design depicted in the drawings, are claimed as essential to the invention to the extent that they are novel with respect to the prior art, either individually or combined.

[0082] In the text that follows the invention will be explained in greater detail based on drawings depicting a number of possible embodiments. Additional characteristics and advantages of the invention that are essential to the invention will become apparent from the drawings and from their description.

[0083] The figures show as follows:

[0084] FIG. 1: in a schematic illustration, the bending of a two-dimensional structural section;

[0085] FIG. 2: the deformation of a structural section in the bending process according to FIG. 1 if a mandrel shank that is moved along in the bending zone is dispensed with;

[0086] FIG. 3: a schematic top view of a bending apparatus in a first embodiment;

[0087] FIG. 4: a section along line A-A in FIG. 3;

[0088] FIG. 5: the enlarged depiction of the profile to be bent under the effect of the rollers in the gravity bending process;

[0089] FIG. 6: the enlarged depiction of the section to be bent under the effect of the various rollers in the roll-out bending process;

[0090] FIG. 7: the second embodiment of a bending apparatus in the top view;

[0091] FIG. 8: a section along line A-A in FIG. 7;

[0092] FIG. 9: a section along line B-B in FIG. 7;

[0093] FIG. 10: an enlarged depiction of a section to be bent in the roller upset bending process using an apparatus according to FIGS. 7 through 9;

[0094] FIG. 11: a section through the roll bending zone of the structural section with the four rollers resting against it;

[0095] FIG. 12: a schematic depiction of the processes during the forming operations, shown in a sectional view.

[0096] In FIG. 1, a symmetrical hollow section (referred to as structural section 1) is formed into a curved structural section by means of a symmetrical forming and bending.

[0097] For simplification purposes it is not shown that additional support rollers 5, 6 according to FIG. 3 are disposed at the incoming side of the structural section 1.

[0098] An important aspect in the comparison of FIG. 1 to FIG. 3 is that a forming roller 4 rests against the outside of the bend (outer front wall), while a central roller 3 rests against the inside of the bend (inner front wall). The two rollers are either both driven rotationally or only one of them is driven rotationally.

[0099] Extending inside the interior of the hollow section is a mandrel rod 7, at the front end of which a mandrel shank 8 is disposed, which has corresponding support elements 9, 10.

[0100] These support elements 9, 10 are highly wear-resistant support members that come to rest against the interior of the structural section 1 in the region of the bending zone.

[0101] The bending zone, in this case, is created by the arrangement of the central rollers 3 and 4 across from each other.

[0102] In other respects, the structural section may also be pushed through the bending zone in the direction of the arrow 2 by means of a sliding device that is not shown in detail.

[0103] FIG. 1 shows that the forming roller 4 rests against the outside 53 of the bend, whereas the central roller rests against the inside 52 of the bend. In this manner it is achieved, for example, that the inside of the bend is bent with a bending radius 15, while the outside 53 of the bend is bent with a bending radius 14.

[0104] In order to make the bending feasible in the first place, a bending roller 11 is disposed at the outside 53 of the bend at an axial distance from the bending zone, said bending roller 11 being shiftable as illustrated into the position 11' in order to thus act with an advancable force upon the outside 53 of the bend of the structural section to be bent.

[0105] The bending roller 11, in principle, acts against the resistance of the support rollers 5, 6, especially that of the support roller 6, whereas the support roller 5 has only guiding functions.

[0106] In accordance with the invention, provision is now made for an upper oscillating forming roller 12 to rest against the upper side wall 50 in a forming manner, while a lower oscillating forming roller 13 is in forming contact with the lower side wall 51.

[0107] This is novel and has not yet been described in the prior art.

[0108] The arrangement of the upper and lower oscillating forming rollers 12, 13 is also shown schematically in FIG. 1.

[0109] In accordance with the invention, provision is now made in a first embodiment for these two oscillating forming rollers 12, 13 to be designed oscillating with respect to their axial position (relative to the horizontal axis 21), i.e., the upper oscillating forming roller 12 can be swiveled in the direction of the arrow 18 to the swivel axis 22a, and the lower oscillating forming roller 13 can be swiveled in the direction of the arrow 19 to the lower swivel axis 22b.

[0110] This clarifies that the two oscillating forming rollers 12, 13 are positioned conically toward each other and that they have a greater penetration depth in this case onto the given side wall 50, 51 at the outside 53 of the bend than, by comparison, onto the side wall 50, 51 toward the inside 52 of the bend.

[0111] Rather, provision is made in a preferred embodiment for the penetration depth to be maximal at the outside 53 of the bend, whereas it tapers off toward 0 at the inside 52 of the bend.

[0112] In a further development of the invention, it is provided that not only the oscillating forming rollers 12, 13 that are assigned to the upper and lower side walls 50, 51, are designed swiveling and inclineable, but that, additionally, the forming roller 4 and/or the central roller 3 are also designed swiveling. A swiveling movement of this type may take place in this case in the directions of the arrows 16, 17.

[0113] In the example embodiment according to FIGS. 1 and 4, the upper oscillating forming roller 12 is thus swiveled

in a clockwise direction according to the direction of the arrow **18** against the upper side wall **50**, whereas the lower oscillating forming roller **13** is swiveled in a counter-clockwise direction (direction of the arrow **19**) against the corresponding side wall **51**.

[0114] FIG. **2** now shows that when the structural section is formed under removal of the corresponding guide means, a structural section **1** turns into the undesirably deformed structural section **1'**, which experiences, on the outside **53** of the bend, a corresponding denting with a corresponding shortening of the width dimensions, while a thinning of the material occurs at the same time.

[0115] An increase in material must be imagined on the inside **52** of the bend in such a way that this increase is distributed in the form of a corresponding denting and increase in wall thickness.

[0116] This phenomenon occurs especially in cases when no mandrel shank **8** is moved along in the interior of the structural section and stretching forces on the outside and upsetting forces on the inside cause a deformation of the structural section in the depicted form.

[0117] In accordance with the invention, provision is now made according to FIG. **4** for the oscillating forming rollers **12**, **13** that rest against the side walls **50**, **51**, to be moved in each case with the roller force F_2 and F_3 against the side wall **50**, **51**, and at the same time to be swiveled toward each other in the directions of the arrows **18**, **19**.

[0118] In the case of the roll-out bending, the result is therefore a conical side wall profile of the bent structural section **1'**, as it is depicted in FIG. **1**.

[0119] A thickening of the cross-section of the structural section takes place in the region of the central roller **3** at the inside of the bend, whereas in the region of the outside of the bend a thinning of the structural section takes place. In the side wall region of the side walls **50**, **51**, the material is distributed conically.

[0120] FIG. **5** shows the forming of the structural section in an enlarged scale in the case of the gravity bending process.

[0121] The respective rollers **3**, **4**, **12**, **13**, are shown only schematically in this case, and only in the region of their roller surfaces in their action upon the respective outsides of the structural section **1** being formed.

[0122] The translation of the drawing FIG. **5** to drawing FIG. **1** means that the section is bend upward, quasi out from the drawing plane of FIG. **5**, into the direction of the arrow **26**.

[0123] It is important in this context that the forming roller **4** is moved in the direction of the arrow **46** (advancing direction) into the extrados **29**. The neutral axis **54** extends through the zero-line **30**. The previous, unformed extrados **29** is transformed into the formed extrados **29'**. This involves a material thinning **43**. The material thinning **43** results from the difference between the unformed extrados **29** and the post-bending extrados **29'**. The stretching forces that are created during the forming process lead to said material thinning **43**.

[0124] In the region of the side wall, where the corresponding oscillating forming rollers **12**, **13** exert their action, a conical material thinning **31** results, which is depicted as thin, wedge-shaped areas **31** that extend perpendicularly from the vertical material thinning **43** at the outside of the bend toward the inside of the bend.

[0125] At the neutral axis **54** in the region of the zero-line **30** this wedge-shaped material thinning **31** disappears.

[0126] On the other side of the bending line **30** toward the intrados **28**, a material increase is produced again, which

increases, starting as a narrow, wedge-shaped wedge, from the bending line **30** toward the inside **52** of the bend.

[0127] In the process, an identical volume exchange takes place between the material thinning **31** and the material increase **32**.

[0128] It is now important that the respective oscillating forming rollers **12**, **13** have a specially contoured roller surface and that they are not themselves movable against the respective side walls in an oscillating or inclined manner.

[0129] The roller surface **25** of the respective oscillating forming roller **12**, **13** is slanted in such a way that the roller surface portion **25a** rises conically, starting from the bending line **30** to the extrados **29**. This achieves a maximum penetration depth of the oscillating forming roller **12**, **13** acting in the extrados. This penetration depth enhances the lengthening of the bend, i.e., the increase in length on the outside **53** of the bend.

[0130] To the right of the bending line **30**, toward the inside **52** of the bend or toward the intrados **28**, respectively, however, the roller surface **25b** of the respective oscillating forming roller **12**, **13** is designed exactly cylindrical. This has the result that the material increase **32** occurring in the side wall region **50**, **51**, is deflected in conical form in the direction of the arrow **33** into the intrados **28**. This is the result of the given oscillating forming rollers **12**, **13**, being positioned symmetrically and not inclined against the respective side wall **50**, **51**, causing the material increase **32** to be displaced in the direction of the arrow **33** into the intrados **28** where it assumes the later intrados shape **28'**.

[0131] As a result, a material increase **32'** occurs on the inside **52** of the bend, so that the degree of thinning **36** that exists to the left at the forming roller **4** is thus shifted via the oscillating forming rollers **12**, **13** to the right toward the inside of the bend, namely onto the line of material increase **32'**.

[0132] As a result of the conical material additions of the material increases **32**, a material thickening **34** is produced in the region of the inside wall of the intrados **28**.

[0133] The central roller **3** has a shaping character only in such a way that the shape of the inside **52** of the bend is supported correspondingly.

[0134] The material increase **44** that is produced in the process results from the volume shift from the two wedges of the material increase **32** created in the side wall.

[0135] The forces that are generated through stretching and upsetting are equal, however with opposite operational signs. This is symbolized by the slope, which indicates that the forces in the region of the center axis **23** and neutral axis **54** are at 0, whereas in the region of the extrados **29**, they are shown with minus.

[0136] Decreasing means they are shown on the intrados **28** with plus and are, therefore, maximal.

[0137] On the extrados, a stretching force is therefore created, whereas a compression force is generated on the intrados.

[0138] The thinning **27a** that is created on the extrados **29** is accordingly converted into a¹ on the intrados **28** in the same volume into the compression thickness **27**.

Translator's note: This translation is based on an incomplete German sentence.

[0139] Reference numeral **35** marks the lateral demarcation of the roller surface **35** of the oscillating forming roller, which is displaced by the movement of the forming roller to the roller surface **35'**.

[0140] FIG. **6** describes a setup for the roll-out forming process.

[0141] In this setup it is essential that the oscillating forming rollers 12, 13 do not have any specially contoured roller surface 25 but that the oscillating forming rollers 12, 13, are inclined altogether by an angle 45 (angle α), namely starting from the extrados 29 extending toward the intrados 28.

[0142] The bending line now shifts from the center of gravity in the center axis 23 toward the bending line 30 onto the intrados 28.

[0143] In the case of the roll-out bending it is important that a bending roller 11 is not necessarily required, but that the form bending takes place only via the conical positioning of the oscillating forming rollers 12, 13, with the aid of advancing the forming roller 4 and central roller 3.

[0144] In the process, the central roller 4 is moved in the direction of the arrow 36 (advancing direction) against the extrados 29, which results in a material thinning 43 and this material thinning 43 is converted into an increase in length on the extrados 29.

[0145] At the same time the material thinning 43 in the region of the side walls is converted into a material thinning 31 that extends in a wedge shape, said material thinning tapering off toward 0 toward the inside of the bend at the intrados 28.

[0146] In the case of this roll-out bending, the bending line 30 is located on the inside of the bend of the intrados 28.

[0147] It is important in this context that the two oscillating forming rollers 12, 13, are inclined toward each other in the directions of the arrows 18, 19, with the penetration depth on the left onto the structural section corresponding to the material thinning 43. All three roll-out actions, namely the roll-out process with the forming roller 4 and with the oscillating forming rollers 12, 13, take place at the same time.

[0148] For this reason a material increase 56 is generated on the inside of the bend.

[0149] The surface pressure of the forming roller 4 onto the extrados 29 is approximately 3 times greater than, by comparison, the surface pressure of the central roller 3 that rests against the intrados 28. This results in a penetration depth of e.g., 4 mm in the region of the extrados 29 and a penetration depth of 1.3 mm in the region of the intrados 28 for the respective rollers 4, 3.

[0150] The example embodiment according to FIG. 6 is thus characterized in that that the upper oscillating forming roller 12 is positioned conically inclined relative to the lower oscillating forming roller 13, so that a greater penetration depth of these two oscillating forming rollers 12, 14 occurs at the extrados 29 than, by comparison, at the intrados 28.

[0151] At the intrados 28 the penetration depth is 0 at the point where the bending line 30 extends.

[0152] The entire bending action takes place in the neutral axis 54. In all three example embodiments it is also important that the interior of the structural section 1, 1' is always stabilized in this neutral axis 54 by means of the mandrel shank 8, which is held there precisely positioned, in order to thus always uphold the interior dimensions of the structural section 1 in a stable manner. The force of action of the forming roller 4 is accordingly transferred to the central roller via the structural section and via the mandrel shank 8 that is held in the interior of the structural section.

[0153] According to the invention the oscillating forming rollers 12, 13 are likewise positioned against the corresponding side walls 50, 51 of the structural section with an adjustable positioning force, said positioning force being in the range of 100 kN.

[0154] The positioning force of the forming roller 4 onto the extrados 29 could be in the range of 400 kN, whereas the central roller 3 experiences only a reaction force. The central roller, in this case, absorbs altogether 800 kN.

[0155] The reason being that the forming roller 4 exerts 400 kN, the bending roller 11, which is not shown, applies 200 kN onto the structural section, and a reaction force onto the support roller 4, 5, is created in the process. Additionally, corresponding action forces of 100 kN in are created each case at the oscillating forming rollers 12, 13, so that the central roller 3 absorbs altogether 800 kN; the action forces of the oscillating forming rollers 12, 13 having no impact on the central roller 3.

[0156] FIG. 7 shows a second example embodiment of a roller bending machine incorporating oscillating forming rollers, which describes the roller upset bending process.

[0157] The same apparatus is used in this case as was explained above based on FIG. 3. The explanations listed there, therefore also apply to FIG. 7.

[0158] However, FIG. 7 additionally shows that a link chain 39, which links individual roller elements 40 in an articulated manner, is disposed at the free frontal end of the mandrel shank 8.

[0159] It is ensured in this context that the roller elements 40 are arranged in the region of the neutral axis 54 and behind the neutral axis 54 in the discharge direction, in order to additionally support the interior cross section of the structural section 1'.

[0160] A strong upsetting force is caused by the fact that that the structural section is pushed into the bending zone in the direction of the arrow 2, and the speed at which the central roller 3 and the forming roller 4 drive the structural section 1 is less than the thrust speed in the direction of the arrow 2. This creates an upsetting effect on the structural section 1 that is additionally enhanced by two brake shoes 37, 38 located across from each other.

[0161] The brake shoe 37 rests against the outside 53 of the bend, whereas the brake shoe 38 rests against the inside 52 of the bend.

[0162] FIG. 8 additionally shows that not only the oscillating forming rollers 12, 13 are designed swiveling, but that it is additionally possible to design the central roller 3 and forming roller 4 swiveling as well. These rollers 3, 4 are designed swiveling in those cases when not only a two-dimensional bending of the structural section 1 is required, but when this structural section is to be bent in a spiral shape. This is symbolized by the directions of the arrows in FIG. 8.

[0163] FIG. 9 shows a section in the direction of the line B-B in FIG. 7, where it is apparent that the brake shoe rests against the inside 52 of the bend in a friction-increasing manner, and achieves a strong upsetting effect in the process.

[0164] In the above-described manner the upper oscillating forming roller 12 rests against the upper side wall 50, while the lower oscillating forming roller 13 according to FIG. 8 rests against the lower side wall 51.

[0165] Characterizing for this example embodiment is that the bending line 30 has now been moved onto the extrados 29. The bending line 30 in this context is understood to mean that no force acts upon the structural section 1 in this region. It is therefore a neutral line.

[0166] The compression onto the side walls 50, 51 toward the intrados 28 now starts from this bending line 30 at the extrados 29, with a conical material increase 32 resulting in the region of these side walls.

[0167] The oscillating forming rollers 12, 13 have a straight cylindrical roller surface and they are oriented plane-parallel to the original unformed structural section 1.

[0168] During the bending process the wedge-shaped material increase 32 is produced and at the same moment this excess material 32 is rerouted, with the oscillating forming rollers held unchanged in the same position, into the region of the inside 52 of the bend, where an additional material increase 48 is produced at the intrados 28.

[0169] The previous unformed intrados 28 moves radially outward toward the intrados 28', as shown in FIG. 10.

[0170] If one were to leave the cone 32 in the region of the side walls 51, 52, only this material increase 48 would occur. If, however, this material 32 is displaced from the side walls into the inside region of the bend, an additional material increase 32' results.

[0171] When these two wedges of the material increase 32 in the region of the side walls 50, 51 are placed on top of one another, this volume corresponds exactly to the volume of the material increase 32' in the region of the intrados 28'.

[0172] The roller surface 57 of the central roller has a forming character, only with respect to forming the enlarged intrados 28".

[0173] The material increase 48, 32' on the intrados 28 does not interfere with the use of a structural section of this type.

[0174] As a result of the forced forming and roll-out effect by the oscillating forming rollers 12, 13, however, the conical material increase 32 in the side walls is displaced inward, so that the side walls 50, 51 of the formed profile 1 maintain their absolute plane-parallelism.

[0175] The layout of a bend is generally always measured starting from a bending line 30, which, in the depicted example embodiment, is located on the outside 29 of the bend.

[0176] A material roll-down effect does not occur at the outside of the bend (extrados 29) and the material displacement phenomena are displaced over the side walls 15, 51 into the intrados 28.

[0177] A roller upset bending of this type is used when the structural requirements of the bent structural section make it necessary for the wall thickness of the extrados 29 and wall thickness of the side walls 50, 51 to remain the same also after the forming process. The enlargement of the wall thickness in the region of the intrados 28 is harmless in this case and increases the resistance moment of the curved structural section.

[0178] FIGS. 11 and 12 show an example embodiment of the roll-out bending with volume shift based on the example of a square hollow section 200×200×20 mm:

[0179] Calculation of the volume shift:

$$Ua/4=Da=\pi/4=(200\times 3.14):4=1,570 \text{ mm}$$

$$Ui/4=Di\times\pi/4=(1600\times 3.14):4=1,256 \text{ mm}$$

$$L=314 \text{ mm}$$

[0180] At 100% roll-out bending, the bending line is located at the intrados, i.e., the length layout does not change.

$$Fi=Ui\times Si=1256\times 20=25,120 \text{ mm}^2$$

[0181] $Sa=Fa/Ua=25120 \text{ mm}^2/1,570 \text{ mm}=16 \text{ mm}$ wall thickness on outside wall of the bend, i.e., $20-16=4 \text{ mm}$ must be rolled out, the sum of the volumes remains constant, i.e., $Fi=Fa$.

[0182] The side walls are rolled out conically in a symmetrical fashion from 4 mm at the outside toward 0 at the inside. In the reverse ratio $200:600=1/3$, at a penetration depth of 4 mm on the outside, the penetration depth on the inside is $4/3=1.33 \text{ mm}$. This lengthening on the inside is compensated for by the bending roller through compression.

[0183] In FIG. 11 the penetration depth is marked with 60 and the roll-out depth with 61. The amount of penetration depth that is present at the incoming side is marked with 60, whereas the amount (with opposite operational sign) at the discharge end is marked with 60'. The shift of the gravity line 58 to the further inwardly situated gravity line 58' takes place in the form of a small step 59 in the roll bending zone.

DRAWING LEGEND

[0184]	1 Structural section 1'
[0185]	2 Direction of arrow
[0186]	3 Central roller
[0187]	4 Forming roller
[0188]	5 Support roller
[0189]	6 Support roller
[0190]	7 Mandrel rod
[0191]	8 Mandrel shank
[0192]	9 Support element
[0193]	10 Support element
[0194]	11 Bending roller 11'
[0195]	12 Upper oscillating forming roller
[0196]	13 Lower oscillating forming roller
[0197]	14 Bending radius, outside
[0198]	15 Bending radius, inside
[0199]	16 Direction of arrow
[0200]	17 Direction of arrow
[0201]	18 Direction of arrow
[0202]	19 Direction of arrow
[0203]	20 Center axis (roller)
[0204]	21 Horizontal axis
[0205]	22 Swivel axis 22a, 22b
[0206]	23 Center axis (structural section)
[0207]	24 Direction of arrow
[0208]	25 Roller surface 25a, 25b
[0209]	26 Direction of arrow
[0210]	27 Upsetting thickness 27a
[0211]	28 Intrados 28', 28"
[0212]	29 Extrados 29'
[0213]	30 Bending line
[0214]	31 Material thinning
[0215]	32 Material increase 32'
[0216]	33 Direction of arrow
[0217]	34 Material thickening
[0218]	35 Roller surface 35'
[0219]	36 Degree of thinning
[0220]	37 Brake shoe, outside
[0221]	38 Brake shoe, inside
[0222]	39 Link chain
[0223]	40 Roller element
[0224]	41 Structural section thickening
[0225]	42
[0226]	43 Material thinning
[0227]	44 Material increase
[0228]	45 Angle α
[0229]	46 Positioning direction (left)
[0230]	47 Positioning direction (right)
[0231]	48 Material increase
[0232]	49 Direction of arrow

- [0233] 50 Side wall top
- [0234] 51 Side wall bottom
- [0235] 52 Inside of the bend
- [0236] 53 Outside of the bend
- [0237] 54 Neutral axis
- [0238] 55 Line
- [0239] 56 Material increase
- [0240] 57 Roller surface
- [0241] 58 Gravity line 58'
- [0242] 59 Step
- [0243] 60 Penetration depth 60'
- [0244] 61 Roll-out depth

What is claimed is

1. A bending apparatus for form bending of closed, half-open and open hollow sections having a central roller (3) coming to rest against the inside of the structural section being bent (1, 1'), a forming roller (4) coming to rest against the outside of the bend, and a bending roller (11) arranged at the discharge end of the structural section that acts upon the outside of the bend, namely counter to the support action of a support roller (5, 6) arranged on the outside of the bend at the incoming side, characterized in that there are disposed in a plane perpendicular to the bending plane with respect to the opposed central and forming rollers (3, 4) additional forming rollers (12, 13), which act upon the upper and lower side wall (50, 51) of the structural section.

2. A bending apparatus according to claim 1 characterized in that the forming rollers acting upon the side walls (50, 51) are designed as oscillating forming rollers (12, 13).

3. A bending apparatus according to claim 1 or 2, characterized in that the material flows generated in the front wall at the outside of the bend are deflected by means of the oscillating forming rollers (12, 13) acting upon the side walls (50, 51), over the associated side walls into the front wall at the inside of the bend.

4. A bending apparatus according to any of claims 1 through 3, characterized in that in the case of the roll-out bending, the upper and lower oscillating forming rollers (12, 13) are positioned conically inclined toward each other in their axial position against the plane-parallelism of the structural section to be bent.

5. A bending apparatus according to claim 4, characterized in that a greater roll-out depth is attained at the two upper and lower side walls (50, 51) on the outside of the bend than, by comparison, on the inside of the bend.

6. A bending apparatus according to claim 4 or 5, characterized in that the oscillating forming rollers (12, 13) have a relative penetration depth into the material at the upper and lower side wall (50, 51) on the outside of the bend, whereas the penetration depth tapers off toward 0 toward the inside of the bend.

7. A bending apparatus according to any of claims 4 through 6, characterized in that the bending line is moved to the inside of the bend and a grain flow is induced from the outside of the bend toward the inside of the bend.

8. A bending apparatus according to any of claims 4 through 7, characterized in that the roller (forming roller) on the outside of the bend is moved plane-parallel against the outside of the bend of the structural section, and that the roller (central roller) resting against the inside of the bend is moved plane-parallel against the inside of the bend.

9. A bending apparatus according to any of claims 4 through 8, characterized in that the forming and central rollers resting against the inside and outside of the bend are also designed oscillating and positioned inclined toward each other.

10. A bending apparatus according to any of claims 1 through 9, characterized in that in the case of the gravity bending of a symmetrical structural section, the bending line remains in the gravity line, approximately in the center of the structural section to be bent.

11. A bending apparatus according to any of claims 1 through 10, characterized in that the upper and lower oscillating forming rollers (12, 13) have an at least partly conical roller surface.

12. A bending apparatus according to claim 11, characterized in that in the region toward a central (middle) center line from the bending line outward, the contour has an incline and that from the bending line toward the inside of the bend, the contour of the upper and lower oscillating forming roller (12, 13) is plane-parallel to the structural section shape of the original unformed structural section.

13. A bending apparatus according to any of claims 1 through 12, characterized in that in the case of the roller upset bending, the bending line is moved toward the outside of the bend and the material thickenings of the side walls are deflected into the inside wall of the bend.

14. A bending apparatus according to any of claims 1 through 13, characterized in that the speed of the roller resting against the respective outside and inside of the structural section is less than the speed of the structural section through the bending gap.

15. A bending apparatus according to any of claims 1 through 14, characterized in that there are arranged at the inside and outside of the bend brake shoes that increase the resistance on the structural section to be bent, and a strong upsetting effect is created in the neutral axis.

16. A bending apparatus according to any of claims 1 through 15, characterized in that in addition to the oscillating rollers (12, 13), the central roller (3) and forming roller (4) are also designed to be swivelable

17. A bending apparatus according to any of claims 1 through 16, characterized in that the central roller and the opposed forming roller can be conically inclined as well

18. A method using an apparatus according to one or more of claims 1 through 17, characterized in that the material flows generated in the front wall at the outside of the bend are deflected over the associated side walls into the front wall at the inside of the bend.

19. A method according to claim 18, characterized in that in the case of the flow forming and bending, a grain flow is induced in the neutral axis of a structural section, extending from the outside of the bend of the structural section toward the inside of the bend, (roll-out bending).

20. A method according to claim 18, characterized in that in the case of the flow forming and bending, a grain flow is induced in the neutral axis of a structural section, extending from the inside of the bend of the structural section toward the outside of the bend (roller upset bending).

21. A method according to claim 18, characterized in that in the case of the flow forming and bending, the gravity line (=approximate bending line) remains intact unshifted, that as a result of the upsetting forces an increase of the material takes place starting from the bending center line of the structural section toward the inside of the bend, and that a material decrease in the same volume takes place via a roll-out process on the outside of the bend (), with the result that, due to the roll-out effects, upsetting and stretching forces are eliminated by the roll-out action, (gravity bending).

* * * * *