



US 20090025704A1

(19) **United States**  
(12) **Patent Application Publication**  
**Padula**

(10) **Pub. No.: US 2009/0025704 A1**  
(43) **Pub. Date: Jan. 29, 2009**

(54) **SYSTEMS AND METHODS FOR HEATING FOOD**

**Publication Classification**

(76) **Inventor: Cory Padula, Chilliwack (CA)**

(51) **Int. Cl. F24C 15/32 (2006.01)**

Correspondence Address:  
**SCHACHT LAW OFFICE, INC.**  
**SUITE 202, 2801 MERIDIAN STREET**  
**BELLINGHAM, WA 98225-2412 (US)**

(52) **U.S. Cl. .... 126/21 A**

(21) **Appl. No.: 12/220,114**

(57) **ABSTRACT**

(22) **Filed: Jul. 21, 2008**

**Related U.S. Application Data**

(60) **Provisional application No. 60/961,878, filed on Jul. 24, 2007.**

An oven for processing food comprising a housing assembly defining a vent opening. The vent opening allows at least a portion of fluid within the food heating chamber to flow out of an exhaust port.

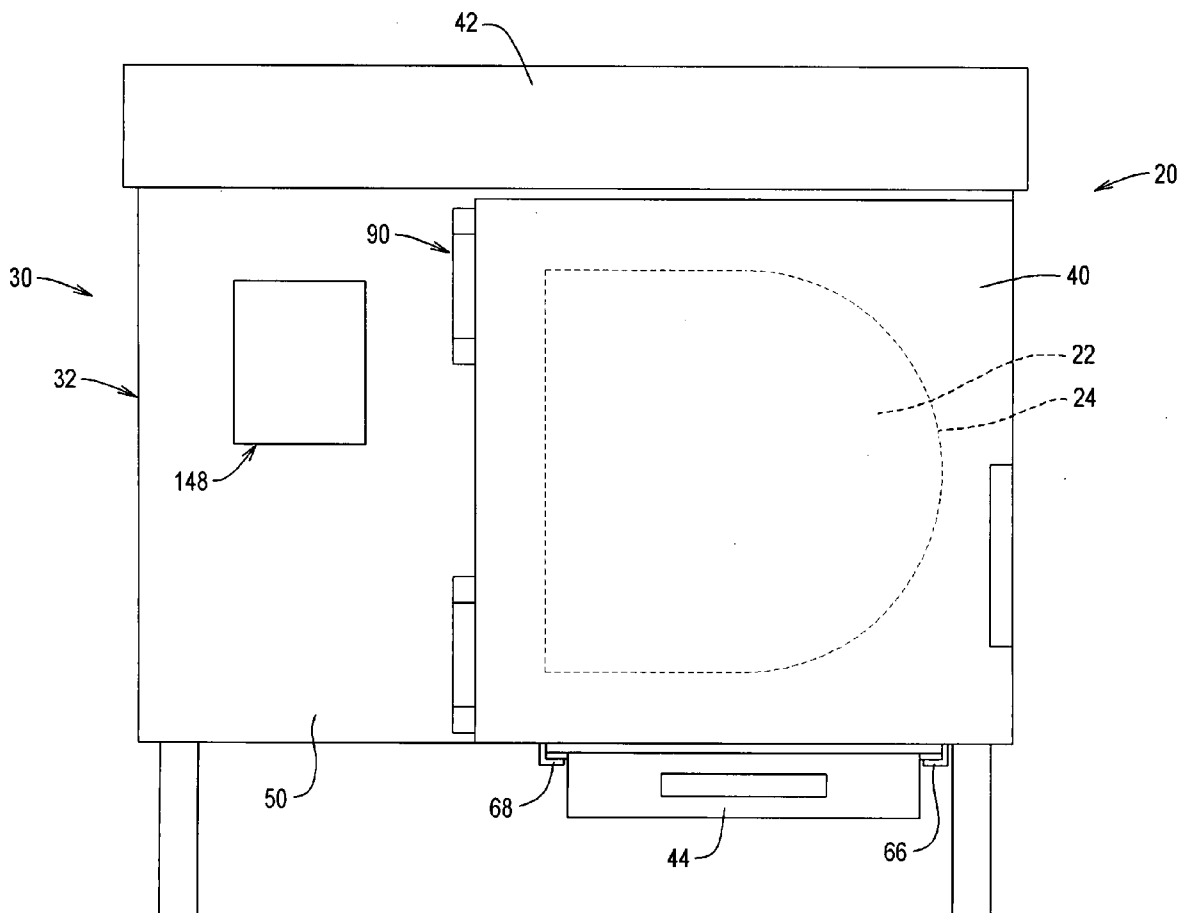

FIG. 1

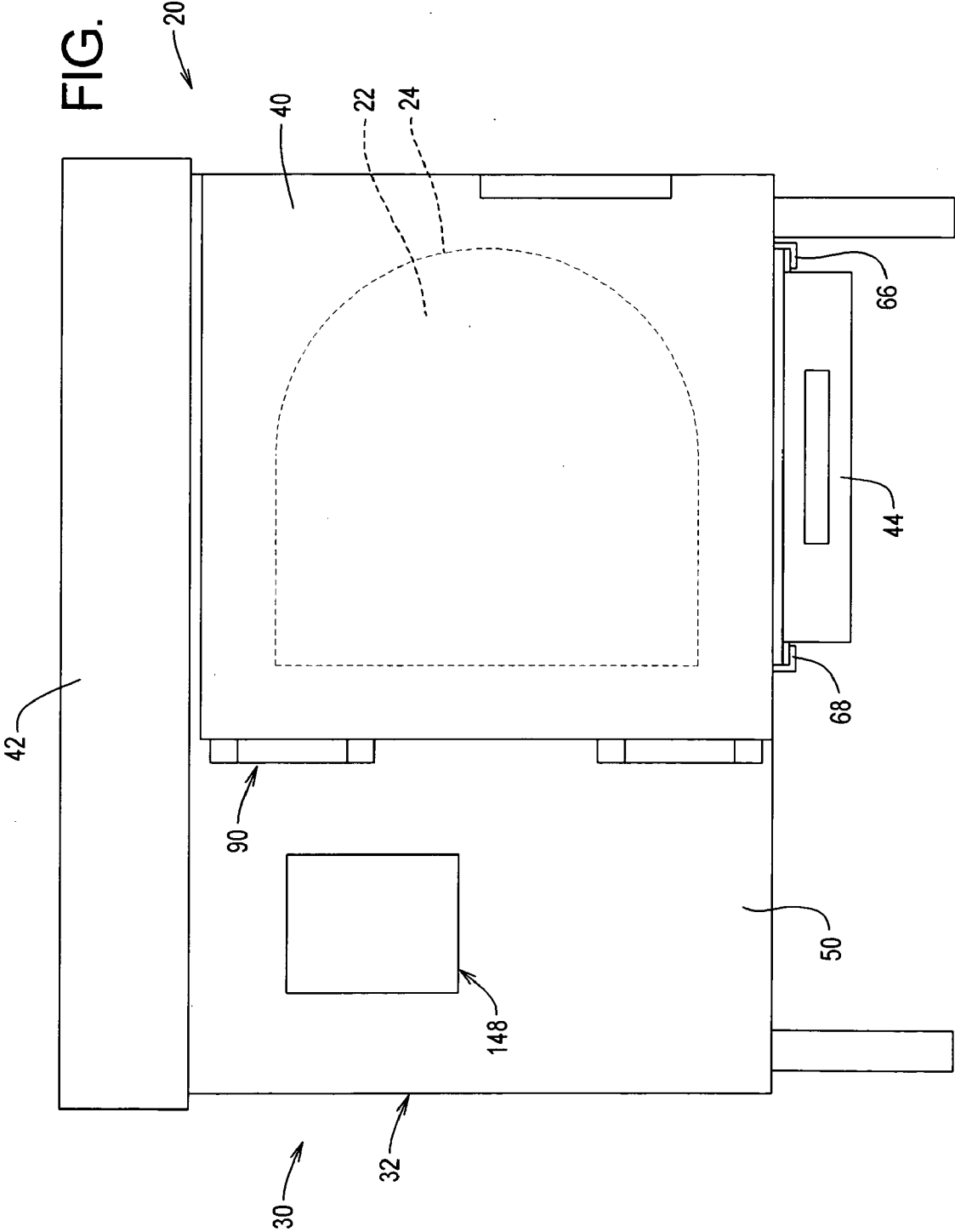

FIG. 2

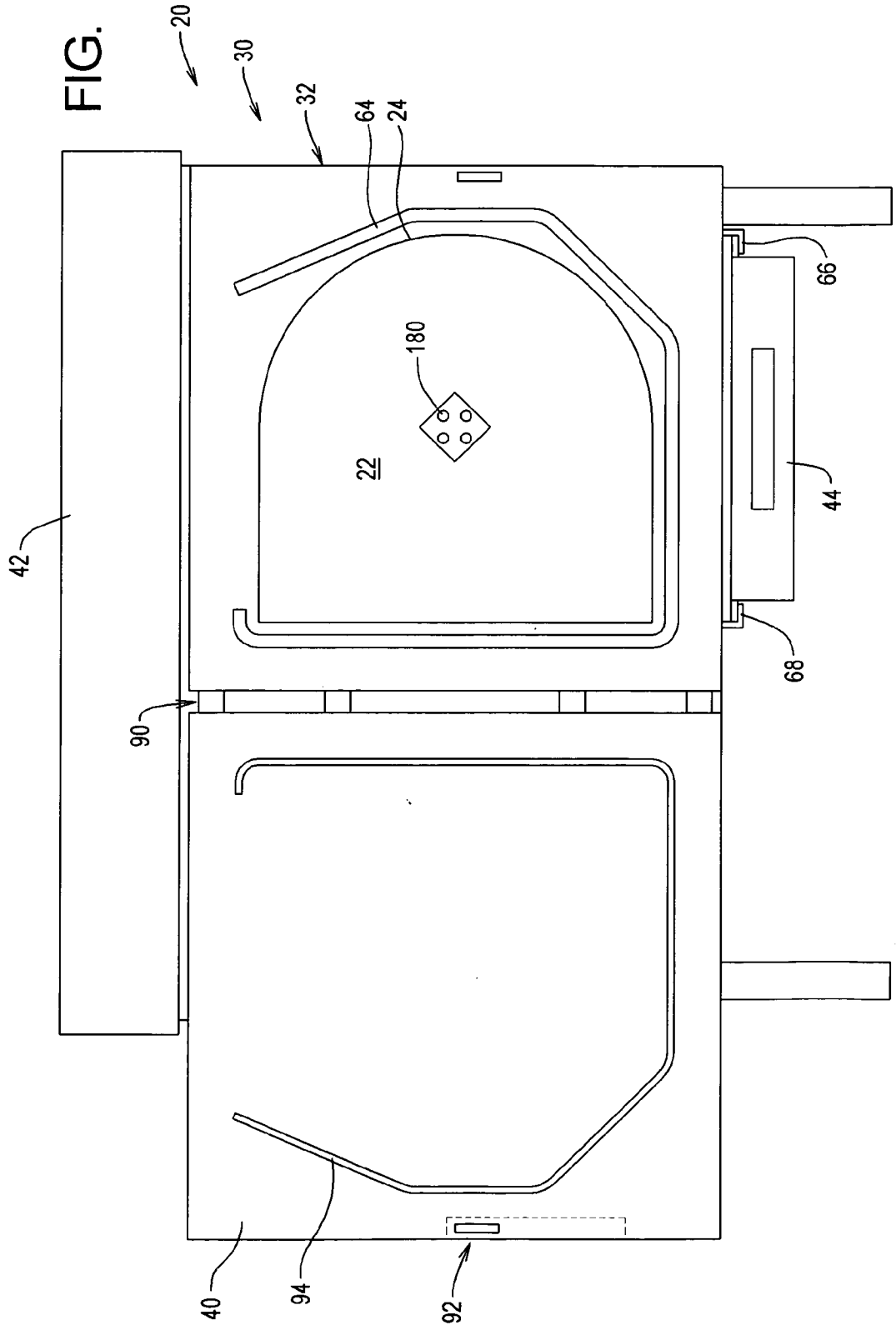

FIG. 3

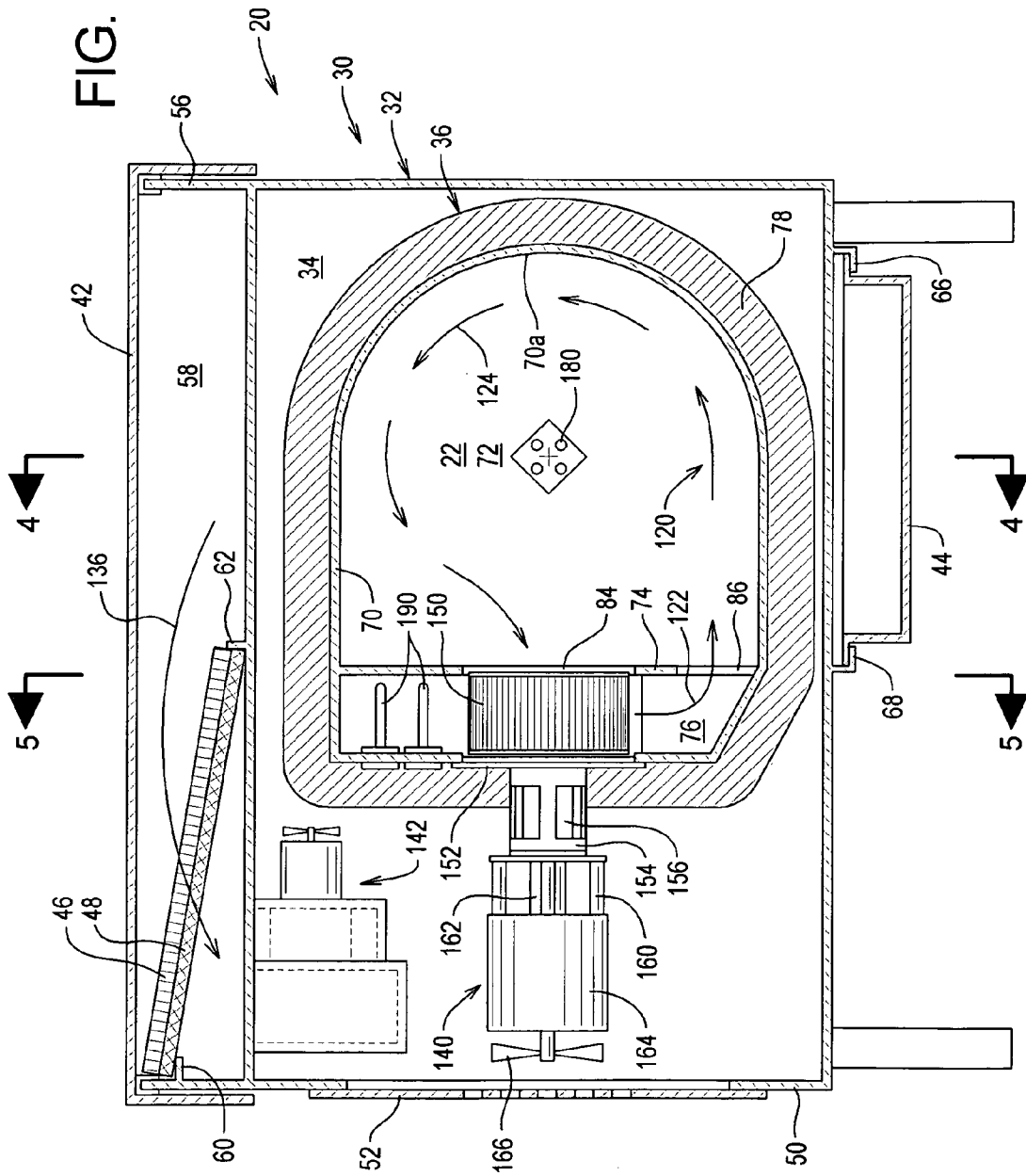

FIG. 4

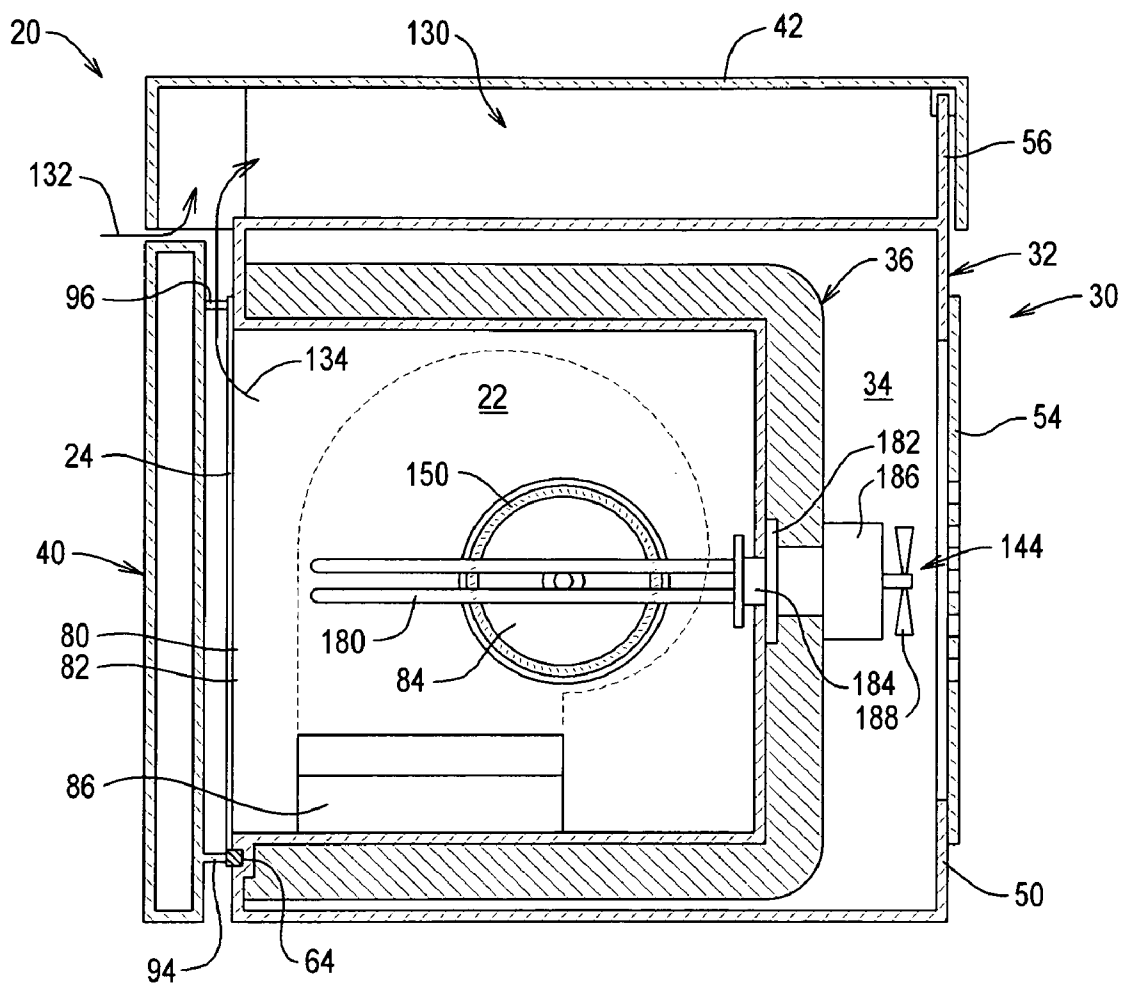
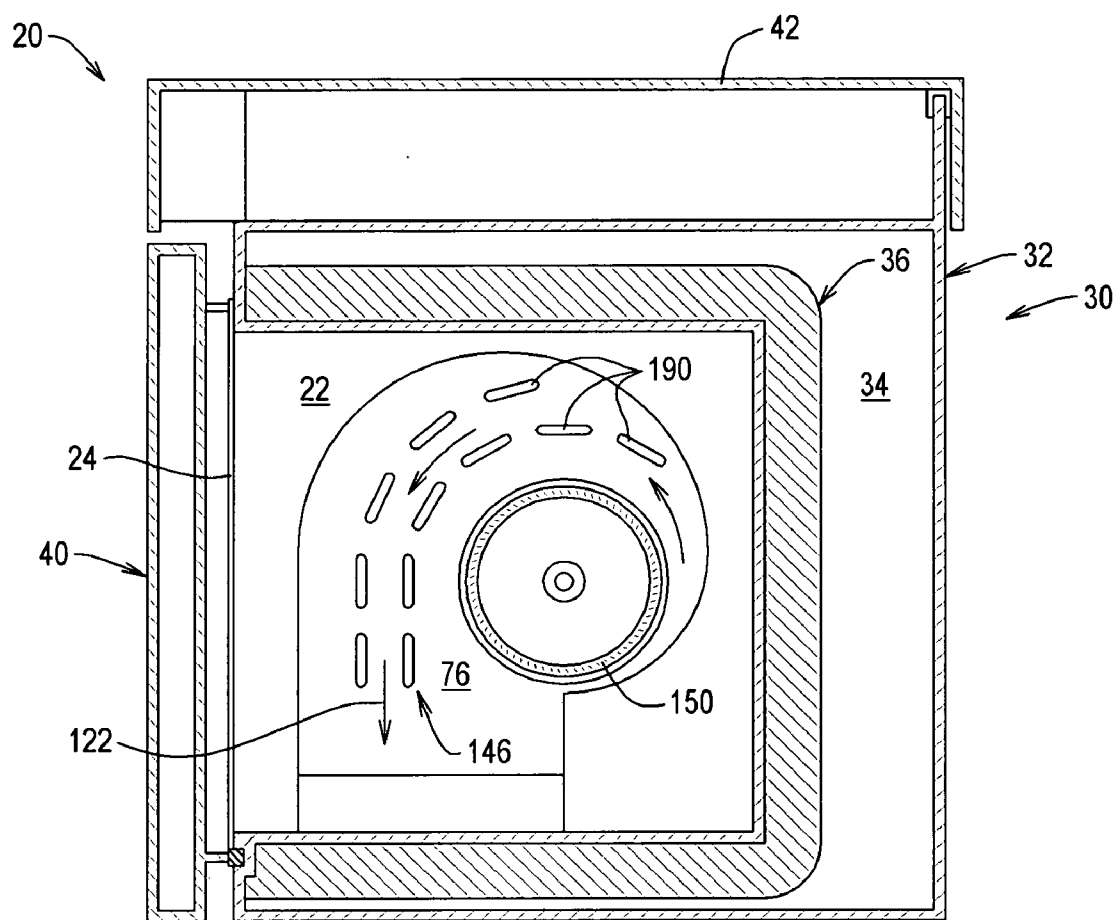
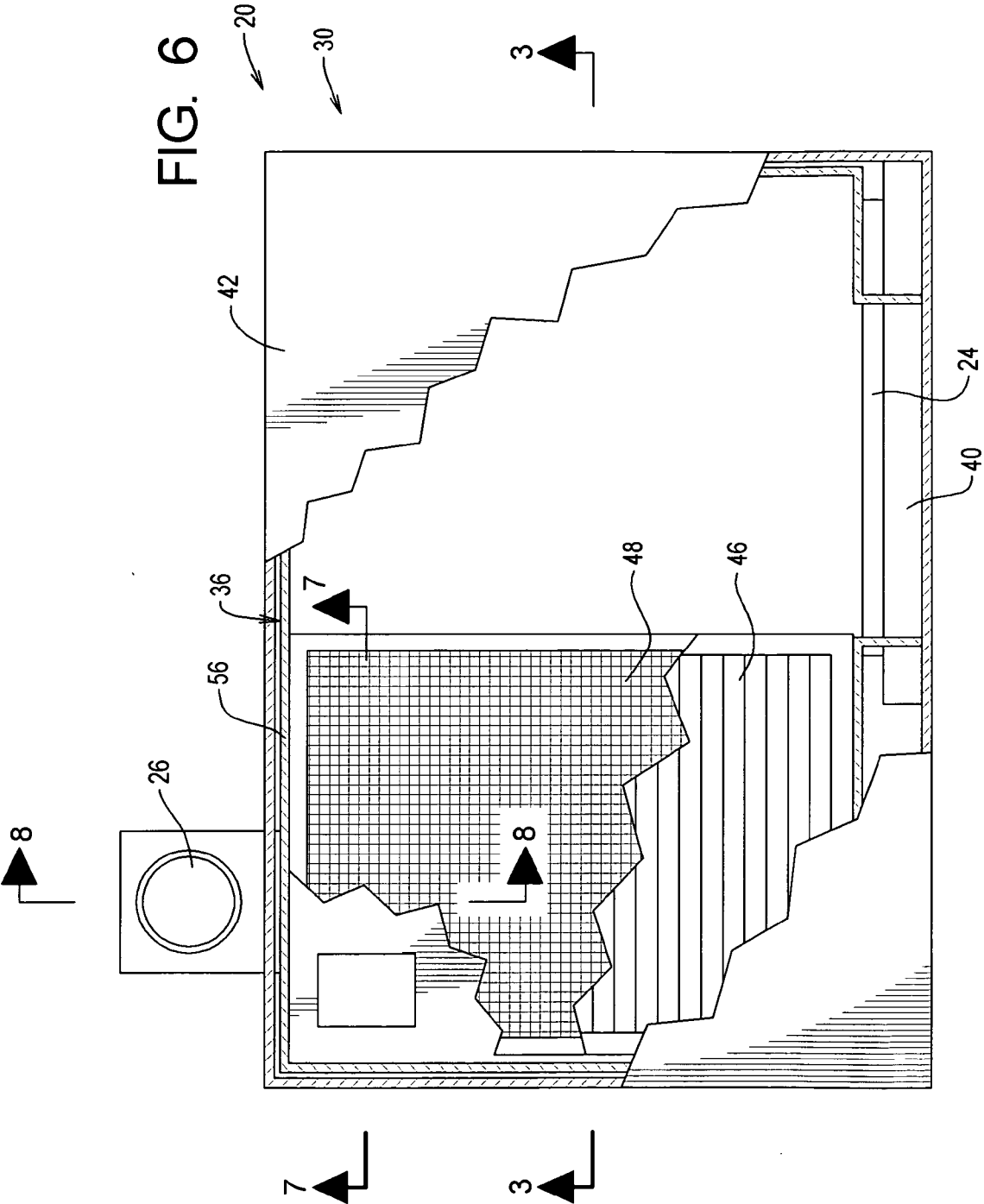
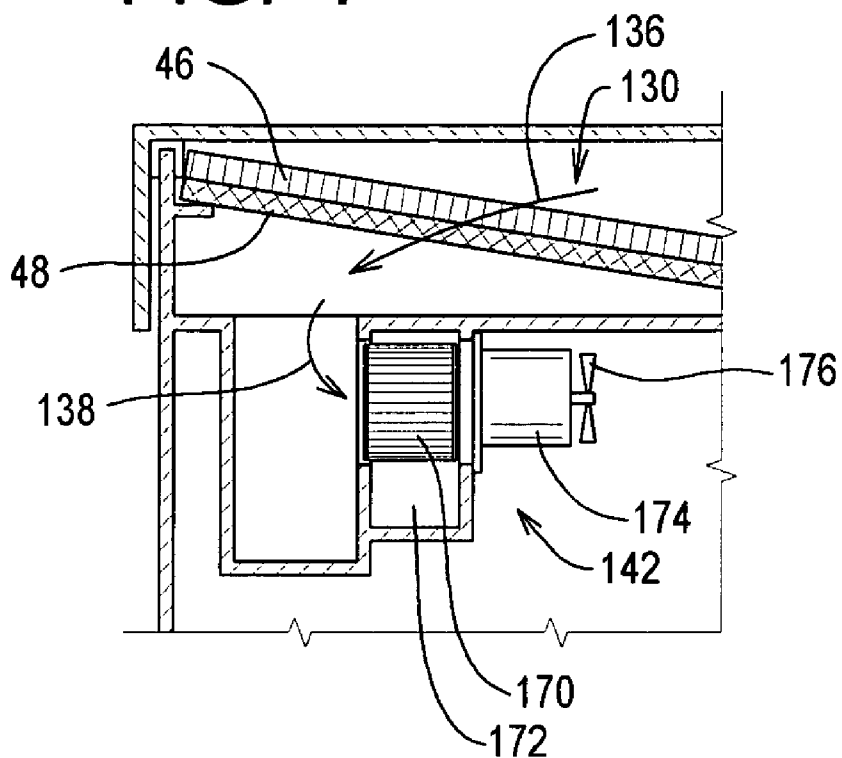

FIG. 5





# FIG. 7



# FIG. 8

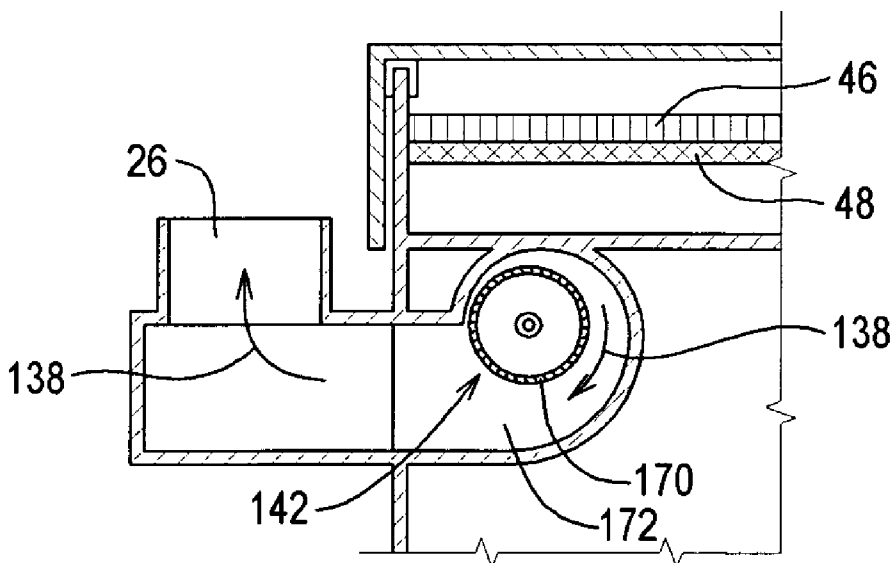



**SYSTEMS AND METHODS FOR HEATING FOOD**

**RELATED APPLICATIONS**

[0001] This application claims priority of U.S. Provisional Patent Application Ser. No. 60/961,878 filed Jul. 24, 2007, the contents of which are incorporated herein by reference.

**FIELD OF THE INVENTION**

[0002] The present invention relates to systems and methods for heating food and, more particularly, to systems and methods for heating food that employ circulating hot air.

**BACKGROUND OF THE INVENTION**

[0003] Ovens are enclosed compartments for heating, baking, and/or drying. The present invention is of particular significance when used to heat, bake, or dry food materials, and that application of the present invention will be described herein in detail.

[0004] Ovens are typically designed to generate heat using one or more energy sources such as solar, wood, coal, gas, or electricity. Additionally, ovens typically implement one or more of a variety of cooking methods, such as heating from above (e.g., broiling) or below (e.g., baking or roasting), convection (blowing air through or around the cooking chamber), steam, and microwave.

[0005] Additionally, ovens are further typically designed to operate in a given environment. For example, residential stoves are engineered for use in a personal residence, while commercial stoves are engineered for use in a commercial setting such as a restaurant. While not impossible, a commercial stove is not typically used in a personal residence and a residential stove is not typically used in a commercial setting. A commercial stove typically requires electrical, gas, plumbing, and/or ventilation hook-ups not normally available in a typical residence. And a residential stove may not be sufficiently durable for or meet safety and sanitary requirements of a commercial setting.

[0006] The present invention generally relates to a commercial oven that may be designed to operate using any convenient energy source and which incorporates aspects of convection and steam ovens.

**SUMMARY OF THE INVENTION**

[0007] The present invention may be embodied as an oven for processing food comprising a housing assembly, a blower fan assembly, and an exhaust fan assembly. The housing assembly comprises an outer housing assembly defining, an inner housing assembly, and a door member.

[0008] The outer housing assembly defines a main chamber, an exhaust chamber, an exhaust opening, and an outer access opening. The inner housing assembly is arranged within the main chamber and comprises an inner housing member defining an inner chamber and an inner access opening and a baffle member arranged to divide the inner chamber into a food heating chamber and an air heating chamber. The door member is rotatably attached to the outer housing assembly.

[0009] The blower fan assembly is at least partly disposed within the air heating chamber. The exhaust fan assembly is supported relative to the outer housing assembly. The outer access opening and the inner access opening at least partly align to define an access port. A vent opening is defined by the

housing assembly, where the vent opening allows at least a portion of fluid within the food heating chamber to flow into the exhaust chamber. The exhaust chamber is in fluid communication with the vent opening.

[0010] Operation of the blower fan assembly causes air within the air heating chamber to flow into the food heating chamber. Operation of the exhaust fan assembly draws at least a portion of any fluid exiting the food heating chamber through the vent port, through the exhaust chamber, and out of the exhaust port.

[0011] The present invention may also be embodied as an oven for processing food comprising a housing assembly, a blower fan assembly. The blower fan assembly comprises a blower fan disposed within the air heating chamber, a blower motor for rotating the blower fan, and a motor standoff assembly. The motor standoff assembly is configured to support the blower motor relative to the inner housing member such that transmission of heat from the inner housing member to the blower motor is inhibited.

[0012] The present invention may also be embodied as an oven for processing food comprising a housing assembly and a blower fan assembly. The housing assembly comprises an outer housing assembly, an inner housing assembly, and a door member. The inner housing assembly comprises an inner housing member defining an inner chamber and an inner access opening, where a ratio of the bulk volume of the inner housing member to the volume of the food heating chamber is within a range of 1:5.5 to 1:8.

[0013] An oven for processing food comprising a housing assembly and a blower fan assembly. The housing assembly comprises an outer housing assembly, an inner housing assembly, and a door member. The housing assembly defines a vent opening. The inner housing assembly defines a food heating chamber, a return inlet opening, and an outlet opening. A ratio of the interior surface area of a food heating chamber to areas of the return inlet opening, the outlet opening, and the vent opening is approximately within a range of 40:1:0.6:0.16 to 50:1:0.85:0.28.

**BRIEF DESCRIPTION OF THE DRAWINGS**

[0014] FIG. 1 is a front elevation view of an example food heating system constructed in accordance with, and embodying, the principles of the present invention;

[0015] FIG. 2 is a front elevation view similar to FIG. 1 illustrating a door in an open configuration;

[0016] FIG. 3 is a section view of the food heating system of FIG. 1 taken along lines 3-3 in FIG. 6;

[0017] FIG. 4 is a section view of the food heating system of FIG. 1 taken along lines 4-4 in FIG. 3;

[0018] FIG. 5 is a section view of the food heating system of FIG. 1 taken along lines 5-5 in FIG. 3;

[0019] FIG. 6 is a top plan view of the food heating system of FIG. 1 with portions cutaway to illustrate an exhaust system thereof;

[0020] FIG. 7 is a section view of the food heating system of FIG. 1 taken along lines 7-7 in FIG. 6 illustrating a second portion of an exhaust path; and

[0021] FIG. 8 is a section view of the food heating system of FIG. 1 taken along lines 8-8 in FIG. 6 illustrating a third portion of an exhaust path.

**DETAILED DESCRIPTION OF THE INVENTION**

[0022] Referring initially to FIG. 1 of the drawing, depicted therein is an example food heating system 20 constructed in

accordance with, and embodying, the principles of the present invention. The example food heating system 20 defines a food heating chamber 22 (FIGS. 2-5), an access port 24 (FIGS. 1, 2, 4, and 5), and an exhaust port 26 (FIGS. 6 and 8).

[0023] Food to be heated is placed into the food heating chamber 22 through the access port 24. The food heating system 20 heats food within the heating chamber for one or more of the following purposes: warming, cooking, and dehydrating.

[0024] The example food heating system 20 comprises a housing assembly 30 comprising an outer housing assembly 32 defining a main chamber 34 and an inner housing assembly 36 defining the food heating chamber 22. The inner housing assembly 36 is rigidly connected to the outer housing assembly 32 and arranged within the main chamber 34. The housing assembly 30 further comprises a door member 40, a cover member 42, a drip pan 44, a condenser member 46, and a filter member 48.

[0025] The outer housing assembly 32 comprises a main housing member 50, a side vent plate 52 (FIG. 3), and a rear vent plate 54 (FIG. 4). The side and rear vent plates 52 and 54 are detachably attached to the main housing member 50.

[0026] An upper flange 56 extends upwardly from the main housing member 50. The upper flange engages the cover member 42 to define an exhaust chamber 58 above the main chamber 34. A first support flange 60 is formed on the main housing member 50, while a second support flange 62 is formed on the upper flange 56. A seal recess 64 is formed on the main housing member 50 such that the seal recess 64 partly surrounds the access port 24 as will be described in further detail below.

[0027] The first and second support flanges 60 and 62 are disposed within the exhaust chamber 58. The support flanges 60 and 62 support the filter member 48 and the condenser member 46 within the exhaust chamber 58 as shown in FIG. 3. The present invention may be embodied with one or both of the filter member 48 and the condenser member 46 arranged within the exhaust chamber 58.

[0028] First and second pan support flanges 66 and 68 extend downwardly from the main housing member 50 to support the drip pan 44. As is conventional, a drain path (not shown) is established between the heating chamber 22 and the drip pan 44 to allow the drip pan 44 to collect liquid byproducts of the cooking process. In the context of the present invention, the term "fluid" will be used to refer to one or more of gasses, liquids, vapors, and airborne particles. Typically, the fluids flowing along the drain path will be liquids.

[0029] The inner housing assembly 36 will now be described in further detail with reference to FIGS. 3-5. The inner housing assembly 36 comprises an inner housing member 70 that is rigidly connected to the main housing member 50. The inner housing member 70 defines an inner chamber 72. A baffle member 74 is secured to the inner housing member 70 within the inner chamber 72 to divide the inner chamber 72 into the food heating chamber 22 and an air heating chamber 76.

[0030] The inner housing member 70 is surrounded or coated by a layer of insulation 78 to inhibit transfer of heat between the inner chamber 72 and the main chamber 34 defined by the outer housing assembly 32.

[0031] The main housing member 50 defines an outer access opening 80, while the inner housing member 70 defines an inner access opening 82. The inner housing mem-

ber 70 is rigidly connected to the main housing member 50 such that the outer and inner access openings 80 and 82 are aligned with each other and define the access port 24. The seal recess 64 extends substantially around the bottom and sides of the access port 24 defined by the access openings 80 and 82.

[0032] As perhaps best shown in FIG. 3, the baffle member 74 defines a fan inlet opening 84, and the baffle member 74 and inner housing member 70 together define a fan outlet opening 86. As will be described in further detail below, the fan inlet and outlet openings 84 and 86 allow fluid to flow between the heating chamber 22 and the air heating chamber 76. A distal wall 70a of the inner housing member 70 away from the baffle member 74 is curved for the purpose of redirecting air exiting the fan outlet opening 86 back around the heating chamber 22 and into the fan inlet opening 84.

[0033] A hinge assembly 90 rotatably attaches the door member 40 to the main housing member 50 such that the door member 40 may rotate between closed (FIG. 1) and open (FIG. 2) positions relative to the housing assembly 30. A latch assembly 92 secures the door member 40 in the closed position.

[0034] In addition, a seal projection 94 extends from the door member 40. The size, shape, and dimensions of the seal projection 94 are such that the seal recess 64 receives the seal projection when the door member 40 is in its closed position. When the seal projection 94 extends at least partly into the seal recess formed in the main housing member 50, flow of fluid along bottom and side edges of the access port 24 is substantially prevented, but fluid may flow out of the heating chamber 22 through a door vent opening 96 formed along a top edge of the access port 24.

[0035] Accordingly, when the door member 40 is in the open position, the access port 24 allows access to the heating chamber 22. When the door member 40 is in the closed position, access to the heating chamber 22 is substantially prevented, but fluid may flow out of the heating chamber 22 through the door vent opening 24.

[0036] When used as part of the food heating system 20, the housing assembly 30 as described above defines to primary fluid flow paths. FIGS. 3 and 5 illustrate a circulation path 120 comprising a first portion 122 (FIGS. 3 and 5) and a second portion 124 (FIG. 3).

[0037] FIGS. 3, 4, 7, and 8 illustrate an exhaust path 130 comprising first and second inlet portions 132 and 134 (FIG. 4), a process portion 136 (FIGS. 3 and 7), and an outlet portion 138 (FIG. 8). In the context of the circulation path 120 and the exhaust path 130, fluids flowing along these paths 120 and 130 will typically be one or more of gasses, vapors, and/or airborne particles. The circulation path 120 and the exhaust path 130 will be described in further detail below.

[0038] In addition to the housing assembly 30, the food heating system 20 comprises one or more active components. The example food heating system 20 comprises a blower fan assembly 140, an exhaust fan assembly 142, a rotisserie assembly 144 (FIG. 4), a heating system 146 (FIG. 5), and a control system 148 (FIG. 1).

[0039] As shown in FIG. 3, the blower fan assembly 140 comprises a circulating fan 150, a cover plate 152, a bearing housing mount 154, a bearing housing assembly 156, a motor standoff assembly 160, a drive coupling assembly 162, a blower motor 164, and a blower motor fan 166.

[0040] The cover plate 152 is rigidly connected to the inner housing member 70 and supports the bearing housing mount 154 outside of the inner chamber 72. The bearing housing

mount **154** supports the bearing assembly **156** outside of the inner chamber **72**, and the bearing assembly **156** in turn supports the circulating fan **150** within the fan chamber portion **76** of the inner chamber **72**.

[0041] The motor standoff assembly **160** is rigidly connected to the bearing housing mount **154** and supports the blower motor **164**. The drive coupling assembly **162** operatively connects the blower motor **164** to the bearing assembly **156** such that operation of the blower motor **164** causes rotation of the fan **150** through the driving coupling assembly **162** and the blower bearing assembly **156**.

[0042] The use of the motor standoff assembly **160** to support the blower motor **164** inhibits the transmission of heat from the inner housing member **70** to the blower motor **164**. Operation of the blower motor **164** rotates the blower motor fan **166** to draw cool air through the side vent plate **52** and over the blower motor **164**. The mechanical structure used to support the blower motor **164** is thus designed to reduce an operating temperature of the blower motor **164** and blower bearing assembly **156** and thus reduce thermal wear thereon.

[0043] As perhaps best shown in FIG. 7 of the drawing, the exhaust fan assembly **142** comprises an exhaust chamber fan **170** that is located within an exhaust fan chamber **172**. The exhaust fan assembly **142** further comprises an exhaust motor **174** and an exhaust motor fan **176**. The exhaust motor **174** is coupled to the exhaust chamber fan **170** such that operation of the motor **174** rotates the exhaust chamber fan **170**. Operation of the exhaust motor **174** further rotates the exhaust motor fan **176** such that relatively cool air is directed over and cools the exhaust motor **174**.

[0044] The rotisserie assembly **144** is provided as a standard feature, but is not part of the present invention per se and need not be used depending upon the type of food being heated. As perhaps best shown in FIG. 4, the example rotisserie assembly **144** comprises a rotisserie member **180**, a rotisserie cover plate **182**, a rotisserie bearing assembly **184**, a rotisserie motor **186**, and a rotisserie motor fan **188**.

[0045] The rotisserie cover plate **182** secures the rotisserie bearing assembly **184** to the inner housing member **70**. The rotisserie member **180** is detachably attached to the rotisserie bearing assembly **184** and is arranged within the food heating chamber **22** when used. The rotisserie motor **186** is operatively connected to the rotisserie bearing assembly **184** such that operation of the motor **186** causes axial rotation of the rotisserie member **180**. The rotisserie motor fan **188** directs relatively cool air across the rotisserie motor **186** when the motor **186** operates.

[0046] The example rotisserie member **180** is a spit rod that extends into and supports food to be heated, but the rotisserie member **180** may take the form of a basket or other food support mechanism. Alternatively, if the rotisserie assembly **144** is not used, the rotisserie member **180** is removed and the rotisserie motor **186** is not operated. In this case, the food to be heated may be supported by other means such as a basket, tray, pan, or the like supported directly from the inner housing member **70** within the food heating chamber **22**.

[0047] Referring now to FIGS. 3 and 5, it can be seen that the example heating system **146** comprises a plurality of heating elements **190** arranged within the fan chamber portion **76** of the inner chamber **72**. The example heating elements **190** are electric resistance heaters the temperature of which is a function of electric current flowing therethrough. The example heating elements **190** are or may be conventional and need not be described herein in further detail.

While the example heating system **146** employs electrical heating elements **190**, alternative heat sources such as gas burners may be used depending upon the preferences of the owner of the food heating system **20**.

[0048] In any case, the example control system **148** is capable of controlling the amount of heat generated by the heating system **146**. The control system further comprises one or more timers that control how long the heating system **146** is operated. The example control system **148** is or may be conventional and will not be described herein beyond the extent necessary for a complete understanding of the present invention.

[0049] The example food heating system **20** operates basically as follows. Initially, the heating system **146** will pre-heat the food heating chamber **22** to a predetermined start temperature under control of the control system **148**. In particular, with the door member **40** in its closed position, current is passed through the heating elements **190** such that the air within the air heating chamber **76** is heated.

[0050] At the same time, the blower fan assembly **140** is operated to cause rotation of the blower fan **150**. The blower fan **150** draws air along the circulation path **120** from the food heating chamber **22** into the fan chamber **76** through the fan inlet opening **84** and forces air out of the air heating chamber **76** into the food heating chamber **22** through the fan outlet opening **86**. Hot air thus circulates between the air heating chamber **76** (or first portion **122** of the circulation path **120**) and the food heating chamber **22** (or second portion **124** of the circulation path **120**).

[0051] When the predetermined start temperature is reached, food to be heated is placed into the food heating chamber **22**. Typically, if the food heating chamber **22** has been pre-heated, the door member **40** must be moved into the opening position. Food to be cooked is then supported within the food heating chamber **22**; when the rotisserie member **180** is used, the food to be heated and/or cooked is most likely meat, but can also be diced vegetables and/or any piece-form food product. With the food to be cooked within the food heating chamber **22**, the door member **40** is placed into the closed position and held in the closed position by the latch assembly **92**.

[0052] The control system **148** then operates one or both of the heating system **146** and the rotisserie assembly **144** to maintain a particular cooking profile within the food heating chamber **22**. In particular, the control system **148** creates a cooking profile by controlling one or more factors such as current through the heating elements **190**, speed of the blower fan **150**, or the like based on one or more parameters such as time, temperature, humidity, and the like.

[0053] A particular food item will typically have a predetermined cooking profile based on the parameters of the food item. For example, a particular cut of meat supported by a rotisserie member may have a different cooking temperature and cooking time than a pizza supported on a baking pan. As another example, a five pound cut of meat may have a different cooking temperature and cooking time than a one pound cut of the same type of meat. The control system allows the cooking profile to be determined for each food item or may be configured to allow a desired cooking profile to be selected from a plurality of predetermined cooking profiles.

[0054] As the food is heated, the exhaust fan assembly **142** is continuously operated to draw a stream of exhaust fluid along the exhaust path **130**. As described above, the exhaust stream flowing along the exhaust path **130** enters through

either one or both of a first inlet portion 132 and a second inlet portion 134. The first inlet portion 132 allows ambient air to flow into the exhaust path 130; the second inlet portion 134 allows fluids within the food heating chamber 22 to enter the exhaust path 130 through the door vent opening 96.

[0055] The exhaust stream flowing along the exhaust path 130 is thus a mixture of ambient air and fluids within the food heating chamber 22. The food heating chamber 22 does not have a fluid inlet, so fluids exiting the food heating chamber 22 are primarily due to expansion of gasses and vapors due to the heating process. The second inlet portion 134 of the exhaust path 130 thus prevents buildup of pressure within the food heating chamber 22 but otherwise does not allow significant exchange of air and other fluids within food heating chamber 22.

[0056] The exhaust stream moving along the process portion 136 of the exhaust path 130 next passes into the exhaust chamber 58. As perhaps best shown in FIGS. 3 and 6, the support flanges 60 and 62 support the condenser member 46 and the filter member 48 such that exhaust stream flowing through the process portion 136 of the exhaust path 130 is drawn first through the condenser member 46 and then the filter member 48.

[0057] The condenser member 46 is configured to convert steam flowing along the process portion 136 from its gaseous state to its liquid state. The liquid removed from the exhaust stream is then drained into exhaust chamber 58 and disposed of. The filter member 48 is configured to remove particulates and droplets carried by the exhaust stream. After passing through the process portion 136 of the exhaust path 130, the exhaust stream is relatively free of steam, particulates, and droplets that could contaminate components downstream of the process portion 136.

[0058] As shown in FIGS. 7 and 8, after the exhaust stream passes through the process portion 136 of the exhaust path 130, the exhaust stream enters the exhaust fan chamber 172 containing the exhaust chamber fan 170. As described above, the rotation of the exhaust chamber fan 170 creates a relatively low pressure area within the exhaust fan chamber 172 that draws air into the chamber 172 and then forces air out of the chamber 172 and ultimately out of the exhaust port 26. The exhaust port 26 will typically be connected to a conduit that is vented to the atmosphere.

[0059] In the example food heating system 20, the inner housing member 70 is made of cast iron and is insulated. The inner housing member 70 thus acts as a heat sink that absorbs and then radiates heat for more efficient use of the energy consumed by the heating system 146. The Applicant has discovered that operation of the food system is optimized when a ratio of the bulk volume (weight/density) of the inner housing member 70 to the volume of the food heating chamber 22 is approximately 1:6.65; this ratio is preferably within a first range of 1:6 to 1:7 but in any event should be within a second range of 1:5.5 to 1:8.

[0060] In addition, the construction of the blower fan assembly 140, which at least partly insulates the blower motor 164 from the inner housing member 70, allows the temperature of the food heating chamber 22 to be raised to approximately 850° F., which is well in excess of normal cooking temperatures in the range of approximately 350° F. to 500° F. The partial isolation of the blower motor 164 from the inner housing member 70 thus allows the use of elevated

temperatures and blower motor 164 on a daily basis to clean the interior of the food heating chamber 22 without harming the blower motor 164.

[0061] The example fan inlet opening 84, fan outlet opening 86, and door vent opening 96 are sized and dimensioned relative to the volume of the food heating chamber 22 to optimize the circulation flow and exhaust flow for most cooking processes. In the example food heating system 20, a ratio of the interior surface area prescribed by the confines of the food heating chamber 22 to areas of the return inlet opening 84, the outlet opening 86, and the vent opening 96 is approximately 44:1:0.7:0.2; this ratio is preferably within a first range of 42:1:0.65:0.18 to 46:1:0.75:0.22 but in any event should be within a second range of 40:1:0.6:0.16 to 50:1:0.85:0.28.

[0062] One example food heating system constructed in accordance with the principles of the present invention has the following dimensions:

Volume - food heating chamber 22	2122 cu. in.
Volume - air heating chamber 76	440 cu. in.
Cross Sectional Area -- fan inlet opening 84	22.0 sq. in.
Cross Sectional Area - fan outlet opening 86	15.2 sq. in.
Cross Sectional Area - door vent opening 96	4.40 sq. in.
Interior Surface Area - food heating chamber 22	964 sq. in.
Interior Surface Area - air heating chamber 76	396 sq. in.
Bulk Volume -- inner housing member 70	320 cu. in.

[0063] In the context of the example described in the foregoing table, the ratio between the volumes of food cooking chamber 22 to the air heating chamber 76 is 4.83:1, the ratio between the interior surface area of the air heating chamber 76 to the fan inlet opening 84 and the fan outlet opening 86 is 18:1:0.7, the ratio between the interior surface area of the food cooking chamber 22 to the area of the door vent opening 96 is 219:1, and the ratio of the bulk volume (weight/density) of the inner housing member 70 to the volume of the food heating chamber 22 is 1:6.65.

[0064] Although a specific example of a food heating system 20 is depicted and described herein, the present invention may be embodied in forms other than those described herein. The scope of the present invention should thus be determined by the claims appended hereto and not the foregoing detailed description.

What is claimed is:

1. An oven for processing food, comprising:
  - a housing assembly comprising
    - an outer housing assembly defining a main chamber, an exhaust chamber, an exhaust opening, and an outer access opening, and
    - an inner housing assembly arranged within the main chamber, where the inner housing assembly comprises
      - an inner housing member defining an inner chamber and an inner access opening, and
      - a baffle member arranged to divide the inner chamber into a food heating chamber and an air heating chamber,
      - a door member rotatably attached to the outer housing assembly;
  - a blower fan assembly at least partly disposed within the air heating chamber;
  - an exhaust fan assembly supported relative to the outer housing assembly; whereby

the outer access opening and the inner access opening at least partly align to define an access port;

the door member rotates between

- an open position in which the inner chamber is accessible through the access port, and
- a closed position in which the inner chamber is not accessible through the access port;

a vent opening is defined by the housing assembly, where the vent opening allows at least a portion of fluid within the food heating chamber to flow into the exhaust chamber;

the exhaust chamber is in fluid communication with the vent opening;

operation of the blower fan assembly causes air within the air heating chamber to flow into the food heating chamber; and

operation of the exhaust fan assembly draws at least a portion of any fluid exiting the food heating chamber through the vent port, through the exhaust chamber, and out of the exhaust port.

**2.** An oven as recited in claim 1, in which operation of the exhaust fan assembly further draws ambient air into the exhaust chamber.

**3.** An oven as recited in claim 1, further comprising a heating system arranged to heat air within the air heating chamber.

**4.** An oven as recited in claim 3, in which the heating system comprises at least one heating element arranged within the air heating chamber.

**5.** An oven as recited in claim 1, in which:

- a gap is defined between the door member and the outer housing assembly when the door member is in the closed position; and

when the door member is in the closed position, the door member engages the outer housing assembly such that fluid flow is substantially prevented through a first portion of the gap, and

- the vent opening is defined by a second portion of the gap.

**6.** An oven as recited in claim 5, further comprising a seal system adapted to inhibit flow of air through the first portion of the gap.

**7.** An oven as recited in claim 6, in which the seal system comprises:

- a seal projection extending from the door member; and
- a seal recess formed in the outer housing assembly; whereby

the seal projection is adapted to engage the seal recess to inhibit fluid flow through the first portion of the gap.

**8.** An oven as recited in claim 1, in which the blower fan assembly comprises:

- a blower motor, and
- a motor standoff assembly; whereby

the motor standoff assembly is configured to inhibit transmission of heat from the inner housing member to the blower motor.

**9.** An oven as recited in claim 1, in which:

- the outer housing assembly comprises a main housing member comprising an upper flange; and

the housing assembly further comprises a cover member adapted to be supported by the upper flange, where the exhaust chamber is defined by the main housing member and the cover member.

**10.** An oven as recited in claim 1, further comprising a filter member arranged within the exhaust chamber to filter fluid flowing through the exhaust chamber.

**11.** An oven as recited in claim 1, further comprising a condenser member arranged within the exhaust chamber.

**12.** An oven for processing food, comprising:

- a housing assembly comprising
  - an outer housing assembly defining a main chamber and an outer access opening,
  - an inner housing assembly arranged within the main chamber, where the inner housing assembly comprises
    - an inner housing member defining an inner chamber and an inner access opening, and
    - a baffle member arranged to divide the inner chamber into a food heating chamber and an air heating chamber, and
  - a door member rotatably attached to the outer housing assembly;
- a blower fan assembly comprising
  - a blower fan disposed within the air heating chamber,
  - a blower motor for rotating the blower fan, and
  - a motor standoff assembly configured to support the blower motor relative to the inner housing member such that transmission of heat from the inner housing member to the blower motor is inhibited;

the outer access opening and the inner access opening at least partly align to define an access port;

the door member rotates between

- an open position in which the inner chamber is accessible through the access port, and
- a closed position in which the inner chamber is not accessible through the access port; and

operation of the blower fan assembly causes air within the air heating chamber to circulate through the food heating chamber.

**13.** An oven as recited in claim 12, further comprising a heating system arranged to heat air within the air heating chamber.

**14.** An oven as recited in claim 13, in which the heating system comprises at least one heating element arranged within the air heating chamber.

**15.** An oven as recited in claim 12, in which:

- the outer housing assembly defines an exhaust chamber and an exhaust opening;
- the housing assembly defines a vent opening that allows at least a portion of fluid within the food heating chamber to flow into the exhaust chamber; and

the oven further comprises an exhaust fan assembly that draws at least a portion of any fluid exiting the food heating chamber through the vent port, through the exhaust chamber, and out of the exhaust port.

**16.** An oven as recited in claim 15, in which the exhaust fan assembly further draws ambient air through the exhaust chamber.

**17.** An oven as recited in claim 16, in which:

- a gap is defined between the door member and the outer housing assembly when the door member is in the closed position; and

when the door member is in the closed position, the door member engages the outer housing assembly such that fluid flow is substantially prevented through a first portion of the gap, and

the vent opening is defined by a second portion of the gap.

- 18. An oven for processing food, comprising:
  - a housing assembly comprising
    - an outer housing assembly defining a main chamber and an outer access opening,
    - an inner housing assembly arranged within the main chamber, where the inner housing assembly comprises
      - an inner housing member defining an inner chamber and an inner access opening, where a ratio of the bulk volume of the inner housing member to the volume of the food heating chamber is within a range of 1:5.5 to 1:8, and
      - a baffle member arranged to divide the inner chamber into a food heating chamber and an air heating chamber, where the baffle member defines an inlet opening and an outlet opening, and
      - a door member rotatably attached to the outer housing assembly;
    - a blower fan assembly at least partly disposed within the air heating chamber;
    - the outer access opening and the inner access opening at least partly align to define an access port;
    - the door member rotates between
      - an open position in which the inner chamber is accessible through the access port, and
      - a closed position in which the inner chamber is not accessible through the access port; and
    - operation of the blower fan assembly causes air to circulate through the inlet opening, the air heating chamber, the outlet opening, and the food heating chamber.

- 19. An oven for processing food, comprising:
  - a housing assembly comprising
    - an outer housing assembly defining a main chamber, an outer access opening, and an exhaust opening,

- an inner housing assembly arranged within the main chamber, where the inner housing assembly comprises
  - an inner housing member defining an inner chamber and an inner access opening, and
  - a baffle member arranged to divide the inner chamber into a food heating chamber and an air heating chamber, where the baffle member defines an inlet opening and an outlet opening, and
  - a door member rotatably attached to the outer housing assembly;
- a blower fan assembly at least partly disposed within the air heating chamber;
- the outer access opening and the inner access opening at least partly align to define an access port;
- the door member rotates between
  - an open position in which the inner chamber is accessible through the access port, and
  - a closed position in which the inner chamber is not accessible through the access port;
- the housing assembly defines a vent opening for allowing fluid flow between the food heating chamber and the exhaust opening;
- operation of the blower fan assembly causes air within the air heating chamber to circulate through the inlet opening, the air heating chamber, the outlet opening, and the food heating chamber; and
- a ratio of an interior surface area of the food heating chamber to areas of the return inlet opening, the outlet opening, and the vent opening is approximately within a range of 40:1:0.6:0.16 to 50:1:0.85:0.28.

- 20. An oven as recited in claim 19, further comprising an exhaust fan assembly supported relative to the outer housing assembly, where operation of the exhaust fan assembly draws at least a portion of any fluid exiting the food heating chamber through the vent port and out of the exhaust port.

\* \* \* \* \*