



(86) Date de dépôt PCT/PCT Filing Date: 2002/12/12

(87) Date publication PCT/PCT Publication Date: 2003/06/19

(85) Entrée phase nationale/National Entry: 2004/06/03

(86) N° demande PCT/PCT Application No.: US 2002/039995

(87) N° publication PCT/PCT Publication No.: 2003/049871

(30) Priorité/Priority: 2001/12/13 (60/340,699) US

(51) Cl.Int.<sup>7</sup>/Int.Cl.<sup>7</sup> B05C 5/00, G03C 1/74

(71) Demandeur/Applicant:  
DOW GLOBAL TECHNOLOGIES INC., US

(72) Inventeur/Inventor:  
GUEGGI, MARKUS, CH

(74) Agent: SMART & BIGGAR

(54) Titre : PROCEDE ET APPAREIL DE COUCHAGE PAR VOILE

(54) Title: METHOD AND APPARATUS FOR CURTAIN COATING

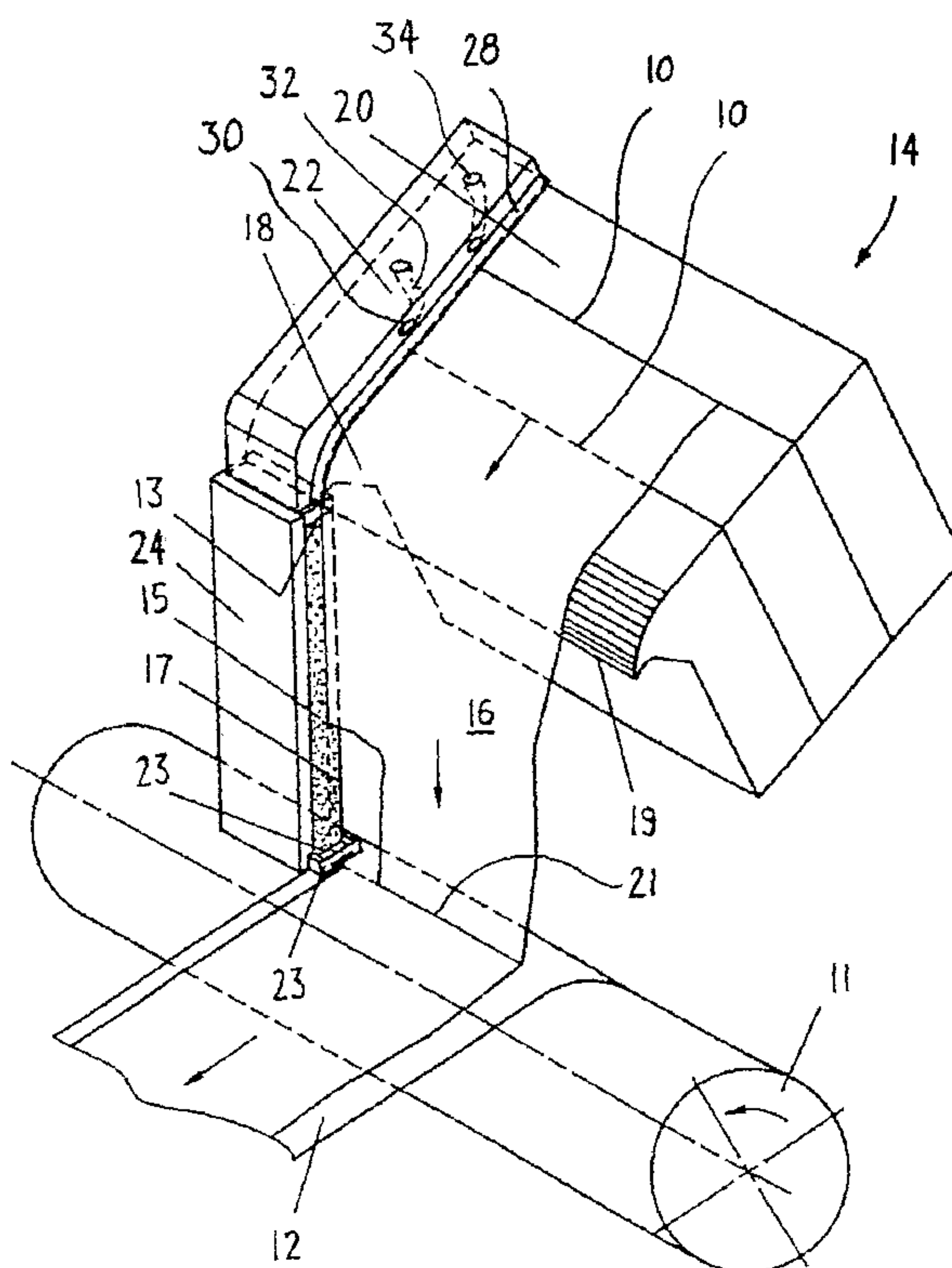

(57) Abrégé/Abstract:

A method and apparatus for curtain coating of a moved substrate, particularly for high-speed curtain coating of a continuous paper web substrate, wherein a substrate (12) is moved below a hopper means (14), provides one or more liquid coating materials in the form of a free-falling curtain (16) impinging the substrate at a dynamic wetting line. (21) Edge guide elements (22, 24) are used for stabilizing the width and equalizing the flow speed of the coating curtain and allowing disturbance free provision of an auxiliary liquid (13) as well as practically compels removal of the auxiliary liquid (23) whilst preventing the forming of solidification on the edge guide elements. An auxiliary liquid is injected (32) essentially parallel to the flow direction of the coating film at an edge of the coating film whilst moving along a slide of said hopper arrangement.

## (12) INTERNATIONAL APPLICATION PUBLISHED UNDER THE PATENT COOPERATION TREATY (PCT)

(19) World Intellectual Property Organization  
International Bureau(43) International Publication Date  
19 June 2003 (19.06.2003)

PCT

(10) International Publication Number  
WO 03/049871 A1

- (51) International Patent Classification<sup>7</sup>: B05C 5/00, G03C 1/74
- (21) International Application Number: PCT/US02/39995
- (22) International Filing Date:  
12 December 2002 (12.12.2002)
- (25) Filing Language: English
- (26) Publication Language: English
- (30) Priority Data:  
60/340,699 13 December 2001 (13.12.2001) US
- (71) Applicant (for all designated States except US): DOW GLOBAL TECHNOLOGIES INC. [US/US]; Washington Street, 1790 Building, Midland, MI 48674 (US).
- (72) Inventor; and  
(75) Inventor/Applicant (for US only): GUEGGI, Markus [CH/CH]; Chemin Foret 9, CH-1723 Marly FR (CH).
- (74) Agent: HAYHURST, Paul, D.; The Dow Chemical Company Intellectual Property, P.O. Box 1967, Midland, MI 48641-1967 (US).
- (81) Designated States (national): AE, AG, AL, AM, AT, AU, AZ, BA, BB, BG, BR, BY, BZ, CA, CH, CN, CO, CR, CZ, DE, DK, DM, DZ, EC, EE, ES, FI, GB, GD, GE, GH, GM, HR, HU, ID, IL, IN, IS, JP, KE, KG, KR, KZ, LC, LK, LR, LS, LT, LU, LV, MA, MD, MG, MK, MN, MW, MX, MZ, NO, NZ, OM, PH, PL, PT, RO, RU, SD, SE, SG, SK, SL, TJ, TM, TN, TR, TT, TZ, UA, UG, US, UZ, YU, ZA, ZM, ZW.
- (84) Designated States (regional): ARIPO patent (GH, GM, KE, LS, MW, MZ, SD, SL, SZ, TZ, UG, ZM, ZW),

[Continued on next page]

(54) Title: METHOD AND APPARATUS FOR CURTAIN COATING

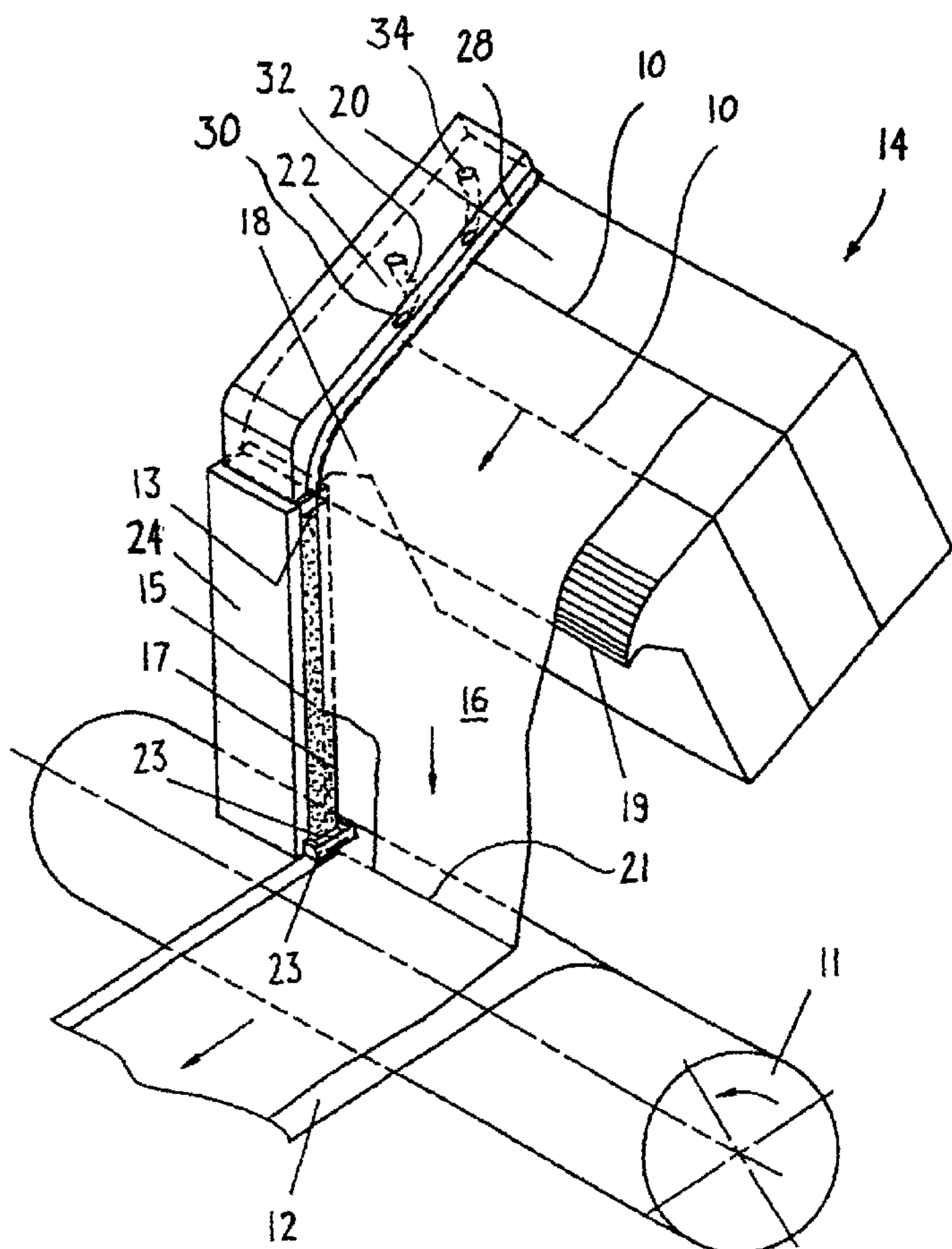

(57) Abstract: A method and apparatus for curtain coating of a moved substrate, particularly for high-speed curtain coating of a continuous paper web substrate, wherein a substrate (12) is moved below a hopper means (14), provides one or more liquid coating materials in the form of a free-falling curtain (16) impinging the substrate at a dynamic wetting line. (21) Edge guide elements (22, 24) are used for stabilizing the width and equalizing the flow speed of the coating curtain and allowing disturbance free provision of an auxiliary liquid (13) as well as practically complete removal of the auxiliary liquid (23) whilst preventing the forming of solidification on the edge guide elements. An auxiliary liquid is injected (32) essentially parallel to the flow direction of the coating film whilst moving along a slide of said hopper arrangement.

  
 WO 03/049871 A1

**WO 03/049871 A1**



Eurasian patent (AM, AZ, BY, KG, KZ, MD, RU, TJ, TM),  
European patent (AT, BE, BG, CH, CY, CZ, DE, DK, EE,  
ES, FI, FR, GB, GR, IE, IT, LU, MC, NL, PT, SE, SI, SK,  
TR), OAPI patent (BF, BJ, CF, CG, CI, CM, GA, GN, GQ,  
GW, ML, MR, NE, SN, TD, TG).

*For two-letter codes and other abbreviations, refer to the "Guidance Notes on Codes and Abbreviations" appearing at the beginning of each regular issue of the PCT Gazette.*

**Published:**

— *with international search report*

## METHOD AND APPARATUS FOR CURTAIN COATING

### Field of the invention

The present invention relates to a method and apparatus for curtain coating of a continuously moving substrate with one or more simultaneously applied layers of liquid coating materials, and, more particularly to a method and apparatus for curtain coating involving a curtain edge guide for stabilizing a coating curtain.

### Background of the invention

Mainly in the field of manufacture of photographic papers or coated films, curtain coating methods and apparatus are widely known and used. Typically a continuous web or sheets are continuously moved below a coating hopper. One or more liquid compositions are provided from a hopper arrangement in the form of a liquid curtain.

For the manufacture of photographic papers, liquid compositions are used of relatively low viscosity,

generally less than about 150 cP (centipoise), most in the range from about 5 to about 100 cP.

The manufacture of photographic papers is a tremendously difficult art requiring extremely accurate control. The practical use of curtain coating provides a number of difficulties coming with a need for an extremely uniform coating on the one hand and a need for coating of substrates in form of a continuous web at high speeds on the other hand.

A number of problems associated with curtain coating have been addressed in the prior art and many proposals have been made to overcome such problems.

Besides obtaining a free-falling curtain having uniform curtain characteristics over its width perpendicular to the moving direction of the substrate, one of the most often addressed problems for coating at speeds higher than approximately 150 m/min is the displacement or deformation of the curtain by the air which is carried along the uncoated substrate due to friction. That air is carried along with the moving substrate to the coating point which designates the location where the coating liquid first contacts the substrate. In the curtain coating process this location has the form of a line across the substrate and is referred to as the dynamic wetting line. The area near the substrate where the air is in motion due to friction is called the boundary layer.

It has further been found to be important to stabilize the edge regions of the free falling curtain to prevent narrowing of the curtain due to surface tension of the coating liquid.

Another drawback coming with an unguided curtain is the formation of edge regions on the coated web having greater coating thickness than the remainder of the web, which is generally undesirably and provides for a need to cut off or remove the edge region of the coating layer or web and deposit the same, as a uniform coating is normally required to meet the expected quality standards.

Consequently, many attempts have been made to overcome the drawbacks and improve coating performance in the curtain coating of substrates.

One of the problems associated with guiding of the curtain edge is described for instance in US 5,895,687 to Kondo et al. originating from the so called "tea-pot effect" or "tea-pot phenomena." The tea-pot phenomena may be observed with regard to a coating solution which flows down along the slide surface of the coating hopper or die, and is just about to fall from the tip of a lip of the coating hopper: the coated liquid curtain layer does not fall in the vertical direction due to a flow speed variation of the coating solution over its thickness, causing the curtain to fall while it is curved towards the hopper.

Kondo et al. propose to provide an edge guide means for the coating curtain wherein the edge guide has a curved cross sectional shape preferably in the form according to the tea-pot phenomena. Although it is acknowledged in US 5,895,687 that a conventional flat plate type edge guide stabilizes a curtain layer, it is described as being disadvantageous and providing a thick edge layer formed on the coated substrate due to an increased contact area between the flat plate type edge guide and the coating liquid.

With reference to Japanese Patent Application Open to Public Inspection No. 99668/1989 it is stated that providing for side solutions flowing on the edge region of the curtain would be disadvantageous because the side solution is accumulated on each end portion of the curtain, resulting in an excessively thick layer on both edges of the coated substrate.

To overcome the latter mentioned problem EP 0 740 197 A1 discloses an edge guide for a coating curtain having a dosing slot at the top and in the region of the tip of the lip of the coating hopper for providing a side flow to reduce disturbances of the free-falling coating curtain due to an inhomogeneous velocity profile over the width of the curtain. With dry edge guides a problem is reported that the falling velocity of the curtain in the edge region contacting the edge guide tends to zero because of the friction and adhesion of the curtain edge on the edge guide. Consequently, an inhomogeneous coating will be

obtained on the substrate web in the region of the curtain edge and it was often proposed in the prior art to involve a coating curtain being wider than the substrate to be coated, thus, to provide coating solution in excess. Of course, such an approach is economically unattractive because a part of the coating solution is lost and the machinery is soiled and therefore needs frequent interruptions of the manufacturing process for cleaning operations.

The equipment proposed in EP 0 740 197 A1 comprises additionally to the wetting guiding edge a cutter and suction arrangement at the bottom of the guiding edge cutting off the outermost edge region of the curtain contaminated with a side flow, which may comprise of water or a water-base composition. The outermost edge region and the side flow is removed by a suction arrangement at the bottom of the edge guide.

Further, it is known from DE 197 35 588 A1 to provide a coating curtain from a slot nozzle to an edge guide element, formed integrally with the slot nozzle arrangement but recessed, and further having an outlet for a side flow of the coating liquid at the top of the edge guide providing an additional flow of coating liquid on the surface of the edge guide. The inclination of the edge guide causes the falling curtain to become narrower at the bottom of the edge guide near the wetting line.

It is further proposed to direct a cooling liquid through the interior of the edge guide so that the edge guide is held at a temperature of about 15°C below the temperature of the coating liquid. This measure is proposed to prevent the coating composition from solidifying on the surface of the edge guide. The edge region of the curtain is cut off by a cutter means and drained away. In one embodiment it is proposed to curve surface of a cutter means being in contact with the remaining curtain parts to expand the curtain downwards the cutting means to prevent formation of edge regions on the coated substrate having a thickness different from the remainder of the coated substrate.

The disclosure of US 5,763,013 to Devine et al. addresses the problem that earlier proposed arrangements for removing the edge region of the curtain by cutting means and a vacuum source for sucking off the cutting off edge portion liquid provides further problems with respect to the reliability of the manufacturing process due to solidification causing at least partial plugging of the vacuum channels. This is reported to cause particular problems if the coating composition includes a setting polymer such as bone gelatin and the contact surfaces of the vacuum means have temperatures below ambient temperatures. Devine proposes providing of an additional flushing liquid directly to the vacuum means so that the liquid from

the edge region of the curtain will reliably be drained from the cutting means.

EP 0 907 103 A1 proposes to provide a curtain edge guiding means comprising a porous layer and lubricant liquid supply means arranged in connection with a porous layer so that the lubrication liquid is provided over nearly the full length of the edge guiding means. More particularly, it is proposed to supply the liquid along the guiding edge at a velocity which is the same as the falling velocity of the curtain at the respective location along the guiding edge. The bottom region of the guiding edge is proposed to comprise a solid material easily wetted having a surface inclined towards the curtain edge by  $1^{\circ}$  to  $5^{\circ}$  towards the center of the curtain and having a suction slot at the outermost bottom having a collecting edge protruding over the surface towards the curtain to ease removal of the lubrication liquid and outermost edge parts of the coating curtain.

US 5,906,865 to Ellermeier et al. reports breakage of the coating curtain as the predominant limiting factor with respect to coating speed and continuous operation of a curtain coater. Wetting of edge guides or curtain holders with an auxiliary liquid is reported to be the most proposed measure to overcome the problems originating from turbulence in the proximity of the curtain edge. Separating devices or cutting means often proposed comprise essentially a flat cantilevered blade. This blade projects from a vacuum

housing and interrupts the free fall of the curtain in the immediate vicinity of and parallel to the substrate to be coated. The interruption occurs just before the curtain lands. The blades need to be thin and sharp. According to a number of proposals it is further rinsed on its upper side by cleaning liquid. The stream of cleaning liquid rinses the liquid of the curtain edges out of the coating area. If the curtain edges comprise a gelatin solution, only part of the valuable coating solution is lost but crust may accumulate on the edge of the blade during long operation cycles. This is caused by gelatin residues. Thus, the blade becomes dull. A dull blade cannot satisfactorily prevent a beaded coating on the edge. One of the problems coming with the blade is a flow adhering to the surface of the blade or its underside, generally being unstable. Fundamentally, the cantilevered, sharp edged blade presents an ever-present risk to the operators. Cleaning of the blades can result in injuries and the thin blades can be easily bent and damaged causing interruptions in the coating process both to required cleaning and repair operations.

US 5,906,865 proposes cutting the edge region of the curtain together with a wetting liquid used on a preferably flat edge guide to be cut off by a free jet of a separating liquid, like water, and to drain off the cut edge region of the curtain and any auxiliary liquid used on the edge guide by strong vacuum source before the curtain reaches the substrate to be coated.

It is pointed out that there is no wear on the jet cutting means and no risk for personnel working when the coating process is interrupted.

According to EP 0 567 071 A1 a curtain coating method using a slide hopper includes the supply of an auxiliary liquid in order to eliminate the unevenness of coating thickness produced in both edge portions of a coating film which is formed by causing a free-falling coating film to impinge on a web running continuously. The auxiliary liquid is poured from a position on a distance of no more than 10 mm from a boundary line between guide blades and edge guides in a direction of the guide plates. The quantity of flow of the auxiliary liquid to be poured onto each of the guide blades is not more than 10 cc/min. A guide blade according to this prior art has an inclination of an angle  $\Theta = 10^\circ$  to  $80^\circ$  with respect to a slide plane in order to pour an auxiliary liquid to the side of the coating film on a slide surface. The surface tension of the auxiliary liquid is higher than that of the coating film so that the auxiliary liquid is not attracted to the center of a coating film to thereby make film coating unstable. According to one example of this document the auxiliary liquid has a 2 cP (centipoise) viscosity, 37 dyne/cm surface tension and 4 cc/min supplied quantity. The auxiliary liquid is poured to the upper surface of the guide blade at a position which is at a distance of no more than 10 mm

in the direction from boundary line between the guide blade and the edge guide.

According to EP 0 649 054 A1 a stripe internal edging method and apparatus is disclosed for curtain coating of a support with one or more layers of the liquid coating composition using stripes of the liquid coating composition formed at the edges of the free-falling curtain, the stripes being guided by edge guides which are positioned so that there is an uncoated margin of support at each edge of the support. Liquid is removed from the edges of the free-falling curtain near the point of impingement on the support. The apparatus and method is used especially for curtain coating of very low flow rates per unit width. The apparatus comprises flushing means for issuing liquid from the edge guide to maintain wetting contact with the stripes. The stripe composition is generally an aqueous gelatin solution with appropriate surfactants added to balance the surface tension of the stripe with a top on bottom layers of the curtain. Thickeners may also be used. Stripe viscosity is optimally in the range of 1 to 30 cP (centipoise), especially 5 to 20 cP. The flow rate of the stripe is greater than the minimum possible to achieve a stable curtain along the edge guides. The width of the stripe is at least 3 to 10 mm. A stripe air interface of at least 5 mm is formed before the stripe merges with the main body of the curtain. The stripe is formed by means of a cavity and slot arrangement in which the stripe flows down inclined surfaces before merging

with the main body of the curtain. Means for forming the stripe may be located on the hopper edge pad. Such a pad may be manufactured incorporating an inlet and downwardly directed metering slot for forming the stripe. The metering slot discharges the stripe composition at or near the lip of the hopper. Also the stripe may be guided down the edge guide by lubricating fluid introduced through outlet and slide. The stripe fluid is provided through a conduit and the lubricating fluid which is preferably water is provided through another conduit. The flow rate of the stripes is especially approximately 1.6 cc/cm sec and the stripe viscosity is 8 cP. The surfaces of the stripe should be edged before merging with the main body of the curtain as otherwise the interface between the stripe and the main body of the curtain departs significantly from vertical as the stripe flow rate is increased.

EP 0 850 696 A2 relates to a curtain coating method using an auxiliary solution to stabilize the curtain. The auxiliary solution is to flow down along edge guides at a flow rate between 0.3 cc/min and 3.0 cc/min from each side of solution injecting means. The value of surface tension of the auxiliary solution is greater than or the same as the minimum value of surface tension of the coating solution to restrict the mixture of the auxiliary solution and the coating solution to the minimum. Viscosity of the auxiliary solution is smaller than that of the coating solution. The auxiliary solution is either a gelatin solution of

no more than 3 percent by weight or water. The apparatus comprises slide plates having solution injection outlets supplying the auxiliary solution which flows down to a boundary in the vicinity of the side plates. A flow rate of the auxiliary solution increased up to 3 cc/min makes the force of the curtain shrink smaller gradually, but when the amount of the auxiliary solution exceeded 3 cc/min the change on the curtain disappeared, simply showing the thickened water layer of the auxiliary solution. It is stated in EP 0 850 696 A2 that the more an injecting outlet for the auxiliary solution is located at the downstream side of a curtain the less is any effect, if the injecting outlet is located at a lip which is at the upstream side of the curtain or at a position above that the effect is greater, and where the height for supplying is the same as the coating solution height the effect is at a maximum. Excellent coating with fewer uneven portions can be conducted using an auxiliary solution having a gelatin concentration of no more than 3 percent, or water.

According to EP 0 930 530 A2 a curtain coating method and apparatus for coating at high speed without unevenness to form uniform coatings in multi-layer coating comprises a center line of outlets for discharging auxiliary solution being sloped to the direction in which the coating solution flows down. An angle between the centerline of the outlets and a horizontal line is within 30 degrees. The outlets have a circular diametrical section of 0.4 to 1.5 mm in

diameter. The amount of auxiliary solution discharged from each outlet is 3 to 8 cc/min. A pair of outlets for discharging the auxiliary solution is disposed in the position along each edge part of free-falling curtain and at a fixed distance downward from a hopper lip. The fixed distance is between 0.1 and 1.5 mm. A pressure of the auxiliary solution supply is applied in the width direction of the free-falling curtain. As an auxiliary solution water may be used or water and methanol or a solution comprising water, methanol and gelatin.

US 5,976,251 discloses edge guides for curtain coating apparatus and delivering devices and lubricating liquid for use with curtain coating apparatus. A dual wire edge guide is supplied with lubricating liquid without creating a stationary wave in the curtain coating avoiding non-uniformities. Lubricating and flushing liquid is supplied through a straight horizontal conduit of constant cross sectional area with an axis lying in a plane parallel to that of the curtain. The outlet of the conduit is in nominal contact with the dual wires. The breadth of the outlet is from about 2 to 4 mm. A land is provided surrounding the outlet for lubricating liquid lying substantially in a vertical plane perpendicular to a hopper lip, tapering downwards and terminating from about one centimeter of the hopper lip. The flow rate of the lubricating liquid may vary between 0.3 and 0.5 cc/sec and the lubricating liquid can be water or a solvent for the coating composition.

Although many approaches have been made in the prior art to overcome the drawbacks and problems coming with the use of a curtain coating process, in particular at high coating speeds, there are still remaining drawbacks effecting the quality and cost effectiveness of curtain coating methods, in particular with respect to high speed curtain coating of continuous paper web substrate.

#### Summary of the invention

It is therefore an object of the invention to provide an improved curtain coating method and apparatus particularly for high-speed curtain coating of a substrate, more particularly for high-speed curtain coating of a continuous paper web substrate, more particularly in connection with a coating liquid having a relatively high viscosity compared to the coating liquids used for the manufacture of photographic papers, that is having a low shear viscosity of generally well above 1.5 Pa.s.

Briefly stated, these and other features, objects and advantages are obtained by providing a method for curtain coating of a moved substrate like a paper web wherein a substrate is moved below a hopper means providing one or more liquid coating materials in the form of a free-falling curtain impinging the substrate

at a dynamic wetting line wherein improved edge guide elements are used for stabilizing the width and equalizing the flow speed of the coating curtain and allowing disturbance free provision of an auxiliary liquid as well as practically complete removal of the auxiliary liquid whilst preventing the forming of solidification on the edge guide elements.

Further improvements obtained by the side and curtain edge guides according to the invention are increased falling velocity on the curtain edge guide, the prevention of wetting disturbances in the edge region of the coating film air entrainment, prevention of coating film irregularities caused by the Marangoni-effect (a gradient of surface tension from low to high displaces the materials) and reducing the Teapot-effect (a curved trajectory of the liquid curtain which may deviate substantially from the vertical trajectory) with respect to the edge guide in multi-layer coating.

In a preferred embodiment of the invention, the method is provided with the step of injecting an auxiliary liquid essentially parallel to the flow direction of a coating film at an edge of the coating film whilst moving along a hopper slide of the hopper means.

An important advantage of the auxiliary liquid which is added along the slide is to receive a lower friction at the edges and to hold the edges cleaner. This

results in an even and equal film thickness of the coating film.

More preferably, an auxiliary fluid is injected into the edge region of a coating film for each coating fluid layer.

The location of injection should be placed somewhat upstream, or just at, or somewhat downstream of a slot outlet on the hopper slide for each coating liquid, and the distance of the injection location above the slide may be adjusted to the coating layer concerned.

In a preferred embodiment of the invention water or a water-based composition is proposed as the auxiliary fluid, preferably comprising an agent for increasing surface tension and/or KCl (potassium chloride) or a similar salt.

It may be also useful to use an auxiliary fluid comprising a wetting agent and/or a thickening agent.

The preferred injection speed for the auxiliary fluid is about the same as of the respective liquid layer on the slide, however with less or without any solid ingredients, and an injection flow of about 0.1 to 0.7 liters per hour is preferred for each layer of the coating film, or 0.5 to 3 liters per hour for the total of auxiliary liquid injected.

The invention provides a slide edge guide for a curtain coater having at least one contact area of its surface directed towards a coating film, which contact area has one or more injection outlets for auxiliary liquid connected to outlet channels having a configuration with respect to the edge guide so that the auxiliary liquid leaves the channel at an direction essentially parallel to the edge guide.

In a preferred embodiment at least one of the outlet channels has an cross sectional area of about 1.5 mm<sup>2</sup>.

It is further preferred to have a multiplicity of injection outlets provided in each edge guide, having a distance to each other, most preferred about the same distance, and may be arranged at about the same or a varying distance from the hopper slide surface. Further, the injection outlets may be arranged at a certain distance or space from each hopper slot for the coating liquid supply.

#### Brief description of the drawings

Figure 1 is a schematic overview showing generally a curtain coater arrangement as known from the prior art;

Figure 2 is a perspective view of a curtain coater having a slide edge guide arrangement according to the invention; and

Figure 3 is a top view of a slide edge guide according to the invention.

Detailed description of the invention

Figure 1 shows the main parts of a curtain coater as known from the prior art and generally involved with an improved method and apparatus according to this invention. A conventional curtain coater has means, preferably in form of a backing roller 11, for forwarding separate sheets or a continuous web 12 as a substrate to be coated. The web 12, which may comprise paper, is forwarded along the backing roller 11 through the curtain coater.

A hopper means 14 is located generally above the backing roller 11. Various forms of hopper means 14 are known, generally providing a curtain 16 of a coating liquid 18 free falling over a distance forwarded over a lid 19 or any other suitable means. The coating curtain 16 is moved towards the substrate 12 by gravity force and impinges on the substrate web 12 along a line generally perpendicular to the moving direction of the substrate 12. The line is generally below the lid 19 but moving relatively to the substrate web 12 when in motion and therefore called the dynamic wetting line 21.

The coating film 18, which may comprise several different layers of liquid, is provided through one, or more in case of a multi-layer coating film 18, slot

type openings 10 onto a so called slide 20 of the hopper means 14.

For the purpose of this application, the area of the coating film 18 oriented in a direction towards the substrate web 12 is called downstream, whilst the coating film 18 towards the slot 10 is called upstream.

The slide width is limited by slide edge guides 22 which generally provide for the width of the coating film 18. Downstream of the slide edge guide 22 and generally along the distance where the coating curtain is free falling, curtain edge guides 24 are provided to hold the coating curtain 16 until it impinges on the substrate web 12. Curtain edge guides 24 may comprise a supply slot 13 for providing a lubricant onto a slide area 15 generally limited by the back edge 17 of the curtain edge guide 24 and may include means 23 for removing the lubricant to prevent spillage onto the substrate web 12 or into the curtain 16.

The curtain edge guide 24 comprises a mounting part for smoothly fitting to corresponding slide edge guide 22. Preferably, the contact region between the edge guides 22 and 24 is formed to smoothly fit with each other such that the surfaces of either edge guides 22 and 24 form a planar junction without projections or recesses disturbing the flow of the coating film and/or any auxiliary liquid so that any turbulence in

the fluids is prevented which could provide for streaks or the like in the coating on the web 12.

For best performance of the curtain coating process it may be advantageous to provide a small space 26 at the slide 20 between the outermost edge of a supply slot 10 and the slide edge guide 22 for the auxiliary liquid. The slide edge guide 22 shown in figure 2 comprises at least one contact area 28 of its surface directed towards the coating film 18, which contact area 28 has one or more injection outlets 30 for auxiliary liquid connected to outlet channels 32 having a configuration with respect to the slide edge guide 22 so that the auxiliary liquid leaves each channel 32 at an direction essentially parallel to the slide edge guide 22 as indicated in figure 3.

The injection speed of the auxiliary liquid should be as close as possible to the speed of the coating film along the slide to make the additional liquid supply as soft as possible without disturbing the flow of the coating film.

It is preferred that the outlet channels 32 have a cross sectional area of about  $1.5 \text{ mm}^2$ . The injection outlets 30 provided in each slide edge guide are spaced from each other at about equal distance. Further, the injection outlets 30 may be arranged at a certain distance from each hopper slot 10 for supply of coating liquid or film 18. The channels 32 preferably are routed through the slide edge guide 22

towards connecting bores 34 for connection of supply lines for the auxiliary fluid (not shown).

Where this invention has been described in terms of a preferred embodiment, the present invention can be further modified within the spirit and the scope of this disclosure. This application is therefore intended to cover any variations, uses or adaptations of the invention using its general principles. Further, this application is intended to cover such departures from the present disclosure as come within known or customary practice in the art to which this invention pertains and which fall within the limits of any claims directed to this invention.

### C l a i m s

1. A method for curtain coating of a moved substrate, particularly for high-speed curtain coating of a continuous paper web substrate, wherein a substrate is moved below a hopper means providing one or more liquid coating materials in the form of a free-falling curtain impinging the substrate at a dynamic wetting line, wherein edge guide elements are used for stabilizing the width and equalizing the flow speed of the coating curtain and allowing disturbance free provision of an auxiliary liquid as well as practically complete removal of the auxiliary liquid whilst preventing the forming of solidification on the edge guides elements.
  
2. A method for curtain coating of a moved substrate, particularly for high-speed curtain coating of a continuous paper web substrate, wherein a substrate is moved below a hopper means providing one or more liquid coating materials in the form of a free-falling curtain impinging the substrate at a dynamic wetting line, wherein edge guide elements are used wherein an auxiliary liquid is injected

essentially parallel to the flow direction of the coating film at an edge of the coating film whilst moving along a slide of said hopper means.

3. The method according to claim 2, wherein the auxiliary liquid is injected into the edge region of a coating film for coating fluid layer.
4. The method according to claim 3, wherein the auxiliary liquid is injected into the edge region of a coating film for each coating fluid layer.
5. The method according to claim 2, wherein a water or water-based composition is proposed as the auxiliary liquid, preferably comprising an agent for increasing surface tension and/or KCl (potassium chloride) or a similar salt.
6. The method according to claim 5, wherein an auxiliary agent comprising a wetting agent and/or a thickening agent is added to the water or water-based composition.
7. The method according to claim 2, wherein the auxiliary liquid is about the same as of the respective liquid layer of the coating film on the slide for coating the substrate, however with less or without any solid ingredients.
8. The method according to claim 2, wherein the auxiliary liquid has an injection flow of about 0.1

- to 0.7 liters per hour for each liquid layer of the coating film.
9. The method according to claim 2, wherein the auxiliary liquid has an injection flow of about 0.5 to 3 liters per hour for the total of auxiliary liquid injected.
  10. The method according to claim 2, wherein the injection speed of auxiliary liquid is as close as possible to the speed of the coating film along the slide.
  11. An apparatus for curtain coating of a moved substrate, particularly for high-speed curtain coating of a continuous paper web substrate, with a hopper means providing one or more liquid coating materials in the form of a free-falling curtain impinging the substrate at a dynamic wetting line and with edge guide elements wherein said edge guide elements are arranged along a slide of the hopper means having at least one contact area of its surface directed towards the coating film, which contact area has one or more injection outlets for auxiliary liquid.
  12. The apparatus according to claim 11, wherein said injection outlets are connected to outlet channels having a configuration with respect to said edge guide elements so that the auxiliary liquid leaves

said outlet channels at a direction essentially parallel to the edge guide elements.

13. The apparatus according to claim 11, wherein a multiplicity of injection outlets provided in each edge guide element.
14. The apparatus according to claim 13, wherein for each liquid layer of the coating film at least one injection outlet is arranged.
15. The apparatus according to claim 13, wherein the multiplicity of injection outlets is arranged at varying distances from the hopper slide surface.
16. The apparatus according to claim 13, wherein the injection outlets are arranged at a small distance or space from each hopper slot for coating liquid supply onto the slide of the coating hopper means.
17. The apparatus according to claim 16, wherein the distance or space is provided at the slide between the outermost edge of a supply slot and the edge guide element for the auxiliary liquid.
18. The apparatus according to claim 11, wherein each edge guide element comprises at least one contact area of its surface directed towards the coating film, which contact area has one or more of said injection outlets for the auxiliary liquid.

19. The apparatus according to claim 12, wherein said outlet channels have a cross sectional area of about 0,5 to 2,5 mm<sup>2</sup>, preferably 1,5 mm<sup>2</sup>.
20. The apparatus according to claim 11, wherein said injection outlets are located close to hopper slots for supply of coating liquid or film.

FIG. 1  
(PRIOR ART)

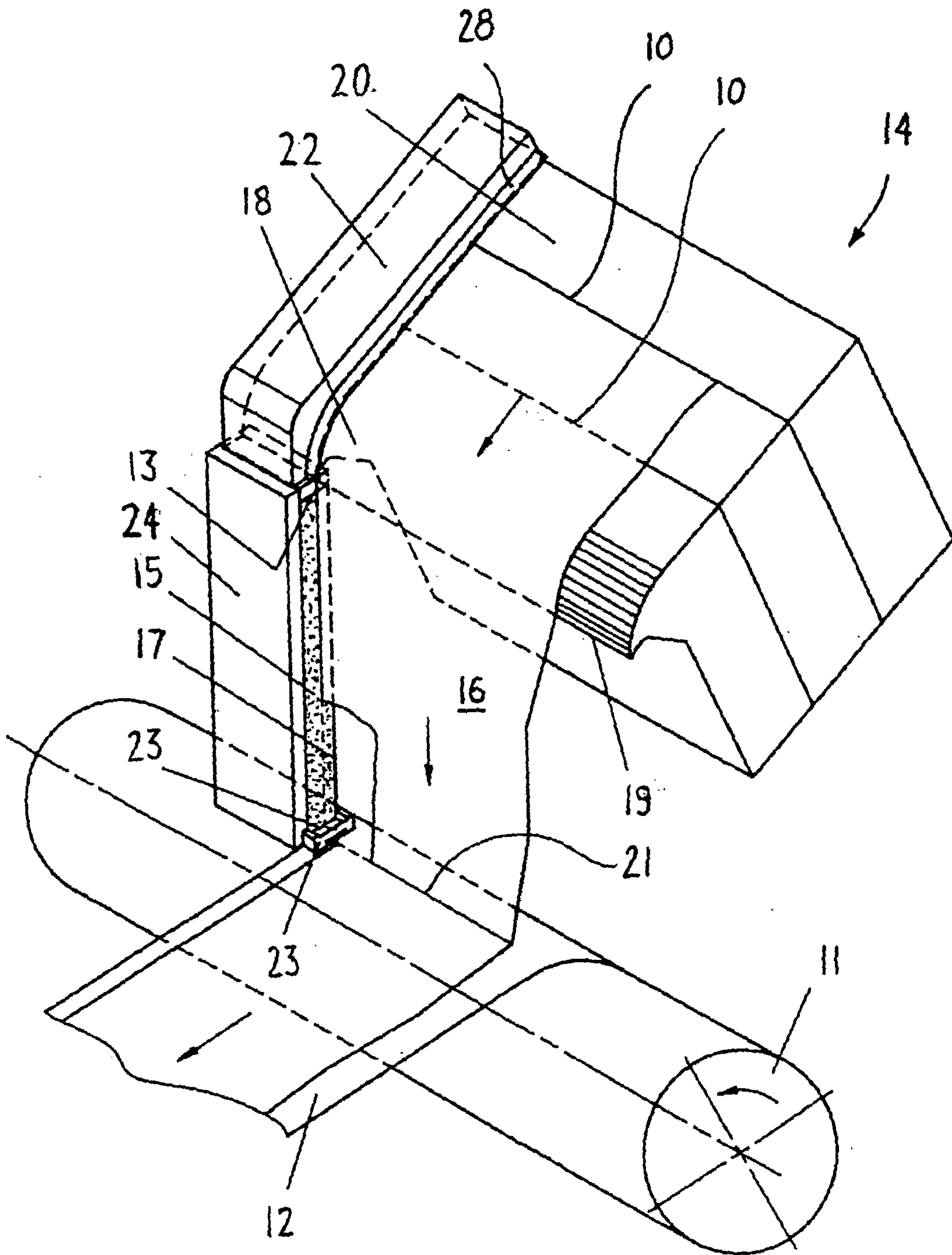
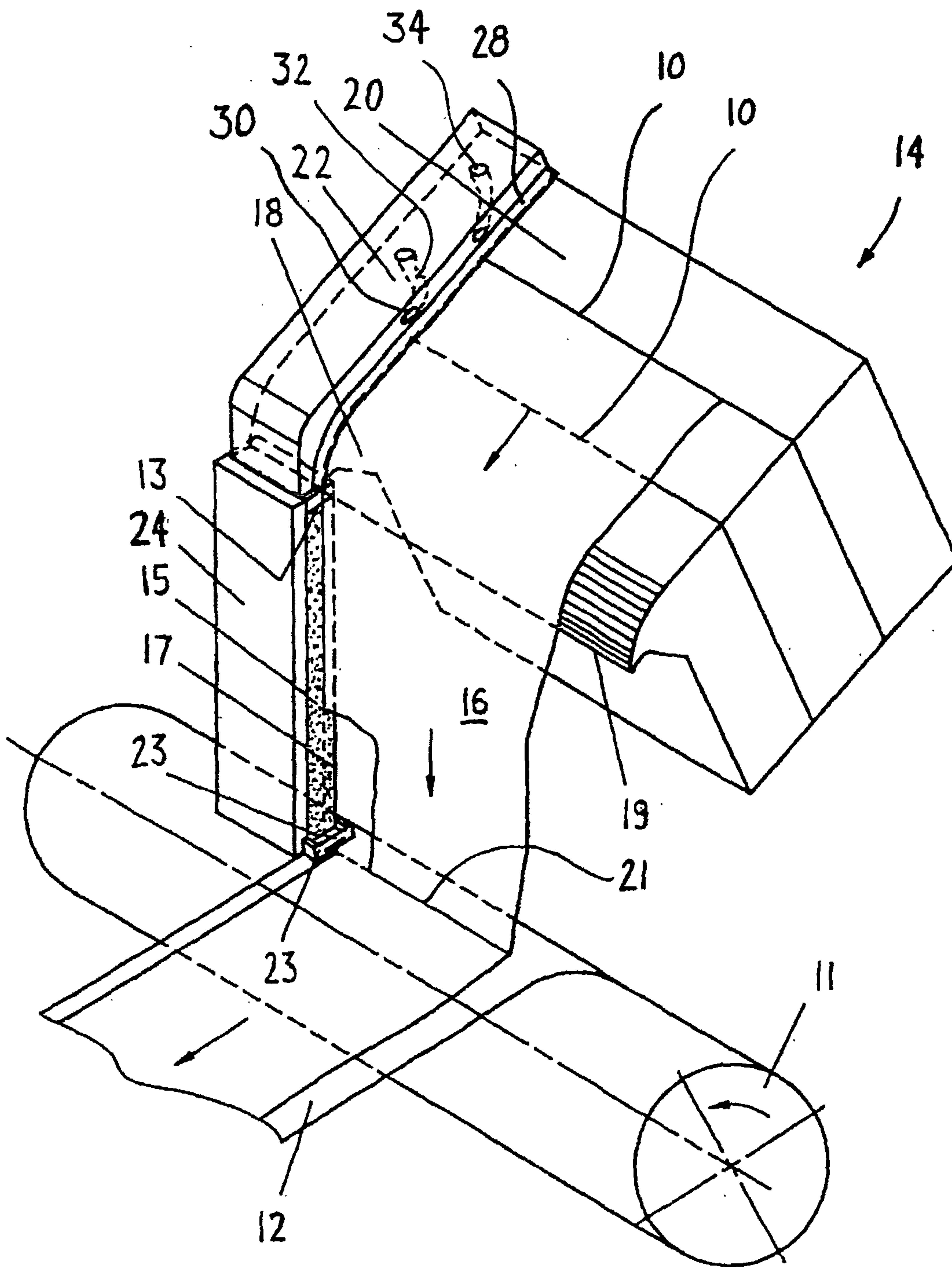

FIG. 2



3/3

FIG. 3

