

[54] **WEFT THREAD INSERTING METHOD AND APPARATUS**

2,072,160 3/1937 Dewas139/125
 3,288,173 11/1966 Golobart.....139/122

[72] Inventor: **Allan William Henry Porter**, Stosswald, Switzerland

FOREIGN PATENTS OR APPLICATIONS

711,511 7/1954 Great Britain.....139/125

[73] Assignee: **Adolph Saurer, Ltd.**, Arbon, Switzerland

Primary Examiner—Henry S. Jaudon
Attorney—Michael S. Striker

[22] Filed: **Nov. 4, 1969**

[21] Appl. No.: **873,996**

[57] **ABSTRACT**

[30] **Foreign Application Priority Data**

Nov. 5, 1968 Switzerland16482/68

Weft threads are inserted into successive warp sheds in opposite directions by a shuttle which has at both ends frictional holding means which can be opened and closed, and frictionally guide in the closed position the weft thread along a tortuous path without clamping the weft thread. The respective trailing holding means receives and holds the inserted weft thread for the next pick and is automatically opened at the end of the same to release this thread at the same time as the previously leading holding means is opened and closed to receive and hold a new weft thread for the subsequent following pick when the leading and trailing positions of the two holding means are reversed.

[52] U.S. Cl.139/125

[51] Int. Cl.D03d 47/24

[58] Field of Search139/116, 122-127, 139/131, 132

[56] **References Cited**

UNITED STATES PATENTS

1,102,110 6/1914 Wahl139/126

10 Claims, 17 Drawing Figures

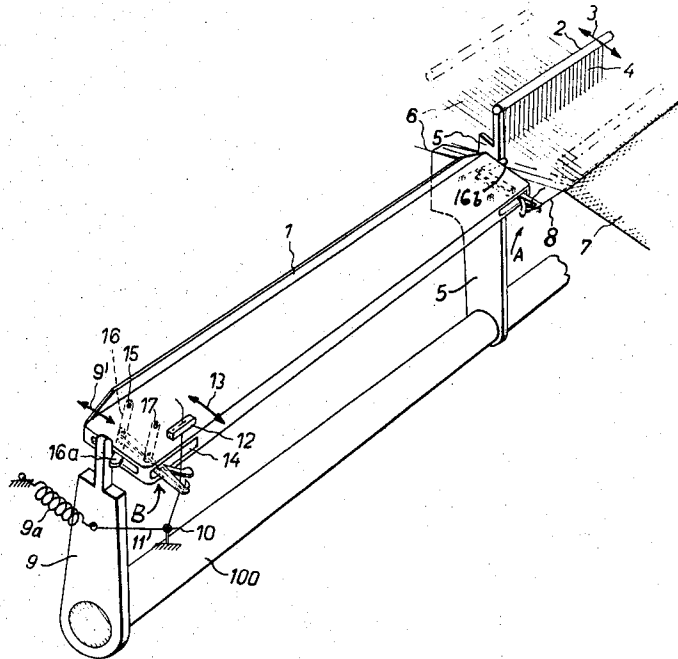

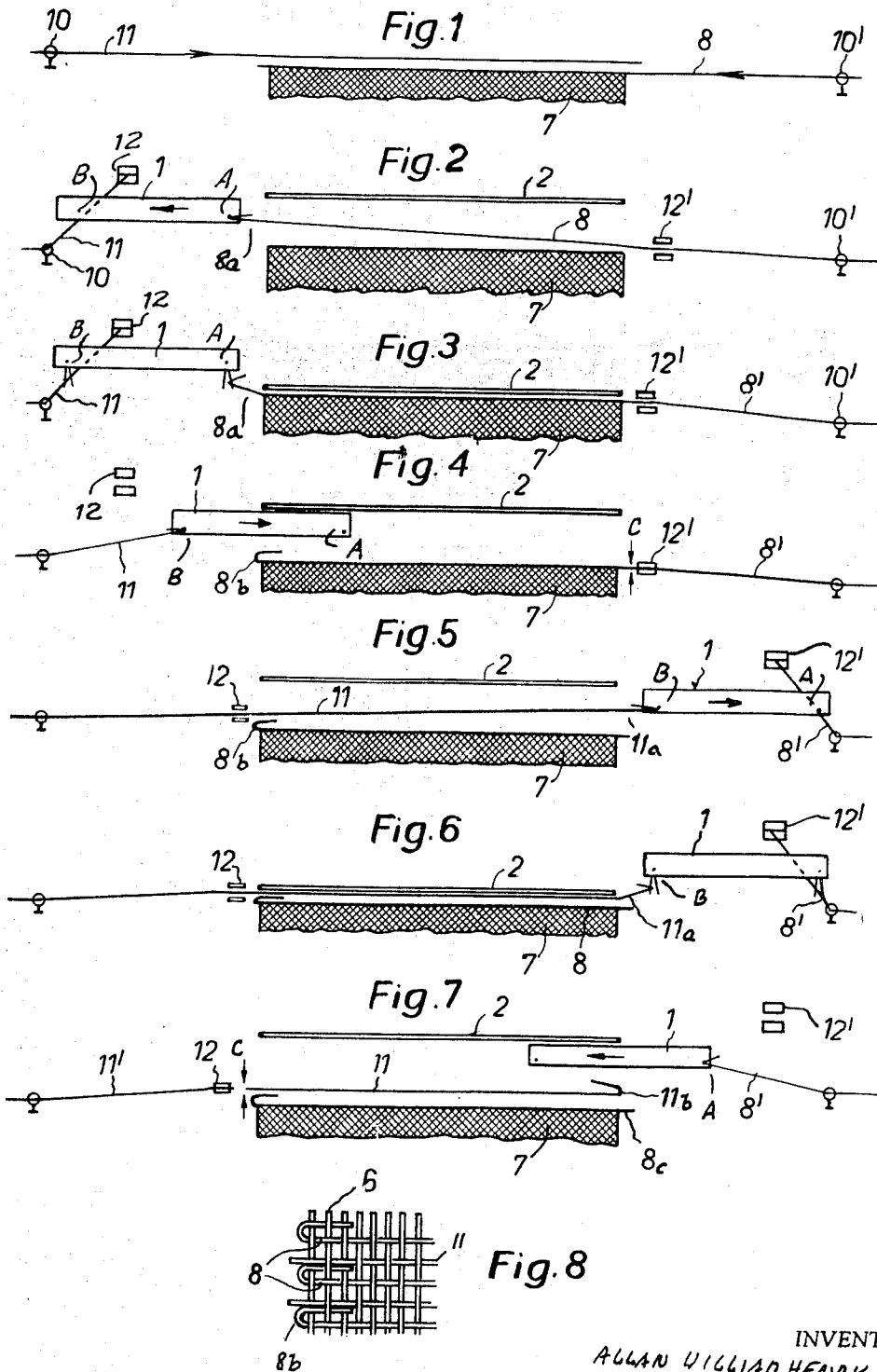

INVENTOR.
ALLAN WILLIAM HENRY PORTER
BY
Michael S. Ste. Lee
Attorney

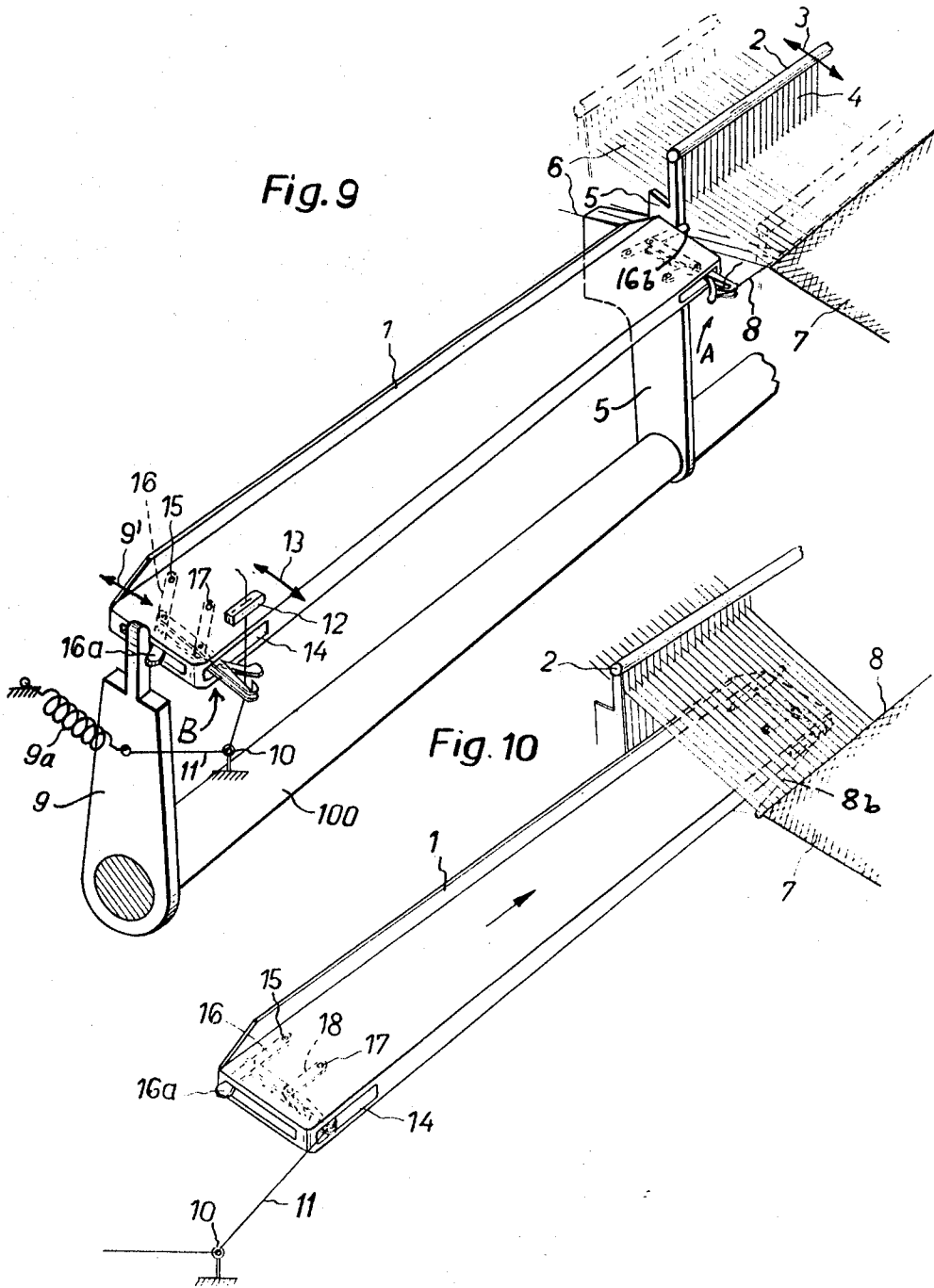

INVENTOR.
AGGAN WILGIAN HENRY PORTER
BY
Alfred J. Hester
Attorney

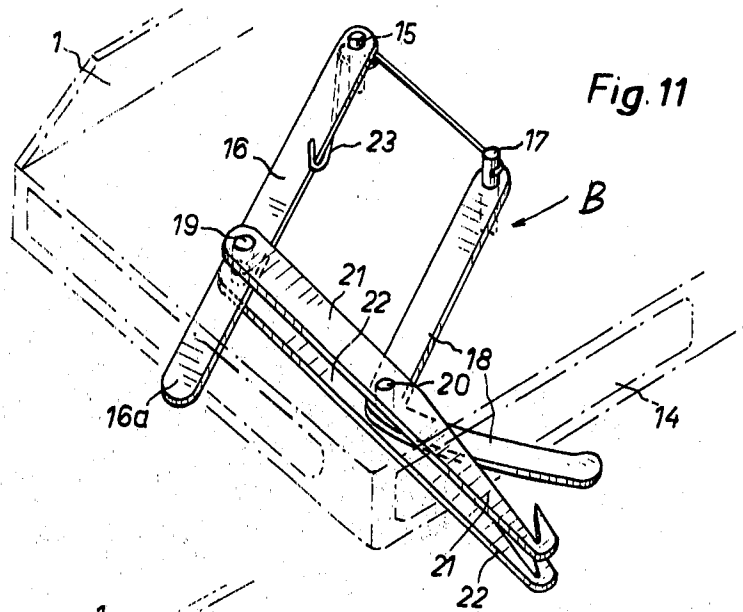

Fig. 11

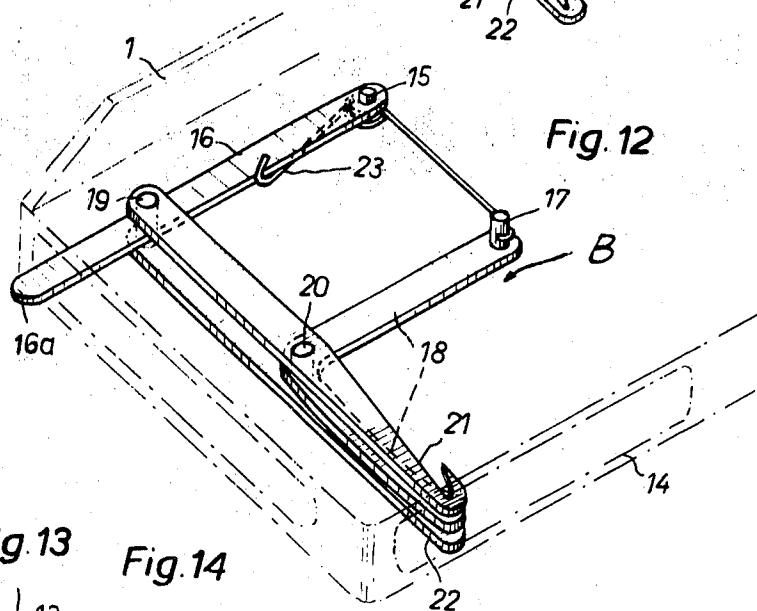

Fig. 12

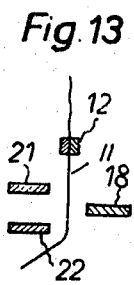

Fig. 13

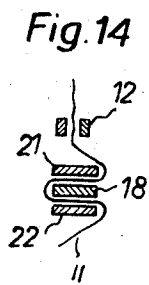

Fig. 14

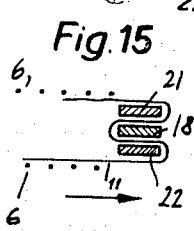

Fig. 15

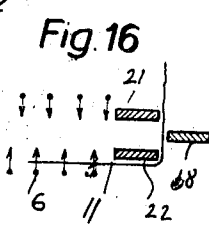

Fig. 16

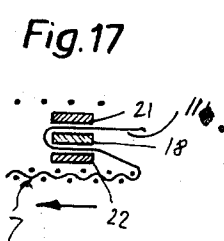

Fig. 17

INVENTOR.
ALLAN VIGLIANI HENRY DORTCH
BY

WEFT THREAD INSERTING METHOD AND APPARATUS**BACKGROUND OF THE INVENTION**

The present invention is concerned with the insertion of weft threads by bobbin-less shuttles which are supplied with the weft thread from supply reels, or are supplied with weft threads having a measured length corresponding to the width of the warp shed.

In accordance with one method of the prior art, a gripper shuttle clamps the end of a weft thread supplied by a supply reel outside of the warp shed, and is picked always from the same side into the successive warp sheds. After completion of the pick, the trailing end of the inserted weft thread is cut off, and the thread ends which project from both sides of the closed warp shed are inserted into the next following opening warp shed for forming a selvage. The insertion of the thread ends requires a special and complicated mechanism.

In accordance with another method of the prior art, a gripper shuttle is used which has two clamping means at the ends thereof. Supply reels for weft threads are provided on either side of the loom outside of the warp sheds, and the gripper shuttle engages the thread always with a clamping means at the leading end, the weft thread being supplied by the supply reel on the same side of the loom where the gripper shuttle is located. When the leading clamping means of the shuttle moves out of the warp shed, the leading clamping means is opened by a special device, so that it is practically impossible to achieve release of the weft thread after the pick of the shuttle through the warp shed for the shuttle is stopped in the shuttle box, so that weft thread ends of different length project from the closed warp shed.

In accordance with another method of the prior art, a gripper shuttle is used which has only one clamping means which is always trailing during the picks of the shuttle. In order to insert weft threads supplied by supply reels on both sides of the loom, or weft thread of a measured length, the shuttle is turned on either side of the loom and warp shed with the shuttle box 180°, before being picked in the opposite direction through the next following opening of the warp shed. The reversible shuttle box construction is complicated.

It is the object of the invention to overcome the disadvantages of the prior art, and to provide a weft thread inserting method requiring a very simple apparatus, and assuring reliable insertion of a weft thread.

Another object of the invention is to provide on both sides of a bobbin-less shuttle, holding means which, during picks in opposite direction, alternately lead and trail.

Another object of the invention is to use the trailing holding means for the insertion of a weft thread into a warp shed, so that the leading holding means is ready to engage a new weft thread which is inserted during movement of the shuttle in the opposite direction through the next following warp shed.

SUMMARY OF THE INVENTION

In accordance with the invention, a shuttle having holding means for weft thread at both ends, holds the weft thread with the trailing holding means and inserts the same into the warp shed so that after the pick the trailing holding means and the weft thread held by the same are located directly adjacent the edge of the fabric and warp shed where the shuttle emerges from the warp shed. In this position, the weft thread may be released to from a thread end at the warp shed edge which may be cut off, or the weft thread end is inserted into the next following warp shed by the shuttle which is picked in the opposite direction through the respective next following warp shed. When the weft thread end is thus bent over and inserted into the next following warp shed, the now leading holding means is opened to allow the thread to be drawn by the beat up of the reed and is subsequently in its shortened length over more gripped and carried and released through the reduction in friction force in the newly formed warp shed thus forming a closed selvage.

The preferred method of the invention comprises the steps of picking a shuttle having holding means at either end, alternately in opposite directions through successive warp sheds to positions in which the respective trailing pick a new weft thread to the holding means leading in the direction of the completed pick; closing said leading holding means from the remainder of the old pick and opening the trailing holding means to receive the new pick or weft thread. In this manner, during the following pick in the opposite direction, when the trailing holding means becomes the leading holding means and the leading holding means becomes the trailing holding means, the old weft thread is pulled out of the open holding means, and the new weft thread is inserted by the now trailing closed holding means into the next following warp shed.

In accordance with one method of the invention, the holding means are opened and closed by the reciprocating reed of the loom.

An apparatus according to the invention by which the method of the invention is advantageously carried out, has holding means including a plurality of guide members which frictionally hold the weft thread which is several times deflected about adjacent guide members when the same are in a closed position. When the guide members are opened, and the guide members move apart in a scissor-like movement, an angular gap is formed into which a new weft thread can be placed, which is then frictionally held, without being clamped, by the guide members which, in the closed position, have on opposite sides staggered lateral faces bending the weft thread alternately in opposite directions.

A preferred weft inserting arrangement according to the invention comprises a shuttle having first and second holding means at the ends thereof, respectively, each holding means including a plurality of guide members movable between an open position forming a gap for receiving and releasing a weft thread, and a closed position for deflecting a weft thread along a tortuous path so that the weft thread frictionally engages the guide members and is held by the same without being clamped. Actuating means are located at both sides of the loom for moving the guide members of the two holding means between the opened and closed positions.

In accordance with the invention, the weft thread is retained by light resilient means and is frictionally held by the guide members during the pick.

In the preferred embodiment of the invention, the actuating means include means reciprocating the reed for opening and closing the leading and trailing holding means outside of the warp shed.

The novel features which are considered as characteristic for the invention are set forth in particular in the appended claims. The invention itself, however, both as to its construction and its method of operation, together with additional objects and advantages thereof, will be best understood from the following description of specific embodiments when read in connection with the accompanying drawing.

BRIEF DESCRIPTION OF THE DRAWING

FIGS. 1 to 7 are fragmentary schematic views illustrating successive operational positions of an apparatus carrying out a method according to the invention;

FIG. 8 is a fragmentary plan view illustrating a selvage made in accordance with the method of FIGS. 1 to 7;

FIG. 9 is a fragmentary prospective view illustrating a shuttle, and associated parts of the apparatus in a first operational condition at the end of a pick;

FIG. 10 is a fragmentary perspective view corresponding to FIG. 9, but illustrating another operational position of the shuttle at the beginning of the next following pick into a warp shed;

FIG. 11 is a fragmentary perspective view illustrating on an enlarged scale, a holding means at one end of the shuttle in the open position;

FIG. 12 is a fragmentary perspective view corresponding to FIG. 11, but illustrating the holding means in the closed position; and

FIGS. 13, 14, 15, 16, and 17 are fragmentary schematic sectional views illustrating a holding means in successive operational positions for engaging, frictionally holding, and releasing a weft thread.

DESCRIPTION OF THE PREFERRED EMBODIMENTS

Referring first to the schematic illustrations of FIGS. 1 to 8, FIG. 1 shows that a weft thread 8 is inserted from the right into a warp shed of the fabric 7, passing through an eye 10' to a thread supply reel, not shown, whereupon after closing of the respective warp shed, a weft thread 11 is inserted into the opened warp shed through an eye 10, and supplied from another supply reel, not shown on the left side of the loom. Instead of supplying weft threads on both sides of the loom by supply reels, weft threads having a measured length corresponding to the width of the fabric and the warp sheds may be used.

FIGS. 2 to 7 show successive operational steps in accordance with the method of the invention. As shown in FIG. 2, the weft thread 8 supplied on the right side of the loom, and passing through an eye 10' and an opened clamping means 12', has been picked through a warp shed and is held by the trailing holding means A of shuttle 1, which will be described herein after in greater detail. Shuttle 1 is stopped in a shuttle box, not shown, in an end position in which the trailing holding means A is located closely adjacent the left edge of the fabric 7 and the open warp shed so that only a short thread end 8a projects from the warp shed.

In the position of FIG. 3, holding means A and B, are open. At this moment, the reed 2 performs its beating motion relative to the shuttle 1 in the shuttle box (not shown) and beats the inserted old weft thread 8 into the fell of the fabric, the open holding means A permitting a slight displacement of the weft thread end 8a. The holding means B is engaging a new weft thread 11, a portion of which extended between eye 10 and the closed clamping means 12.

After the new weft thread 11 is engaged, the holding means B is closed and the clamping means 12 is opened.

In the position of FIG. 4, shuttle 1 has been picked in the opposite direction, with holding means A leading, and holding means B trailing due to the fact that the shuttle is now picked in opposite direction, as indicated by the arrows in FIGS. 2 and 4. The now trailing holding means B pulls weft thread 11 through the eye 10, the leading end of weft thread 11 being released by the open clamping means 12. The weft thread end 8a has been bent over the selvage of the previously formed pick and drawn out of the now leading holding means A to form bent-over end 8b due to the tension direction change of the gripping means A created by the reversal of the motion of the shuttle moving back over the next thread now fixed in the fabric.

In the position of FIG. 5, the second pick, started in the position of FIG. 4, has been completed, and weft thread 11 has been inserted into the second warp shed together with weft thread end portion 8b. The leading end of the weft thread 11 was held during the pick by the trailing holding means B, and shuttle 1 is stopped in a position in which holding means B with the leading end 11a of weft thread 11 is located in the proximity of the right edge of fabric 7 and of the warp shed. The leading holding means A has been opened to receive a new weft thread 8', held between the displaced and closed clamping means 12' and eye 10', and was then closed to hold the new weft thread 8'.

In the position of FIG. 6, clamping means 12, which has been moved to a position adjacent the shed, as well as holding means A and B are open so that the reed 2 can beat the new weft 11 into the fell of the fabric and the holding means A engage a new weft thread 8' a portion of which extended between eye 10' and the closed clamping means 12'.

In the position of FIG. 7, the reed has moved to its rear position, and the next pick to the left of shuttle 1 has started. The clamping means 12 was closed, clamping the weft thread 11' extending from eye 10 to the shed. Holding means B leads again, and has just released the bent-over weft thread end 11b which was bent by holding means B into the new shed into which shuttle 1 was inserted. The trailing holding means A has engaged a new weft thread 8', and pulls the same through the open warp shed until shuttle 1 arrives again in the position of FIG. 2. The positions shown in FIGS. 2 and 5, 3 and 6, and 4 and 7, correspond to each other.

If measured length of weft threads are supplied on both sides of the loom, a straight weft thread end of proper length projects from the side of the warp shed remote from the side where the bent-over thread end is located, as shown at 8c in FIG. 7. If two weft threads are supplied by supply reels on both sides of the loom, cutting means C, provided on both sides of the fabric 7, as schematically indicated by the arrows C in FIGS. 4 and 7, cut the weft thread at its trailing end.

FIG. 8 illustrates bent-over weft thread ends 8b located in the same warp shed in which a weft thread 11 is located.

FIGS. 9 and 10 illustrate a shuttle 1 with holding means A and B in the positions shown in FIGS. 3 and 4, respectively. A reed 2 has reed rods 4 passing through the warp threads of the upper and lower warps for beating up an inserted weft 8. The reed is reciprocated in the direction of the double arrow 3 between two end positions shown in dashed and dot lines. Only one end member 5 is shown at the end of reed 2 to cooperate with the end portions 16b of an operating member 16 of holding means A for shifting the same between the open and closed position. A corresponding end member, not shown, is provided at the other side of reed 2, and cooperates with the end portion 16a of operating member 16 of holding means B when the shuttle 1 has been picked through a warp shed to the other side of the loom. An actuating arm 9 is connected with reed 2 by a shaft 100 for synchronous reciprocation, and is positioned to cooperate with end portion 16a of operating member 16 of holding means B when the shuttle is in the position of FIG. 9, stopped in a stationary shuttle box, not shown, on the left side of the loom and warp shed. In this position, end portion 16a of member 16 projects out of the shuttle box, not shown, and into the path of actuating arm 9 which moves with reed 2. As explained above, the holding means A is spaced a small distance from the edge of the fabric 7 when the shuttle 1 is in the position of FIG. 9. In this position, clamping means 12 and eye 10 hold the end of weft thread 11 in a position located in the open gap of holding means B. Actuating member 9 reciprocates in the direction of the double arrow 9' when the reed 2 reciprocates in the direction of the double arrow 3, with the reed comb 4 passing between the warp threads 6. Weft thread 11 is either pre-cut to the proper size, or is continuously supplied from a supply reel, not shown.

Clamping means 12 which holds the weft thread in opened and closed by a mechanism which is well known to those skilled in the art, and is moved in the direction of the double arrow 13, which is parallel to the movement of arm 9 indicated by arrow 9', but opposite to the same so that weft thread piece 11 between eye 10 and clamping means 12 is inserted into the open mouth formed by a pair of hook members 21, 22 and an arm of lever 18. Clamping means 12 is also moved between the position in which it is illustrated in FIGS. 2 and 5, and opened and closed in time relationship with this movement.

The holding means A and B are mounted in a cavity of the shuttle 1. As best seen in FIGS. 11 and 12, the holding means B, is mounted in the shuttle 1 by means of a pivot 15 which supports the operating member 16 for angular movement. Another pivot 17 supports one arm of an angular lever 18 in the shuttle. The parallel arms of the levers 16 and 18 are connected by a pair of hook members 21 and 22 by pivots 19 and 20, and the hook portions of members 21 and 22 are located on opposite sides of the other arm of angular lever 18. By operating the end portion 16a of operating member 16, mem-

bers 21, 22 and 18 are moved relative to each other between the open position projecting through a cutout 14 out of shuttle 1 as shown in FIG. 11, and the closed position shown in FIG. 12 retracted into the cavity of shuttle 1, and being substantially aligned. Arms 18, 21 and 22 serve as guide members for the weft thread. When guide members 21, 22 and 18 are in the open position spaced by an angular gap, as shown in FIGS. 9, 11 and 13, a weft thread can be placed in the gap, and when the guide members 18, 21, 22 are moved to the closed position shown in FIGS. 10, 12 and 14, the weft thread is bent alternately in opposite directions and passes over lateral face or edges on opposite sides of adjacent guide members 21, 18, 22 along a tortuous path. As best seen in FIG. 14, guide members 22, 18, 21 are spaced from each other a small distance equal to or greater than the thickness of the weft thread so that the weft thread is only frictionally held and not clamped.

As explained above, actuating members 9 and 5 effect opening of the holding means when the reed 2 performs a forward stroke, while during the rearward stroke of reed 2 with members 5 and 9, a spring 23 wound about pivot 15 and engaging member 16, urges the guide members 18, 21, 22 to the closed position, and retracts the entire holding means into the cavity of shuttle 1.

In the position of FIG. 14 and FIG. 4, the clamping means 12 is opened so that the pick can start. During the pick, the holding means 18, 21, 22 is closed and frictionally engages the weft thread 11 during the passage through the shed as schematically indicated by an arrow in FIG. 15. During the pick in the direction of the arrow in FIG. 15, the resistance of eye 10, and also the air friction acts on the trailing and free ends of weft thread 11 to hold the same wound about guide members 21, 18, 22, and in close frictional engagement with the same.

As shown in FIG. 8, the holding means A at the other end of shuttle 1 has inserted a weft thread 8 during the preceding pick into the shed formed by warp threads 6, and has been opened by the action of end member 5 of reed 2 on end portion 16b of operating lever 16, as also shown in FIG. 16.

Due to the beating of the weft thread by reed 2, 4, the free thread end projecting beyond the guide members of the holding means A is shortened.

When the shuttle 1 again enters the warp shed, as shown in FIG. 10 and FIG. 4, the free weft thread end changes its position due to inertia and air resistance, and the inserted weft thread end also changes its position in relation to the shuttle so that the weft thread is no longer bent over the guide members 21 and 22, but only over the guide member 18, as shown in FIG. 17. Due to the reduced friction, the free thread end 11b is no longer frictionally held, but slides out of the holding means and is bent over and inserted into the warp shed, as shown in FIG. 10, for forming a selvage.

It will be understood that each of the elements described above, or two more together, may also find a useful application in other types of methods and apparatuses for inserting a weft thread by a bobbin-less shuttle, differing from the types described above.

While the invention has been illustrated and described as embodied in a shuttle having friction holding means at both ends which are opened and closed by actuating means on both sides of the loom, it is not intended to be limited to the details shown, since various modifications and structural changes may be made without departing in any way from the spirit of the present invention.

What is claimed as new and desired to be protected by Letters Patent is set forth in the appended claims.

CLAIM:

1. Weft thread inserting method comprising the steps of picking a shuttle having holding means at either end, alternately in opposite directions through successive warpsheds to positions in which the respective trailing holding means is located adjacent the respective edge of the warp shed; opening the holding means at both ends of the shuttle supplying at either side of the warp shed after each pick a new weft thread to the holding means leading in the direction of the completed

pick; closing said leading holding means for holding the new weft thread; and closing the trailing holding means so that during the following pick in the opposite direction, when said trailing holding means becomes the leading holding means and said leading holding means becomes the trailing holding means, the old weft thread is pulled out of the closed holding means, and the new weft thread is inserted by the now trailing closed holding means into the next following warp shed.

2. The method of claim 1 wherein said trailing holding means is opened adjacent the warp shed so that the respective old weft thread is released and forms a thread end projecting from the edge of the closed warp shed.

3. The method of claim 1 comprising operating the holding means holding the old weft thread and leading at the beginning of a new pick so that the end of the old weft thread is inserted into the next following warp shed to form a selvage.

4. The method of claim 1 comprising beating of each new inserted weft thread by reciprocating reed means; and opening and closing said holding means in synchronism with the reed movement.

5. Weft inserting arrangement, comprising a shuttle having first and second holding means at the ends thereof, respectively, each holding means having a plurality of guide members including at least one pair of first guide members and at least one second guide member, and means mounting said first and second guide members for movement relative to each other in parallel planes between an open position in which said first guide members are spaced from said second guide member in said planes for forming with said second guide member a gap for receiving and releasing a straight weft thread, and a closed position in which said second guide member overlaps and is at least partly located between said first guide members, said mounting means including means for rigidly spacing in said closed position said second guide member from said first guide members in a direction normal to said parallel planes, distances at least equal to the thickness of the weft thread so that in said closed position the weft thread is alternately bent in opposite directions and deflected along a tortuous path by said first and second guide members while being frictionally engaged by faces of said first and second guide members whereby the weft thread is frictionally held by said guide members in said closed position; and actuating means for moving said guide members between said open and closed positions.

6. Weft inserting arrangement as claimed in claim 5 wherein said shuttle is formed with a cavity having openings; wherein said holding means are located in said cavity; wherein said guide members of holding means in said open position project out of said openings; and wherein said guide members of holding means in said closed position are withdrawn into said cavity.

7. Weft inserting arrangement as claimed in claim 5 wherein said actuating means move the holding means leading after completion of a pick in one direction between said closed and open positions for engaging a new weft thread, and move the respective trailing holding means from said closed position holding an inserted weft thread to said open position so that the end of the old weft thread can be pulled out of said trailing holding means.

8. Weft inserting arrangement as claimed in claim 5 wherein each holding means comprises means connecting said first and second guide members for relative angular movement between said open position and said closed position, said first and second guide members forming in said open position an angular gap, and having in said closed position on opposite sides staggered lateral faces bending the weft thread alternately in opposite directions.

9. Weft inserting arrangement, comprising a shuttle having first and second holding means at the ends thereof, respectively, each holding means having a plurality of guide members including at least one pair of first guide members and at least one second guide member, and means mounting said first and

second guide members for movement relative to each other in parallel planes between an open position in which said first guide members are spaced from said second guide member in said planes for forming with said second guide member a gap for receiving and releasing a straight weft thread, and a closed position in which said second guide member overlaps and is at least partly located between said first guide members rigidly spaced from the same in a direction normal to said parallel planes distances at least equal to the thickness of the weft thread so that in said closed position the weft thread is alternately bent in opposite directions and deflected along a tortuous path by said first and second guide members while being frictionally engaged by faces of said first and second guide members whereby the weft thread is frictionally held by said guide members in said closed position, each holding means comprising pivot means mounting said first and second guide members for angular scissor-like movement between said open and closed positions; and actuating means for moving said guide members between said open and close positions.

10. Weft inserting arrangement, comprising a shuttle having first and second holding means at the ends thereof, respectively, each holding means having a plurality of guide members including at least one pair of first guide members and at least one second guide member, and means mounting said first and

second guide members for movement relative to each other in parallel planes between an open position in which said first guide members are spaced from said second guide member in said planes for forming with said second guide member a gap for receiving and releasing a straight weft thread, and a closed position in which said second guide member overlaps and is at least partly located between said first guide members rigidly spaced from the same in a direction normal to said parallel planes distances at least equal to the thickness of the weft thread so that in said closed position the weft thread is alternately bent in opposite directions and deflected along a tortuous path by said first and second guide members while being frictionally engaged by faces of said first and second guide members whereby the weft thread is frictionally held by said guide members in said closed position, each holding means including operating means connected with at least one of said guide members; and actuating means for moving said guide members between said open and closed positions, said actuating means including reciprocating reed means having parts located on both sides of a warp shed, said operating means being actuated by said parts of said reciprocating reed means to move said guide members between said open and closed positions.

* * * * *

25

30

35

40

45

50

55

60

65

70

75