

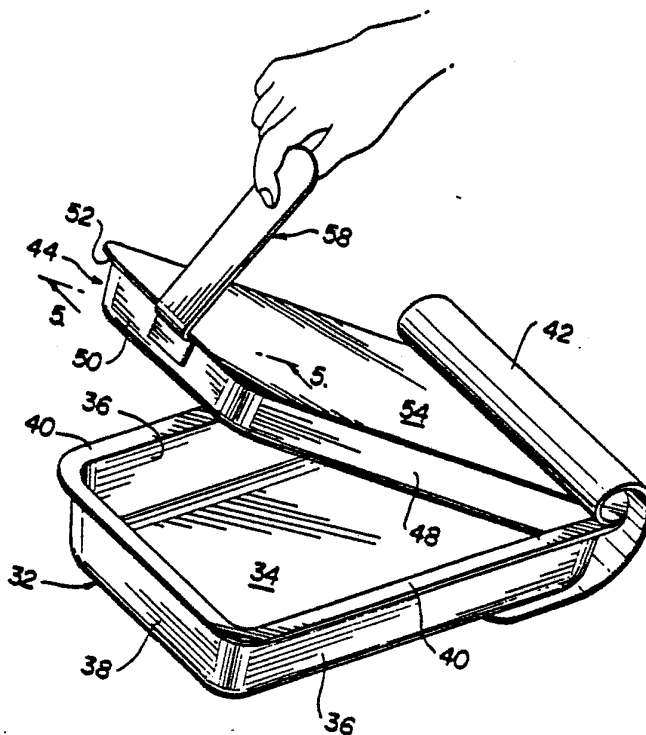

INTERNATIONAL APPLICATION PUBLISHED UNDER THE PATENT COOPERATION TREATY (PCT)

<p>(51) International Patent Classification⁴ : B65D 77/04, 81/18</p>	<p>A1</p>	<p>(11) International Publication Number: WO 87/ 05278 (43) International Publication Date: 11 September 1987 (11.09.87)</p>
<p>(21) International Application Number: PCT/US86/01904 (22) International Filing Date: 12 September 1986 (12.09.86) (31) Priority Application Number: 834,421 (32) Priority Date: 28 February 1986 (28.02.86) (33) Priority Country: US (71) Applicant: COOPERVISION, INC. [US/US]; 3145 Porter Drive, Palo Alto, CA 94304 (US). (72) Inventor: STEPPE, Dennis, L. ; 230 South Prospect Street, Tustin, CA 92680 (US). (74) Agents: BOLAND, Thomas, R. et al.; Vorys, Sater, Seymour and Pease, 1828 L Street, N.W., Suite 1111, Washington, DC 20036-5104 (US).</p>		<p>(81) Designated States: AT (European patent), AU, BE (European patent), BR, CH (European patent), DE (European patent), DK, FI, FR (European patent), GB (European patent), IT (European patent), JP, KR, LU (European patent), NL (European patent), NO, SE (European patent). Published <i>With international search report.</i></p>
<p>(54) Title: STERILE PACKAGE WITH LIFTING STRAP</p>		



(57) Abstract

A double sterile tray package (30) for storing articles in a sterilized condition and for enabling aseptic transfer of the inner tray (44) and articles contained therein into a sterile field includes a lifting strap (58) attached adjacent one side edge of the inner tray and having a free end disposed centrally of the top cover (54) of the inner tray in position to be exposed upon opening of the outer tray whereby the lifting strap may easily be grasped for lifting the inner tray without danger of contamination to the inner tray or to scrubbed personnel removing the inner tray.

FOR THE PURPOSES OF INFORMATION ONLY

Codes used to identify States party to the PCT on the front pages of pamphlets publishing international applications under the PCT.

AT	Austria	FR	France	ML	Mali
AU	Australia	GA	Gabon	MR	Mauritania
BB	Barbados	GB	United Kingdom	MW	Malawi
BE	Belgium	HU	Hungary	NL	Netherlands
BG	Bulgaria	IT	Italy	NO	Norway
BJ	Benin	JP	Japan	RO	Romania
BR	Brazil	KP	Democratic People's Republic of Korea	SD	Sudan
CF	Central African Republic	KR	Republic of Korea	SE	Sweden
CG	Congo	LI	Liechtenstein	SN	Senegal
CH	Switzerland	LK	Sri Lanka	SU	Soviet Union
CM	Cameroon	LU	Luxembourg	TD	Chad
DE	Germany, Federal Republic of	MC	Monaco	TG	Togo
DK	Denmark	MG	Madagascar	US	United States of America
FI	Finland				

- 1 -

STERILE PACKAGE WITH LIFTING STRAP

5 This invention relates to sterile packages for medical instruments, devices and supplies and more particularly to an improved double-sterile package which may be opened and the sterile contents removed without danger of contamination either of the contents or of personnel removing the contents in a sterile environment.

10 Medical instruments, devices and supplies (hereinafter, articles) which are used in surgical and other medical procedures are normally sterilized and stored in sterile packages. Such packages are conventionally prepared and sterilized in advance and therefore the packaging material must be sufficiently imper-
15 vious to bacteria to enable the articles to be stored for substantial periods. At the same time, the packages must be capable of being opened quickly and easily without the aid of special instruments or tools
20 and without risk of contamination of the contents or of the scrubbed personnel removing the contents in a sterile environment.

Packages of sterilized articles are conventionally stored in non-sterile environments and therefore the external surface of the packages are themselves considered contaminated. Once the outer package
25 wall is ruptured to expose the packaged article, care must be taken in removing the article to avoid contact with the ruptured edge of the package with the sterilized article or the article will be considered contaminated and unsafe for use. Similarly, when an article
30 is removed by sterilized personnel, extreme care must be exercised to avoid contact between the hands and the ruptured edge or outer surface of the package.

35 Double sterile tray designs are known which facilitate aseptic transfer of sterilized articles into

- 2 -

a sterile field. Such known double-tray designs conventionally employ a sealed, sterilized inner tray or package within a second sealed sterile outer tray. When the outer tray is opened, the sealed inner tray and its contents are transferred aseptically to the sterile field. This is done either by the person opening the outer tray flipping the sealed inner tray and its contents into the sterile field or by scrubbed personnel lifting the inner tray and its contents from the opened outer tray. In practice, the latter method is most commonly employed, particularly with larger and bulkier items. Also, flipping or dumping the inner tray and contents from the opened outer tray presents risk of damage to the tray and its contents and also presents greater risk of contamination to the sterile field.

In order to facilitate transferring the inner sterile package from an opened outer sterile tray, prior art double sterile tray designs have been formed with recesses or indentations in the periphery of the inner trays to provide "finger openings" or space for the scrubbed personnel to insert one or more fingers between the inner and outer trays to enable lifting of the inner tray. The location of these finger openings adjacent the peripheral wall of the outer tray still presents a problem, however, due to their proximity to the non-sterile opened edge portion of the outer tray and the risk of contamination to scrubbed personnel removing such sterile inner trays is high. While this risk could be reduced, but not entirely eliminated, by providing larger lifting openings in the periphery of the inner tray, this solution is not satisfactory both because an excessively large and therefore more expensive outer tray is required and because of the waste of valuable storage space.

- 3 -

It is a primary object of the present invention to provide an improved double sterile tray package which overcomes the disadvantages of the prior art double sterile tray packages discussed above.

5 Another object is to provide an improved double sterile tray package which facilitates removal of the inner tray from an opened outer tray without risk of contamination to the inner tray or to scrubbed personnel removing the inner tray.

10 Another object is to provide such a double sterile tray package which provides maximum storage space within the package.

 Another object is to provide such an improved double sterile tray package which is inexpensive to
15 manufacture and which is easy to use.

 In the attainment of the foregoing and other objects and advantages, an important feature of the present invention resides in providing improved lifting means on the inner tray of a double sterile tray
20 package. The lifting means is readily accessible, when the outer tray is opened, at a central location on the exposed top surface of the inner tray and is adapted to facilitate the lifting of one edge portion of the inner tray clear of the outer tray where it may readily be
25 grasped by scrubbed personnel for transfer to a sterile field. The lifting means preferably is in the form of an elongated flexible lifting strap having one end securely attached adjacent the side of the inner tray to be lifted, with the remaining portion of the strap
30 extending over and resting on the removable top cover of the inner tray in position to be readily accessible when the top cover of the outer tray is removed. Preferably, the lifting strap is made from a relatively thin material such as a high strength paper which will
35 lay flat on the top cover and remain in position during handling of the sealed double sterile tray package as during sterilization, storage and the like.

- 4 -

Other features and advantages of the invention will be apparent from the detailed description contained hereinbelow, taken in conjunction with the drawings, in which:

5 Figure 1 is a perspective view of a prior art double sterile tray package shown with the top cover of the outer tray removed and illustrating the inner tray being removed;

10 Figure 2 is a top plan view of a prior art double sterile tray package showing an alternate means for facilitating removal of the inner tray;

15 Figure 3 is a perspective view of a double sterile tray package according to the present invention and showing the top cover sheet of the outer tray partially removed to provide access to the inner tray;

 Figure 4 is a perspective view of the double sterile tray package of Figure 3 and showing the inner tray being removed;

20 Figure 5 is an enlarged fragmentary sectional view taken along line 5-5 of Figure 4; and

 Figure 6 is a perspective view of a lifting strap suitable for attachment to and lifting of the sealed inner tray of a double sterile tray package.

25 Referring now to the drawings in detail, prior art double sterile tray packages are illustrated in Figs. 1 and 2. Such packages, designated generally by the the reference numeral 10, conventionally employ a unitary, molded outer tray 12 having a bottom wall, not shown, and upwardly extending sidewalls 14 terminating in an out-turned flange 16 at the open top of the
30 tray. Trays 12 are illustrated as being generally rectangular in cross section, this configuration being the most commonly used configuration in the commercially available double sterile packages. A second or
35 inner tray, designated generally by the reference numeral 18, is nested within outer tray 12, with tray

- 5 -

18 being dimensioned to fit completely within tray
12. A cover sheet 20 extends over and closes inner
tray 18, with the cover sheet 20 being sealed to the
out-turned flange at the top of tray 18 by an adhesive
5 material which, while forming a bacteriologically
impervious seal, also permits the cover sheet 20 to be
peeled off in a manner known in the art. A similar
cover sheet, not shown, extends over and seals flange
16 on outer tray 12 when sterile articles are stored in
10 the double sterile tray package. Normally, either the
cover sheets 20 or the body of the trays will be formed
of a material which is to some extent gas permeable but
bacteriologically impermeable whereby articles packaged
and sealed in the double sterile tray package may be
15 sterilized in a known manner without rupturing the
peelable adhesive seal.

When an article packaged in a double sterile
tray package is desired in a sterile field, the sealed
package may be transported by non-sterile personnel to
20 a transfer area adjacent the sterile field. The outer
tray is then opened by peeling off the outer cover
sheet 20, taking care not to contact any portion of the
inner sealed tray. In the prior art package illus-
trated in Figures 1 and 2, one or more recesses, gen-
25 erally referred to as finger holes, are provided in the
top flange and sidewall portions of the inner tray. In
the embodiment shown in Fig. 1, two finger holes 22, 24
are provided one at each of two diagonally opposed
corners of the inner tray, to permit scrubbed personnel
30 to insert one or more fingers between the inner wall of
the open outer tray and the sealed inner tray to lift
the inner tray. However, as is readily seen from
Figure 1, this arrangement inherently requires the
scrubbed personnel removing the inner tray to manipu-
35 late one or both hands in close proximity to the conta-
minated peripheral edge of the open outer tray. Thus,

- 6 -

while the finger holes 22, 24 theoretically provide means for removal of the inner tray without contaminating either the inner tray or the scrubbed personnel removing it, extreme care must be exercised to avoid contamination and the resulting unnecessary delay and waste of material including sterile gloves and sometimes even the contents of the inner sterile tray. Also, it should be apparent that the relief portions or finger holes 22, 24 must extend into the enclosure of the inner tray since it is necessary to provide a continuous flange for sealing and maintaining the sterile atmosphere inside the package. This, of course, necessarily reduces the space available within the inner tray for packaging of articles.

In the prior art double sterile tray shown in Figure 2, the finger holes, 26, 28 for lifting the inner tray are formed centrally in opposed sidewall portions of the inner tray. This arrangement may provide easier tilting and lifting of the inner tray, but the location of the openings in the central portion of the sidewalls can provide greater interference with articles to be packaged.

Referring now to Figures 3 - 6, a double sterile tray package 30 according to the present invention will be described. Package 30 comprises an outer tray 32 having a bottom wall 34 and integrally formed upwardly extending sidewalls 36 and end walls 38, with the side and end walls terminating at the open top of the tray in an out-turned flange 40. A peelable cover sheet 42 normally extends over the open top of tray 32 and is adhered to the upwardly directed surface of flange 40 to provide the sealed sterile closure for the package. Tray 32 may be substantially identical to tray 12 described above with respect to the prior art double sterile tray packages.

- 7 -

Package 30 also includes an inner tray 44, also preferably integrally formed from a single sheet of material to include a bottom wall 46, upwardly extending sidewalls 48 and end walls 50 and an out-turned top flange 52. A second peelable cover sheet 54 extends over the open top of tray 44 and is adhered to the upwardly directed surface of flange 52 to seal the package. Tray 44 preferably has a shape substantially identical to but slightly less than outer tray 32 so that the sealed inner tray will fit closely within the outer tray.

In accordance with the present invention, aseptic removal of the inner tray 44 from the opened outer tray 32 is facilitated by an elongated lifting strap 58 provided on the inner tray. Strap 58 preferably has one end portion 60 secured, as by a suitable adhesive, not shown, to the outer surface of one upwardly directed wall, for example, an end wall 50 of the inner tray and to the downwardly directed surface of the out-turned flange 52. The other end portion 64 of strap 58 extends around the edge of flange 52 and lies flat on the outer top surface of cover 54. The strap 58 is preferably of a length to terminate at a point near the center of cover sheet 54.

Lifting strap 58 is formed from a suitable material such as a high strength paper (including spun-bonded polyolefin fiber webs, such as those sold by E. I. duPont de Nemours & Co. under the name Tyvek®), fabric or sheet plastic which is sufficiently flexible to be manipulated with the hand without tearing, but which has sufficient stability to normally lie flat and stay in the desired location at the central portion of the inner package top cover during normal handling of the sealed package 30.

Lifting strap 58 is preferably formed separately and attached to the inner tray at the time of

- 8 -

packaging the article to be sterilized. To this end, the attachment end portion 60 of strap 58 may have a suitable adhesive material applied to one surface, with the adhesive coating protected by a suitable peelable cover sheet (not shown) in a manner well known. A score-line 62 is preferably formed between the adhesively coated attachment portion 60 and the lifting portion 64 so that, when the lifting strap is adhered to the inner package, the score-line will assure that the lifting handle portion 64 lies flat along the top surface of cover sheet 54.

In use of the double sterile package of the present invention, the adhesively coated portion 60 of lifting strap 58 is secured to the sealed inner tray on the side which is to be first removed from the outer tray by the scrubbed personnel. Strap 58 is attached so that score-line 62 coincides with the edge of the inner tray flange, thereby allowing the lifting portion 64 to lie flat on the top of the inner tray before the inner tray is inserted into the outer tray and sealed by cover sheet 42. By using a lifting strap material of sufficient dimensional stability, the lifting strap will stay in this position during subsequent handling such as in sterilization, shipping, storage and the like.

When the top cover 42 of outer tray 32 is removed by non-sterile personnel, the inner tray is presented to the scrubbed personnel for aseptic transfer. Lifting portion 64 of strap 58 is conveniently located in the center of the sterile field at the point furthest from the non-sterile sealed perimeter of the outer tray and can be easily grasped without danger of contamination to the scrubbed personnel. By pulling upward on the strap by one hand as illustrated in Figure 4, the side of the inner tray to which the strap is attached is lifted clear of the

- 9 -

outer tray and is readily accessible for removal by the other hand. Thus, the present invention provides an extremely simple yet reliable means for removal of the inner tray in a double sterile tray package without
5 danger of contamination to scrubbed personnel. Further, the lifting means does not in any way interfere with other packaging features and requires no additional packaging space. The lifting strap is easy to apply and is inexpensive to use.

10 It should be apparent that various modifications to the double sterile tray package could be made. For example, the lifting strap could be integrally formed with the peelable cover sheet on the inner tray 54.

15 Also, while the package is described with respect to double trays, it is believed apparent that other package configurations might be employed such as a single outer tray with an unwrapped inner package having the lifting strap centrally located. Accord-
20 ingly, while a preferred embodiment of the invention has been disclosed and described, it is believed apparent that the invention is not so limited and it is therefore intended to include all embodiments which come within the spirit and scope of the invention.

- 10 -

1 WHAT IS CLAIMED:

2

3 1. A double sterile tray package for storing
4 articles in a sterilized condition and for enabling
5 aseptic transfer of the inner tray and articles con-
6 tained therein into a sterilized field, the package
7 comprising

8 an outer tray having a bottom wall and up-
9 wardly extending sidewalls terminating in an open top,
10 an inner tray received within said outer tray
11 and having a bottom wall and upwardly extending side-
12 walls terminating in top edge portions defining an open
13 top,

14 a first removable cover sheet extending over
15 and sealing said open top of said inner tray,

16 a second removable cover sheet extending over
17 and sealing said open top of said outer tray when the
18 sealed inner tray is positioned therein, the second
19 removable cover sheet extending in generally contiguous
20 overlying relation to said first cover sheet, and

21 elongated lifting strap means having one end
22 portion secured to said inner tray and a free end
23 portion extending in overlying relation to said first
24 removable cover sheet and terminating at a point spaced
25 inwardly from said top edge portions of the sidewalls
26 of said inner tray, whereby said free end portion of
27 said lifting strap is exposed by removal of said second
28 cover sheet from said outer tray to enable the lifting
29 strap to be grasped by scrubbed personnel to lift said
30 inner tray to a position to be grasped by the hand to
31 aseptically remove the sealed inner tray and contents
32 from the opened outer tray.

33

34 2. The double sterile tray package defined in
35 claim 1 wherein said lifting strap comprises a length
36 of a flexible material having one end secured to the

- 11 -

1 outer sidewall surface of said inner tray, said free
2 end portion extending around the peripheral edge of
3 said flange defining the open top of said inner tray,
4 and lying in contact with the outer surface of said
5 first cover sheet.

6
7 3. The double sterile tray package defined in
8 claim 2 wherein said strap further comprises a score-
9 line extending transversely of said length of flexible
10 material, said score-line being disposed along the top
11 edge portion of said sidewall defining the open top of
12 the inner tray whereby the free end portion of said
13 strap may be folded to lie in said contacting relation
14 with the outer surface of said first cover sheet.

15
16 4. The double sterile tray package defined in
17 claim 3 wherein said strap is adhesively bonded to the
18 outer surface of said inner tray sidewall.

19
20 5. The double sterile tray package defined in
21 claim 1 wherein said sidewalls of said inner tray
22 terminate in an out-turned flange extending around the
23 open top periphery of said inner tray, and wherein said
24 one end of said lifting strap is secured to said inner
25 tray adjacent said flange.

26
27 6. The double sterile tray package defined in
28 claim 5 wherein said lifting strap comprises a length
29 of flexible material having one end adhesively bonded
30 to an outer surface of one sidewall portion of said
31 inner tray, said strap extending around said flange and
32 lying on said first cover sheet.

33
34 7. The double sterile tray package defined in
35 claim 6 wherein said strap further comprises a score-
36 line extending transversely of said length of flexible

- 12 -

1 material, said score-line being disposed adjacent the
2 outer peripheral edge of said flange.

3

4 8. The double-sterile tray package defined in
5 Claim 1 wherein said free portion of said lifting strap
6 is located so that a lifting portion of said strap is
7 located at the greatest possible distance from said
8 sidewalls of said outer tray after said second cover
9 sheet has been removed.

10

11 9. A double sterile tray package comprising a
12 sealed inner tray for containing articles to be
13 packaged, a sealed outer tray containing said inner
14 tray, said outer tray including a removable top cover
15 sheet, and an elongated flexible lifting strap having
16 one end portion secured to said inner tray and a free
17 portion disposed in position to be exposed upon removal
18 of said top cover sheet to thereby facilitate lifting
19 and aseptically removing said inner tray from said
20 outer tray.

FIG. 1
PRIOR ART

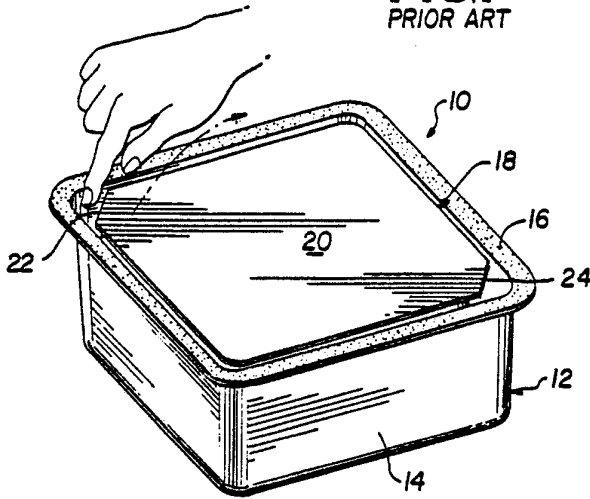

FIG. 2
PRIOR ART

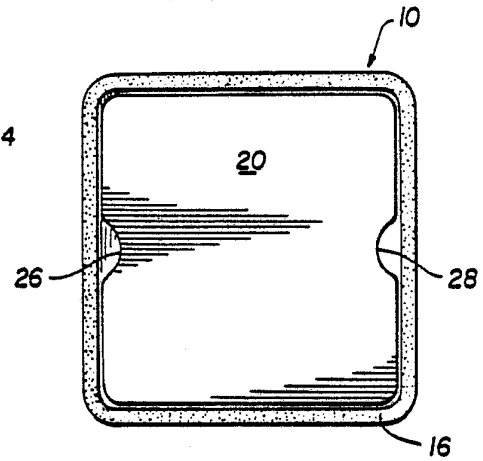

FIG. 3

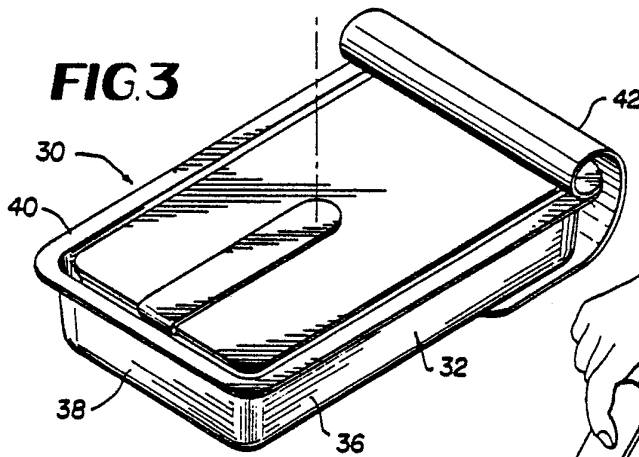

FIG. 5

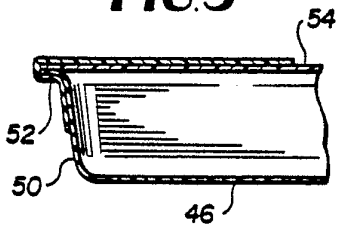

FIG. 4

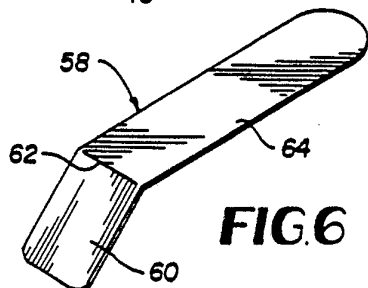
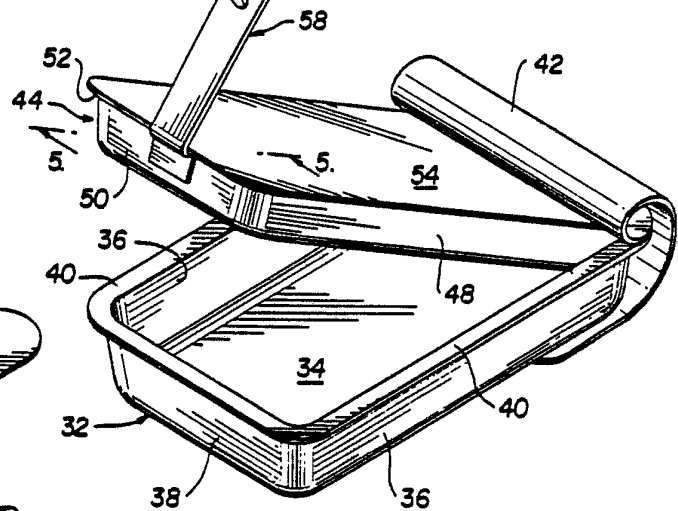

FIG. 6

INTERNATIONAL SEARCH REPORT

PCT/US86/01904

International Application No

I. CLASSIFICATION OF SUBJECT MATTER (if several classification symbols apply, indicate all) ³		
According to International Patent Classification (IPC) or to both National Classification and IPC		
IPC 4: B65D 77/04, 81/18 U.S. CL. 220/409; 206/363, 570		
II. FIELDS SEARCHED		
Minimum Documentation Searched ⁴		
Classification System	Classification Symbols	
U.S.	220/405,409; 206/363,438,439,570,571,572,804,828	
Documentation Searched other than Minimum Documentation to the Extent that such Documents are Included in the Fields Searched ⁵		
III. DOCUMENTS CONSIDERED TO BE RELEVANT ¹⁴		
Category [*]	Citation of Document, ¹⁶ with indication, where appropriate, of the relevant passages ¹⁷	Relevant to Claim No. ¹⁸
Y	Prior art disclosed in Figures 1 and 2 of this application. See page 4, line 24-page 6, line 22 of the specifications.	1-9
Y	US, A, 3,399,762, Published 03 September 1968 (Potter) See column 2, line 62-column 3, line 12	1-9
A	US, A, 3,613,879, Published 19 October 1971 (Kemble)	
A	US, A, 3,797,652, Published 19 March 1974 (Chesky)	
A	US, A, 4,197,947, Published 15 April 1980 (Zaidi)	
A	US, A, 4,423,732, Published 03 January 1984 (Tarjan et al)	
A	US, A, 4,444,310, Published 24 April 1984 (Odell)	
(See Second Sheet)		
<p>[*] Special categories of cited documents: ¹⁵</p> <p>"A" document defining the general state of the art which is not considered to be of particular relevance</p> <p>"E" earlier document but published on or after the international filing date</p> <p>"L" document which may throw doubts on priority claim(s) or which is cited to establish the publication date of another citation or other special reason (as specified)</p> <p>"O" document referring to an oral disclosure, use, exhibition or other means</p> <p>"P" document published prior to the international filing date but later than the priority date claimed</p>		<p>"T" later document published after the international filing date or priority date and not in conflict with the application but cited to understand the principle or theory underlying the invention</p> <p>"X" document of particular relevance; the claimed invention cannot be considered novel or cannot be considered to involve an inventive step</p> <p>"Y" document of particular relevance; the claimed invention cannot be considered to involve an inventive step when the document is combined with one or more other such documents, such combination being obvious to a person skilled in the art.</p> <p>"&" document member of the same patent family</p>
IV. CERTIFICATION		
Date of the Actual Completion of the International Search ¹		Date of Mailing of this International Search Report ²
30 October 1986		13 NOV 1986
International Searching Authority ¹		Signature of Authorized Officer ¹⁰
ISA/US		Stephen Garbe <i>Stephen Garbe</i>

FURTHER INFORMATION CONTINUED FROM THE SECOND SHEET

- | | |
|---|---|
| A | US, A, 4,464,552, Published 07 August 1984
(Pawlowski) |
| A | US, A, 4,497,406, Published 05 February 1985
(Takanashi) |

V. OBSERVATIONS WHERE CERTAIN CLAIMS WERE FOUND UNSEARCHABLE ¹⁰

This international search report has not been established in respect of certain claims under Article 17(2) (a) for the following reasons:

1. Claim numbers because they relate to subject matter ¹² not required to be searched by this Authority, namely:

2. Claim numbers because they relate to parts of the international application that do not comply with the prescribed requirements to such an extent that no meaningful international search can be carried out ¹³, specifically:

VI. OBSERVATIONS WHERE UNITY OF INVENTION IS LACKING ¹¹

This International Searching Authority found multiple inventions in this international application as follows:

1. As all required additional search fees were timely paid by the applicant, this international search report covers all searchable claims of the international application.
2. As only some of the required additional search fees were timely paid by the applicant, this international search report covers only those claims of the international application for which fees were paid, specifically claims:
3. No required additional search fees were timely paid by the applicant. Consequently, this international search report is restricted to the invention first mentioned in the claims; it is covered by claim numbers:
4. As all searchable claims could be searched without effort justifying an additional fee, the International Searching Authority did not invite payment of any additional fee.

Remark on Protest

- The additional search fees were accompanied by applicant's protest.
- No protest accompanied the payment of additional search fees.