

F. K. HENDRICKSON.  
 GEARING FOR LATHES.  
 APPLICATION FILED DEC. 21, 1907.

984,370.

Patented Feb. 14, 1911.

3 SHEETS—SHEET 1.

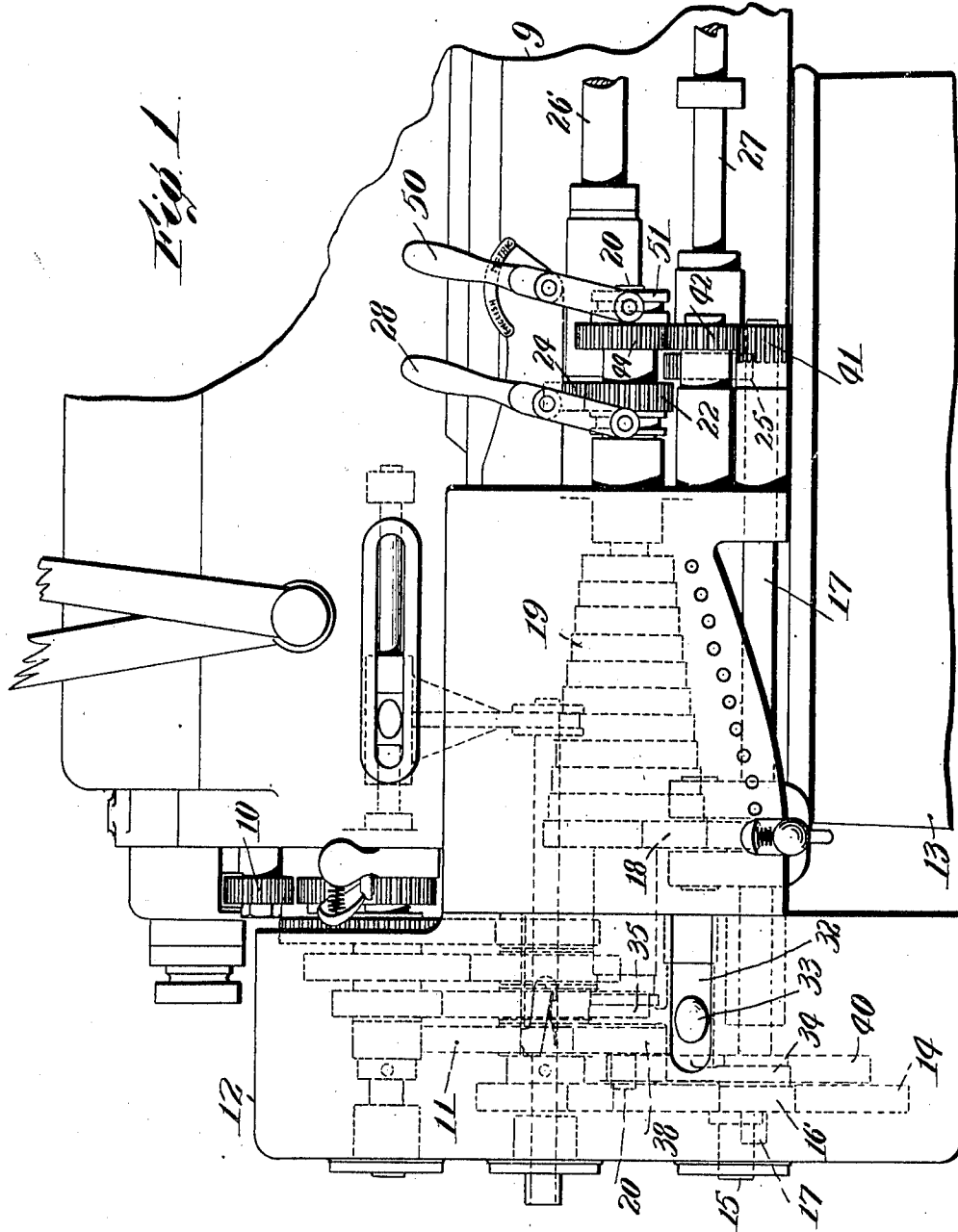

Witnesses:

C. F. Mason  
 W. C. Regan

Inventor:

F. K. Hendrickson  
 By Attorneys  
 Southgate & Southgate

F. K. HENDRICKSON.  
 GEARING FOR LATHES.  
 APPLICATION FILED DEC. 21, 1907.

984,370.

Patented Feb. 14, 1911.

3 SHEETS—SHEET 2.

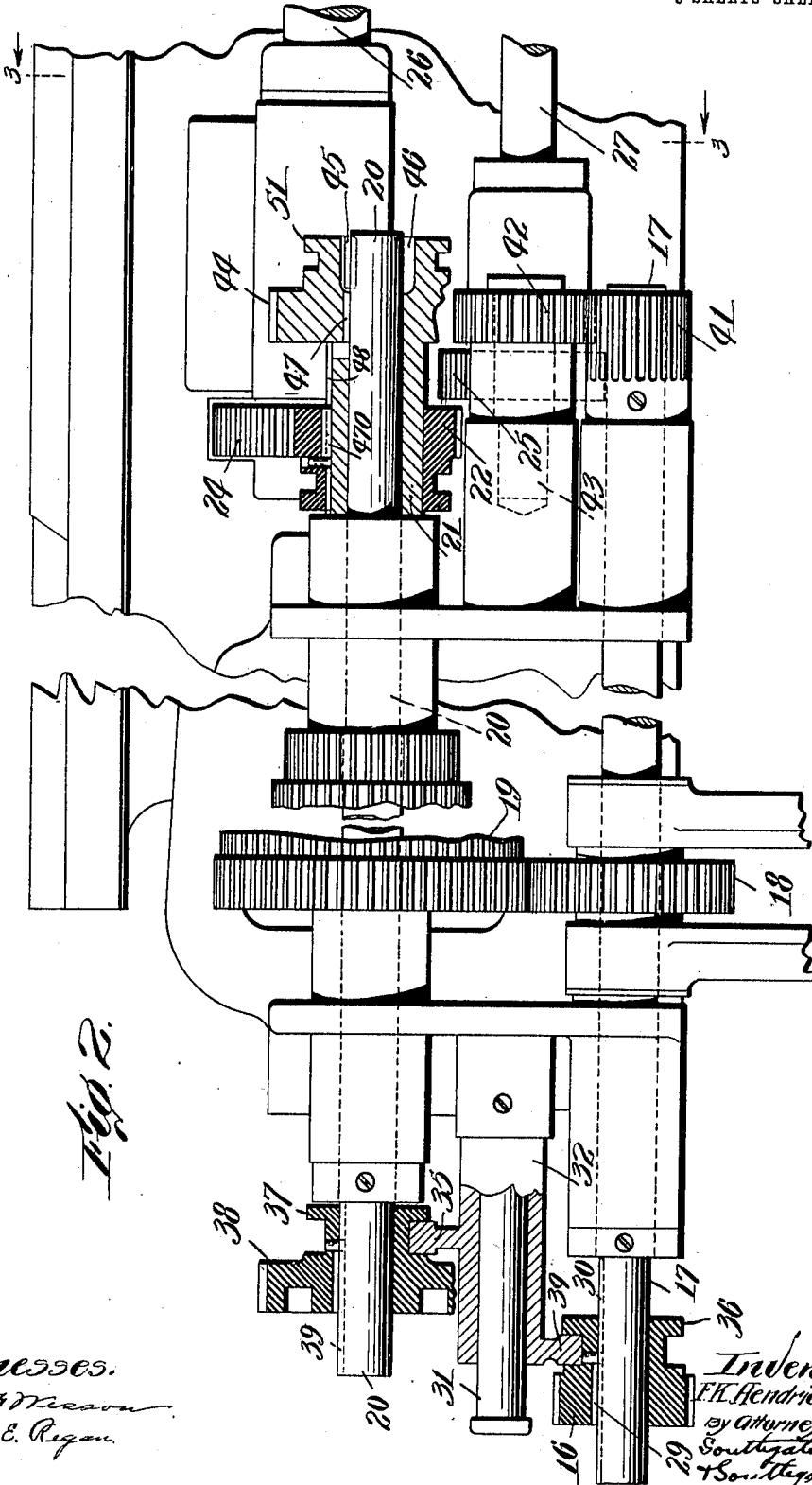

*Fig. 2.*

*Witnesses.*  
*C. F. Mason*  
*W. E. Regan*

*Inventor*  
*F. K. Hendrickson*  
*By Attorneys*  
*Southgate*  
*& Son, Chicago.*

F. K. HENDRICKSON.  
 GEARING FOR LATHES.  
 APPLICATION FILED DEC. 21, 1907.

984,370.

Patented Feb. 14, 1911.

3 SHEETS—SHEET 3.

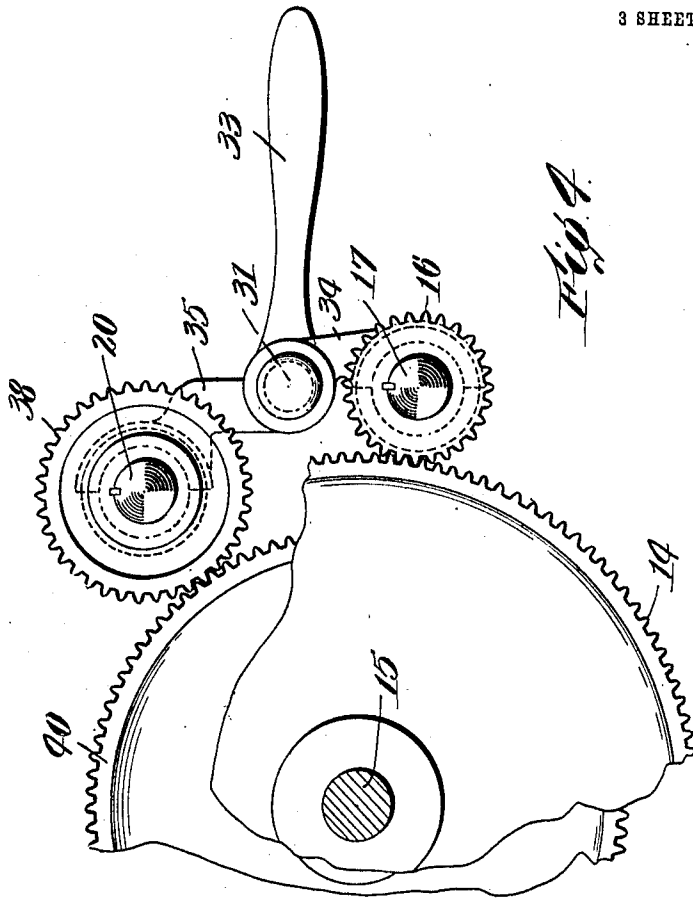

*Fig. 4.*

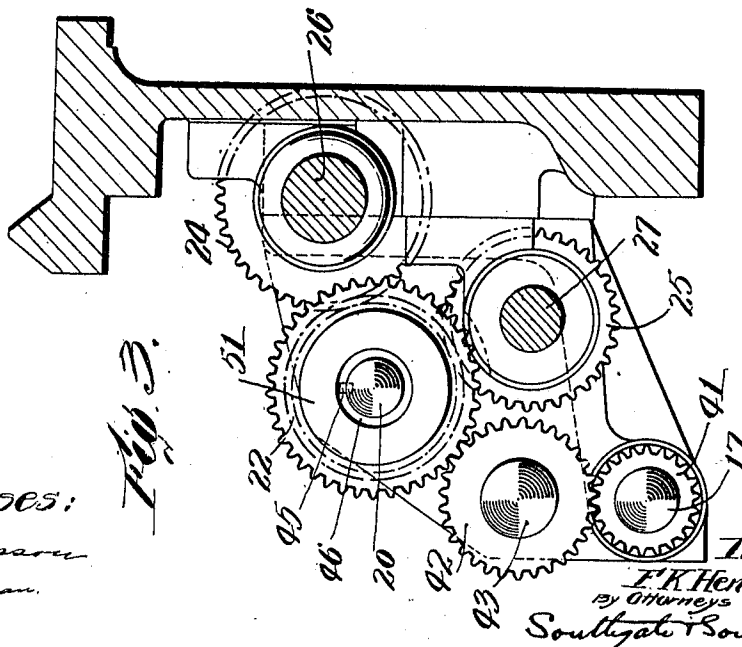

*Fig. 3.*

Witnesses:

*C. F. Mason*  
*M. C. Regan*

Inventor:  
*F. K. Hendrickson*  
 by Attorneys  
*Southgate & Southgate*

# UNITED STATES PATENT OFFICE.

FRED K. HENDRICKSON, OF WORCESTER, MASSACHUSETTS, ASSIGNOR TO PRENTICE BROS. COMPANY, OF WORCESTER, MASSACHUSETTS, A CORPORATION OF MASSACHUSETTS.

GEARING FOR LATHES.

984,370.

Specification of Letters Patent. Patented Feb. 14, 1911.

Application filed December 21, 1907. Serial No. 407,524.

*To all whom it may concern:*

Be it known that I, FRED K. HENDRICKSON, a citizen of the United States, residing at Worcester, in the county of Worcester and State of Massachusetts, have invented a new and useful Gearing for Lathes, of which the following is a specification.

This invention relates to a screw cutting lathe adapted to cut threads both by the English and by the metric system. It has heretofore been proposed to cut metric threads on an ordinary lathe by making rather elaborate changes in the gearing; that is, taking off several gears and substituting other gears for them.

The principal objects of this invention are to provide a construction especially adapted for the above mentioned purpose, in which the ordinary method of cutting threads according to the English system will not be modified in any material way, and yet in order to change the lathe over so as to cut threads by the metric system the only thing necessary to do will be to change certain gears by shifting levers connected with them so that it will be entirely unnecessary to remove any gears and replace them by others, and the parts will be left in such condition that they can be changed back for English thread-cutting in an equally simple manner and that the rod may be driven in either case without making any change except the usual one. This is accomplished according to the present invention in a very simple manner without adding greatly to the number of parts of the machine, and by means of connections by which instead of driving the lead screw or feed rod directly through the shaft on which the speed change-gear bank is mounted as for cutting English threads, the screw or rod is driven in the opposite way to cut metric threads. That is, power is transmitted to the bank of gears, and from that indirectly through the shaft on which is the pinion to be connected with said bank of gears, then back to a gear which in this case preferably rotates loosely on the gear bank shaft, and from it to the lead screw or feed rod. In this way the necessary ratios are secured for the metric system by the employment of mechanism ordinarily used for the English system.

Further objects and advantages of the invention will appear hereinafter.

Reference is to be had to the accompany-

ing drawings which show a preferred form of the invention, and in which—

Figure 1 is a side elevation of the head-end of a screw cutting lathe embodying this invention. Fig. 2 is an elevation showing a portion of the same with parts broken away showing interior construction. Fig. 3 is a sectional view on the line 3—3 of Fig. 2, and Fig. 4 is a fragmentary end elevation.

The invention is shown as applied to a high speed lathe of a type in which power is transmitted from the spindle (not shown) through gearing to power transmitting devices 11, preferably comprising a speed change mechanism, the details of which are not herein described, as they constitute no part of this invention, and as they may be of any known or desired type. The speed change mechanism is shown as mounted in a speed box 12 secured to the frame 13 of the machine. The power is transmitted from it to a gear 14 mounted to turn freely on a stud 15. For cutting English threads in the ordinary way, this gear meshes with a gear or pinion 16 mounted on the ordinary sliding yoke shaft 17 so as to turn the same. This shaft is connected with a gear 18 adapted to transmit power in a well known way to any desired one of the bank of gears 19 on a gear bank shaft 20, which carries a hub 21 which may be caused to rotate with the shaft 20, as will be described, and which is provided with a keyed sliding gear 22 adapted to mesh with either of two gears 24 and 25 on the lead screw 26 and feed rod 27 respectively. The gear 22 is moved back and forth by a lever 28 so as to cause the shaft 20 to drive the lead screw when in one position and the feed rod when in the other. The parts so far described are substantially the same as those ordinarily employed on lathes of this type for cutting English screw-threads, and they are shown herein in order to illustrate how this invention may be applied to one type of lathe.

According to this invention, the lathe is provided with means whereby it may be changed over from the English system to the metric system without removing or replacing any gears or their connections. In order to accomplish this, an ordinary lathe adapted for cutting English threads, as for example the one above described, is provided with certain additional features as will now be described. In the first place, I have

found that in order to secure the proper ratios and use the bank of gears 19 without modification, the shaft 20 may be driven directly from the speed change mechanism 11 instead of through the shaft 17, and that this may be done in such a way as to bring the proper ratios between the gears for cutting threads by the metric system. In order to do this means is provided for throwing the gear 14 out of mesh with the gear 16 and simultaneously connecting the shaft 20 with the speed change mechanism 11 through certain gearing, which will be described hereinafter, and in addition to that, means is provided whereby the hub 21 may be disconnected from the shaft 20 so that it will rotate thereon but independently thereof, being driven directly from the shaft 17 which of course in turn in this case is driven from the bank of gears on the shaft 20. In other words, in order to cut threads by the metric system on a lathe of this type, the shaft 20 is driven from the spindle the shaft 17 is disconnected therefrom and driven from the shaft 20 through the bank of gears, the hub 21 is disconnected from the shaft 20 so as to rotate freely and is driven from the shaft 17. In this way by proper ratios between the several gears for driving the shaft 20, the necessary speeds can be imparted to the lead screw 26. The way in which this is done in accordance with the form of the invention shown in the drawings is as follows:—The gear 16 is provided with a key 29 sliding in an elongated keyway 30 on the shaft 17 so that the gear may be moved longitudinally of the shaft into and out of mesh with the gear 14. A stud 31 is mounted on the speed-box or frame of the lathe and provided with a sliding hub 32 adapted to be reciprocated by a handle 33. This hub has a pair of yokes or the like 34 and 35, one engaging a collar 36 on the gear 16 and the other engaging a collar 37 on a gear 38 which is provided with a key in an elongated keyway 39 on the shaft 20, so that the reciprocation of the handle 33 will cause the two gears 16 and 38 to move along their respective shafts in the same direction. When these gears are moved along in this way so as to bring the gear 16 out of mesh with the gear 14, this disconnects the shaft 17 from the source of power and brings the gear 38 into mesh with the gear 40 which is fixed with respect to the gear 14 and turns therewith. It will be seen that now power is transmitted through the change speed mechanism 11, the gear 14, and gear 40, directly to the shaft 20. Power will then be transmitted through the bank of gears 19 to the pinion 18 and shaft 17, which is provided with a gear 41 preferably located on the opposite end thereof and meshing with a gear 42 on a stud 43. This gear 42 is adapted to mesh with a gear 44 on the hub 21 when the

latter is in the position shown in Fig. 2. In this position it will be observed that the hub 21 is so located that a key 45 on the end of the shaft 20 turns freely in a recessed or counter-sunk opening 46 in the gear 44. When, however, the hub is moved to the right in Fig. 2, the key 45 enters the keyway 47 in the hub 21, so that the hub will turn with the shaft 20. In the present case, however, when metric threads are being cut the hub is rotatable independently of the shaft, but the power is transmitted to the lead screw and feed rod by the other gear 22 on the hub in the manner which has been described. The gear 22 is shiftable independently of the hub, but is always keyed to it by the key 470 which slides in an elongated keyway 48 on the hub. Now it will be seen that the power is transmitted to the lead screw or feed rod in a different manner, namely, from the gear 14 directly to the gear 40, and through the gear 38, shaft 20, bank of gears 19, gear 18, shaft 17, gears 41, 42, 44, hub 21, and then through the gear 22 in the ordinary way. On account of this operation the necessary changes of speed occurring back of the gear 14 are secured in the usual way, while the changes of speed between this gear and the hub 21 are secured by the bank of gears 19, but in the reverse order in the two systems. The changes, however are secured by manipulating the pinion 18 as usual. I find that the necessary changes to cut the standard threads according to the two systems are of such a nature that the desired result can be accomplished in this way. For example, if a 4-pitch lead screw is used, as is common practice in lathes for cutting English screw threads, the gears 14 and 40 must have a certain ratio, as for example, 127 to 100 for cutting the standard metric threads with the ordinary bank of gears which is usually used for a 4-pitch lead screw, the other gearing being the same as is the standard for this type of lathe. Of course, the ratio of 100 to 127 is one which while necessary in a lathe having gearing proportions in the manner shown in these drawings, yet will be varied in accordance with the requirements if the machine is constructed with other gearing.

It is to be observed that the lever 28 is operated in the usual way independently of whether the lathe is adjusted for cutting English or metric threads, and that all the other operating arrangements may be the same as for any standard lathe. In order to change the lathe over from English to metric, it is only necessary to shift the handle 33 and to swing a lever 50 which is connected with a collar 51 to slide the gear 44 and hub 21 back and forth so as to bring the keyway 47 thereof into and out of engagement with the key 45. It is also to be observed that the shifting of either one of

these handles or levers 33 or 50 without moving the other cannot possibly result in any damage to the machine, because if the handle 33 is shifted to the position for cutting metric threads, the gear 38 will be in mesh with the gear 40 so as to turn the shaft 20, while, if the handle 50 is shifted to the English position, the key 45 will be in engagement with the keyway 47, and the rotation of the shaft 17 from the shaft 20 will simply rotate the gears 41 and 42, but will not transmit that rotation to the gear 44 because it is out of engagement with the gear 42. On the other hand, if the handle 33 is in the English position and the lever 50 in the metric position, power will be transmitted to turn the shaft 17 and the shaft 20 therethrough, but the shaft 20 will not turn the hub 21 because its key is out of engagement with the keyway, but the gear 42 which is turned by the shaft 17 will operate the hub at a single speed independently of the position of the sliding yoke gear 18.

While I have illustrated and described a preferred form of the invention, I am aware that many modifications may be made therein by persons skilled in the art without departing from the scope of the invention as expressed in the claims. Therefore, I do not wish to be limited to the particular type of machine, nor to the details of construction shown, but

What I do claim is:—

1. In a lathe, the combination of a lead screw, a shaft, a bank of gears thereon, a second shaft, a gear connected with said second shaft and adapted to mesh with said bank of gears, a second gear on the second shaft, means for transmitting power to said second gear, means connected with the first shaft for transmitting power to the lead screw, means for disconnecting the first named means for driving the second gear, and means cooperating with part of said first named means for transmitting power to the first named shaft independently of the second shaft.

2. In a lathe, the combination of a lead screw, a shaft, a second shaft, means operatively connecting the second shaft with the first shaft, a speed change mechanism, means for transmitting power to said shaft from the speed change mechanism, means connected with the first shaft for transmitting power to the lead screw, means for disconnecting the speed change mechanism from the second shaft, and means cooperating with part of the first named means for transmitting power to the first named shaft independently of the second shaft.

3. In a lathe, the combination of a gear bank shaft, a sliding yoke shaft, means for transmitting power to said sliding yoke shaft independently of the gear bank shaft, means for rendering said means inoperative

to transmit power to the sliding yoke shaft, means cooperating with part of the first named means for transmitting power to the gear bank shaft, a hub on the gear bank shaft, a gear on the hub, means for disconnecting the gear on the hub from the gear bank shaft, and means on the sliding yoke shaft for transmitting power to the gear on the hub when it is so disconnected.

4. In a lathe, the combination of a gear bank shaft, a sliding yoke shaft connected with the gear bank shaft, means for transmitting power to said sliding yoke shaft, means for disconnecting the sliding yoke shaft from part of the power transmitting means, and for connecting said power transmitting means to the gear bank shaft, a hub adapted to slide on the gear bank shaft and having a key-way, a key on the gear bank shaft adapted to engage the key-way in one position of the hub, and means operated by the sliding yoke shaft for transmitting power to said hub to turn it when said hub is in position in which the key does not engage the key-way.

5. In a lathe, the combination of a feed rod, a lead screw, a gear bank shaft, a sliding yoke shaft connected therewith, a gear thereon, a gear for transmitting power to the gear on said sliding yoke shaft, means for disconnecting the last named gear from the gear or the sliding yoke shaft, means for transmitting power to the gear bank shaft, a hub slidable on the gear bank shaft and adapted to be connected to rotate with it in one position thereof and to rotate independently of it in another, a gear slidably mounted on said hub adapted to transmit power to the lead screw in one position and to the feed rod in another, and means connected with the sliding yoke shaft for rotating the hub when it is free to rotate independently on the gear bank shaft.

6. In a lathe, the combination of a shaft, a second shaft connected with said first shaft, a gear thereon, a gear for transmitting power to said gear on the second shaft, means for disconnecting said gears, means for transmitting power to the first named shaft, a hub movable to two positions on the first shaft in one of which it rotates with said shaft and in the other independently of it, a gear on said hub, and means connected with the second shaft for engaging and rotating said gear when in position to rotate independently of the first shaft.

7. In a lathe, the combination of a shaft, a bank of gears thereon, a second shaft, a gear connected with said second shaft and adapted to mesh with said bank of gears, means for transmitting power to said second shaft, means for disconnecting said power transmitting means, means for transmitting power to the first named shaft, a hub movable to two positions, in one of

which it rotates with said shaft and in the other independently of it, a gear on said hub, and means connected with the second shaft for engaging and rotating said gear when in position to rotate independently of the first shaft, said means comprising a gear fixed to the second shaft, and a gear connecting it with said hub.

8. In a lathe, the combination of a shaft, a bank of gears thereon, a second shaft, a sliding yoke gear connected with said second shaft and adapted to mesh with said bank of gears, means for transmitting power to said second shaft, means for disconnecting said means, means for transmitting power to the first named shaft, a hub movable to two positions on the first shaft in one of which it is rotatable with it and the other independently of it, and a gear connected with the second shaft for meshing with said gear on the hub when in position to rotate independently of the first shaft and out of mesh with it when the hub is in position to rotate with the first shaft.

9. In a lathe, the combination of a shaft, a lead screw, a feed rod, a second shaft, means for connecting said second shaft with the first named shaft and disconnecting it therefrom, means for transmitting power to said second shaft, means for transmitting power from the first named shaft, a hub movable to two positions on the first shaft in one of which it is rotatable with it and the other independently of it, a gear on the hub, a gear connected with the second shaft for meshing with said gear on the hub when in position to rotate independently of the first shaft and out of mesh with it when the hub is in position to rotate with the first shaft, a lever for shifting said hub, a gear slidably mounted on said hub to be rotated thereby, a second lever for sliding said gear, a gear on the feed rod and a gear on the lead screw, said last two gears being in position to mesh with the slidable gear on the hub, one when it is in one position and the other when it is in the other position.

10. In a lathe, the combination of a shaft, a bank of gears thereon, a second shaft, two gears connected with said second shaft, one adapted to mesh with said bank of gears, a gear for transmitting power to the other gear on said second shaft, means for transmitting power to the first named shaft independently of said gears, two independent gears, a gear on the first named shaft adapted to mesh with either of the two last named gears, and means for moving the gear on the first shaft to simultaneously engage it with one of said two gears and disengage it from the other.

11. In a lathe, the combination of a pair of gears mounted to rotate together, a pair of shafts, a speed changing device connecting said shafts, gears slidably mounted on

said shafts and rotatable with them, each of said gears being adapted to mesh with one of the first named gears means for simultaneously bringing one of said gears on the shafts into mesh with one of the first named gears and the other out of mesh with the other, a lead screw, and means connected with one of said shafts for operating the lead screw.

12. In a lathe, the combination of a pair of gears mounted to rotate together, a pair of shafts, a speed changing device connecting said shafts, gears slidably mounted on said shafts and rotatable with them, each of said gears being adapted to mesh with one of the first named gears, means for simultaneously bringing one of said gears into mesh with one of the first named gears and the other out of mesh with the other, a lead screw, a gear connected with the lead screw for operating it means mounted on one of said shafts for operating the last named gear, said means being operated directly by the shaft on which it is mounted when power is transmitted thereto through the other shaft and operated by the other shaft when power is transmitted to the other shaft through the shaft carrying said means.

13. In a lathe, the combination of a pair of driving gears mounted to rotate together, a pair of shafts, a gear slidably mounted on each of said shafts and adapted to rotate it, means for meshing one of said sliding gears with one of the driving gears and the other sliding gear with the other driving gear, said sliding gears being so located that only one of them can be in mesh with its driving gear at the same time, speed changing mechanism between said shafts, a lead screw, means for transmitting power to the lead screw comprising a hub on one of said shafts, means whereby said hub is rotated with the shaft on which it is mounted when the gear on the other shaft is in mesh with its driving gear, and means whereby said hub is rotated independently of the shaft on which it is mounted when the shaft on which the hub is mounted is rotated directly by its driving gear.

14. In a screw-cutting lathe, the combination of speed changing devices, a gear connected therewith to receive power therefrom, a second gear fixed to the first gear and having a definite ratio thereto, two shafts, one of which constitutes a gear bank shaft, means for connecting each of said shafts with one of said gears, a bank of gears on the gear bank shaft, means connected with the other shaft for rotating it from said gear bank shaft, a lead screw, means connected with said gear bank shaft for turning the lead-screw, and means connected with the other shaft for operating the lead-screw when the gear-bank shaft is directly connected with one of the first named gears.

15. In a screw-cutting lathe, the combination of devices for transmitting power from the head-spindle, a gear connected therewith to receive power therefrom, a second gear fixed to the first gear and having a ratio thereto of 100 to 127, a gear bank shaft, a second shaft, means for connecting each of said shafts with one of said gears, a bank of gears on the gear bank shaft, a gear connected with the other shaft for meshing with the gears of said bank, a lead screw, means operated by said gear bank shaft for turning the lead screw, and means operated by the other shaft for rotating the lead screw when the gear bank shaft is directly connected with one of the first named gears.

16. In a screw-cutting lathe, the combination of power transmitting devices, a gear connected therewith to receive power therefrom, a second gear fixed to rotate with the first gear and having a definite ratio thereto, a gear bank shaft, means for connecting the gear bank shaft with said second gear, a bank of gears on the gear bank shaft, a second shaft, a gear connected with the second shaft and adapted to mesh with the gears on the gear bank shaft, a lead screw, means connected with the gear bank shaft for turning the lead screw, and means connected with the second shaft for operating said turning means.

17. In a screw-cutting lathe, the combination of power transmitting devices, a gear connected therewith to receive power therefrom, a second gear fixed to rotate with the first gear and having a ratio thereto of 100 to 127, a gear bank shaft, means for connecting the gear bank shaft with the smaller of said gears, a bank of gears on the gear bank shaft, a second shaft, a gear connected with the second shaft and adapted to mesh with the gears on the gear bank shaft, means for turning the lead screw from the gear bank

shaft, and means connected with the second shaft for operating said turning means. 45

18. In a screw-cutting lathe, the combination of power transmitting devices, a gear connected therewith to receive power therefrom, a second gear fixed to rotate with the first gear and having a definite ratio thereto, a gear bank shaft, means for connecting the gear bank shaft with said second gear, a bank of gears on the gear bank shaft, a second shaft, means for driving the second shaft from the gears on the gear bank shaft, a lead screw, means operated by the gear-bank shaft for turning the lead screw, means connected with the second shaft for operating said turning means, and means for disconnecting the gear bank shaft from said second gear and simultaneously connecting the second shaft with the first gear. 50 55 60

19. In a screw cutting lathe, the combination of power transmitting devices, a gear connected therewith to receive power therefrom, a second gear fixed to rotate with the first gear and having a definite ratio thereto, a gear bank shaft, means for connecting the gear bank shaft with said second gear, gears on the gear bank shaft, a second shaft, means connected with the second shaft for transmitting power thereto from the gear bank shaft, a screw or rod, means on the gear bank shaft for turning the screw, or rod, means connected with the second shaft for operating said turning means, and means for simultaneously disconnecting the turning means from the second shaft and operatively connecting it with the gear bank shaft. 65 70 75

In testimony whereof I have hereunto set my hand, in the presence of two subscribing witnesses. 80

FRED K. HENDRICKSON.

Witnesses:

A. E. FAY,  
C. FORREST WESSON.