

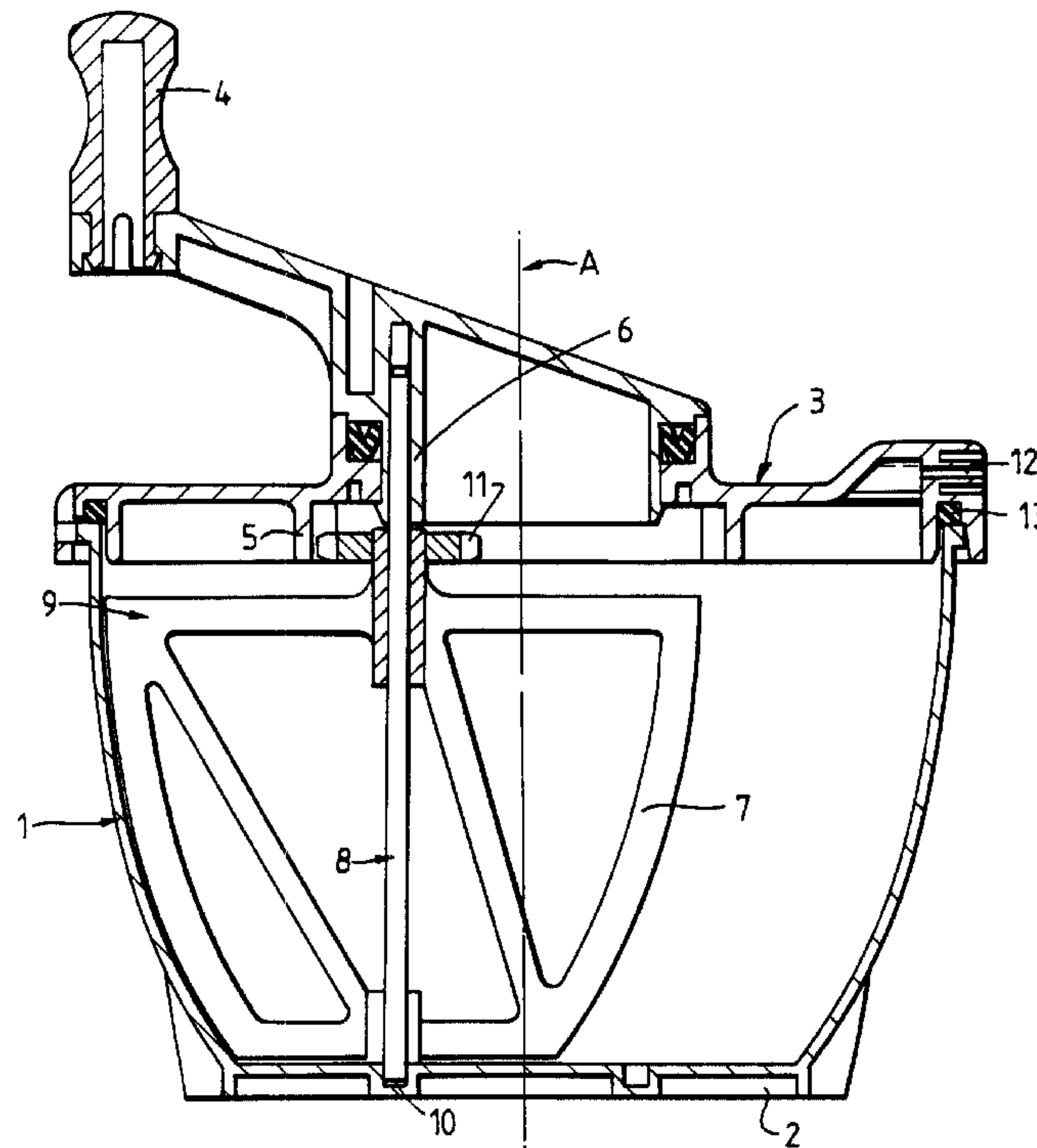

(86) Date de dépôt PCT/PCT Filing Date: 1992/12/04  
 (87) Date publication PCT/PCT Publication Date: 1993/06/10  
 (45) Date de délivrance/Issue Date: 2003/12/02  
 (85) Entrée phase nationale/National Entry: 1994/06/03  
 (86) N° demande PCT/PCT Application No.: GB 1992/002259  
 (87) N° publication PCT/PCT Publication No.: 1993/010892  
 (30) Priorité/Priority: 1991/12/06 (9126011.7) GB

(51) Cl.Int.<sup>5</sup>/Int.Cl.<sup>5</sup> B01F 7/30  
 (72) Inventeur/Inventor:  
 SEDDON, PETER, GB  
 (73) Propriétaire/Owner:  
 SUMMIT MEDICAL LIMITED, GB  
 (74) Agent: EVERITT, PETER R.

(54) Titre : DISPOSITIF POUR LE MELANGE D'UN CIMENT A OS  
 (54) Title: BONE CEMENT MIXING DEVICE



(57) Abrégé/Abstract:

An orthopaedic bone cement mixing device comprising a mixing bowl (1) and a lid (3), said lid (3) having a handle (4) extending outwardly therefrom. A mixing paddle (7) comprising a shaft (8) and vanes (9) extending outwardly therefrom extends into the bowl (1) from the lid (3) and is anchored in a groove (10) running around the base (2) of the bowl. A step-up gear mechanism (5, 11) is provided between the paddle (7) and the lid (3) such that, as the handle (4) is rotated, the lid (3) rotates, causing the paddle (7) to rotate around the bowl (1). The drive wheel (5) of the gear mechanism is also caused to rotate and drives the driven wheel (11) which causes the shaft (8) of the paddle (7) to rotate about its own axis as the paddle (7) moves around the bowl (1).



INTERNATIONAL APPLICATION PUBLISHED UNDER THE PATENT COOPERATION TREATY (PCT)

<b>(51) International Patent Classification<sup>5</sup> :</b>  <b>B01F 7/00</b>	<b>A1</b>	<b>(11) International Publication Number:</b> <b>WO 93/10892</b>  <b>(43) International Publication Date:</b> 10 June 1993 (i... 3)
<b>(21) International Application Number:</b> PCT/GB92/02259 <b>(22) International Filing Date:</b> 4 December 1992 (04.12.92)  <b>(30) Priority data:</b> 9126011.7                      6 December 1991 (06.12.91)    GB  <b>(71) Applicant (for all designated States except US):</b> SUMMIT MEDICAL, LTD. [GB/GB]; Industrial Park, Bourton on the Water, Gloucestershire GL54 2HQ (GB).  <b>(72) Inventor; and</b> <b>(75) Inventor/Applicant (for US only) :</b> SEDDON, Peter [GB/GB]; The Manor Farmhouse, Stanley Pontlarge, Winchcombe, Gloucestershire GL54 5HD (GB).  <b>(74) Agent:</b> DAVIES, Christopher, Robert; Frank B. Dehn & Co., Imperial House, 15-19 Kingsway, London WC2B 6UZ (GB).	<b>(81) Designated States:</b> AU, BR, CA, FI, GB, JP, NO, US, European patent (AT, BE, CH, DE, DK, ES, FR, GB, GR, IE, IT, LU, MC, NL, PT, SE).  <b>Published</b> <i>With international search report.          Before the expiration of the time limit for amending the claims and to be republished in the event of the receipt of amendments.</i>	

**(54) Title:** BONE CEMENT MIXING DEVICE**(57) Abstract**

An orthopaedic bone cement mixing device comprising a mixing bowl (1) and a lid (3), said lid (3) having a handle (4) extending outwardly therefrom. A mixing paddle (7) comprising a shaft (8) and vanes (9) extending outwardly therefrom extends into the bowl (1) from the lid (3) and is anchored in a groove (10) running around the base (2) of the bowl. A step-up gear mechanism (5, 11) is provided between the paddle (7) and the lid (3) such that, as the handle (4) is rotated the lid (3) rotates, causing the paddle (7) to rotate around the bowl (1). The drive wheel (5) of the gear mechanism is also caused to rotate and drives the driven wheel (11) which causes the shaft (8) of the paddle (7) to rotate about its own axis as the paddle (7) moves around the bowl (1).

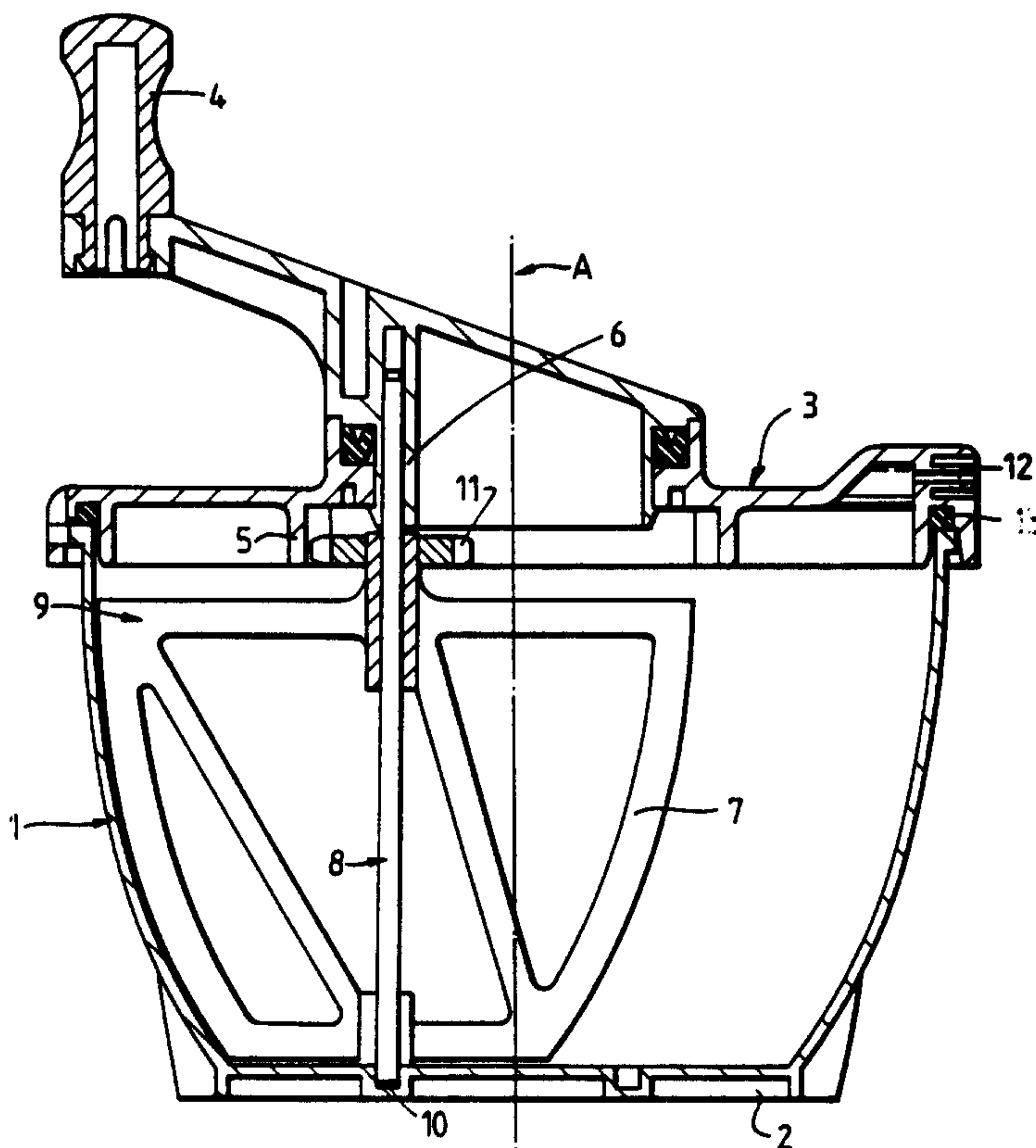

**2125165**

- 1 -

Bone Cement Mixing Device

The present invention relates to a device for mixing orthopaedic bone cement or the like.

Orthopaedic bone cement is used throughout the world to secure hip, knee and other metallic prostheses in an appropriate anatomical position. The bone cement is produced by thoroughly mixing together two components, usually methylmethacrylate monomer liquid and polymethylmethacrylate powder. The mixing is usually carried out using a simple bowl and spatula. The surgeon then removes the required amount of cement and manipulates it by hand before inserting it into a preformed cavity or applying it to a resected bony surface where the prosthesis is to be positioned. Cement may either be applied by hand or may be put into a syringe and applied thereby. However, this simple mixing method has two major drawbacks.

Firstly, free methylmethacrylate fumes are emitted from the mixture. It is desirable to remove these fumes, or prevent them from escaping into the atmosphere, since they have an unpleasant odour and may be harmful to operating room personnel. The fumes are known to cause nausea and giddiness and are generally objectionable, particularly to the nurses who actually carry out the mixing. Recently there has also been concern that long term exposure to these fumes results in a more serious health risk. Current employment law relating to occupational health means medical staff must now be protected against the exposure to hazardous substances.

**2125165**

- 2 -

Secondly, a very high mixing efficiency is required to produce a homogenous cement material. During the mixing process air is naturally introduced into the mixture since air is inherently existent within the powder and also in and around the mixing vessel. Air bubbles are also produced by the "boiling off" of monomer which occurs during the mixing process. The introduction of air produces a weak cement and, since the joint must usually support a heavy load, it is important to reduce the amount of air in the mixture as much as possible in order to improve the mechanical strength of the cement material.

In order to eliminate as much air as possible from the mixture mixing is now preferably carried out under vacuum. This considerably reduces the amount of air in the mixture. Mixing in a conventional bowl and spatula system can produce a product with a porosity value of approximately 20 to 25%. In a vacuum mix, the porosity is often reduced to levels below 5%.

Several devices for mixing the cement in a vacuum are presently available. The most successful of these combine a mixing chamber with a syringe. For example, EP-A-0178658 discloses a device for mixing bone cement comprising a mixing container connected to a feed device. A vacuum source is connected to the feed device for mixing the substances under vacuum. This device has proved to be a very efficient mixing and transfer system and eliminates the need to transfer the mixed cement from the mixing bowl to a syringe, which can be messy and time

**2125165** - 3 -

consuming and may expose the mixture to more air entrapment.

However, these combined mixer/syringe devices are expensive. Further, they are restricted to applying the  
5 cement by a syringe, whereas the majority of surgeons prefer to "hand pack" the cement. Bowl mixing also tends to be preferred by nurses who are used to the convenience of mixing in this vessel; a bowl is easier to use and it is important that the nurses feel confident since timing  
10 is very crucial and the mixture must be 'right first time'. Mixer/syringe devices may, therefore, have more potential for failure. Surgeons also tend to prefer bowl mixers because they can easily take samples of the cement from the bowl at any time to determine the progress of  
15 polymerisation as it is crucial that the mixture does not begin to set before it is applied.

Thus, the mixer/syringe devices have practical and economical limitations and a bowl mixer is a more attractive option.

20 Bowl mixing devices have been proposed which comprise a mixing bowl with a lid. A mixing paddle extends from the lid into the bowl and is rotated by means of a handle on the outside of the lid. A vacuum source is connected to the bowl to create a vacuum in the  
25 mixing bowl. However, this device has been found to be inadequate in that 'dead spots', i.e. areas where the components are not sufficiently mixed, occur, particularly in the middle of the bowl. There may also

**2125165 - 4 -**

be a tendency for mixing paddles to break when faced with the challenge of a high viscosity material.

Problems have also arisen with regard to the capacity of known mixers. Several different types of cement are commonly used in Orthopaedic applications and it is desirable that a mixer should have the capacity to mix a sufficient quantity of any of these types. In particular, some of the cement used in the USA may be more bulky than the other cements and it has been found that known mixers cannot mix sufficient quantities efficiently, especially if larger amounts of cement are required such as in a revision operation which may require a triple mix.

According to one aspect of the present invention there is provided a hand-held mixing device for bone cement or the like, comprising an enclosed mixing chamber, a port in a wall of said chamber for connection to a vacuum source in use to enable a vacuum to be created in said chamber, a mixing paddle extending into said chamber, and a rotatable handle coupled to said paddle by a gear mechanism arranged such that rotation of said handle causes said paddle to rotate about its own axis and also moves the axis of rotation of the paddle within the chamber whereby the paddle is moved around substantially the entire cement containing region of the interior of the chamber.

By means of this arrangement an improved mixing action may be achieved in e.g. a bowl type mixing device which mixes the cement thoroughly and can be used more

**2125165**

- 5 -

effectively than known devices to mix both small and large quantities of cement.

In a particularly preferred embodiment, the gear mechanism is a step-up gear such that a single rotation of the handle produces a plurality of rotations of the paddle about its own axis. Whilst the drive mechanism for moving the axis within the chamber may vary, as indeed may the path of such movement, it is preferred that the pivot axis is coupled to the handle in such a way that it describes a circle with each rotation of the handle causing a single planetary rotation of the pivot axis about the axis of rotation of the handle. It is preferable, on the other hand, that the number of stepped up rotations of the paddle about its own axis produced by a single rotation of the handle is not a whole number so that the paddle ends up in a different orientation after each turn of the handle to increase the mixing efficiency and avoid dead spots.

In order to reduce the amount of air in the mixture, and to prevent noxious fumes escaping, the chamber should preferably be completely sealed from the surrounding environment when in use.

A preferred structure comprises a hand-held mixing bowl with a removable lid which fits over the bowl and can preferably be locked to ensure the lid is held securely on the bowl during mixing. The handle is rotatably mounted in the lid and extends outwardly therefrom to be rotated by the user. A seal may also be provided between the lid and the rim of the bowl to

2125165

- 6 -

ensure that the mixing chamber is completely air-tight and that no fumes can escape.

The form of the gear mechanism may vary. In a preferred embodiment, the paddle is carried by an axle  
5 which is eccentrically coupled to the handle as discussed. A circular rack fixed to the underside of the lid, and arranged coaxially with the rotation axis of the handle, drivingly co-operates with a cog wheel associated with the paddle to rotate the paddle as the handle is  
10 turned. Such an arrangement minimises the number of moving parts required.

Most thorough mixing is provided by a mixing paddle comprising a shaft and a plurality of vanes extending outwardly from the shaft. At least one vane should, for  
15 best results, extend out to the edge of the bowl and conform to the shape of the interior of the bowl; other vanes may extend into the bowl by different amounts. However, since the paddle both moves around the bowl and rotates about its own axis, even a single vane could  
20 provide thorough mixing in smaller systems.

As the cement is mixed it begins to thicken and this may cause the mixing vane to bend. To overcome this, a guide groove may be provided in the base of the mixing bowl in which the base of the paddle, or its axle, is  
25 supported as it rotates around the bowl. This groove anchors the paddle and keeps it upright even when the cement thickens.

Since every mixture will have slightly different characteristics and will begin to set at different times



**2 1 2 5 1 6 5**

- 7 -

and since different circumstances often require cements at different stages of setting it is preferable that the surgeon can observe the cement during mixing without interrupting the mixing process or exposing the cement to  
5 air. Therefore it is preferable that the bowl is transparent or has a transparent window through which the cement can be observed.

In a preferred embodiment, gases emitted from the mixture are drawn off through a valve and filter  
10 arrangement which may comprise a separate, one-way valve and a charcoal filter, or an integrated valve/filter comprising a fibre material impregnated with activated charcoal. Such a filter means itself represents a new departure.

15 The outlet port for evacuating the chamber may be provided in the bowl or in the lid in the preferred embodiment, and preferably includes a male push fit or other connector for engagement in use with a hose leading to a vacuum pump.

20 According to another aspect of the invention there is provided a mixing system for bone cement or the like comprising a mixing chamber, a mixing paddle extending into said chamber, a handle rotatably mounted with respect to said chamber, said handle being connected to  
25 said paddle to cause rotation of said paddle, means for evacuating air from said chamber comprising a port in a wall of said chamber and a vacuum pump connected to said port, filter means adapted to remove unwanted fumes from air removed from said chamber, said filter means

2125165

- 8 -

comprising either an activated charcoal medium or non-woven fibre material impregnated with a filtering substance such as activated charcoal.

Viewed from a further aspect the invention provides  
5 a mixing system for bone cement or the like comprising an enclosed mixing chamber communicating with a vacuum pump for removing air from the chamber in use, and a mixing mechanism comprising a mixing paddle driven by a handle which causes rotation of the paddle about an axis and  
10 simultaneously causes movement of the axis within the chamber.

Viewed from a still further aspect the invention provides a method of mixing bone cement or the like within an evacuated environment, which comprises moving  
15 the axis of a rotating mixing element within the mixture during mixing.

A preferred embodiment of the invention will now be described by way of example only and with reference to the accompanying drawings wherein:

20 Fig. 1 shows a perspective view of a bone cement mixing device according to the present invention;

Fig. 2 shows a cross-section of the device of Fig. 1;

Fig. 3 shows a plan view of the device of Fig. 1;

25 Fig. 4 shows the gear mechanism of the device of Fig. 1; and

Fig. 5 shows a cross-section of a preferred embodiment of the mixing device including an integral valve/filter assembly.

**2125165** - 9 -

Referring to Figs. 1 to 5, the mixing device comprises a mixing bowl 1 having a base 2 and an open top. A lid 3 is adapted to fit and seal the top of the bowl 1. The lid 3 is provided with a handle 4, rotatably mounted in, and extending outwardly from the lid 3. The under side of the lid is provided with a fixed, circular, toothed rack 5 which is coaxially arranged with respect to the rotation axis A of the handle. A socket 6 is provided in the underside of the handle 4, eccentrically with respect to the central axis A. The device also includes a mixing paddle 7 mounted on an axle 8 supporting mixing vanes 9 extending outwardly therefrom. The axle 8 is rotatably mounted, at one end, in the socket 6 in the handle 4. The other end of the axle 8 fits into a circular groove 10 around the base 2 of the bowl 1. A cog wheel 11 is fixedly attached to the upper part of the axle 8 for intermeshing engagement with the toothed rack 5. The lid 3 is also provided with a vacuum port 12 for connection to a vacuum pump (not shown). The lid 3 is preferably provided with a seal 13, for sealing between the lid 3 and the rim of the bowl 1, and locking means 14 to hold the lid 3 securely in place during mixing.

The substances to be mixed are placed in the mixing bowl 1. The lid 3 is then placed on the bowl and locked. The vacuum port 12 is connected, via a length of PVC tubing 15, to a vacuum pump (not shown) to create a vacuum in the bowl 1. The preferred operating vacuum is in the range of 0.7 to 0.9 bar, and is most preferably

2125165

- 10 -

0.75 bar. To mix the components, the operator rotates the handle 4 which causes planetary movement of the axle 8 about the central axis A and at the same time causes the cog wheel 11 to mesh with the rack 5 so to drive the 5 cog wheel 11, producing rotation of the paddle 7 about the axis of the axle 8. Thus, due to the gear mechanism provided by the toothed rack 5 and the cog wheel 11, rotation of the handle 4 causes the paddle 7 to move around the bowl 1 in planetary fashion and, at the same 10 time, to rotate about its own axis. Such a mechanism enables the paddle 7 to rotate several times for each turn of the handle 4 and results in a more than 90% coverage of the bowl area. One rotation of the handle 4 does not cause a whole number of rotations of the paddle 15 7, such that the paddle 7 is in a different orientation at the beginning and end of a particular cycle of the axle movement; this helps to avoid dead spots being formed in the cement and improves mixing.

At least one of the vanes 9 should extend from the 20 axle 8 to the wall of the bowl 1; other vanes 9 may only extend partway across the bowl 1.

The base of the axle 8 travels around the bowl 1 in a groove 10 provided in the base 2 of the bowl to provide support, strength and stability to the paddle 7. The 25 groove 10 ensures that the paddle 7 always remains upright and does not bend when the cement becomes thick.

The mixing bowl 1 is preferably made of clear plastic to enable the user to observe the progress of the cement as it is mixed.

**2125165** - 11 -

During mixing, the noxious methacrylate fumes are drawn off through the PVC tubing 15 and filtered. This may be done in the conventional way via a one-way valve 16, which prevents the fumes returning to the bowl 1, and an activated charcoal filter 17. Alternatively an integrated valve/filter assembly could be used which comprises a non-woven fibre material impregnated with activated charcoal. This is a much more efficient and convenient system which does not involve the use of charcoal granules.

When the cement is ready, the lid 3 is removed and the cement may be directly applied to the bone site by hand or may be transferred to a syringe for syringe application as preferred.

- 12 -

## CLAIMS

1. A hand-held mixing device for bone cement,  
comprising an enclosed mixing chamber (1), a lid (3)  
5 which fits over said chamber (1), a port (12) in a wall  
of said chamber for connection to a vacuum source in use  
to enable a vacuum to be created in said chamber (1), a  
mixing paddle (7) extending into said chamber (1), and a  
rotatable handle (4) coupled to said paddle (7) by a  
10 gear mechanism (5, 11) arranged such that rotation of  
said handle (4) causes said paddle (7) to rotate about  
its own axis; characterised in that said paddle (7) is  
carried by an axle which is eccentrically coupled to the  
handle (4) such that rotation of said handle (4) also  
15 moves the axis of rotation of the paddle (7) within the  
chamber (1), whereby the paddle is moved around  
substantially the entire cement containing region of the  
interior of the chamber (1), and wherein the number of  
rotations of the paddle (7) about its own axis produced  
20 by a single rotation of the handle is not a whole number  
so that the paddle ends up in a different orientation  
after each single full rotation of the handle (4).

2. A hand-held mixing device as claimed in claim 1  
25 wherein the mixing chamber is in the form of a bowl.

3. A hand-held mixing device as claimed in claim 1 or  
2 wherein said gear mechanism (5, 11) is a step-up gear  
such that a single rotation of the handle (4) produces a  
30 plurality of rotations of the paddle (7) about its own  
axis.

4. A hand-held mixing device as claimed in claim 1 or  
claim 2 or claim 3, further comprising locking means  
35 (14) for securely holding said lid (3) in place during  
mixing.

- 13 -

5. A hand-held mixing device as claimed in claim 1 or claim 2 or claim 4 wherein said handle (4) is rotatably mounted in the lid (3) and extends outwardly therefrom to be rotated by the user.

5

6. A hand-held mixing device as claimed in claim 1 or claim 2 or claim 3 or claim 4 or claim 5 further comprising a circular rack (5) fixed to the underside of the lid (3), and arranged coaxially with the rotation axis of the handle (4) which drivingly co-operates with a cog wheel (11) which drives the paddle axle to rotate the paddle (7) as the handle (4) is turned.

10

7. A hand-held mixing device as claimed in claim 6 wherein said mixing paddle (7) comprises a shaft (8) and at least one vane (9) extending outwardly from the shaft, wherein such vane (9) extends to the edge of the chamber and conforms to the shape of the interior of said chamber.

15

20

8. A hand-held mixing device as claimed in claim 7 further comprising a guide groove (10) in the base of the chamber in which the base of the paddle (7), or an axle carrying the paddle, is supported as it rotates around the chamber.

25

9. A hand-held mixing device as claimed in any claim 1 to claim 8, wherein said chamber is at least partly transparent.

30

10. The use of a device as claimed in claim 9 in the mixing of bone cement.

FIG. 1

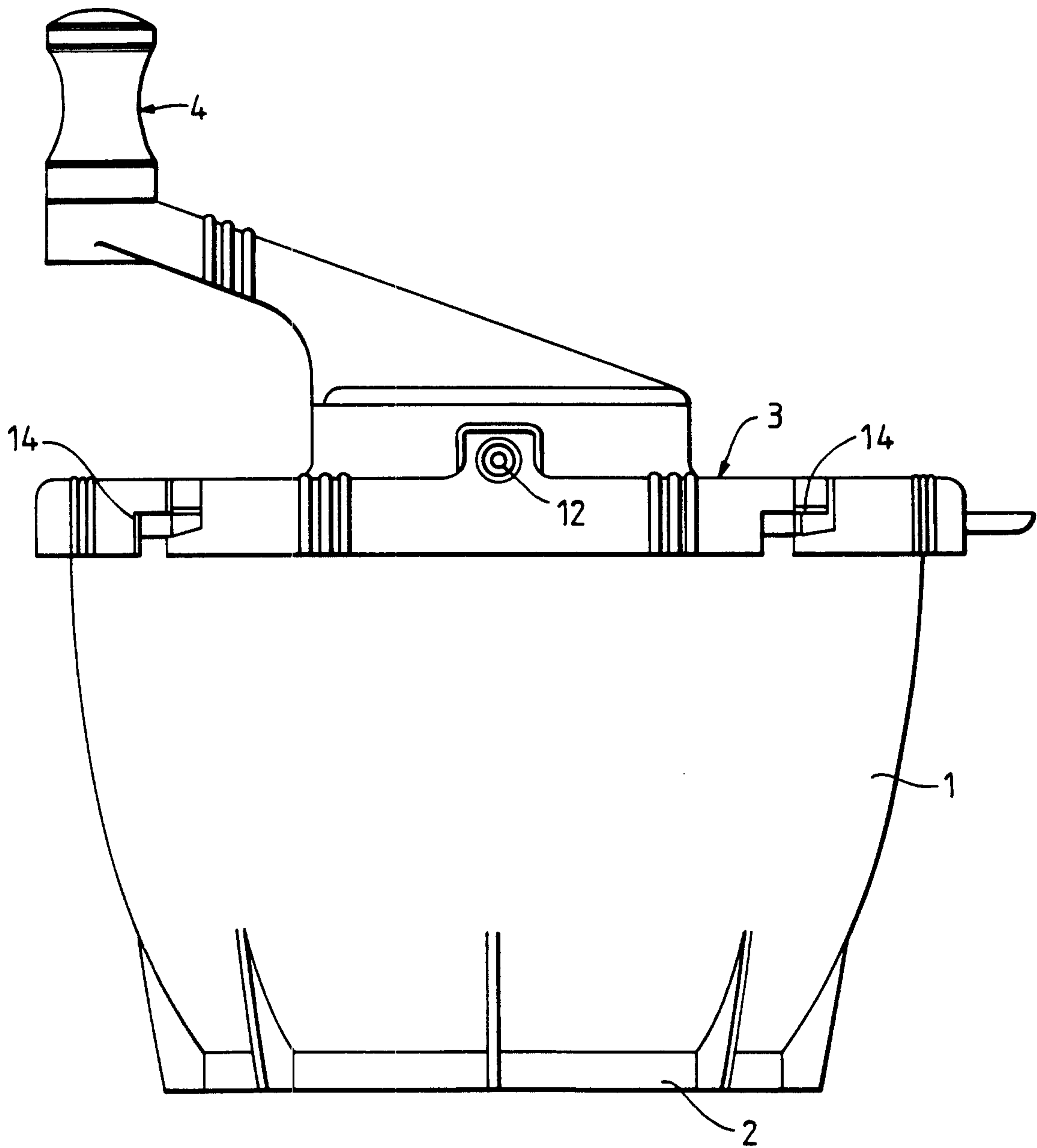



2125165

2/5

FIG. 2

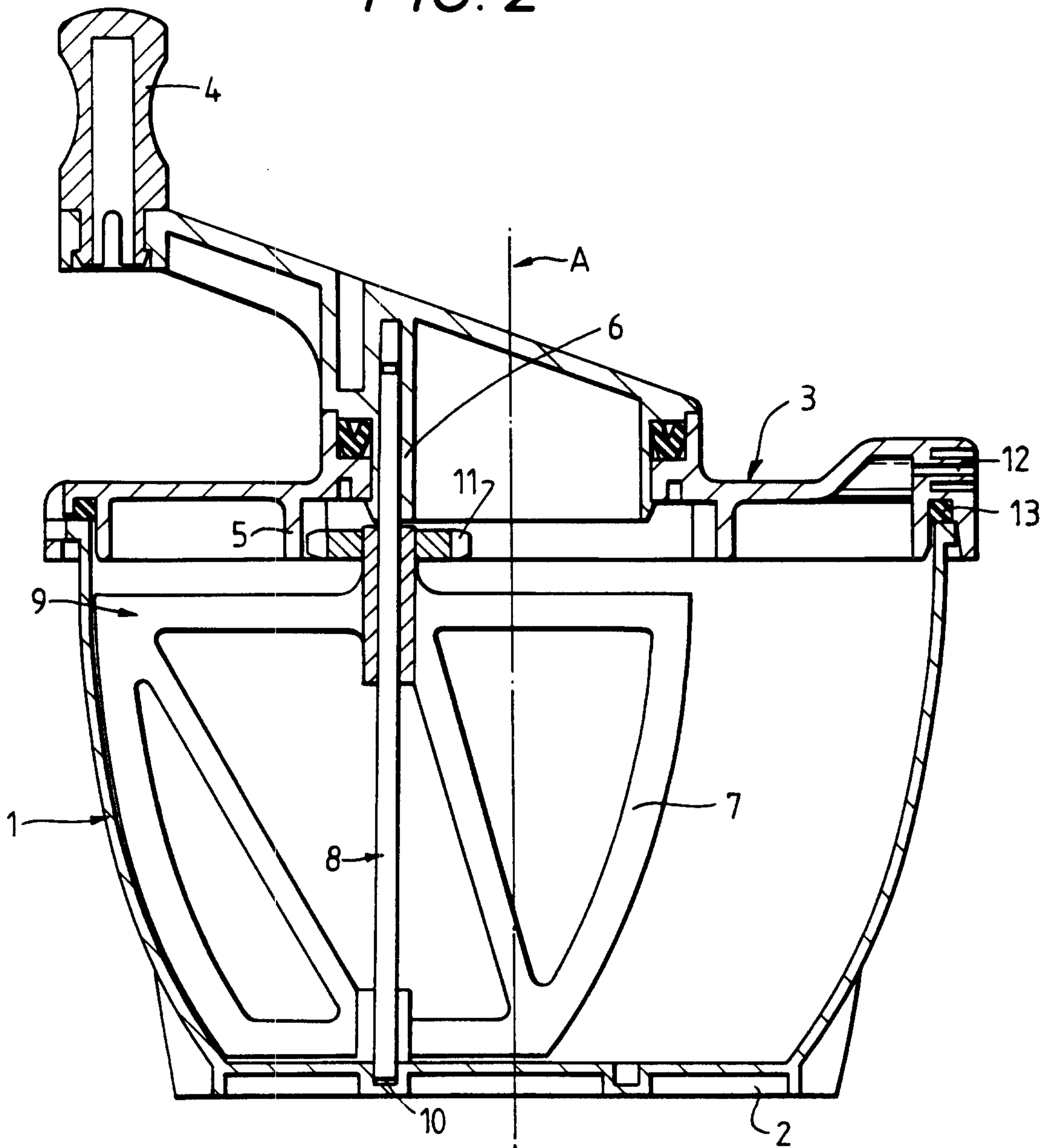

FIG. 3

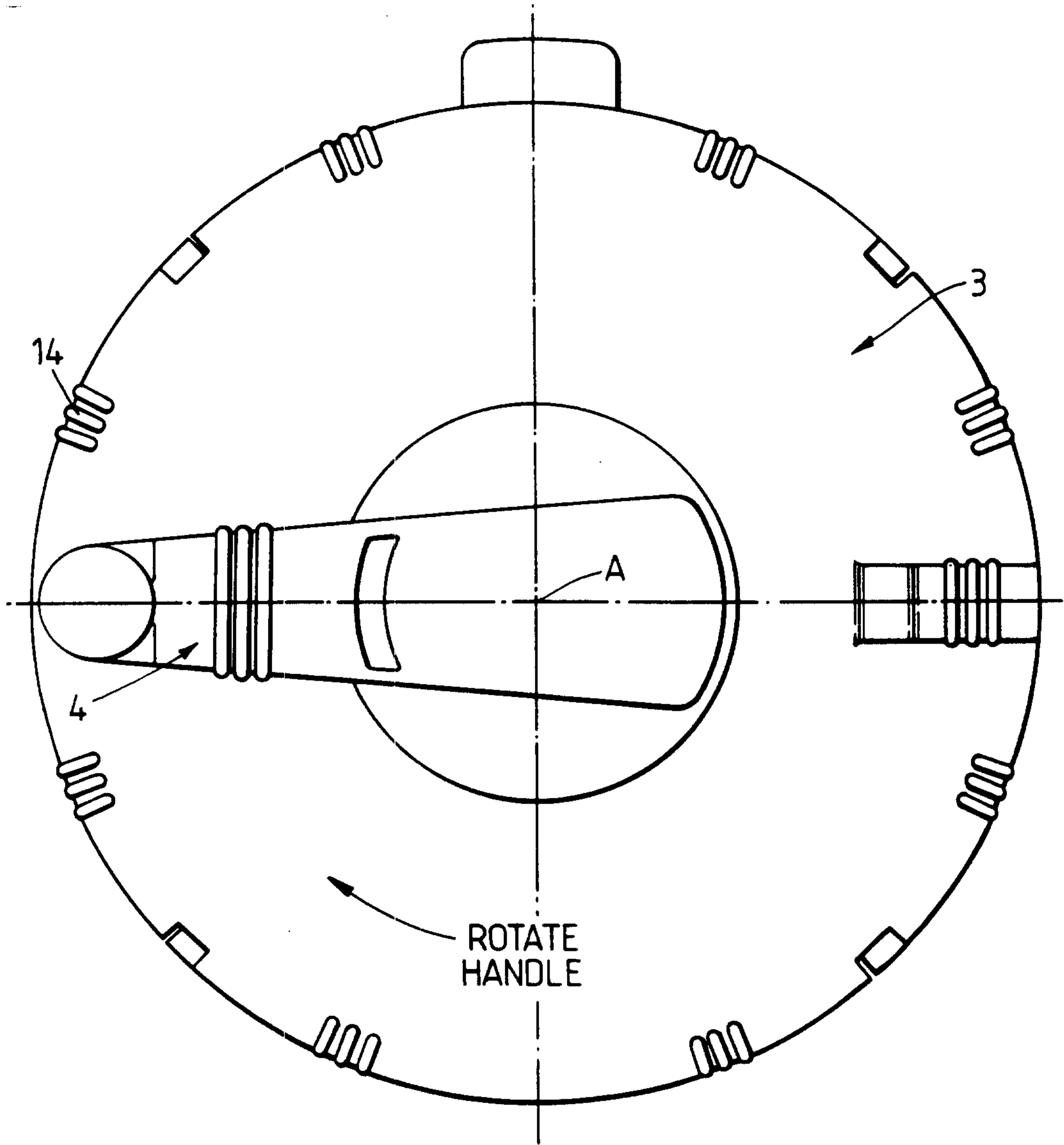
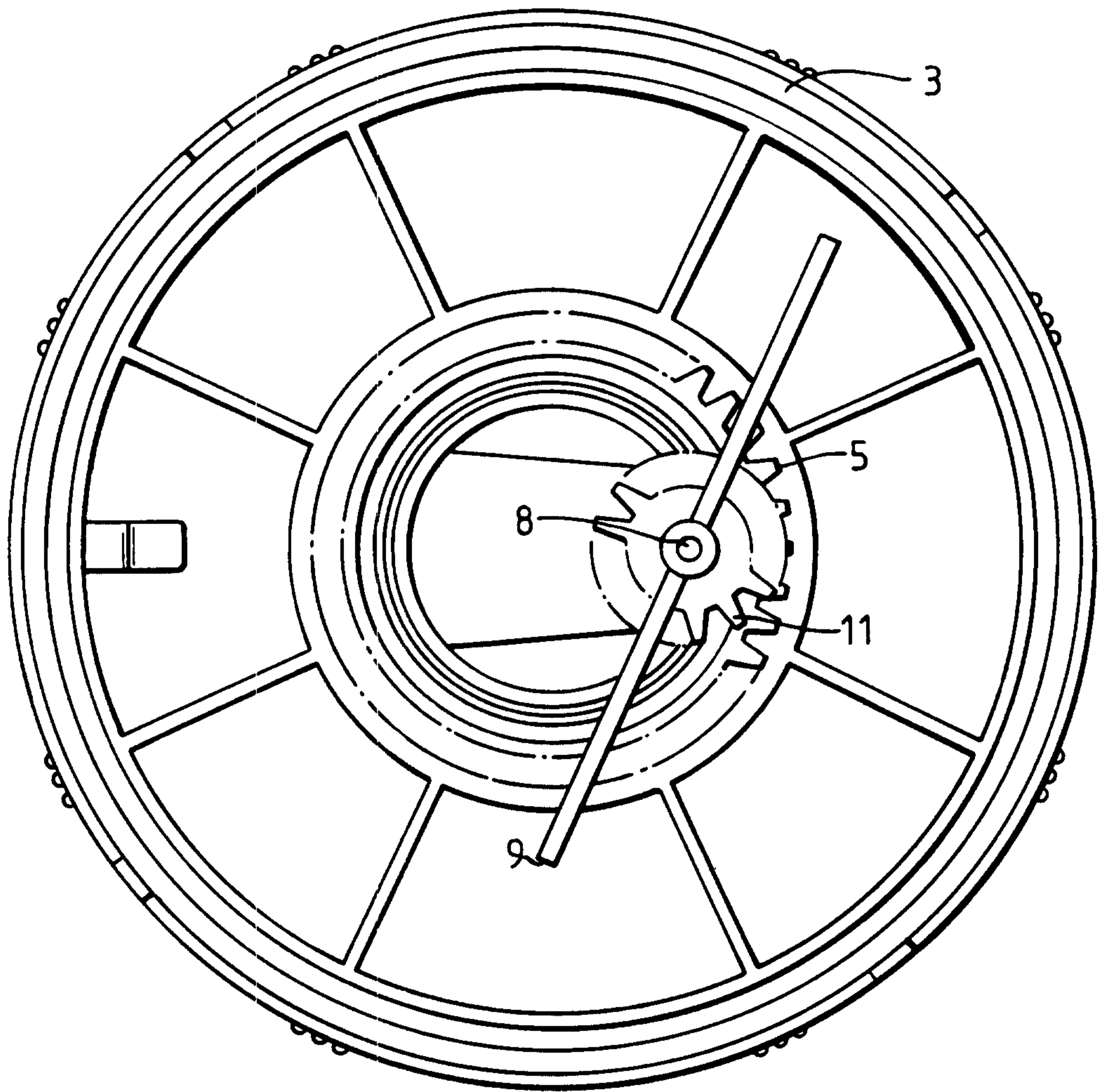

FIG. 4



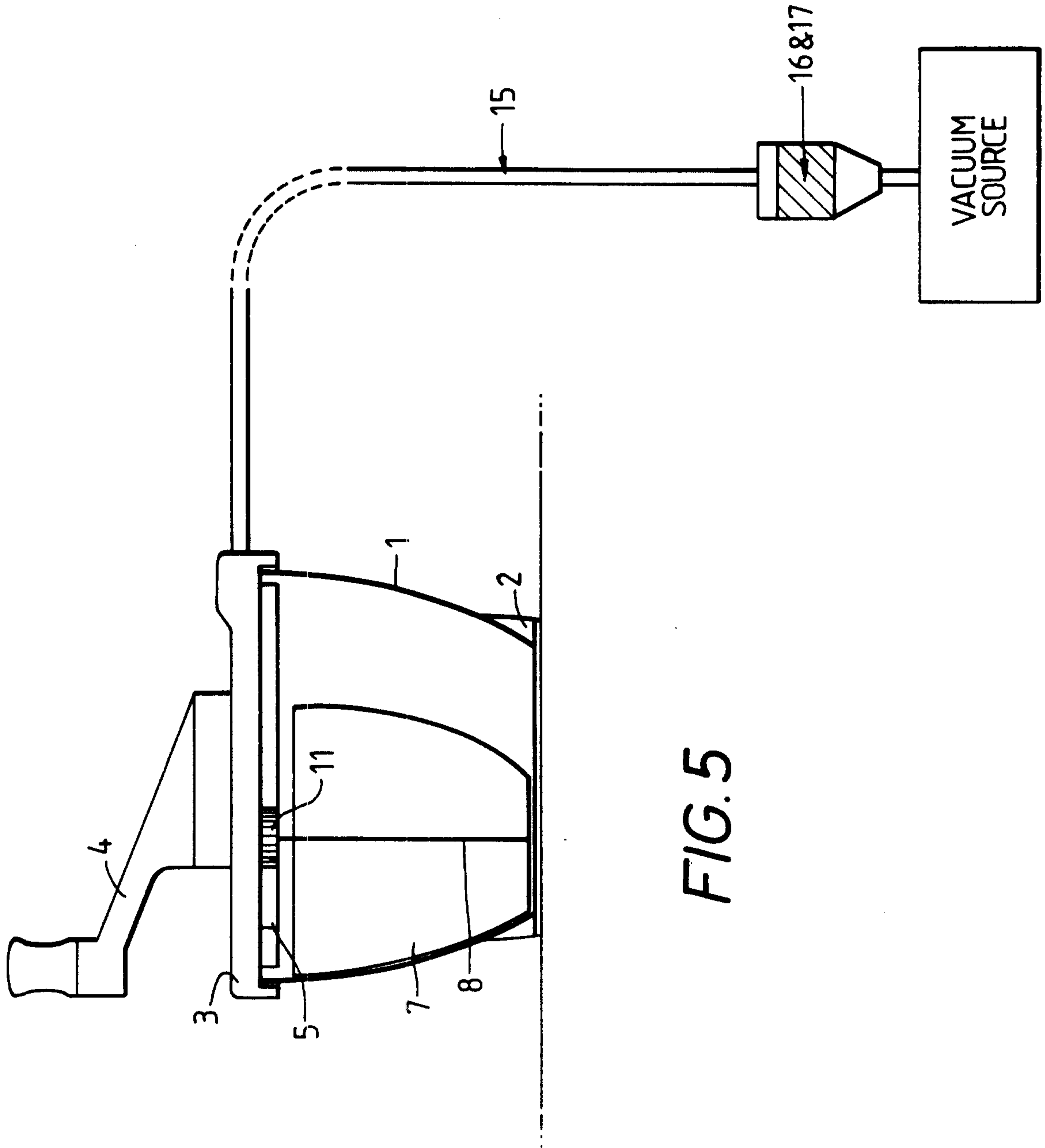

FIG. 5

