



(12) **DEMANDE DE BREVET CANADIEN
CANADIAN PATENT APPLICATION**

(13) **A1**

(86) Date de dépôt PCT/PCT Filing Date: 2018/08/20
(87) Date publication PCT/PCT Publication Date: 2019/03/07
(85) Entrée phase nationale/National Entry: 2020/01/29
(86) N° demande PCT/PCT Application No.: EP 2018/000405
(87) N° publication PCT/PCT Publication No.: 2019/042578
(30) Priorités/Priorities: 2017/08/29 (DE10 2017 008 148.4);
2017/09/15 (DE20 2017 004 822.1)

(51) Cl.Int./Int.Cl. *A61B 1/00* (2006.01)
(71) Demandeur/Applicant:
JOIMAX GMBH, DE
(72) Inventeurs/Inventors:
RIES, WOLFGANG, DE;
GERMANN, MARTIN, DE
(74) Agent: GOWLING WLG (CANADA) LLP

(54) Titre : DISPOSITIF ENDOSCOPIQUE
(54) Title: ENDOSCOPE DEVICE

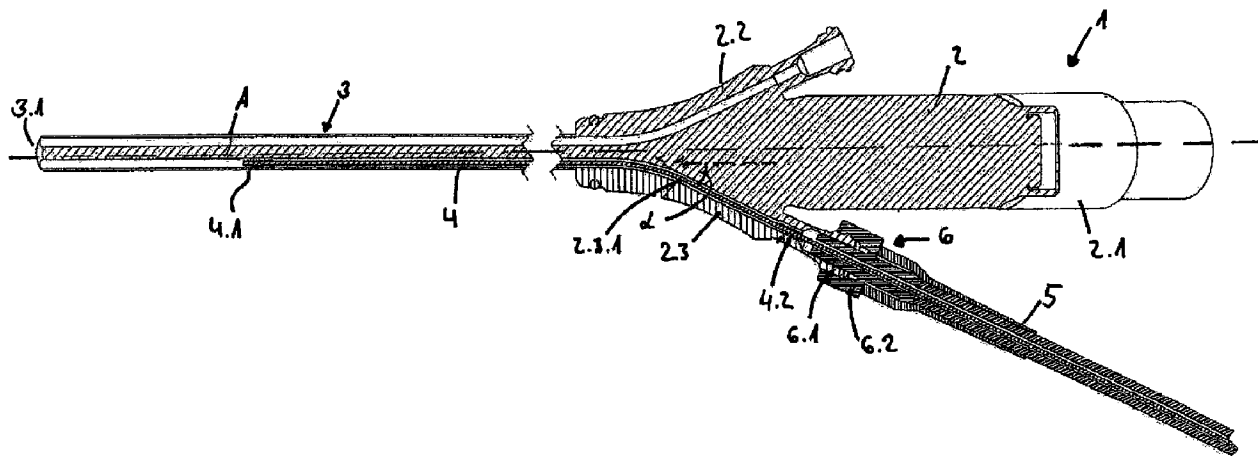

(57) **Abrégé/Abstract:**

The invention proposes, for determining the precise orientation and positioning of an endoscope in an electromagnetic field, an endoscope device having a proximal insertion head and having a shaft extending distally therefrom having a centre axis, which extends with at least one oblong lumen through the device, which is characterized by a sensor rod having at least two sensor coils arranged with finite spacing in relation to one another in the longitudinal direction, which are oriented in relation to one another at a finite angle.

Abstract

The invention proposes, for determining the precise orientation and positioning of an endoscope in an electromagnetic field, an endoscope device having a proximal insertion head and having a shaft extending distally therefrom having a centre axis, which extends with at least one oblong lumen through the device, which is characterized by a sensor rod having at least two sensor coils arranged with finite spacing in relation to one another in the longitudinal direction, which are oriented in relation to one another at a finite angle.

Endoscope device

The invention relates to an endoscope device having a proximal insertion head and having a shaft extending distally therefrom having a centre axis, which extends
5 with at least one oblong lumen through the device.

Minimally invasive operations are already carried out presently by means of navigation-assisted operating methods. Different navigation systems are used for this purpose. Active and passive systems are used. In active
10 systems, a part introduced into the body of a patient, such as an instrument or surgical tool, is provided with a transmitter, via which the position of the instrument or tool, in particular the distal end located at the engagement location, may be externally
15 determined. In passive systems, a field is generated, which is detected via a sensor, whereby the position and alignment of the instrument or surgical tool, in particular its distal end, can in turn be detected directly or indirectly. Direct detection of the distal
20 end of a surgical part includes the arrangement of the sensor on the distal end of the part itself; indirect detection includes the fixed rigid attachment of the sensor in a defined point, in particular axial position, on the surgical part. Inferences about the
25 position and possibly the orientation of the distal end can be seen on the basis of the measured sensor signal. In passive navigation, in particular electromagnetic navigation has proven itself, in which an
30 electromagnetic field is generated externally around the operation region, for example, by a generator of an electromagnetic field in a cushion on which the patient

- 2 -

lies. Coil-type sensors installed in the surgical part enable the locating of the instruments, whereupon a representation can be performed in CT or MRT images. This method does not include a radiation exposure and thus overall reduces the radiation exposure, also due to a reduced use of x-rays. The image quality is not impaired, nor can sensors be concealed, since they are not optical sensors. The freedom of movement of the operator is not restricted, as is the case with optical systems. The work of the operator is significantly facilitated.

The invention is based on the object of providing a device, in which the location and orientation of an endoscope, in particular of the distal end, can be precisely determined using the above-described system while avoiding the mentioned disadvantages.

The mentioned object is achieved according to the invention by an endoscope device of the type mentioned at the outset, which is characterized by a sensor rod having at least two sensor coils arranged in the longitudinal direction at a finite spacing in relation to one another, which are oriented in relation to one another at a finite angle.

Because the two sensor coils are arranged at a finite angle in relation to one another in the endoscope device, because of the different arrangement, the orientation of the endoscope device in the magnetic field of the detection system and thus also in space can be precisely determined.

- 3 -

In one preferred embodiment, it is provided in this case that the first sensor coil is oriented in parallel in relation to the centre axis and the second sensor coil is oriented at a finite angle in relation to the centre axis, wherein in particular the first sensor coil is arranged in the shaft and the second sensor coil is arranged in an attachment of the insertion head.

In one refinement, it is provided that the rod bearing the two sensor coils extends through a lumen of the device, wherein in particular the rod is connected in an axially fixed manner to a holder which is attachable to the attachment of the insertion head. In this way, the location of the one sensor coil, in particular the first sensor coil, is accurately defined in the endoscope device and therefore on the basis of the determination of the location of the first sensor coil by the detection system in the magnetic field, the exact determination of the precise location of the distal end of the sensor device and thus of the working location is also possible, since the spacing of the (first) sensor coil from the distal end of the endoscope shaft is fixedly predetermined in this manner.

Due to the fixed connection of the rod bearing the sensor coil to a separable holder, furthermore, on the one hand, after positioning, the rod bearing the sensor coil is removed, and the lumen occupied thereby for the positioning can be released for other usage purposes. Furthermore, the sensor device formed by the rod having the sensor coils is thus separable from the actual

- 4 -

endoscope and can be used in another way. This also enables simpler sterilization.

Further advantages and features of the invention result from the claims and from the following description, in which an exemplary embodiment of the invention is explained in detail with reference to the drawing. In this case, the single figure

shows an endoscope device according to the invention in longitudinal section

10 The endoscope device 1 according to the invention comprises in the illustrated exemplary embodiment a proximal insertion head 2 and a shaft 3 extending distally therefrom. In the illustrated exemplary embodiment, the insertion head 2 comprises three
15 branches or attachments 2.1 to 2.3, namely one attachment 2.1 for introducing a light guide from the proximal end of the device 1 up to its distal end and also two attachments 2.2, 2.3, which each also comprise a lumen or a channel which extends from the distal end
20 of the elongated shaft 3 with a centre axis A up to an exit from the respective adapter 2.2, 2.3.

A rod 4, which bears two coils 4.1 and 4.2 with spacing in its longitudinal extension, extends through the lumen 2.3.1 of the attachment 2.3. The rod can be
25 formed as a solid or flexible rod or also as a rod coiled in a helix. A connecting wire (not shown) extends from each of the coils 4.1, 4.2 in the proximal direction up to a respective proximal connecting or contact end of the respective wire, possibly in the

- 5 -

formation of a plug for connection of the wires to an analysis unit (not shown).

The coil 4.1 is located at the distal end of the rod 4 and thus inside the shaft 3 extending in parallel to its centre axis A and is therefore also oriented in parallel to the centre axis A or axially-parallel. The coil 4.2 arranged with spacing in relation to the coil 4.1 on the rod 4 is located in the attachment 2.3 of the insertion head extending at a finite angle in relation to the centre axis A. In that the lumen section of the lumen 2.3.1 also extends at a finite angle in relation to the centre axis A, the orientation or extension of the coil 4.2 in the attachment 2.3 also encloses a finite angle in relation to the centre axis A. The two coils 4.1, 4.2 are therefore not parallel to one another, but rather are oriented at a finite angle in relation to one another.

In the case of an externally applied inhomogeneous electromagnetic field, in which the coils 4.1, 4.2 are located, these coils therefore perceive the field differently and transmit different signals to the analysis unit. Due to this different orientation of the coils 4.1, 4.2, the orientation of the endoscope device in the electromagnetic field and thus in space can therefore be exactly determined.

The rod 4 is arranged axially fixed in a holder 5. The holder 5 and the attachment 2.3 are connectable to one another by a Luer adapter 6, wherein each of the parts bears a respective part 6.1, 6.2 corresponding to one another of the Luer adapter 6, so that the attachment

- 6 -

2.3 and the holder 5 can be fixedly connected to one another like a bayonet by the Luer adapter 6 in a way known per se. The location of the holder 5 in relation to the attachment 2.3 and also in relation to the head 2 and the shaft 3 of the endoscope device 1 is thus defined in the fastened state. Since the shaft 4, as stated, is arranged axially fixed in the holder 5, the longitudinal position of the coils 4.1, 4.2 and in particular of the distal coil 4.1 in the shaft 3 and thus the endoscope device 1 is therefore also defined and therefore the spacing, in particular the axial spacing of the coil 4.1 from the distal end 3.1 of the shaft 3, is also defined. By way of the sensor signal of the coil 4.1 in the applied electromagnetic field, its location and, because of the fixed spacing in relation to the distal end 3.1 of the shaft 3, the location of the distal end 3.1 of the shaft 3 in the electromagnetic field and thus in space can also thus be determined.

An operator therefore recognizes, on the basis of the analysis of the sensor signals and an image display on a display screen of the analysis unit, the position of the distal end 3.1 of the shaft 3 and thus also of the endoscope device 1 accurately and thus knows where exactly they are working with their instruments, which they possibly introduce into other lumens of the endoscope device and through them.

Patent Claims

1. Endoscope device (1) having a proximal insertion head (2) and having a shaft (3) extending distally therefrom having a centre axis (A), having at least one oblong lumen (2.3.1) extending through the device (1), characterized by a sensor rod (4) having at least two sensor coils (4.1, 4.2) arranged at a finite spacing in relation to one another in the longitudinal direction, which are oriented in relation to one another at a finite angle (L).
2. Device according to Claim 1, characterized in that the first sensor coil (4.1) is oriented in parallel to the centre axis (A) and the second sensor coil is oriented at a finite angle (L) in relation to the centre axis.
3. Device according to Claim 1 or 2, characterized in that the first sensor coil (4.1) is arranged in the shaft (3).
4. Device according to any one of the preceding claims, characterized in that the second sensor coil (4.2) is arranged in an attachment (2.3) of the insertion head (2).
5. Device according to any one of the preceding claims, characterized in that the rod (4) bearing the two sensor coils (4.1, 4.2) extends through a lumen (2.3.1) of the device (1).

- 8 -

6. Device according to any one of the preceding claims, characterized in that the rod (4) is connected in an axially fixed manner to a holder (5) attachable to the attachment (2.3) of the insertion head (2).
7. Device according to Claim 6, characterized in that the attachment (2.3) of the insertion head (2) and the holder (5) comprise corresponding Luer adapter parts (6.1, 6.2) facing toward one another having Luer adapter (6), and attachment (2.3) and holder (5) are fixedly connectable to one another by the Luer adapter (6).
8. Device according to any one of the preceding claims, characterized in that a connecting wire extends from each sensor coil (4.1, 4.2) through the rod (4) up to its proximal end for connection to an analysis unit.

