

No. 758,972.

PATENTED MAY 3, 1904.

M. KAMMERER.
MACHINE FOR MOLDING PLASTIC MATERIAL.

APPLICATION FILED AUG. 18, 1902.

NO MODEL.

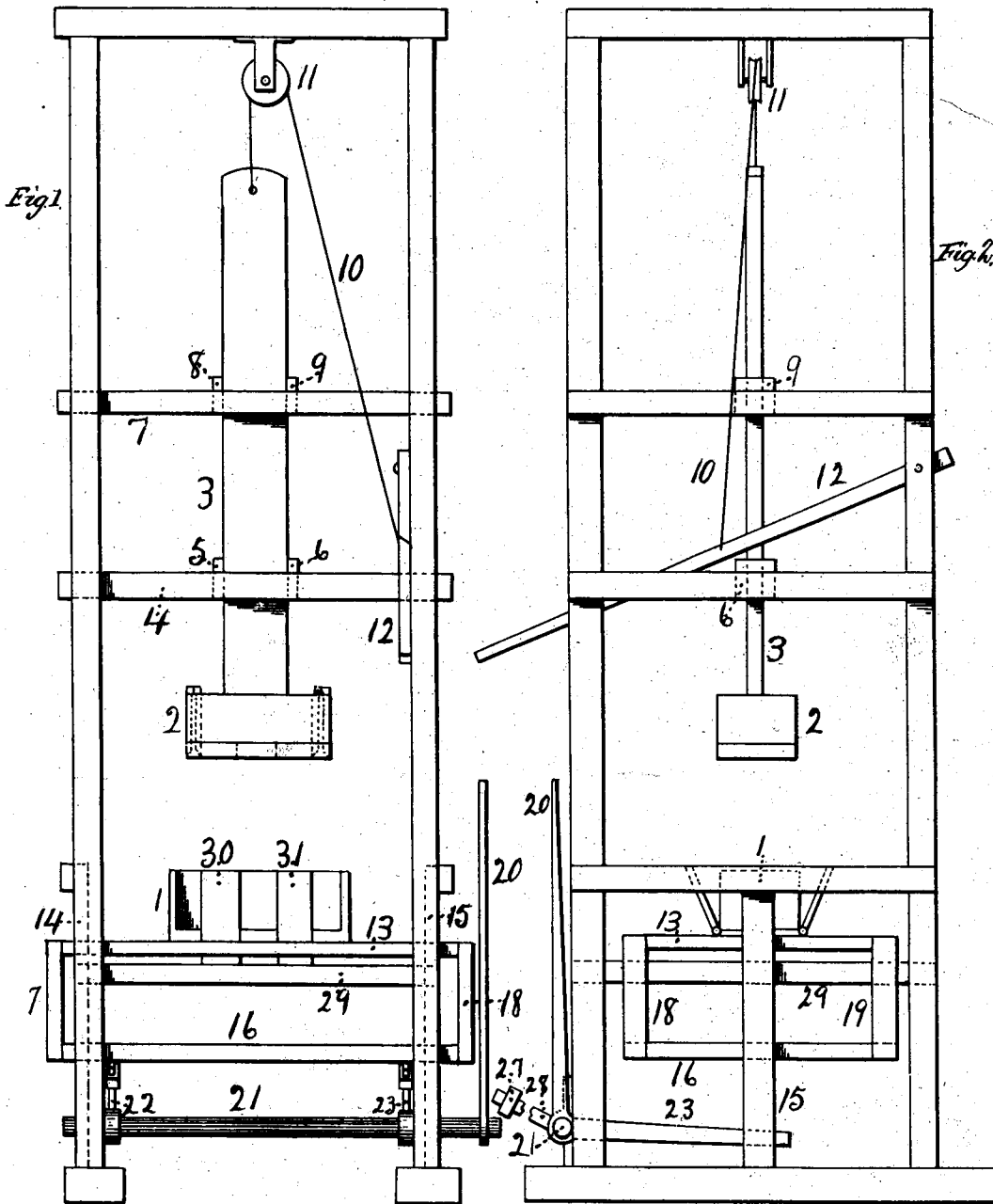

Witnesses:
W. J. McComb
Francis O'Malley

Fig. 4.
Inventor:
Fig. 5.
 32 Math Kammerer
 by O. F. Dimmick
 attorney

UNITED STATES PATENT OFFICE.

MATHIAS KAMMERER, OF FAIRBURY, ILLINOIS.

MACHINE FOR MOLDING PLASTIC MATERIAL.

SPECIFICATION forming part of Letters Patent No. 758,972, dated May 3, 1904.

Application filed August 18, 1902. Serial No. 120,010. (No model.)

To all whom it may concern:

Be it known that I, MATHIAS KAMMERER, a citizen of the United States, residing at Fairbury, in the county of Livingston and State of Illinois, have invented a new and useful Machine for Molding Plastic Material, of which the following is a specification.

My invention relates to improvements in that class of molding-machines in which a molding chamber or box is adapted to receive plastic material.

It relates more particularly to improvements in machines for molding concrete building-blocks.

The objects of my improvement are, first, to provide a simple and effective means for impacting the plastic material in such a molding-box, and, second, to provide means for producing concrete blocks or similar material more rapidly and with greater ease for the workmen than is possible with the machines commonly used for such purposes. I attain these objects by the mechanism shown in the following drawings.

Figure 1 is a front elevation of the entire machine; Fig. 2, a side elevation of the same, and Figs. 3, 4, and 5 are detailed views of parts of the machine more fully described hereinafter.

Similar numerals refer to similar parts throughout the several views.

The molding-box 1 is provided with hinged or removable sides. In Fig. 1 the front side of the box is removed, and in Fig. 2 one end is removed. A beater 2 is attached to the lower end of the vertically-reciprocating beater-rod 3 and is adapted to enter the box 1. The beater-rod 3 moves freely between two fixed parallel guide-bars, only one of which appears in the drawings at 4, Fig. 1. Blocks 5 and 6 are fixed between the two guide-bars and serve as lateral guides for the rod 3. A similar pair of guide-bars, one appearing at 7, Fig. 1, with interposed blocks 8 and 9, provide an upper passage, through which the rod 3 slides freely. The cord 10, passing over the pulley 11, is attached at one end to a hand-lever 12 and at the other to the rod 3, as shown. This construction permits an operator to impart vertical reciprocating

motion to the beater 2 by vertical movement of the lever 12.

A molding-table 13, to which the molding-box 1 is rigidly secured, has its ends notched or recessed to engage the fixed uprights 14 and 15. (Shown in dotted lines in Fig. 1.) The upright 15 appears in full lines in Fig. 2. A base-board 16, with notched ends, as described, is placed below the table 13 and rigidly connected to the table 13 by connecting-strips 17 and 18, Fig. 1, and 18 and 19, Fig. 2. By this construction the table 13 and the base-board 16 may move together in a vertical direction.

A vertical reciprocating motion is imparted to the table 13 and connected parts by the lever 20, attached to the rock-shaft 21, and jointed connections between the radial arms on the rock-shaft 21 and base-board 16. Fig. 3 is a plan view of the rock-shaft 21 with radial arms 22 and 23. Fig. 4 is a side view, on reduced scale, of one of the arms on the rock-shaft 21, in which 23 is the arm, 24 a portion of the base-board 16, 25 a lug rigidly attached to the board 16, and 26 is a link connected at its lower end by a jointed connection to the arm 23 and at its upper end to the lug 25.

To enable an operator to manipulate the lever 20 and parts connected therewith with greater ease, an adjustable counterweight 27 is adapted by means of a hole in the counterweight to slide upon an arm 28, rigidly attached to the rock-shaft 21, as shown in Figs. 2 and 3.

When perforated blocks are required, cores of the desired form are rigidly attached to the upper surface of a fixed core-stand placed below the table 13, as shown at 29, Figs. 1 and 2. In the drawings two cylindrical cores 30 and 31 are shown. When cores are used, holes in table 13 and in the bottom of box 1 are formed to register with the cores and permit them to project into the box 1. The beater 3 is provided with similar holes to permit it to descend to the bottom of the box when the cores are in place.

Fig. 5 is a plan view of a bottom plate 32, to be placed on the bottom of the box 1. It is also provided with holes to register with the cores in use and is removed from the machine with the finished block. The function

of the plate 32 is to support the finished block while removing it to a drying-room.

The cores 30 and 31 may be removed and replaced by others of different pattern. When
5 such a change is required, the table 13, the bottom of the box 1, and the beater 3 are also removed and replaced by similar parts, each having holes to register with the cores then in use. A similar change of bottom plates 32
10 is also required.

The operation of my machine is as follows: A bottom plate like that shown at 32, Fig. 5, is placed upon the bottom of box 1. The table 13, with attached parts, is then by moving
15 the lever 20 brought to its lowest position, and the material to be molded, while in a plastic condition, is placed in a molding-box 1, and the beater 2 is lowered to rest upon the contents of the box. By means of the lever 12
20 the beater may be made to lightly press the plastic material or forcibly beat the same until it is thoroughly impacted. The molding-box is then lifted by means of lever 20 until the molding-block and bottom plate 32 are
25 above the upper ends of the cores 30 and 31. The sides of the molding-box are then removed or opened, and the bottom plate, with the molded block upon it, is removed. The sides of the molding-box are then closed or
30 replaced, another bottom plate is put in the box, and the box lowered to its former position and the process repeated.

As shown in the drawings, the molding-box 1 is adapted to receive vertical reciprocating
35 motion; but this construction is not essential to my invention.

What I claim as my invention, and desire to secure by Letters Patent, is—

1. In a machine of the class specified, comprising a suitable frame, uprights 14 and 15
40 rigidly secured to said frame, a molding-table

13 having a recess in each end to receive said uprights, a base-board 16 rigidly secured to said molding-table and placed a suitable distance below the same, said base-board also
45 having a recess in each end to receive said uprights, a molding-box secured to said molding-table, a beater 2 and a guide-rod therefor; suitable guide-blocks for said rod, a pulley at the upper end of said frame, a lever pivotally
50 secured at a convenient point to said frame and a cord passing over said pulley and having one of its ends secured to said rod and the opposite end secured to said lever, whereby said beater may be manually controlled and
55 the force of the blow accurately regulated to any degree desired, all combined as and for the purpose set forth.

2. In a molding-machine of the class described, comprising a frame having a molding-table slidingly mounted thereon, a mold
60 secured to said table, a beater having a guiding-rod, brackets to retain said beater in alignment with said mold, means to manually operate said beater, a rock-shaft 21 pivotally
65 mounted upon said frame adjacent to the lower end thereof, a hand-lever 20 rigidly secured thereto, arms 22 and 23 secured to said shaft and at right angles to said hand-lever, lugs secured to a portion of said molding-table,
70 links interposed between said lugs and the free end of said arms, arms 28 also rigidly secured to said shaft and extending in the opposite direction from the arms 22 and 23, and counterweights movably mounted thereon, all
75 combined substantially as and for the purpose set forth.

MATH. KAMMERER.

Witnesses:

JOHN BURKHART,
JACOB GAHWILER.