



INTERNATIONAL APPLICATION PUBLISHED UNDER THE PATENT COOPERATION TREATY (PCT)

<p>(51) International Patent Classification⁶ : E03D 9/02</p>	<p>A1</p>	<p>(11) International Publication Number: WO 97/36065</p> <p>(43) International Publication Date: 2 October 1997 (02.10.97)</p>
<p>(21) International Application Number: PCT/US97/04417</p> <p>(22) International Filing Date: 20 March 1997 (20.03.97)</p> <p>(30) Priority Data: 9606275.7 26 March 1996 (26.03.96) GB</p> <p>(71) Applicant (for all designated States except US): S.C. JOHNSON & SON, INC. [US/US]; 1525 Howe Street, Racine, WI 53403 (US).</p> <p>(72) Inventors; and (75) Inventors/Applicants (for US only): THOMPSON, Guy, R. [GB/GB]; 17 Gleneagles Drive, Southwood, Farnborough, Hants GU14 0PH (GB). CAMPBELL, Stuart, J. [GB/GB]; 24 Isobel House, Staines Road West, Sunbury on Thames, Middlesex TW16 7BD (GB).</p> <p>(74) Agents: BOZEK, Laura, L. et al.; S.C Johnson & Son, Inc., Patent Section, 1525 Howe Street, Racine, WI 53403-2236 (US).</p>		<p>(81) Designated States: AU, BR, MX, NZ, US, European patent (AT, BE, CH, DE, DK, ES, FI, FR, GB, GR, IE, IT, LU, MC, NL, PT, SE).</p> <p>Published With international search report. Before the expiration of the time limit for amending the claims and to be republished in the event of the receipt of amendments.</p>
<p>(54) Title: DISPENSING DEVICE</p>		
<p>(57) Abstract</p>		
<p>A dispenser (1) for attachment to a toilet bowl rim to dispense liquid dissolved from a solid block (3) has provision for replacing an exhausted block without the need to remove the dispenser from the toilet bowl or otherwise manipulate the dispenser (1). A reload aperture (11) is provided in a position not obstructed by the clip (4) used to hold the dispenser (1) on the toilet bowl. The opening may be in the form of a narrow slot (11) with a resilient hinged cover (12) to prevent contact with the block (3) once inserted.</p>		

FOR THE PURPOSES OF INFORMATION ONLY

Codes used to identify States party to the PCT on the front pages of pamphlets publishing international applications under the PCT.

AL	Albania	ES	Spain	LS	Lesotho	SI	Slovenia
AM	Armenia	FI	Finland	LT	Lithuania	SK	Slovakia
AT	Austria	FR	France	LU	Luxembourg	SN	Senegal
AU	Australia	GA	Gabon	LV	Latvia	SZ	Swaziland
AZ	Azerbaijan	GB	United Kingdom	MC	Monaco	TD	Chad
BA	Bosnia and Herzegovina	GE	Georgia	MD	Republic of Moldova	TG	Togo
BB	Barbados	GH	Ghana	MG	Madagascar	TJ	Tajikistan
BE	Belgium	GN	Guinea	MK	The former Yugoslav Republic of Macedonia	TM	Turkmenistan
BF	Burkina Faso	GR	Greece			TR	Turkey
BG	Bulgaria	HU	Hungary	ML	Mali	TT	Trinidad and Tobago
BJ	Benin	IE	Ireland	MN	Mongolia	UA	Ukraine
BR	Brazil	IL	Israel	MR	Mauritania	UG	Uganda
BY	Belarus	IS	Iceland	MW	Malawi	US	United States of America
CA	Canada	IT	Italy	MX	Mexico	UZ	Uzbekistan
CF	Central African Republic	JP	Japan	NE	Niger	VN	Viet Nam
CG	Congo	KE	Kenya	NL	Netherlands	YU	Yugoslavia
CH	Switzerland	KG	Kyrgyzstan	NO	Norway	ZW	Zimbabwe
CI	Côte d'Ivoire	KP	Democratic People's Republic of Korea	NZ	New Zealand		
CM	Cameroon			PL	Poland		
CN	China	KR	Republic of Korea	PT	Portugal		
CU	Cuba	KZ	Kazakstan	RO	Romania		
CZ	Czech Republic	LC	Saint Lucia	RU	Russian Federation		
DE	Germany	LI	Liechtenstein	SD	Sudan		
DK	Denmark	LK	Sri Lanka	SE	Sweden		
EE	Estonia	LR	Liberia	SG	Singapore		

DISPENSING DEVICE

5

Technical Field

The present invention relates to a device for dispensing a product into the bowl of a water closet (also known as toilet or lavatory). In particular it relates to a device adapted to be hooked under the rim of a toilet bowl to interrupt the flow of flush water as the toilet is flushed and to dispense the product directly into the toilet bowl.

Background Art

15 Dispensing devices of the type with which the present invention is concerned are well-known. For example such a device is disclosed in US 4 777 670. In these devices the product which is dispensed is held in the device in the form of a solid block of water-soluble material which dissolves gradually in use. In general the block of product is introduced into a moulded container of plastics material, incorporating the necessary suspending means, at the time of manufacture of the device. US 4 777 670 discussed above mentions the possibility of introducing a fresh block of product into the dispenser. However, in order to do this it is necessary to remove the used device from the toilet rim and then to release a catch in order to hinge upwards an upper cover. Many of the dispensers on the market are capable of being hinged to open them once they have been removed from the toilet bowl. Nevertheless many dispensers are discarded after use although they are

25

capable of being re-used, leading to a waste of the plastics material used to produce the mouldings.

WO 93/16242 discloses a dispenser for attaching to the rim of a toilet bowl. It acknowledges the problem arising from disposal of dispensers, and proposes to overcome this by providing a dispenser which can be refilled while remaining attached to the rim. The dispenser is hinged open by pressing on a lug to release a catch which holds the dispenser closed. The dispenser can then be opened, a fresh block inserted, and the dispenser then closed again. However, it is still necessary to manipulate the dispenser itself.

It has now been found that, in order to provide a satisfactory re-usable rim-fastening toilet bowl dispenser, it is necessary and possible to provide for secure replacement of product blocks which have been used up without the need to manipulate the device itself. It has also found possible to produce such a dispenser which has a useful degree of protection of the product block, once inserted, against access by children.

Disclosure of Invention

According to the present invention a dispenser for using a flow of water during a toilet flush to dispense a dissolvable product from a solid block of said product into a toilet bowl comprises

- a) a holder for holding the solid block, said holder having a rearward side, which in use is adjacent to the toilet bowl, and a forward side facing the interior of the bowl in use,
- b) suspending means for attaching said holder to the rim of a toilet bowl,

wherein the holder has a reload opening extending across the centre of the holder, the size of the reload opening and its position relative to the suspending means being selected such that a replacement block may be inserted into the holder while it is positioned in the toilet bowl without manipulation of the dispenser.

5 Dispensers for attaching to the rim of toilet bowls are initially sold with a product block which has been loaded in the factory, usually by inserting into an open moulding which is then closed to give the loaded dispenser. The dispenser is then packaged, for example in a transparent blister pack, for sale. The packaged dispenser is displayed for sale together with replacement blocks for insertion in the
10 dispenser when the original block, inserted in the factory, has been used.

According to a further aspect of the present invention there is provided a package containing a dispenser for using a flow of water during a toilet flush to dispense a dissolvable product from a solid block of said product into a toilet bowl which
15 comprises

- a) a holder for holding the solid block, said holder having a rearward side, which in use is adjacent to the toilet bowl, and a forward side facing the interior of the bowl in use,
- b) suspending means for attaching said holder to the rim of a toilet bowl,
- 20 c) a factory-loaded product block within the holder,

wherein the holder has a reload opening extending across the centre of the holder, the size of the reload opening and its position relative to the suspending means being selected such that it is possible to insert a replacement block into the holder while the holder is positioned in the toilet bowl without manipulation of the
25 dispenser, said replacement block corresponding in size to the factory-loaded block within the holder.

The invention has been presented as an article, namely the dispenser. It is also a method of treating a flushable toilet bowl having a rim which comprises the steps of

- a) securing to the rim of the toilet bowl a dispenser according to the invention,
- 5 b) loading a product block into the dispenser attached to the rim without manipulating the dispenser,
- c) flushing the toilet bowl at intervals to dispense an aqueous solution of product dissolved from the block into the toilet bowl.

10 The dispenser may contain a product block when it is attached to the rim of the toilet bowl, so that the step of loading a product block mentioned above is a step of reloading the dispenser. Alternatively the dispenser may be attached to the rim in an empty (unloaded) state and the first loading of product block into the dispenser takes place when the dispenser is in place in the toilet bowl.

15 The relative positions of different parts of the dispenser are described as if the dispenser was in place in a toilet bowl, with the side towards the bowl as the rear, the dimension generally parallel to the toilet rim as the length, the dimension in the generally downward direction as the depth, and dimensions in the direction from
20 front to rear being described as width.

It will be appreciated that if the reload opening does not extend across the centre of the device it will not be possible to provide for reloading a block of the same or substantially the same size as any block installed at the time of initial manufacture.

25 The suspending means may be a clip attached to one or both ends of the holder so

as not to impede access to the reload opening. However a single clip at the end of the holder will need to ^{be} relatively large and rigid to maintain the holder in position against the turning forces generated by the off-centre suspension of the holder. The provision of a clip at each end will result in a device requiring more material for its construction. Because the toilet bowl rim is curved, providing clips at two points
5 may require the provision of a more complicated design of holder to match the curve of the bowl. It is therefore usual in dispensing devices for attachment to the rim of a toilet bowl to provide a single longitudinally central suspending means, as in US 4 777 670. When such a central suspending means is provided it is necessary to provide the reload opening forward of the point of connection of the suspending
10 means to the holder, i.e. further from the wall of the toilet bowl. Otherwise it will be necessary to manipulate the device, i.e. by handling the suspending means so as to remove it from the toilet bowl to gain access to any reload opening rearward of the point of connection of the suspending means.

15 It is highly desirable for the reload aperture to be such as to make it difficult or impossible for the product block to be removed from the holder after it has been inserted, to prevent the user coming into contact with a product block covered in possibly harmful solution. It is therefore preferred to use a slab shaped product block whose width in the forward -rearward direction is small relative to the length
20 and depth of the block, for example whose width is not more than 50% of the length of the block and to use a reload aperture in the form of a slot whose length and width are only sufficiently greater than the width and thickness of the block to allow the block to be inserted without difficulty into the holder. Thus it is preferred to use a reload opening whose width (i.e. its distance front to back) is not more
25 than 50% of the length of the reload opening, more preferably not more than 20%, most preferably not more than 15% of the length. In particular it is preferred for

the reload opening to be a slot extending longitudinally along the holder with the width of the slot not greater than 25 mm, more preferably not greater than 10 mm .

5 The holder may have an internal horizontal cross-sectional area which varies with depth. By internal horizontal cross-sectional area we mean the area of a horizontal plane bounded by the internal surface of the holder. Preferably the holder has a minimum internal horizontal cross-sectional area which ^{is} not less than the cross-sectional area of the loading opening, e.g., more preferably not less than 1.5 times the cross-sectional area of the loading aperture, for example not less than 2 times the cross-sectional area of the loading opening. This minimum cross-sectional area
10 may be at the bottom of the holder.

Preferably the maximum internal horizontal cross-sectional area is not more than 5 times the cross-sectional area of the loading opening, more preferably not more than 4 times the cross-sectional area of the loading opening. The maximum cross-sectional area may be in the upper part of the holder.
15

The reload opening will most preferably be positioned on the holder so that a replacement block which is inserted into the opening will fall into the holder and will be retained by gravity. The reload opening will thus generally be on the upper part of the holder. Some known designs of dispenser have suspension means which project forward from the connection with the holder before curving back to the rear to engage the toilet rim. In order to avoid any interference between the suspension means and the replacement block which would interfere with the insertion of the block it may be desirable to provide the reload opening on an upper surface of the holder which is inclined to the horizontal when the holder is in use so that the product block may be inserted from above but at an angle to the vertical which
20
25

keeps it clear from the suspending means.

Where the reload opening is positioned so that the block is inserted at an angle to the vertical it may be desirable to shape the holder so that the path through which the block travels when loaded into the holder has a decreasing angle to the vertical. This may be achieved by providing a holder with a front surface which is concave (viewed from the front).

It is desirable to provide additional protection to the user and, in particular, protection to children who may seek to obtain access to the product block in use. A baffle is preferably provided to restrict access by the fingers to the block once it has been loaded through the reload opening.

The baffle may be a displaceable baffle member which extends into the reload opening, which baffle is displaceable by the product block when the block is inserted in the reload opening, and preferably is biased to return to obstruct the reload opening when the product block is fully inserted into the holder.

The displaceable baffle member may extend across the reload opening so as to block it at the exterior of the holder. Alternatively it may extend into the interior of the holder provided that it obstructs access to the block when the block has been fully inserted.

A fixed baffle extending into the interior of the holder may be provided. The fixed baffle is sized and positioned so as to allow insertion of a replacement block but to obstruct removal of a loaded block after it has been inserted into the loading aperture. A fixed baffle is particularly useful where a large reload opening is

provided to receive large blocks. Thus it may be desirable to provide a reload aperture which allows a block to be inserted by movement from the centre of the toilet bowl in a substantially horizontal direction and which has a fixed baffle extending substantially horizontally from the lower edge of the reload opening such that a block may be slid over it into the interior of the dispenser but fingers
5 cannot bend round the baffle to obtain access to the block.

It may be desirable to provide both displaceable and fixed baffles.

10 The displaceable baffle is preferably a flexible baffle.

The flexible baffle may be at least one flap which is attached along an edge of the reload opening so as to move (preferably resiliently) inwards towards the interior of the dispenser as the block is inserted and which is (preferably resiliently) urged back to its original position when the block is fully inserted. The depth of the
15 holder within which the block is received is preferably greater than the depth of the block and the width of the flap to allow sufficient clearance for the flap to return.

Preferably a plurality of independently attached flaps is provided so that all the flaps must be independently moved simultaneously to gain access to the block.

20 This will be difficult for a small child.

Where the flexible baffle comprises a plurality of flaps then the flaps may be spaced along the reload opening with gaps separating the flaps.

25 Devices for attaching to toilet rims for dispensing products into toilet flush water are well-known, and the present invention may be applied to a variety of devices

with different ways of regulating the flow of dissolved product from the device,
e.g. using siphons.

5 One preferred form of the invention has at least one flush inlet opening at the
upper end to allow water to enter, and at least one flush discharge opening at the
rear side of the holder for the release of dissolved product into the flush,

10 Materials suitable for incorporation into products blocks for use in rim-fitting toilet
flush dispensers are well-known. It is preferred to use materials which enable
blocks of small size but high effectiveness to be used as this enables the size of the
reload opening to be minimized.

15 Dispensers are usually sold loaded with a product block and it is often convenient
to mould the dispenser as a single moulding having a hinge by which two parts of
the moulding can be hinged together to form the block holder and having a
retaining catch to hold the parts together when they are hinged towards each other.
The initial block is loaded into the dispenser when it is in an open position and the
two parts are hinged together to close it. In the known dispensers the retaining
catch is normally made sufficiently weak to allow it to be reopened by normal
finger pressure without the use of tools. This allows the holder to be reopened for
20 reloading. In a preferred form of the invention the holder is openable by rotation
about a hinge but is secured by a child-resistant retaining catch, i.e. a catch which
cannot easily be opened by finger pressure without the use of a tool or excessive
force.

25

Brief Description of Drawings

The invention will now be described with reference to the accompanying drawings

in which

Figure 1 is a diagrammatic perspective view of a dispenser according to the present invention;

Figure 2 is a plan view of the dispenser in its opened out state before insertion of the initial product block during the manufacturing process;

5 Figure 3 is a cross-section through the centre of the dispenser in its open position; and

Figure 4 is a perspective view, partially in cross-section, showing another form of dispenser according to the invention.

10 Best Mode of Carrying Out the Invention

Referring to the drawings a dispenser according to the invention is shown generally at (1). It is moulded in one piece from polypropylene. It comprises a holder (2) for receiving a block of product (3) for release into the flushing water during flushing of a toilet bowl. A clip (4) is attached to the upper surface of the holder (1) to enable it to be suspended from the rim of a toilet bowl. In use a rear portion (5) of the holder will be adjacent to the toilet bowl. This rear portion is provided with a plurality of flush inlets (6) extending round the top and rear face of the rear portion for admitting flush water into the holder (2) and with four longitudinally extending slots (7) which serve as flush discharge outlets to release solution, produced by the action of the flush water on the block, into the bowl. A pair of slots (7) is provided on either side of the centre of the holder.

The holder has a front portion (8) which in use faces into the centre of the toilet bowl. It is provided with an upper forwardly and downwardly inclined face (9) which is forward of the clip (4) and a lower rearwardly and downwardly inclined face (10). The upper face (9) is provided with a slot (11) which acts as a reload

opening for inserting a replacement product block (2) when the originally installed block has been exhausted. The slot is provided with a plurality of flaps (12) independently hinged at the forward edge of the slot.

5 The dispenser is produced as a one piece moulding, as shown in Figure 2, and the two parts are folded together after insertion of a product block during the manufacturing process.

10 The two parts (5) and (8) are held together by a catch comprising a barbed tongue (13) engaging with a recess (14) to provide a childproof catch which cannot readily be opened.

15 In use the dispenser is clipped to the rim of a toilet bowl so that the rearward portion (5) is held against the toilet bowl. As flushing takes place the initially installed block is exhausted. A replacement block may be installed without removing the dispenser from the toilet bowl by pressing the lower edge of the block against the flaps so as to depress them into the interior of the holder. The block may be provided with a wrapper or gripping device (not shown) to avoid contact between the fingers and the block. However the importance of avoiding contact between the fingers and the block may be reduced because the block will be dry prior to installation. Because the slot (11) is formed in a face angled away from the horizontal, the risk of the clip (4) interfering with introduction of the block is reduced. When the block is fully inserted the resilient hinged flaps formed in the polypropylene moulding will spring back to their original position. As each flap is independently hinged it will be necessary to bend all the flaps independently at the same time to obtain access to the interior of the holder to remove the block.

20

25 Furthermore the width of the slot is typically less than 10mm, which will make it

12

difficult to insert a finger down the slot to touch the block whose upper surface is below the slot by a distance greater than the width of the flaps.

Figure 4 shows an alternative form of dispenser, in which the reload opening is in the form of a relatively wide slot (11). The slot has a horizontal baffle (15)

5 extending into the interior of the holder from the lower edge of the slot (11), and

hinged flaps (12) moulded into the holder, hinged to the upper edge of the slot (11) and extending downwardly and forwardly to obstruct the space between the upper edge and the fixed baffle (15). Only two hinged flaps (12) are shown.

10 A replacement block may be inserted into the reload opening (11) by sliding it along the horizontal baffle, displacing the flexible baffle, and allowing the block to fall through the space between the fixed baffle and the rear wall of the holder.

15

20

25

Claims:

1. A dispenser for using a flow of water during a toilet flush to dispense a dissolvable product from a solid block of said product into a toilet bowl which dispenser comprises
- 5 a) a holder for holding the solid block, said holder having a rearward side, which in use is adjacent to the toilet bowl, and a forward side facing the interior of the bowl in use,
- b) suspending means for attaching said holder to the rim of a toilet bowl, wherein the holder has a reload opening extending across the centre of the holder,
- 10 the size of the reload opening and its position relative to the suspending means being selected such that a replacement block may be inserted into the holder while it is positioned in the toilet bowl without manipulation of the dispenser.
2. A dispenser according to claim 1 wherein the suspending means is a single
- 15 longitudinally central suspending means and the reload opening is forward of the suspending means.
3. A dispenser according to either of claims 1 or 2 wherein the reload opening is in the form of a slot with a width which is not more than 50% of the length of the
- 20 slot.
4. A dispenser according to claim 3 wherein the width of the slot is not greater than 10mm.
- 25 5. A dispenser according to any one of the preceding claims wherein the reload opening is in a surface on the upper part of the holder, which surface is inclined to

the horizontal.

6. A dispenser according to any one of the preceding claims wherein a displaceable baffle extends into the reload opening, said displaceable baffle being displaceable by the product block when the block is inserted in the reload opening.

5

7. A dispenser according to claim 6 wherein the displaceable baffle is biased to return to obstruct the reload opening when the product block is fully inserted in the holder.

10

8. A dispenser according to either one of claims 6 or 7 wherein the displaceable baffle comprises at least one flap which is attached along an edge of the reload opening so as to move resiliently downward as the block is inserted, and which is resiliently urged back to its original position when the block is fully inserted.

15

9. A dispenser according to claim 8 having a plurality of independently hinged flaps.

20

10. A dispenser according to any one of the preceding claims having a fixed baffle extending into the interior of the holder, said fixed baffle being sized and positioned so as to allow insertion of a replacement block but to obstruct removal of a block after it has been inserted into the loading aperture.

25

11. A dispenser according to any one of the preceding claims having a reload aperture which allows a block to be inserted by movement from the centre of of the toilet bowl in a substantially horizontal direction and which has a fixed baffle extending substantially horizontally from the lower edge of the reload opening

such that a block may be slid over it into the interior of the dispenser but fingers cannot bend round the baffle to obtain access to the block.

12. A package containing a dispenser for using a flow of water during a toilet flush to dispense a dissolvable product from a solid block of said product into a toilet bowl which comprises

5 a) a holder for holding the solid block, said holder having a rearward side, which in use is adjacent to the toilet bowl, and a forward side facing the interior of the bowl in use,

b) suspending means for attaching said holder to the rim of a toilet bowl,

10 c) a factory-loaded product block within the holder

wherein the holder has a reload opening extending across the centre of the holder, the size of the reload opening and its position relative to the suspending means being selected such that it is possible to insert a replacement block into the holder while the holder is positioned in the toilet bowl without manipulation of the dispenser, said replacement block corresponding in size to the factory-loaded block within the holder.

13. A method of treating a flushable toilet bowl having a rim which comprises the steps of

20 a) securing to the rim of the toilet bowl a dispenser according to any one of the preceding claims,

b) loading a product block into the dispenser attached to the rim without manipulating the dispenser,

25 c) flushing the toilet bowl at intervals to dispense an aqueous solution of product dissolved from the block into the toilet bowl.

Fig.4

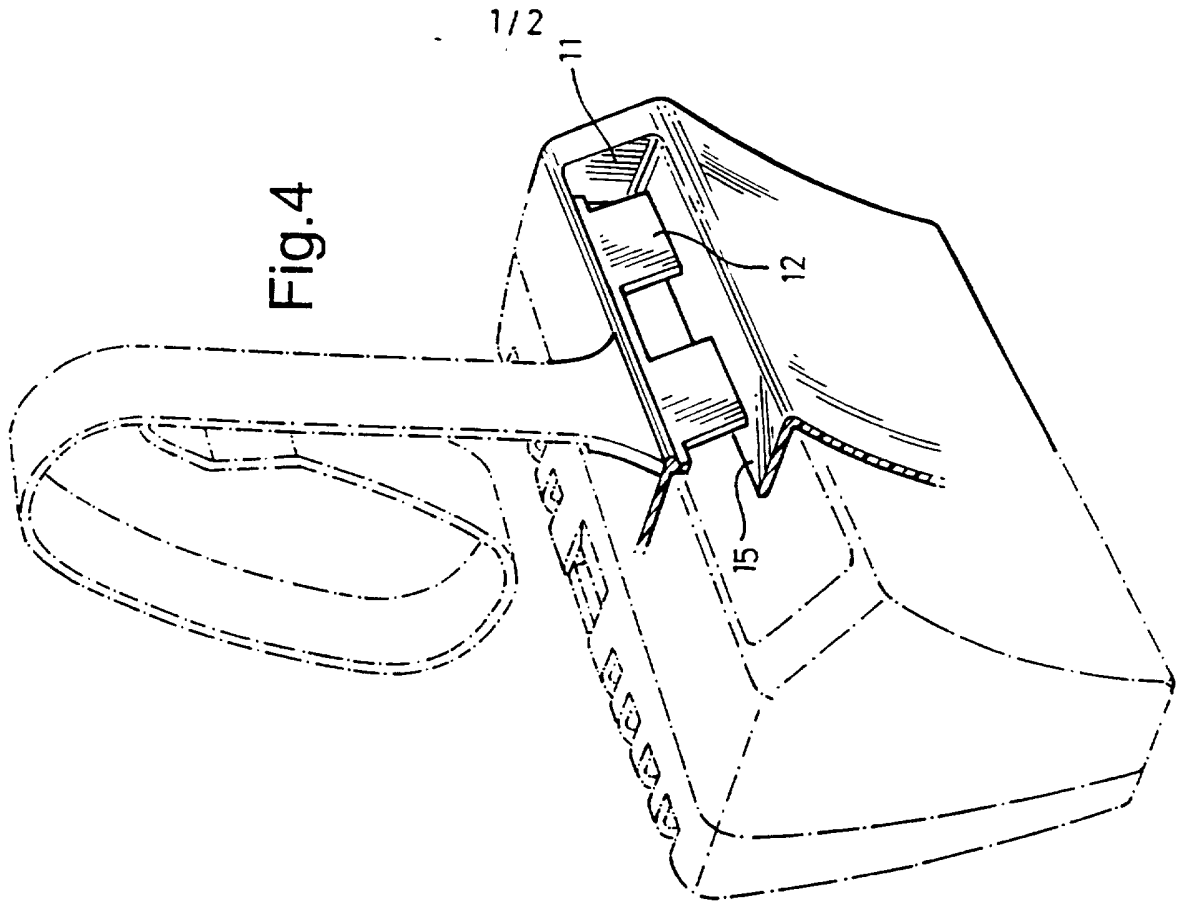
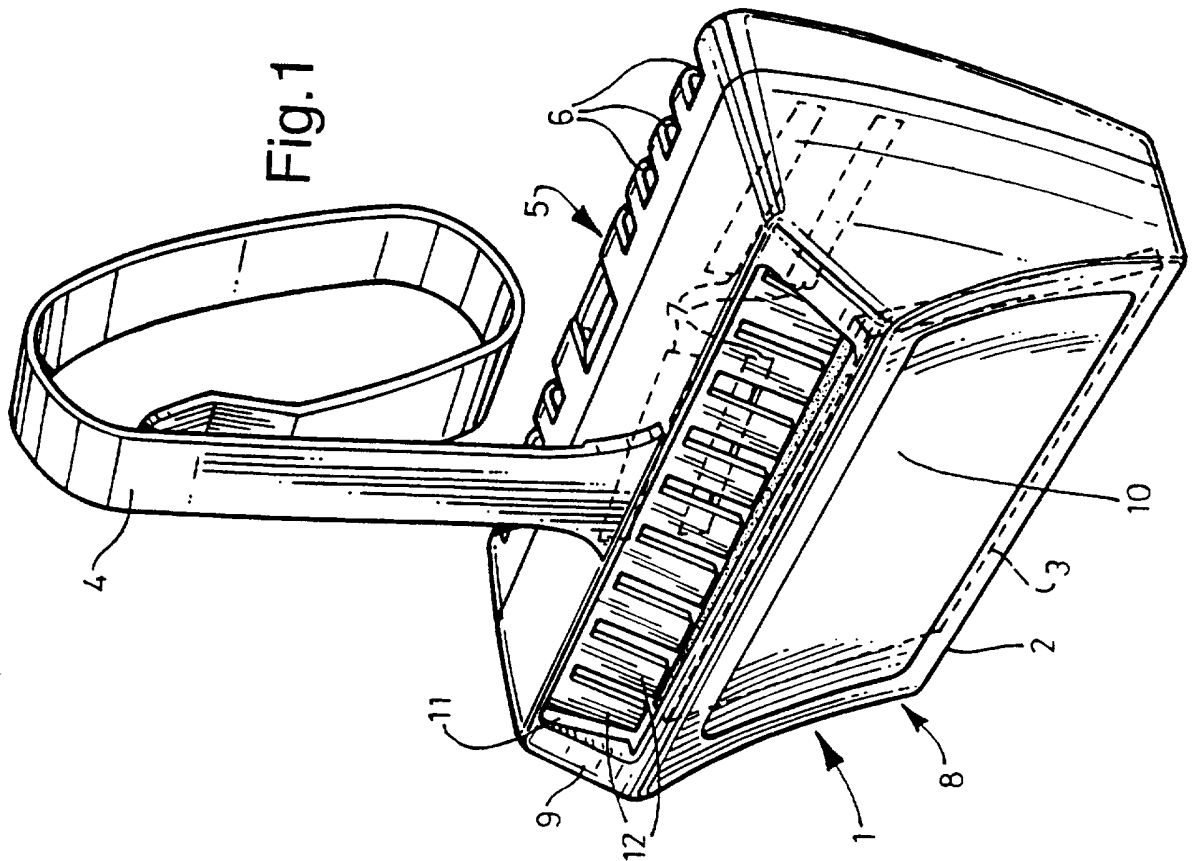

Fig.1



INTERNATIONAL SEARCH REPORT

Int. Application No
PCT/US 97/04417

A. CLASSIFICATION OF SUBJECT MATTER
IPC 6 E03D9/02

According to International Patent Classification (IPC) or to both national classification and IPC

B. FIELDS SEARCHED

Minimum documentation searched (classification system followed by classification symbols)
IPC 6 E03D

Documentation searched other than minimum documentation to the extent that such documents are included in the fields searched

Electronic data base consulted during the international search (name of data base and, where practical, search terms used)

C. DOCUMENTS CONSIDERED TO BE RELEVANT

Category *	Citation of document, with indication, where appropriate, of the relevant passages	Relevant to claim No.
X	US 2 034 619 A (HOFFMAN) 17 March 1936	1,2,12,13
Y	see page 1, right-hand column, line 8 - line 13; figures	5-8,10,11
A	---	3,4
X	DE 30 02 833 A (GLOBOL-WERK GMBH) 30 July 1981	1,6-10,12,13
A	see page 10, paragraph 1 - paragraph 2; figures	2-4,11
Y	---	
Y	EP 0 268 945 A (HENKEL KGAA) 1 June 1988	5-8,10,11
A	see the whole document	1-4
A	---	
A	EP 0 426 208 A (RE.LE.VI SPA) 8 May 1991 see the whole document	1-4,6-13

Further documents are listed in the continuation of box C. Patent family members are listed in annex.

* Special categories of cited documents :

<p>*A* document defining the general state of the art which is not considered to be of particular relevance</p> <p>*E* earlier document but published on or after the international filing date</p> <p>*L* document which may throw doubts on priority claim(s) or which is cited to establish the publication date of another citation or other special reason (as specified)</p> <p>*O* document referring to an oral disclosure, use, exhibition or other means</p> <p>*P* document published prior to the international filing date but later than the priority date claimed</p>	<p>*T* later document published after the international filing date or priority date and not in conflict with the application but cited to understand the principle or theory underlying the invention</p> <p>*X* document of particular relevance; the claimed invention cannot be considered novel or cannot be considered to involve an inventive step when the document is taken alone</p> <p>*Y* document of particular relevance; the claimed invention cannot be considered to involve an inventive step when the document is combined with one or more other such documents, such combination being obvious to a person skilled in the art.</p> <p>*&* document member of the same patent family</p>
--	--

Date of the actual completion of the international search 1 July 1997	Date of mailing of the international search report 25.07.97
--	--

Name and mailing address of the ISA European Patent Office, P.B. 5818 Patentlaan 2 NL - 2280 HV Rijswijk Tel. (+ 31-70) 340-2040, Tx. 31 651 epo nl, Fax (+ 31-70) 340-3016	Authorized officer Van Beurden, J
---	--

INTERNATIONAL SEARCH REPORT

Information on patent family members

International Application No

PCT/US 97/04417

Patent document cited in search report	Publication date	Patent family member(s)	Publication date
US 2034619 A	17-03-36	NONE	

DE 3002833 A	30-07-81	NONE	

EP 0268945 A	01-06-88	DE 3639686 A	26-05-88
		JP 63217027 A	09-09-88
		US 4813084 A	21-03-89

EP 0426208 A	08-05-91	AT 138143 T	15-06-96
		DE 69027000 D	20-06-96
		DE 69027000 T	02-10-96
		ES 2087885 T	01-08-96
