

(19) World Intellectual Property Organization  
International Bureau



(43) International Publication Date  
24 July 2003 (24.07.2003)

PCT

(10) International Publication Number  
WO 03/059779 A1

- (51) International Patent Classification<sup>7</sup>: **B65D 81/18**, F25D 5/02
- (21) International Application Number: PCT/IB02/05496
- (22) International Filing Date:  
18 December 2002 (18.12.2002)
- (25) Filing Language: English
- (26) Publication Language: English
- (30) Priority Data:  
02/00577 18 January 2002 (18.01.2002) FR
- (71) Applicant (for all designated States except US): **THERMAGEN** [FR/FR]; 1, avenue de la Terrasse, Bâtiment 5, F-91198 Gif-sur-Yvette (FR).
- (72) Inventors; and
- (75) Inventors/Applicants (for US only): **JEUCH, Pierre** [FR/FR]; 6, allée des Eglantines, F-91190 Saint-Aubin (FR). **KHAIRALLAH, Fadi** [FR/FR]; 11, rue du Pont Colbert, F-78000 Versailles (FR).
- (74) Agent: **BORIN, Lydie**; A.P.I. Conseil, Rue Marx Dormoy, F-64000 Pau (FR).
- (81) Designated States (national): AF, AG, AI., AM, AT, AU, AZ, BA, BB, BG, BR, BY, BZ, CA, CH, CN, CO, CR, CU, CZ, DE, DK, DM, DZ, EC, EE, ES, FI, GB, GD, GE, GH, GM, HR, HU, ID, IL, IN, IS, JP, KE, KG, KP, KR, KZ, LC, LK, LR, LS, LT, LU, LV, MA, MD, MG, MK, MN, MW, MX, MZ, NO, NZ, OM, PH, PL, PT, RO, RU, SC, SD, SE, SG, SK, SL, TJ, TM, TN, TR, TT, TZ, UA, UG, US, UZ, VC, VN, YU, ZA, ZM, ZW.

[Continued on next page]

(54) Title: INSULATION OF A SELF-COOLING BEVERAGE PACKAGE

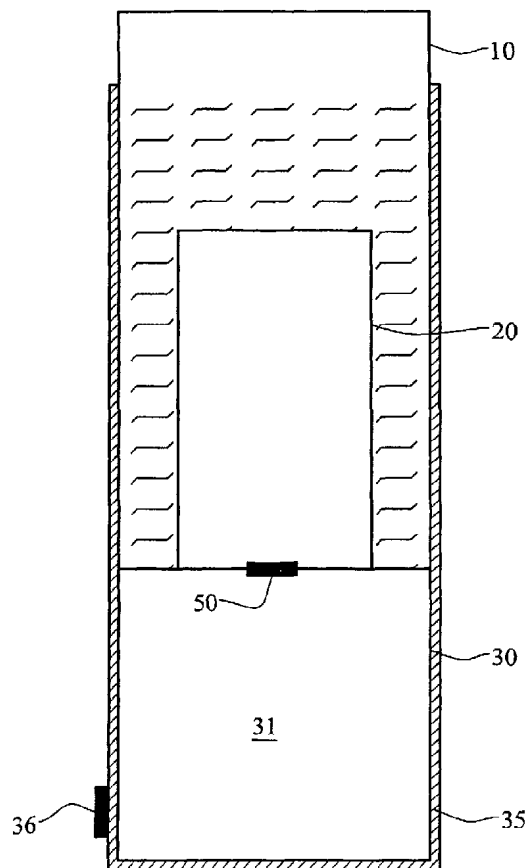

(57) Abstract: A self-cooling beverage package having a first cavity (10) containing a beverage for consumption, a second cavity (20) forming a heat exchanger and containing a refrigerant liquid and its vapour, a third cavity (30) containing means of pumping by adsorption of said vapour and means (50) of putting said second cavity into communication with said third cavity, characterised in that the third cavity (30) has an external thermal insulation layer (35).



WO 03/059779 A1



**(84) Designated States (regional):** ARIPO patent (GH, GM, KE, LS, MW, MZ, SD, SL, SZ, TZ, UG, ZM, ZW), Eurasian patent (AM, AZ, BY, KG, KZ, MD, RU, TJ, TM), European patent (AT, BE, BG, CH, CY, CZ, DE, DK, EE, ES, FI, FR, GB, GR, IE, IT, LU, MC, NL, PT, SE, SI, SK, TR), OAPI patent (BF, BJ, CF, CG, CI, CM, GA, GN, GQ, GW, ML, MR, NE, SN, TD, TG).

**Published:**

— *with international search report*

*For two-letter codes and other abbreviations, refer to the "Guidance Notes on Codes and Abbreviations" appearing at the beginning of each regular issue of the PCT Gazette.*

**INSULATION OF A SELF-COOLING BEVERAGE PACKAGE**

5           The present invention relates to a beverage package  
device allowing cooling of its contents by sorption  
cooling method. The principle of such a cooling method  
consists of evaporating a liquid under the effect of a  
partial vacuum maintained by pumping the vapours of said  
10 liquid. The invention is applicable most particularly to  
the cooling of a beverage contained in a can or bottle  
type closed package.

          The object of the present invention is thus to  
allow the consumption of a beverage at an ideal  
15 temperature anywhere and at any time.

          The implementation of the method of sorption  
cooling is known and has been the subject of much  
research in the prior art. Many devices have been  
proposed, associating a heat exchanger containing a  
20 refrigerant liquid to be evaporated with a cavity  
containing an adsorbent, in particular for applications  
to self-cooling beverage packages.

          One of the difficulties of implementing such a  
method of sorption cooling consists of managing the  
25 heat deposited in the adsorbent during the adsorption  
reaction. This is because, when the adsorbent,  
generally a desiccant such as zeolites, adsorbs the  
vapour of the refrigerant liquid, it heats up and  
therefore loses most of its adsorption capacity.  
30 Removing part of this heat deposited in the desiccant

improves significantly the cooling performances of the device.

Various solutions for limiting the rise in temperature of the adsorbent have already been proposed  
5 in the prior art.

A first known solution, described in the patent US 4 759 191, consists of removing the heat deposited in the adsorbent (a desiccant) by means of a heat sink consisting of a material in thermal contact with the  
10 desiccant, said material having either a solid-to-liquid phase change, or a high heat capacity, or an endothermic reaction. The patent US 4 949 549, from the same inventors, specifies the solution adopted, namely a material with a phase change such as sodium acetate,  
15 the solid-to-liquid phase change of which is situated at 58°C. This solution nevertheless requires the implementation of a particular container for the associated phase change material in the desiccant container, which complicates the method of manufacture  
20 of such self-cooling beverage packages because it requires efficient thermal coupling between the desiccant and the heat sink material.

An adaptation of this solution, described in the patent US 5 048 301, consists of thermally insulating  
25 the adsorbent with the heat sink in an evacuated chamber inside the beverage can. Nevertheless, this solution is complex to implement.

Patent application WO 01/10738 also describes a self cooling can using a sorption cooling method with a  
30 heat sink material. Since the phase change of the heat

sink material occurs around 60°C, the desiccant and the heat sink material are packaged in an insulating container to protect the consumer from the hot material.

5           Another known solution, described in the patent  
US 4 928 495, proposes storage of the heat deposited in  
the adsorbent (a desiccant) in water, the heat capacity  
of which is relatively high. An alternative, described  
10 in the same patent, consists of wetting the external  
surface of the desiccant container in order to remove  
the calories by evaporation of this water wetting the  
desiccant container. Nevertheless, the implementation  
of such a device is complex and protection against  
15 burns is no longer provided once the water wetting the  
external surface of the container has totally  
evaporated.

          Another solution, described in the patent  
application FR 2 811 412, consists of disposing thermal  
insulation at the periphery of a block of desiccant,  
20 inside the container containing said desiccant. This  
insulation is constituted by zeolites impregnated with  
resin in order to obstruct their porosity and prevent  
them adsorbing the vapours of the refrigerant liquid.  
By preventing the zeolites fulfilling their adsorption  
25 function, their heating up is prevented.

          The objective of the present invention is to  
propose an alternative solution to managing the heat  
deposited in the adsorbent during implementation of the  
sorption cooling method as described previously.

The simplest solution would be to let the adsorbent heats up to its equilibrium temperature and to provide enough adsorbent to achieve the proper cooling performance. The adsorbent for pumping the refrigerant liquid vapour advantageously consists of a dessicant such as a zeolite 13X for example. During the adsorption of water vapour by such a zeolite, the adsorbent can reach 200°C for an adsorption capacity of around 5% by mass of adsorbed water with respect to the mass of the desiccant. Thus, around 200g of zeolite are sufficient to adsorb 10g of water, the evaporation of which makes it possible to cool 330 ml of beverage by 15°C. It is therefore not essential to remove the heat deposited in the desiccant since the adsorption capacity limit is not reached.

With such a solution, the major difficulty is to provide the proper insulation for the heated adsorbent (about 200°C for zeolites). Two problems must be considered:

- avoid heating of the cooled beverage by heat flowing back from the adsorbent to the evaporator and beverage can;
- avoid excessive external temperature of the adsorbent container for consumer safety and comfort.

To this end, the present invention proposes an insulation layer design disposed around the adsorbent container which compels these two problems.

More particularly, the invention relates to a self-cooling beverage package device having a first

cavity containing a beverage for consumption, a second cavity forming a heat exchanger and containing a refrigerant liquid and its vapour, a third cavity containing adsorbent for pumping of said vapour and  
5 means of putting said second cavity into communication with said third cavity for operation of the device, characterised in that the third cavity has an external thermal insulation layer designed such that the heat flow from the adsorbent through the outside wall of the  
10 third cavity is larger or equal to the heat flow from the adsorbent to the second and first cavities during operation of the device.

According to one embodiment, the temperature of the external surface of the insulating layer rises to  
15 more than 70°C during operation of the device.

According to one characteristic, the thermal insulation layer has a thermal conductivity less than or equal to 500 W.m<sup>-2</sup>.K<sup>-1</sup>, and preferentially between 20 and 60 W.m<sup>-2</sup>.K<sup>-1</sup>.

20 According to another embodiment, the thermal insulation layer includes a material melting at a temperature between 40°C and 80°C. Possibly, the thermal insulation layer consists of at least two layers, one of them including the melting material.

25 According to embodiment, the thermal insulation layer surrounds the third cavity consisting of a metal container or the thermal insulation layer is constituted by the walls of a container forming the third cavity.

According to one embodiment, the thermal insulation layer extends around the first cavity.

According to one embodiment, the thermal insulation layer has a thermochromic label.

5

The features and advantages of the present invention will emerge in the course of the following description given by way of an illustrative and non-limitation example, and produced with reference to the accompanying figures in which:

10

- figure 1 is depicting a self-cooling beverage package according to the invention,
- figure 2 is depicting the insulation layer according to one embodiment of the invention,
- 15 - figure 3 is depicting the insulation layer according to another embodiment of the invention.

15

Referring to figure 1, the self-cooling beverage package according to the invention has a first cavity 10 containing a beverage for consumption, a second cavity 20 forming a heat exchanger and containing a refrigerant liquid, such as water, and its vapour and a third cavity 30 containing dessicant 31 for pumping by adsorption of said vapour. The second cavity 20 is also referred to as the evaporator and the third cavity 30 is also referred to as the desiccant container. Means 25 50 of putting said second cavity 20 into communication with said third cavity 30 are also provided for operation of the sorption cooling method.

30

The third cavity 30 consists of a container guaranteeing good vacuum sealing necessary for correct operation of the pumping means. Generally, this container is metallic. The risk of burning therefrom is all the higher. Thus, according to the invention, the third cavity 30 has a thermal insulation layer 35.

According to the present invention, the first previously identified problem (avoid heating of the cooled beverage by heat flowing back from the adsorbent container to the evaporator) is solved by an active heat shield concept which mainly works as follow:

As heat leaks out of the adsorbent 31, it cools down and consequently is capable of adsorbing more refrigerant vapour, resulting in additional cooling in the evaporator 20. In case of zeolites used as adsorbent, this additional cooling is about or above 50% of the heat leakage out of the adsorbent. The insulation layer 35 surrounding the dessicant container 30 is designed such that the heat flow from the adsorbent through the outside wall of the third cavity is at least as large as the heat flow towards the evaporator and the beverage can (respectively second 20 and first 10 cavities). With such insulation, the net effect is additional cooling of the beverage and not heating by dessicant heat.

Moreover, the second previously identified problem (avoid excessive external temperature of the adsorbent container for customer safety and comfort) is also solved by the insulation layer according to the invention.

According to one preferred solution, the thermal insulation layer 35 is provided with a conductivity adjusted to achieve an outer surface of said insulation layer to reach 70°C and up to 90°C during the sorption cooling process. This relatively high external surface temperature allows extracting about 0.1 W.cm<sup>-2</sup> through natural convection. However, this external surface temperature falls down to about 40-45°C on contact with fingers. This temperature drop on contact with a consumer fingers is due to the higher heat extraction by fingers as compared to the natural air convection (about three times more) combined with the high thermal gradient across the insulation layer which ranges from 20°C to 50°C.

This natural convection increases the absorption capacity of the desiccant and advantageously contributes towards prolonging the beverage cooling process. The heat power extracted, of the order of a few watts, is not a determining factor for the initial cooling of the beverage which is typically 15°C in 3 minutes, but it provides additional cooling over a much longer period, typically 2°C in 30 minutes, in order to keep the beverage cool during its consumption.

The thermal conductivity of the insulation layer that achieves these conditions is less than 100 W.m<sup>-2</sup>.K<sup>-1</sup> and preferably ranges from 20 to 60 W.m<sup>-2</sup>.K<sup>-1</sup>.

The temperature distribution (from inside the desiccant material 31, at the adsorbent container wall 30, to outside the external insulation 35) can also be influenced by the heat coupling between the desiccant

31 and the container wall 30 by providing an additional insulation inside the container.

Such internal insulation can be achieved by a method described in previously cited patent application  
5 FR 2 811 412, or by an adequate geometrical structuring of the desiccant 31 close to the wall of the container 30, such as ripples 39 as illustrated figure 2.

In this embodiment, the desiccant container wall  
10 30 equilibrium temperature is lowered and the required conductivity of the external insulation layer 35 must be higher to achieve the needed heat flow to the outside atmosphere. In this configuration, the conductivity of the external insulation layer 35 ranges from 100 to 500  $W.m^{-2}.K^{-1}$ . Since the desiccant container  
15 walls temperature is lowered, the heat flow towards the beverage can and the evaporator (first 10 and second 20 cavities) is reduced.

According to an alternative solution, an illustration of which is given figure 3, the insulation  
20 layer 35 includes a material melting at a temperature between 40°C and 80°C. This phase change material provides an active heat shield between the desiccant container 30 and the outside atmosphere such that the energy transmitted to the outside atmosphere is less  
25 than the energy flowing out of the desiccant container. The difference of energy corresponds essentially to the latent heat of the melting material. According to this embodiment, the insulation layer 35 consists of at least two layers 36, 37, one of them 36 including the  
30 melting material. A typical material that can be

incorporated in the insulation layer 36 is Sodium Acetate trihydrate melting at 58°C. An additional layer 37 of insulation without melting material is required to act as an thermal protection. This additional layer 5 37 has a thermal conductivity less than 100 W.m<sup>-2</sup>.K<sup>-1</sup>, typically 50. The phase change material can be incorporated in voids of the insulation layer 36.

The thermal insulation layer 35 is surrounding the metallic third cavity 30 and can be constituted by 10 a layer of cardboard and/or a number of layers of superposed paper and/or a plastic. It can be glued on the external surface of the third cavity 30 or be held by a heat-shrink plastic tube. It typically has a thickness between 0.5 and 1.5 mm in the first described 15 embodiment and can reach 3 to 5 or even 10 mm in the embodiment including melting material. The thermal insulation layer is advantageously put in place after the filling of the beverage, in particular in the case of pasteurised beverages where it is put in place after 20 pasteurisation.

The heat leakage through the can wall of the beverage can (first cavity 10) produces a thermal gradient along the adsorbent container wall 30. To optimise the heat leakage to the outside atmosphere while keeping 25 adequate protection for the consumer, the insulation layer 35 thickness can be reduced as it gets closer to the boundary between the beverage can 10 and the adsorbent container 30.

According to one particular embodiment, the thermal 30 insulation layer 35 can extend from the third cavity 30

containing the desiccant to the first cavity 10 containing the beverage for consumption. It can thus contribute towards keeping the beverage cool during its consumption.

According to one embodiment, the thermal insulation layer 35 has a thermochromic label 36, for example by printing of thermochromic ink directly on said insulating layer. This printing can be implemented opposite the desiccant container 30, for example on the hottest part of the self-cooling package. The appearance of the thermochromic ink at a given temperature threshold, for example at 60°C, can constitute an indicator of correct operation of the self-cooling device.

It can also be envisaged disposing the thermochromic label opposite the cavity 10 containing the beverage for consumption and which will be activated below a certain threshold, for example 10°C, in order to constitute an indicator for ideal consumption of the beverage.

One possible alternative consists of implementing the thermal insulation layer 35 directly by the walls of a container forming the third cavity 30.

The present invention provides self-cooling beverage packages with an effective physiological protection against the risks of burning due to the rise in temperature of the adsorbent. In order to achieve an equivalent protection situated inside the metal adsorbent container, thermal insulation would have to

have a thermal resistance five times greater, requiring more volume in the device and more material.

5 The thermal insulation layer according to the invention allows the use of an efficient adsorbent such as a zeolite without requiring recourse to heat sink which considerably complicate the manufacture of the device.

10 Moreover, the thermal insulation layer according to the invention makes it possible to naturally continue the cooling process and thus provides an addition to the initial rapid cooling in order to keep the beverage cool during its consumption.

**CLAIMS**

1. A self-cooling beverage package device having a first cavity (10) containing a beverage for consumption, a second cavity (20) forming a heat exchanger and containing a refrigerant liquid and its vapour, a third cavity (30) containing adsorbent (31) for pumping of said vapour and means (50) of putting said second cavity into communication with said third cavity for operation of the device, characterised in that the third cavity (30) has an external thermal insulation layer (35) designed such that the heat flow from the adsorbent through the outside wall of the third cavity (30) is larger or equal to the heat flow from the adsorbent to the second (20) and first (10) cavities during operation of the device.

2. A self-cooling beverage package according to Claim 1, characterised in that the temperature of the external surface of the insulation layer (35) rises to more than 70°C during operation of the device.

3. A self-cooling beverage package according to one of Claims 1 to 2, characterised in that the thermal insulation layer (35) has a thermal conductance less than or equal to 500 W.m<sup>-2</sup>.K<sup>-1</sup>.

4. A self-cooling beverage package according to Claim 3, characterised in that the thermal conductance of the insulating layer is between 20 and 60 W.m<sup>-2</sup>.K<sup>-1</sup>.

5. A self-cooling beverage package according to one of the preceding claims, characterised in that the

thermal insulation layer (35) has a thickness between 0.5 and 1.5 mm.

6. A self-cooling beverage package according to one of the preceding claims, characterised in that the thermal insulation layer (35) has a variable thickness.

7. A self-cooling beverage package according to Claim 1, characterised in that the thermal insulation layer (35) includes a material melting at a temperature between 40°C and 80°C.

8. A self-cooling beverage package according to Claim 7, characterised in that the thermal insulation layer consists of at least two layers, one of them including the melting material.

9. A self-cooling beverage package according to one of the claims 7 to 8, characterised in that the thermal insulation layer (35) has a thickness between 3 and 10 mm.

10. A self-cooling beverage package according to one of Claims 1 to 9, characterised in that the thermal insulation layer (35) surrounds the third cavity (30) consisting of a metal container.

11. A self-cooling beverage package according to one of Claims 1 to 9, characterised in that the thermal insulation layer (35) is constituted by the walls of a container forming the third cavity (30).

12. A self-cooling beverage package according to one of Claims 1 to 10, characterised in that the thermal insulation layer (35) extends around the first cavity (10).

13. A self-cooling beverage package according to one of the preceding claims, characterised in that the thermal insulation layer (35) has a thermochromic label (36).

5           14. A self-cooling beverage package according to Claim 13, characterised in that the thermochromic label (36) is disposed opposite the third cavity (30).

          15. A self-cooling beverage package according to Claim 13, characterised in that the thermochromic label  
10 (36) is disposed opposite the first cavity (10).

          16. A self-cooling beverage package according to one of the preceding claims, characterised in that the thermal insulation layer (35) consists of cardboard and/or paper and/or plastic.

1/2

Fig 1

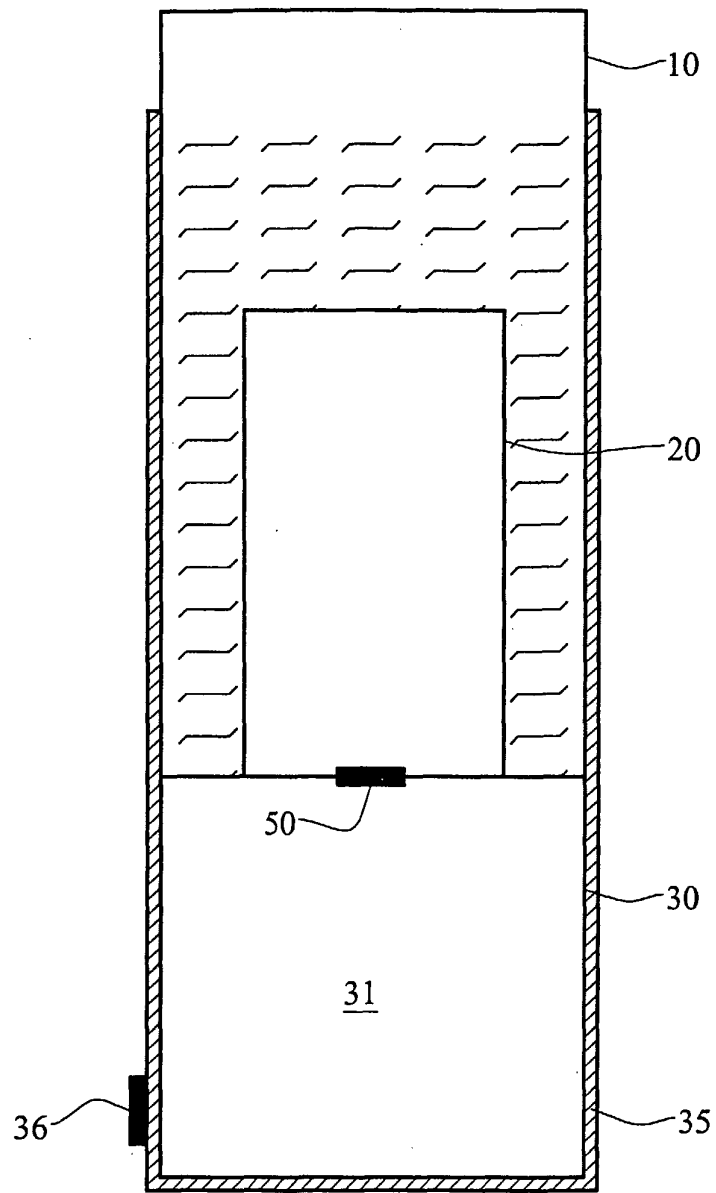

2/2

Fig 2

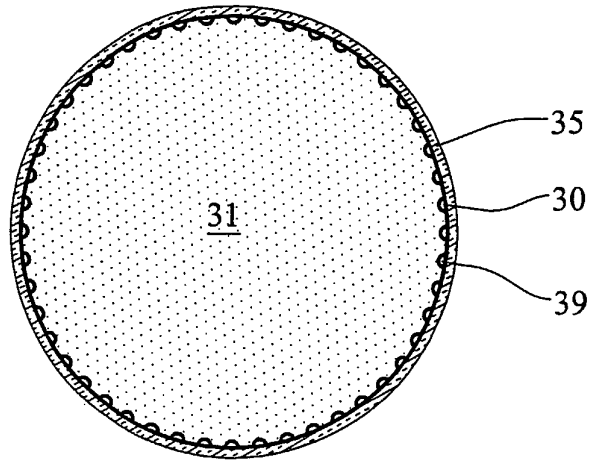

Fig 3

